

Network Control Program  
System Support Programs  
Emulation Program



# Resource Definition Guide



Network Control Program  
System Support Programs  
Emulation Program



# Resource Definition Guide

**Note**

Before using this information and the product it supports, be sure to read the general information under "Notices" on page xxiii.

**Ninth Edition (September 1999)**

This is a major revision of, and obsoletes, SC31-6223-07.

This edition applies to:

Advanced Communications Function for Network Control Program Version 7 Release 8 (program number 5648-063)

Advanced Communications Function/System Support Programs (ACF/SSP) Version 4 Release 8 for OS/390 and MVS (program number 5655-041)

Advanced Communications Function/System Support Programs (ACF/SSP) Version 4 Release 8 for VM (program number 5654-009)

Advanced Communications Function/System Support Programs (ACF/SSP) Version 4 Release 8 for VSE (program number 5686-064)

Emulation Program for IBM Communication Controllers Release 14 (program number 5735-XXB)

and to all subsequent releases and modifications until otherwise indicated in new editions or technical newsletters. See "What Is New in This Book" on page xxxii for the changes made to this manual. Technical changes or additions to the text and illustrations are indicated by a vertical line to the left of the change. Make sure you are using the correct edition for the level of the product.

Order publications through your IBM representative or the IBM branch office serving your locality. Publications are not stocked at the address given below.

IBM welcomes your comments. A form for readers' comments appears at the back of this publication. If the form has been removed, address your comments to:

Design & Information Development  
Department CGF/Bldg 656  
International Business Machines Corporation  
PO Box 12195  
RESEARCH TRIANGLE PARK, NC 27709-9990

When you send information to IBM, you grant IBM a nonexclusive right to use or distribute the information in any way it believes appropriate without incurring any obligation to you.

© Copyright International Business Machines Corporation 1988, 1999. All rights reserved.

US Government Users Restricted Rights – Use, duplication or disclosure restricted by GSA ADP Schedule Contract with IBM Corp.

---

# Contents

<b>Notices</b> . . . . .	xxiii
Notice to Users of Online Versions of This Book . . . . .	xxiv
Trademarks . . . . .	xxv
<b>About This Book</b> . . . . .	xxvii
Who Should Use This Book . . . . .	xxvii
How to Use This Book . . . . .	xxvii
Terms Used in This Book . . . . .	xxviii
Symbols Used in This Book . . . . .	xxxi
What Is New in This Book . . . . .	xxxii
Logical Line Pool Sharing for TIC3 Connections . . . . .	xxxii
Using 3746 Model 900 TIC3 Connection Balancing . . . . .	xxxii
Using Enhanced Control of the Dynamic Working Window for 3745 Token Ring . . . . .	xxxii
Specifying a Minimum Working-Window Value for 3745 Frame Relay . . . . .	xxxii
Using 3746 Model 900 Frame-Relay BAN Connection Balancing . . . . .	xxxii
Using Enhanced Control of Adaptive Session Pacing . . . . .	xxxii
Detecting a Hung Transmission Group (TG) . . . . .	xxxii
Specifying LRC8 Error Checking . . . . .	xxxii
Ignoring Data from an Undefined 3270 BSC Device . . . . .	xxxiii
Taking over an EP Line from Another Host . . . . .	xxxiii
Setting the V.25 Dial Timer . . . . .	xxxiii
Defining up to 32 ESCON Stations . . . . .	xxxiii
Generating a Minimum-Size Remote Load Module . . . . .	xxxiii
Where to Find More Information . . . . .	xxxiii
Information for NCP Tasks . . . . .	xxxiii

---

## Part 1. Producing an NCP

<b>Chapter 1. Defining Your NCP Configuration</b> . . . . .	1-1
What Kind of Network Are You Defining? . . . . .	1-1
Special Considerations for Using This Book . . . . .	1-3
Line Protocols . . . . .	1-3
Coding Conventions . . . . .	1-3
How You Define Resources to NCP . . . . .	1-4
Generation Process Control Definition Statement . . . . .	1-5
System Definition Statements . . . . .	1-5
Configuration Definition Statements . . . . .	1-5
Network Configuration Definition Statements . . . . .	1-6
NCP Router Definition Statements . . . . .	1-6
SNI Nonnative Network Definition Statements . . . . .	1-7
Block Handler Definition Statements . . . . .	1-7
Generation Delimiter Definition Statement . . . . .	1-7
Coding Lower Level Keywords on Higher Level Definition Statements . . . . .	1-7
Definition Statement Usage and Sequence for NCP Generation . . . . .	1-8
OPTIONS . . . . .	1-8
PCCU . . . . .	1-9
BUILD . . . . .	1-9
SYSCNTRL . . . . .	1-9

NCPNAU	1-9
GWNAU	1-10
HOST	1-10
IDLIST	1-11
LUPOOL	1-11
LUDRPOOL	1-11
PUDRPOOL	1-12
PATH	1-12
SDLCST	1-12
DIALSET	1-13
MTALCST	1-14
MTALIST	1-14
MTAPOLL	1-14
MTATABL	1-14
SWMMT	1-15
GROUP	1-15
LINE	1-16
DLCI	1-17
SERVICE	1-17
CLUSTER	1-18
TERMINAL	1-18
COMP	1-19
PU	1-20
IPHOST	1-21
LU	1-21
FRSESET	1-21
ENDAUTO	1-22
IPOWNER	1-22
IPLOCAL	1-22
IPROUTE	1-22
NETWORK	1-22
GWNAU	1-23
PATH	1-23
STARTBH	1-24
EDIT	1-24
DATETIME	1-24
UBHR	1-24
REMOVCTL	1-25
ENDBH	1-25
BHSET	1-25
GENEND	1-25
Definition Statements for Dynamic Reconfiguration	1-25
ADD	1-25
DELETE	1-26
<b>Chapter 2. Generating an NCP Load Module</b>	<b>2-1</b>
NDF-Generated Definition File	2-1
Reusable NEWDEFN File	2-3
FASTRUN Keyword	2-5
Defining the NCP Environment	2-5
Dynamically Created Control Blocks	2-10
Automatic Line Generation	2-12
Autocopy Function	2-12
Autoline Function	2-16

Migration Aid Function . . . . .	2-18
<b>Chapter 3. Defining Your Communication Controller . . . . .</b>	<b>3-1</b>
Defining an IBM 3745 Communication Controller . . . . .	3-1
Fallback and Switchback . . . . .	3-2
Fallback for NCP . . . . .	3-3
Fallback for EP (PEP only) . . . . .	3-5
Switchback . . . . .	3-5
Fallback and Switchback for IBM Special Products or User-Written Code . . . . .	3-6
3746 Model 900 Connectivity Subsystem . . . . .	3-6
Shared 3746 Model 900 Resources between Two NCPs . . . . .	3-7
Shared 3746 Model 900 Resources between an NCP and 3746 Model 900 . . . . .	3-7
Fallback and Switchback for 3746 Model 900 Resources . . . . .	3-8
Usage Tiers . . . . .	3-9
Usage Tiers for the IBM 3745 Communication Controller . . . . .	3-10
Usage Tiers for the 3746 Model 900 . . . . .	3-11

---

## Part 2. Defining NCP Resources

<b>Chapter 4. Channel Links and Access Methods . . . . .</b>	<b>4-1</b>
Defining System/370 I/O Channel Links . . . . .	4-1
Subarea Channel Links . . . . .	4-2
Peripheral Channel Links . . . . .	4-4
Migrating to a Type 7 Channel Adapter . . . . .	4-7
Loading and Dumping a Channel-Attached NCP . . . . .	4-7
Sample System/370 Channel Link Configuration and Definition . . . . .	4-8
Defining ESCON Links . . . . .	4-9
ESCON Generation Assistant . . . . .	4-12
ESCON Physical Lines . . . . .	4-13
ESCON Logical Lines . . . . .	4-14
Migrating a System/370 Channel Link to an ESCON Logical Line . . . . .	4-18
Using MOSS Extended to Configure ESCON Links . . . . .	4-22
Defining Subarea Addressing Limits . . . . .	4-26
Maximum Number of Concurrent Sessions and Routes . . . . .	4-27
Dynamic Control Facilities . . . . .	4-28
Defining NCP to VTAM . . . . .	4-29
<b>Chapter 5. NCP and Link-Attached Devices . . . . .</b>	<b>5-1</b>
Nonswitched Telecommunication Links . . . . .	5-1
Switched Links . . . . .	5-4
V.25 Bis . . . . .	5-7
Limited Resource Sessions . . . . .	5-10
Shared Port Identification . . . . .	5-11
SSCP Monitor Mode Function . . . . .	5-12
SMMF for Nonswitched SDLC Subarea Links . . . . .	5-12
SMMF for Switched SDLC Subarea Links . . . . .	5-13
SMMF for Nonswitched SDLC Peripheral Devices . . . . .	5-15
SMMF for Subarea Channel Links . . . . .	5-16
SMMF for ESCON Links . . . . .	5-17
Spare and Redefinable SDLC Lines . . . . .	5-19
Converting Existing SDLC Resources to 3746 Model 900 SDLC Resources . . . . .	5-21
Modems . . . . .	5-22
Channelized Modems . . . . .	5-23

Switched Network Backup	5-25
Devices Attached to NCP	5-26
BSC or Start-Stop Devices on Nonswitched Links	5-26
BSC or TWX Devices Attached to Switched Links	5-30
BSC Devices and VTAM	5-33
SDLC Devices on Nonswitched Links	5-33
SDLC Devices on Switched Links	5-34
SDLC Devices and VTAM	5-36
Maximum Number of Sessions to Maintain	5-37
Polling and Addressing	5-37
IBM 3174 Group Poll	5-42
Data Characteristics	5-43
End of Transmission	5-45
Delay between Successive Transmissions for Buffered Devices	5-46
<b>Chapter 6. Token-Ring Resources</b>	6-1
Defining Token-Ring Resources	6-3
NDF-Generated Additions for Token-Ring Resources	6-4
Defining Token-Ring Physical Connections	6-6
Defining Backup Token-Ring Interface Couplers	6-15
Duplicate TIC Addressing	6-16
Defining Token-Ring Logical Connections	6-20
Unassigned Logical Line Pools	6-24
Defining Peripheral Device Addresses for VTAM	6-25
Sample Token-Ring Peripheral Resource Definitions	6-26
Token-Ring Subarea Links	6-27
Defining Token-Ring Physical Subarea Connections	6-28
Defining Token-Ring Logical Subarea Connections	6-29
Differences between Subarea and Peripheral Logical Connections	6-33
3746 Model 900 Service Processor LAN	6-34
Converting Existing Token-Ring Resources to 3746 Model 900 Token-Ring Resources	6-35
Performance Characteristics	6-39
Data Transfer	6-39
Timers for Logical Connections	6-44
Logical Line Error Recovery and Retries	6-47
Logical Line Retries	6-47
Remote Loading and Activation over a Token-Ring Line	6-48
Sample Token-Ring Resource Definitions	6-48
<b>Chapter 7. Integrated Services Digital Network (ISDN) Resources</b>	7-1
Introduction to 3746 Model 900 ISDN	7-1
What Is ISDN?	7-1
NCP ISDN Terms	7-3
Definition Statements for Defining ISDN Resources	7-4
Defining ISDN Physical Lines (D-Channels)	7-5
NDF-Added Keywords for ISDN Physical Lines (D-Channels)	7-10
Sample Definition of an ISDN Physical Line (D-Channel)	7-10
Defining ISDN B-Channels	7-10
NDF-Added Keywords for ISDN B-Channels	7-12
Sample Definition of an ISDN B-Channel	7-12
Defining ISDN Logical Lines	7-13
Defining ISDN Logical Subarea Lines	7-13
NDF-Added Keywords for ISDN Logical Subarea Lines	7-18



Sample Definition of an ISDN Subarea Link . . . . .	7-18
Defining ISDN Logical Peripheral Lines . . . . .	7-18
NDF-Added Keywords for ISDN Logical Peripheral Lines . . . . .	7-21
Sample Definition of a ISDN Peripheral Link . . . . .	7-21
Unassigned Logical Line Pools . . . . .	7-22
Defining Device Addresses to VTAM . . . . .	7-22
Establishing a Connection . . . . .	7-26
Controlling ISDN B-Channel Connections . . . . .	7-28
Defining ISDN Subarea Connectivity through a Terminal Adapter or BAN Device . . . . .	7-31
Remote Loading and Activation over an ISDN Line . . . . .	7-32
Coding ISDN Definitions for the Best Performance . . . . .	7-33
Performance-Related Keywords . . . . .	7-33
ISDN Accounting . . . . .	7-34
Sample ISDN Definition . . . . .	7-35
<b>Chapter 8. Type 2.1 Node Support . . . . .</b>	<b>8-1</b>
Defining Type 2.1 Physical Units and Independent Logical Units . . . . .	8-1
Type 2.1 Support Functions . . . . .	8-6
Independent Logical Unit Resource Pools . . . . .	8-10
Independent LUs in a Nonnative Network . . . . .	8-11
NCP and VTAM As a Composite Type 2.1 Node . . . . .	8-13
Generating APPN and LEN Support . . . . .	8-14
Generating APPN HPR Support in NCP . . . . .	8-14
<b>Chapter 9. Block Handlers . . . . .</b>	<b>9-1</b>
Defining a Block Handler . . . . .	9-1
Defining a Block Handler Set . . . . .	9-4
Defining Resources to Use a Block Handler Set . . . . .	9-6
<b>Chapter 10. Dynamic Reconfiguration . . . . .</b>	<b>10-1</b>
Adding and Deleting Dynamically Reconfigurable Resources . . . . .	10-1
Defining Dynamically Reconfigurable Physical Unit Resources . . . . .	10-2
Defining Dynamically Reconfigurable Logical Unit Resources . . . . .	10-4
Dynamic Reconfiguration for SDLC 3270 Devices . . . . .	10-5
Dynamic Reconfiguration for Frame-Relay Devices . . . . .	10-5
Dynamic Reconfiguration for Frame-Relay Internet Devices . . . . .	10-6
Defining NCP Channel Connections from the Host . . . . .	10-7
<b>Chapter 11. Routes between Subareas . . . . .</b>	<b>11-1</b>
Transmission Groups Between Subareas . . . . .	11-1
Explicit Routes . . . . .	11-1
Guidelines for Defining Explicit Routes . . . . .	11-3
Defining Explicit Routes . . . . .	11-4
Virtual Routes . . . . .	11-10
Dynamic Path Update . . . . .	11-13
Defining Routes for Mixed-Level Networks . . . . .	11-14
Using IBM Network Design Products to Define Routes . . . . .	11-15
<b>Chapter 12. Connections between Subarea Nodes . . . . .</b>	<b>12-1</b>
Subarea Links and Link Stations . . . . .	12-1
Point-to-Point Subarea Links . . . . .	12-2
Multipoint Subarea Links . . . . .	12-2
Defining SDLC Subarea Links . . . . .	12-3

Defining Configurable Point-to-Point Subarea Links . . . . .	12-8
Defining Nonconfigurable Point-to-Point Subarea Links . . . . .	12-10
Defining Multipoint Subarea Links . . . . .	12-11
Defining Switched Subarea Links . . . . .	12-13
Token-Ring Subarea Links . . . . .	12-15
Frame-Relay Subarea Links . . . . .	12-15
ISDN Subarea Links . . . . .	12-15
Transmission Groups . . . . .	12-15
Single-Link Transmission Groups . . . . .	12-16
Multilink Transmission Groups . . . . .	12-16
MLTG Segment Size . . . . .	12-23
Parallel Transmission Groups . . . . .	12-26
Power-Off Feature in a Link-Attached Controller . . . . .	12-28
Remote Loading and Activation of a Link-Attached NCP . . . . .	12-29
Defining Casual Connection Links between Subareas . . . . .	12-29
<b>Chapter 13. Customized Functions . . . . .</b>	<b>13-1</b>
User Line Control . . . . .	13-1
Programmed Resources . . . . .	13-3
Network Addressable Units . . . . .	13-4
User Channel Control Code . . . . .	13-4
Entry Points and Library Member Names . . . . .	13-5
Library Members That Contain Linkage Editor Statements . . . . .	13-6
NDF Standard Attachment Facility . . . . .	13-8
<b>Chapter 14. Interconnected Networks . . . . .</b>	<b>14-1</b>
Defining a Gateway NCP . . . . .	14-2
Defining Nonnative Networks . . . . .	14-4
Defining Connections to Adjacent Networks . . . . .	14-5
Defining Cross-Network Sessions . . . . .	14-8
Address Control Blocks . . . . .	14-8
Half-Session Control Blocks . . . . .	14-10
Placement of GWNAU Definition Statements . . . . .	14-12
Defining Cross-Network Paths . . . . .	14-15
Defining Dynamic Network Allocation . . . . .	14-18
Defining Cross-Network Paths to VTAM . . . . .	14-23
Defining Cross-Network Session Pacing . . . . .	14-24
Defining Gateway Session Accounting and Accounting Exit Routines . . . . .	14-24
<b>Chapter 15. Internet Resources . . . . .</b>	<b>15-1</b>
Definition Statements for NCP Internet Resources . . . . .	15-3
Specifying Internet Addresses . . . . .	15-4
Defining the Owing TCP/IP Host . . . . .	15-7
Defining NCST Session Interfaces . . . . .	15-8
Defining 370 I/O Channels for IP . . . . .	15-18
Defining ESCON Channels for IP . . . . .	15-22
Defining Ethernet-Type LAN Attachments . . . . .	15-25
Defining NTRI Attachments for IP . . . . .	15-31
Defining an Internal NCP to Model 900 Point-to-Point IP Connection . . . . .	15-39
Defining Frame-Relay Attachments for IP . . . . .	15-44
Defining Internet Routes . . . . .	15-52
Routes Defined by NCPROUTE through RIP . . . . .	15-53
Routes Implicitly Defined by NCP Internet Interfaces . . . . .	15-53
Defining Routes Explicitly . . . . .	15-54

Dynamic Reconfiguration of Frame Relay Internet Hosts . . . . .	15-57
Migrating Internet Resources to NCP V7R1 and Later Releases . . . . .	15-57
Coding Internet Route Definitions for Best Performance . . . . .	15-59
Sample Internet Resource Configuration and Definitions . . . . .	15-60
<b>Chapter 16. Frame-Relay Resources . . . . .</b>	<b>16-1</b>
Introduction to Frame Relay . . . . .	16-1
What Is Frame Relay? . . . . .	16-1
NCP Frame-Relay Terms . . . . .	16-5
Definition Statements for Defining NCP Frame-Relay Resources . . . . .	16-7
Defining Frame-Relay Physical Lines . . . . .	16-8
Defining Nonswitched Frame-Relay Physical Lines . . . . .	16-8
Defining Switched Frame-Relay Physical Lines . . . . .	16-18
NDF-Added Keywords for Frame-Relay Physical Lines . . . . .	16-20
Sample Definition of a Frame-Relay Physical Line . . . . .	16-21
Defining Automatic Frame-Relay Backup over an ISDN . . . . .	16-22
Defining Frame-Relay Logical Subarea Lines . . . . .	16-27
Determining a T1 (Reply) Timer Value for a Local Link . . . . .	16-36
NDF-Added Keywords for Frame-Relay Logical Subarea Lines . . . . .	16-37
Converting SDLC Subarea Links to Frame Relay . . . . .	16-38
Sample Definition of a Frame-Relay Subarea Link . . . . .	16-42
Sample Definition of a Frame-Relay BAN Subarea Link . . . . .	16-43
Defining Frame-Relay Logical Peripheral Lines . . . . .	16-45
Unassigned Logical Line Pools . . . . .	16-50
Defining Peripheral Device Addresses to VTAM . . . . .	16-51
NDF-Added Keywords for Frame-Relay Logical Peripheral Lines . . . . .	16-53
Sample Definitions of Frame-Relay Peripheral Links . . . . .	16-54
Defining Frame Handler Connections . . . . .	16-57
Dynamic Reconfiguration . . . . .	16-61
Sample Definition of Frame Handler Connections . . . . .	16-62
Defining NTRI Attachments for a Frame-Relay Network . . . . .	16-63
Defining NTRI Physical Links . . . . .	16-63
Defining NTRI Frame Handler Logical Links . . . . .	16-66
NDF-Added Keywords for NTRI Frame Handler Logical Lines . . . . .	16-70
3746 Model 900 Frame Relay . . . . .	16-72
Remote Loading and Activation over a Frame-Relay Line . . . . .	16-73
Coding Frame-Relay Definitions for the Best Performance . . . . .	16-74
Performance-Related Keywords . . . . .	16-74
Sample Frame-Relay Configurations and Definitions . . . . .	16-77
Frame-Relay Network with Subarea Link Support . . . . .	16-77
Frame-Relay Network with Frame-Relay Switching Support . . . . .	16-78
Frame-Relay Network with FHSPs and TESP s . . . . .	16-81
Frame-Relay Network with 3746 Model 900 . . . . .	16-85
Frame-Relay Network with Internal PVC Segment between 3746 Model 900 and NCP on a 3745 . . . . .	16-89
Switched Frame-Relay Physical Line . . . . .	16-93

---

## Part 3. Defining Pre-SNA NCP Resources

<b>Chapter 17. Multiple Terminal Access Terminals . . . . .</b>	<b>17-1</b>
Multiple Terminal Access Sign-on Procedures . . . . .	17-1
Overview of Procedures . . . . .	17-1
Errors in the Sign-on Procedure . . . . .	17-2

Defining MTA Tables . . . . .	17-3
MTA Device Characteristics . . . . .	17-5
Terminal Type . . . . .	17-6
Polling Character . . . . .	17-7
Defining an MTA Table . . . . .	17-7
<b>Chapter 18. Teletypewriter Exchange Service . . . . .</b>	<b>18-1</b>
Defining TWX Terminal Characteristics . . . . .	18-1
TWX Terminals Attached to a Switched Telecommunication Link . . . . .	18-2
TWX Terminals Attached to MTA Lines . . . . .	18-4
<b>Chapter 19. World Trade Teletypewriter Terminals . . . . .</b>	<b>19-1</b>
Character Transmission . . . . .	19-1

---

## Part 4. Defining Emulation Program Resources

<b>Chapter 20. BSC and Start-Stop Devices Operating in PEP Environment . . . . .</b>	<b>20-1</b>
Emulation Subchannel . . . . .	20-1
BSC Telecommunication Links in PEP Mode . . . . .	20-3
WTTY Terminals in PEP Mode . . . . .	20-4
Switched Telecommunication Links . . . . .	20-4
Modems . . . . .	20-4
Devices . . . . .	20-5
Control Units . . . . .	20-5
Data Transmission Characteristics . . . . .	20-6
Character Transmission . . . . .	20-7
Timeouts . . . . .	20-7
Sample Definition of Emulation Mode Subchannels . . . . .	20-8
<b>Chapter 21. Defining a Standalone EP Network . . . . .</b>	<b>21-1</b>
How Resources Are Defined to EPSA . . . . .	21-3
Defining Your System . . . . .	21-3
Defining Your Network Configuration . . . . .	21-4
Coding LINE Keywords on the GROUP Definition Statements . . . . .	21-4
GROUP Definition Statement . . . . .	21-6
LINE Definition Statement . . . . .	21-6
Sequence of LINE and GROUP . . . . .	21-7
Defining Your Generation Procedure . . . . .	21-8
Defining the End of Your Generation . . . . .	21-8
Defining Your System . . . . .	21-8
Diagnostic Operations for the Generation Procedure . . . . .	21-9
Verification of the Generation Definition . . . . .	21-10
Communication Controller . . . . .	21-11
Diagnostic Aids . . . . .	21-13
EP Buffers . . . . .	21-14
Defining Characteristics and Functions Common to BSC and SS Devices . . . . .	21-14
Control Units . . . . .	21-14
Line Characteristics . . . . .	21-14
Switched Lines . . . . .	21-15
Modem Characteristics . . . . .	21-15
Modems for a Switched Line . . . . .	21-16
Device Type . . . . .	21-16
Defining Characteristics and Functions for BSC Devices . . . . .	21-16

Line Priority	21-16
Device Features	21-17
Modems	21-17
Communication Controllers Connected by a BSC Line	21-17
Line Characteristics	21-17
Buffer Size	21-18
Data Characteristics	21-18
Defining Characteristics and Functions for SS Devices	21-19
Response Mode	21-19
Switched Lines	21-19
Device Features	21-20
Data Characteristics	21-20
Character Transmission	21-20
Timeouts	21-21
WTTY Terminals	21-21
Performance Characteristics	21-21

---

## Part 5. Defining Diagnostic Aids and Network Management Facilities

<b>Chapter 22. Diagnostic Operations for the Generation Procedure</b>	22-1
Procedure Tracing	22-1
Parameter Tracing	22-1
Data Tracing	22-1
Data Printing	22-2
Global Tracing	22-2
<b>Chapter 23. Defining Diagnostic Aids</b>	23-1
Channel Adapter Trace	23-1
Channel Adapter IOH Trace	23-1
Address Trace	23-2
Branch Trace	23-2
Diagnostic Tests and Traces	23-2
Link Problem Determination Aid	23-4
Diagnostic Aids	23-4
LPDA Mode	23-5
Migration Mode (LPDA-1)	23-6
Normal Mode (LPDA-2)	23-10
Switched Telecommunication Links	23-15
Multiple Local Modem Support	23-16
Monitoring Virtual Route Congestion	23-18
Deactivating an Out-of-Sequence Virtual Route	23-18
Monitoring Transmission Group Performance	23-18
Monitoring for Excessive Buffer Usage by a Peripheral Resource	23-19
<b>Chapter 24. Network Performance</b>	24-1
Defining NCP Buffer Size	24-1
Reaching the Buffer Limit	24-3
Data Flow Control	24-3
Timeout Values	24-4
Service Order Table	24-4
Defining Session Pacing	24-6
Data Transfer	24-6
Timeouts	24-10

Initially Inhibiting NCP Functions	24-12
Transmission Interrupts	24-14
Controlling Adapter Overrun Errors	24-14
Session Accounting	24-15
Network Performance Data Collection	24-16
Basic Data Collection	24-16
Data Collection by Transmission Priority	24-18
Session Accounting for IBM Special Products or User-Written Code	24-19
MTA Terminals	24-20
Link Session Priority	24-21
<b>Chapter 25. Backup and Recovery Procedures</b>	<b>25-1</b>
Defining Automatic Network Shutdown	25-1
Error Recovery and Recording	25-4
Backup Sessions for SDLC Devices	25-6

---

## Appendixes

<b>Appendix A. NCP V7R8 Sample Generation Definitions</b>	<b>A-1</b>
Sample Network Connections	A-4
NCP A03	A-4
NCP A04	A-4
NCP A31	A-5
NCP B31	A-5
NCP B75	A-5
NCP C04	A-6
NCP A03 Sample Generation Definition	A-7
NCP A04 Sample Generation Definition	A-39
NCP A31 Sample Generation Definition	A-82
NCP B31 Sample Generation Definition	A-128
NCP B75 Sample Generation Definition	A-155
NCP C04 Sample Generation Definition	A-191
<b>Appendix B. SSP Generated Inputs to NETDA/2</b>	<b>B-1</b>

---

## List of Abbreviations, Glossary, Bibliography, and Index

<b>List of Abbreviations</b>	<b>X-3</b>
<b>Glossary</b>	<b>X-7</b>
<b>Bibliography</b>	<b>X-35</b>
NCP, SSP, and EP Library	X-35
Other Networking Products' Libraries	X-36
Networking Library	X-36
NTuneMON Library	X-36
SNA Services Library (formerly VTAM Library)	X-36
NPSI Library	X-36
NetView Library	X-36
NPM Library	X-37
NTO Library	X-37
NRF Library	X-37

Related Publications . . . . .	X-37
IBM 3745 Communication Controller Publications . . . . .	X-37
IBM 3746 Model 900 and Model 950 Publications . . . . .	X-38
MVS/ESA Publications . . . . .	X-38
SNA Publications . . . . .	X-38
TCAM Publications . . . . .	X-38
TCP/IP Publications . . . . .	X-38
<b>Index . . . . .</b>	<b>X-39</b>





---

# Figures

0-1.	Symbols Used in Illustrations . . . . .	xxxi
1-1.	Determination of Primary and Secondary Roles by Communication Controllers . . . . .	1-13
1-2.	Example: Defining a Stand-Alone SDLC Line Group . . . . .	1-15
1-3.	Example: Defining a Stand-Alone MTA Line Group . . . . .	1-16
2-1.	Example: Defining a New Generation Definition . . . . .	2-2
2-2.	Example: Packed NEWDEFN File . . . . .	2-3
2-3.	Example: Defining a Reusable NEWDEFN File . . . . .	2-3
2-4.	Example: Reusable NEWDEFN File Created by NDF . . . . .	2-4
2-5.	NCP in Channel-Attached and Link-Attached Controllers . . . . .	2-9
2-6.	Example: Defining the NCP Environment . . . . .	2-10
2-7.	Example: Defining the Autocopy Function . . . . .	2-14
2-8.	Example: NEWDEFN File Created by the Autocopy Function . . . . .	2-15
2-9.	Example: Defining the Autoline Function . . . . .	2-17
2-10.	Example: NEWDEFN File Created by the Autoline Function . . . . .	2-18
3-1.	Example: Defining a Communication Controller . . . . .	3-2
3-2.	IBM 3745-410, 3745-41A, 3745-610, or 3745-61A in Twin-in-Dual Mode . . . . .	3-3
3-3.	IBM 3745-410, 3745-41A, 3745-610, or 3745-61A in Twin-in-Standby Mode . . . . .	3-4
3-4.	IBM 3745-410, 3745-41A, 3745-610, or 3745-61A in Twin-in-Backup Mode . . . . .	3-4
3-5.	IBM Communication Controller in Twin-in-Backup Mode with 3746 Model 900 Resources . . . . .	3-8
3-6.	Example: Defining Fallback and Switchback for 3746 Model 900 Resources . . . . .	3-9
4-1.	370 I/O Channel Attachments . . . . .	4-1
4-2.	Example: Defining Subarea Channel Links . . . . .	4-4
4-3.	Example: Defining Peripheral Channel Links . . . . .	4-7
4-4.	Subarea and Peripheral Channel Adapter Connections . . . . .	4-8
4-5.	Example: Defining a Type 7 Channel Adapter . . . . .	4-8
4-6.	System/370 Multidrop Topology . . . . .	4-9
4-7.	ESCON Star Topology . . . . .	4-10
4-8.	ESCON Channel Configuration with Two Hosts and Two NCPs . . . . .	4-11
4-9.	ESCON Channel Configuration with Two Hosts and One NCP . . . . .	4-12
4-10.	Example: Defining an ESCON Physical Line . . . . .	4-14
4-11.	ESCON Logical Line that Supports an NCP-VTAM Subarea Link . . . . .	4-17
4-12.	Example: Defining an ESCON Logical Line . . . . .	4-18
4-13.	Example: Converting a System/370 I/O Channel to an ESCON Link (Before) . . . . .	4-19
4-14.	Example: Converting a System/370 I/O Channel to an ESCON Link (After) . . . . .	4-21
4-15.	ESCON Channel Configuration (with LINE and STATION Addresses) . . . . .	4-23
4-16.	Relationship between IOCDS, NCP, and MOSS-E . . . . .	4-24
4-17.	Example: Defining Subarea Addressability . . . . .	4-27
4-18.	Example: Defining Concurrent Sessions . . . . .	4-28
5-1.	Example: Defining Nonswitched Telecommunication Links . . . . .	5-4
5-2.	Example: Defining Switched Telecommunication Links . . . . .	5-7
5-3.	Example: Defining V.25 Bis . . . . .	5-10
5-4.	Example: Defining SMMF for a Nonswitched SDLC Subarea Link . . . . .	5-13

5-5.	Example: Defining a Switched SDLC Subarea Link . . . . .	5-15
5-6.	Example: Defining SMMF for a Nonswitched Peripheral Link . . . . .	5-16
5-7.	Example: SMMF Activating a Subarea Channel Link . . . . .	5-17
5-8.	Example: SMMF Activating an ESCON Link . . . . .	5-19
5-9.	Example: Converting an SDLC Line to a 3746 Model 900 SDLC Line (Before) . . . . .	5-21
5-10.	Example: Converting an SDLC Line to a 3746 Model 900 SDLC Line (After) . . . . .	5-21
5-11.	Modem Configuration . . . . .	5-23
5-12.	Example: Defining a Modem . . . . .	5-23
5-13.	Channelized Modem Configuration . . . . .	5-24
5-14.	Example: Defining a Channelized Modem . . . . .	5-24
5-15.	Switched Network Backup . . . . .	5-25
5-16.	Example: Defining Switched Network Backup . . . . .	5-25
5-17.	BSC or Start-Stop Devices . . . . .	5-29
5-18.	Example: Defining BSC or Start-Stop Devices on Nonswitched Links	5-30
5-19.	BSC or Start-Stop Devices Attached to Switched Telecommunication Links . . . . .	5-32
5-20.	Example: Defining BSC and Start-Stop Devices on Switched Links	5-32
5-21.	SDLC Devices Attached to Nonswitched Telecommunication Links	5-34
5-22.	Example: Defining SDLC Devices Attached to Nonswitched Links . .	5-34
5-23.	SDLC Devices Attached to Switched Telecommunication Links . . .	5-35
5-24.	Example: Defining SDLC Devices on Switched Telecommunication Links . . . . .	5-36
5-25.	Example: Defining Polling and Addressing . . . . .	5-42
5-26.	Example: Defining the IBM 3174 Group Poll . . . . .	5-43
5-27.	Example: Defining Data Characteristics . . . . .	5-45
5-28.	Example: Defining the End of Transmission . . . . .	5-45
5-29.	Example: Defining the Delay between Successive Transmissions . .	5-46
6-1.	Token-Ring Physical and Logical Connections . . . . .	6-3
6-2.	NDF-Generated Keywords for Token-Ring Physical Lines . . . . .	6-5
6-3.	NDF-Generated Keywords for Token-Ring Logical Peripheral Lines . .	6-6
6-4.	NDF-Generated Keywords for Token-Ring Logical Subarea Lines . . .	6-6
6-5.	Type 2 and Type 3 Token-Ring Physical Connections . . . . .	6-14
6-6.	Example: Defining Type 2 and Type 3 Token-Ring Physical Connections . . . . .	6-14
6-7.	Duplicate TIC Configuration for Logical Peripheral Connections . . .	6-17
6-8.	Example: Defining a Duplicate TIC Configuration for Logical Peripheral Connections . . . . .	6-18
6-9.	Duplicate TIC Configuration for Logical Subarea Connections . . . .	6-19
6-10.	Example: Defining a Duplicate TIC Configuration for Logical Subarea Connections . . . . .	6-20
6-11.	Token-Ring Logical Connections . . . . .	6-23
6-12.	Example: Defining a Token-Ring Logical Connection . . . . .	6-24
6-13.	Example: Defining NTRI with Peripheral Lines . . . . .	6-27
6-14.	Token-Ring Subarea Physical and Logical Lines . . . . .	6-28
6-15.	Example: Defining Token-Ring Physical Subarea Connections . . . .	6-29
6-16.	Token-Ring Logical Subarea Connections . . . . .	6-33
6-17.	Example: Defining Token-Ring Logical Subarea Connections . . . . .	6-33
6-18.	Example: Converting a Type 2 TIC to a Type 3 TIC (Before) . . . . .	6-36
6-19.	Example: Converting a Type 2 TIC to a Type 3 TIC (After) . . . . .	6-38
6-20.	Example: Defining Token-Ring Performance . . . . .	6-44
6-21.	Example: Defining Timers for Logical Connections . . . . .	6-47
6-22.	Example: Defining Logical Connection Error Recovery and Retries	6-47

6-23.	Token-Ring Physical and Logical Lines . . . . .	6-48
6-24.	Example: Defining Token-Ring Physical and Logical Lines . . . . .	6-49
7-1.	ISDN Connections . . . . .	7-2
7-2.	NDF-Added Keywords for ISDN D-Channels . . . . .	7-10
7-3.	Example: Defining an ISDN Physical Line (D-Channel) . . . . .	7-10
7-4.	NDF-Added Keywords for ISDN B-Channels . . . . .	7-12
7-5.	Example: Defining ISDN B-Channels . . . . .	7-13
7-6.	NDF-Added Keywords for ISDN Logical Subarea Lines . . . . .	7-18
7-7.	Example: Defining an ISDN Subarea Link . . . . .	7-18
7-8.	NDF-Added Keywords for ISDN Logical Peripheral Lines . . . . .	7-21
7-9.	Example: Defining an ISDN Peripheral Link . . . . .	7-21
7-10.	Example of a Frame-Relay/ISDN Subarea Connection through a Terminal Adapter . . . . .	7-31
7-11.	Example of a Token-Ring/ISDN Subarea Connection through a BAN Device . . . . .	7-31
7-12.	Connection through an ISDN . . . . .	7-35
7-13.	Example: Defining ISDN Resources . . . . .	7-36
8-1.	Type 2.1 Physical Unit Configuration . . . . .	8-2
8-2.	Type 2.1 Peripheral Node Configuration . . . . .	8-5
8-3.	Example: Defining a Type 2.1 Physical Unit . . . . .	8-6
8-4.	Multiple and Parallel Sessions between Logical Units . . . . .	8-7
8-5.	Example: Defining Parallel and Multiple Sessions . . . . .	8-10
8-6.	Independent Logical Unit Control Block Pools . . . . .	8-11
8-7.	The NCP Role in an APPN Network . . . . .	8-14
9-1.	Example: Defining a Block Handler and Block Handler Set . . . . .	9-5
9-2.	Example: Defining Resources That Use a Block Handler Set . . . . .	9-7
10-1.	Example: Defining the Reconfiguration of a Physical Unit . . . . .	10-2
10-2.	Example: Defining the Reconfiguration of a Logical Unit . . . . .	10-2
10-3.	Example: Defining the Reconfiguration of Link Devices . . . . .	10-3
10-4.	Example: Adding and Deleting Logical Units . . . . .	10-5
11-1.	Explicit Routes to Connect Five Subareas in One Network . . . . .	11-2
11-2.	Explicit Routes between NCP Subarea 5 and VTAM Subarea 1 . . . . .	11-5
11-3.	Example: Defining Explicit Routes between NCP Subarea 5 and VTAM Subarea 1 . . . . .	11-5
11-4.	Explicit Route between VTAM Subarea 2 and VTAM Subarea 1 . . . . .	11-6
11-5.	Example: Defining an Explicit Route between NCP Subarea 2 and VTAM Subarea 1 . . . . .	11-7
11-6.	Explicit Route ER2 between VTAM Subarea 2 and VTAM Subarea 1 . . . . .	11-7
11-7.	Example: Defining Explicit Route ER2 . . . . .	11-8
11-8.	Four Explicit Routes in One Network . . . . .	11-8
11-9.	Example: Defining Four Explicit Routes in One Network . . . . .	11-9
11-10.	Virtual Route between NCP Subarea 5 and VTAM Subarea 1 . . . . .	11-12
11-11.	Example: Defining a Virtual Route between NCP Subarea 5 and VTAM Subarea 1 . . . . .	11-12
11-12.	Example: Defining Dynamic Path Update . . . . .	11-14
12-1.	Link Stations at Ends of Subarea Links . . . . .	12-1
12-2.	Multipoint Subarea Link . . . . .	12-3
12-3.	Point-to-Point Subarea Links . . . . .	12-8
12-4.	Example: Defining Configurable Point-to-Point Subarea Links . . . . .	12-9
12-5.	Example: Defining Point-to-Point Subarea Links Using MODULO=128 . . . . .	12-9
12-6.	Example: Defining NCPs with Different MODULO Values . . . . .	12-10
12-7.	Example: Defining Point-to-Point Subarea Links for a Primary NCP . . . . .	12-11

12-8.	Example: Defining Point-to-Point Subarea Links for a Secondary NCP	12-11
12-9.	Multipoint Subarea Link Configuration	12-12
12-10.	Example: Defining a Multipoint Subarea Link for a Primary NCP	12-12
12-11.	Example: Defining a Multipoint Subarea Link for a Secondary NCP	12-13
12-12.	Switched Subarea Link Configuration	12-14
12-13.	Example: Defining a Switched Subarea Link	12-15
12-14.	Multilink Transmission Group (MLTG)	12-19
12-15.	Example: Defining an MLTG	12-20
12-16.	Mixed-Media MLTG	12-20
12-17.	Coding Example: Defining a Mixed-Media MLTG	12-21
12-18.	PIU Segment Size	12-25
12-19.	Parallel Transmission Groups	12-27
12-20.	Example: Defining Parallel Transmission Groups	12-28
12-21.	Casual Connection Links Between Subareas	12-30
12-22.	Casual Connection between Composite Type 2.1 Nodes	12-34
12-23.	Example: Defining the Primary NCP in a Casual Connection	12-34
12-24.	Example: Defining the Secondary NCP in a Casual Connection	12-35
14-1.	Two Networks Connected by a Gateway NCP and a Gateway SSCP	14-2
14-2.	Gateway NCP in a Native Network Configuration	14-3
14-3.	Example: Defining a Gateway NCP	14-3
14-4.	Gateway NCP in Nonnative Network Configuration	14-5
14-5.	Example: Defining a Nonnative Network	14-5
14-6.	Link Station Representing NCP in Nonnative Network	14-6
14-7.	Link Stations Representing Adjacent Gateway NCPs	14-7
14-8.	Link Station in Nonnative Network	14-7
14-9.	Example: Defining Nonnative Network Connections	14-7
14-10.	Address Control Blocks and HSCBs Used to Represent Cross-Network Sessions	14-8
14-11.	Logical Units Requiring Cross-Network Session Specifications	14-12
14-12.	Example: Defining Cross-Network Session Values	14-13
14-13.	Example: Defining Dynamic Allocation of Addresses	14-13
14-14.	Example: Defining Cross-Network Sessions in the Gateway NCP	14-14
14-15.	Example: Defining a Logical Unit in the Gateway NCP	14-14
14-16.	An Interconnected Network with a Cross-Network Path	14-15
14-17.	Example: Defining Cross-Network Paths	14-18
14-18.	Example: Defining the Number of Dynamically Added Networks	14-19
14-19.	Back-to-Back Configuration with Five NCPs	14-20
14-20.	Example: Defining PATH Statements for Dynamically Added Networks	14-21
14-21.	Back-to-Back Configuration with Five NCPs (Optimized)	14-22
14-22.	Example: Defining PATH Statements to a Dynamically Added Network (Optimized)	14-23
15-1.	NCP with an NCST Session and LAN Attachments	15-2
15-2.	Sample Internet Subnetwork Mask	15-6
15-3.	NDF-Added Keywords for NCST Interfaces	15-11
15-4.	NCST Interfaces and LU-LU Sessions	15-13
15-5.	Example: Defining NCST Interfaces and LU-LU Sessions	15-14
15-6.	NDF-Added Keywords for Ethernet-Type LAN Attachments	15-28
15-7.	Ethernet-Type LAN Attachments	15-29
15-8.	Example: Defining Ethernet-Type LAN Attachments	15-30
15-9.	NTRI Internet Attachment	15-36
15-10.	Coding Example: Defining a NTRI Internet Attachment	15-38

15-11.	Sample IP Network with an Internal NCP to Model 900 Point-to-Point IP Connection . . . . .	15-39
15-12.	Coding Example: Defining an Internal NCP to Model 900 Point-to-Point IP Connection . . . . .	15-44
15-13.	Frame-Relay Internet Attachments . . . . .	15-50
15-14.	Coding Example: Defining Frame-Relay Internet Attachments over Switched and Nonswitched Frame-Relay Physical Lines . . . . .	15-51
15-15.	Internet Routing to a Subnetwork . . . . .	15-56
15-16.	Coding Example: Defining an Internet Route to a Subnetwork . . . . .	15-57
15-17.	Coding Example: Coding Keywords for Internet Performance . . . . .	15-60
15-18.	Internet Configuration with NCPs, MVS hosts, Ethernet-Type LANs, and Token Rings . . . . .	15-61
15-19.	Example: Defining Internet Resources to NCP . . . . .	15-63
16-1.	Frame-Relay Connections . . . . .	16-3
16-2.	DLCIs for Frame-Relay Connections . . . . .	16-4
16-3.	NDF-Added Keywords for Frame-Relay Physical Lines . . . . .	16-21
16-4.	Example: Defining a Frame-Relay HPTSS Physical Line . . . . .	16-21
16-5.	Example: Defining a Frame-Relay 3746 Model 900 Physical Line . . . . .	16-22
16-6.	Frame-Relay Backup over an ISDN . . . . .	16-23
16-7.	Example: Defining a Frame-Relay Line with ISDN Backup . . . . .	16-27
16-8.	Frame-Relay Subarea Links . . . . .	16-28
16-9.	Frame-Relay Subarea Links in MLTGs . . . . .	16-28
16-10.	BAN for Subarea Links . . . . .	16-29
16-11.	Sample to illustrate how to code the T1 (reply) timer value . . . . .	16-36
16-12.	NDF-Added Keywords for Frame-Relay Logical Subarea Lines . . . . .	16-38
16-13.	Example: Converting an SDLC Subarea Link to Frame Relay (Before) . . . . .	16-39
16-14.	Example: Converting an SDLC Subarea Link to Frame Relay (After) . . . . .	16-41
16-15.	Frame-Relay Logical Subarea Line . . . . .	16-42
16-16.	Example: Defining a Frame-Relay Subarea Link . . . . .	16-42
16-17.	Example: Defining a Frame-Relay BAN Subarea Link . . . . .	16-44
16-18.	Frame-Relay Peripheral Links . . . . .	16-46
16-19.	NDF-Added Keywords for Frame-Relay Logical Peripheral Lines . . . . .	16-53
16-20.	Frame-Relay Peripheral Link to a Directly Attached Device . . . . .	16-54
16-21.	Example: Defining a Frame-Relay Peripheral Link to a Directly Attached Device . . . . .	16-55
16-22.	Frame-Relay Peripheral Link to a Device Attached through a Frame-Relay Network . . . . .	16-55
16-23.	Example: Defining a Frame-Relay Peripheral Link to a Device Attached through a Frame-Relay Network . . . . .	16-56
16-24.	Reliable Frame Handler Transport between Frame-Relay Terminating Equipment Devices . . . . .	16-58
16-25.	Frame-Relay Routing Paths . . . . .	16-62
16-26.	Example: Defining FRFH Virtual Circuits . . . . .	16-62
16-27.	NDF-Generated Keywords for Token-Ring Logical Frame-Relay Lines . . . . .	16-70
16-28.	NTRI Frame Handler Attachment . . . . .	16-70
16-29.	Example: Defining a NTRI Frame-Relay Attachment . . . . .	16-71
16-30.	Frame-Relay Subarea Connection with TESP s . . . . .	16-77
16-31.	Example: Frame-Relay Subarea Link Connection . . . . .	16-78
16-32.	Frame-Relay Switching Network with FHSP s . . . . .	16-78
16-33.	Example: Frame-Relay Network with FHSP s (NCP1) . . . . .	16-79
16-34.	Example: Frame-Relay Network with FHSP s (NCP2) . . . . .	16-80
16-35.	Frame-Relay Network with FHSP s and TESP s . . . . .	16-82

16-36.	Example: Frame-Relay Network with FHSPs and TESP <sub>s</sub> (NCP <sub>1</sub> )	16-82
16-37.	Example: Frame-Relay Network with FHSPs and TESP <sub>s</sub> (NCP <sub>2</sub> )	16-84
16-38.	Frame-Relay Network with 3746 Model 900 FHSP <sub>s</sub> and TESP <sub>s</sub> in NCP <sub>2</sub>	16-85
16-39.	Example: Frame-Relay Network with 3746 Model 900 FHSP <sub>s</sub> and TESP <sub>s</sub> in NCP <sub>2</sub>	16-87
16-40.	Frame-Relay Network with Internal PVC Segment between 3746 Model 900 and NCP on a 3745	16-89
16-41.	Example: Frame-Relay Network with Internal PVC Segment between 3745 and 3746 Model 900 (NCP <sub>1</sub> )	16-90
16-42.	Example: Frame-Relay Network with Internal PVC Segment between 3745 and 3746 Model 900 (NCP <sub>2</sub> )	16-91
16-43.	Switched Frame-Relay Physical Line	16-93
16-44.	Example: 3745 Switched Frame-Relay Physical Line	16-93
16-45.	Example: 3746 Model 900 Switched Frame-Relay Physical Line	16-94
17-1.	Example: Defining MTALCST for a 2741 Using BCD Code	17-4
17-2.	Example: Defining MTATABL for a 2741 Using BCD Code	17-4
17-3.	Example: Defining Two MTALCST Statements	17-4
18-1.	Example: Defining TWX Terminal Features	18-2
20-1.	Emulation Mode Resources	20-1
20-2.	Example: Defining Telecommunication Links in PEP Mode	20-3
20-3.	Example: Defining Emulation Mode Subchannels	20-8
23-1.	LPDA-1 Channelized and Tailed Modems on SDLC or BSC Links	23-8
23-2.	Example: Defining an LPDA-1 Channelized Modem Link	23-9
23-3.	LPDA-1 Nontailed Modems on SDLC or BSC Links	23-10
23-4.	Example: Defining an LPDA-1 Nontailed Telecommunication Link	23-10
23-5.	LPDA-2 Nontailed, Nonchannelized Link	23-12
23-6.	Example: Defining an LPDA-2 Nontailed, Nonchannelized Link	23-12
23-7.	LPDA-2 Tailed, Nonchannelized Link	23-13
23-8.	Example: Defining an LPDA-2 Tailed, Nonchannelized Link	23-13
23-9.	Full Data Multiplex Configuration	23-14
23-10.	Example: Defining a Full Data Multiplex Configuration	23-15
23-11.	Multiple Local Modems	23-17
23-12.	Example: Defining Local Modem Addresses	23-17
A-1.	Sample Network Connections	A-3
A-2.	NCP A03 Sample Generation Definition	A-7
A-3.	NCP A04 Sample Generation Definition	A-39
A-4.	NCP A31 Sample Generation Definition	A-82
A-5.	NCP B31 Sample Generation Definition	A-128
A-6.	NCP B75 Sample Generation Definition	A-155
A-7.	NCP C04 Sample Generation Definition	A-191
B-1.	Host A17 Sample IFWNET Generated Table	B-1
B-2.	NCP A03 Sample NDF-Generated Table	B-2

---

## Tables

0-1.	Sources of Information by Task for NCP V7R8	xxxiv
3-1.	Usage Tier Definition	3-10
3-2.	Usage Tiers for the 3746 Model 900	3-11
5-1.	MONLINK Values for ESCON Links	5-18
6-1.	Token-Ring Logical Subarea and Peripheral Connections	6-33
7-1.	Values Coded with the Subaddress Method	7-27
7-2.	Values Coded with the Number Method	7-27
7-3.	ISDN D-Channel Defined	7-28
7-4.	ISDN B-Channel Defined	7-29
7-5.	ISDN B-Channel Defined Based on Incoming Call Setup	7-29
7-6.	ISDN B-Channel to Another DTE	7-30
7-7.	ISDN B-Channel to the Same DTE	7-31
8-1.	Segment Sizes used by NCP	8-17
8-2.	Accumulated Transmission Time By Line Type and Speed	8-18
8-3.	Minimum Link Capacity by Line Type and Speed	8-19
12-1.	Format-2 XID and TGN Exchanges	12-19
12-2.	How NCP Determines Segment Size	12-24
15-1.	Internet Address Structure	15-5
16-1.	Values for FRELAY on the GROUP Definition Statement	16-10
21-1.	Summary of EPSA-Related Keywords for the GROUP and LINE Definition Statements	21-5
23-1.	Modem Models and LPDA Modes and Configurations Supported	23-6
A-1.	Functions Included in Sample Definitions	A-2





---

## Notices

References in this publication to IBM products, programs, or services do not imply that IBM intends to make these available in all countries in which IBM operates. Any reference to an IBM product, program, or service is not intended to state or imply that only IBM's product, program, or service may be used. Any functionally equivalent product, program, or service that does not infringe any of IBM's intellectual property rights may be used instead of the IBM product, program, or service. Evaluation and verification of operation in conjunction with other products, except those expressly designated by IBM, are the user's responsibility.

IBM may have patents or pending patent applications covering subject matter in this document. The furnishing of this document does not give you any license to these patents. You can send license inquiries, in writing, to:

IBM Director of Licensing  
IBM Corporation  
North Castle Drive  
Armonk, NY 10504-1785  
U.S.A.

Licensees of this program who wish to have information about it for the purpose of enabling: (i) the exchange of information between independently created programs and other programs (including this one) and (ii) the mutual use of the information which has been exchanged, should contact:

Licensing  
IBM Corporation  
PO Box 12195  
3039 Cornwallis  
Research Triangle Park, NC 27709-2195  
U.S.A

Such information may be available, subject to appropriate terms and conditions, including in some cases, payment of a fee.

For license inquiries regarding double-byte (DBCS) information, contact the IBM Intellectual Property Department in your country or send inquiries, in writing, to:

IBM World Trade Asia Corporation  
Licensing  
2-31 Roppongi 3-chome, Minato-ku  
Tokyo 106, Japan

The licensed program described in this document and all licensed material available for it are provided by IBM under terms of the IBM Customer Agreement, IBM International Program License Agreement, or any equivalent agreement between us.

The following paragraph does not apply to the United Kingdom or any other country where such provisions are inconsistent with local law:

INTERNATIONAL BUSINESS MACHINES CORPORATION PROVIDES THIS PUBLICATION "AS IS" WITHOUT WARRANTY OF ANY KIND, EITHER EXPRESS OR

IMPLIED, INCLUDING, BUT NOT LIMITED TO, THE IMPLIED WARRANTIES OF NON-INFRINGEMENT, MERCHANTABILITY OR FITNESS FOR A PARTICULAR PURPOSE. Some states do not allow disclaimer of express or implied warranties in certain transactions, therefore, this statement may not apply to you.

This information could include technical inaccuracies or typographical errors. Changes are periodically made to the information herein; these changes will be incorporated in new editions of the publication. IBM may make improvements and/or changes in the product(s) and/or the program(s) described in this publication at any time without notice.

---

## Notice to Users of Online Versions of This Book

For online versions of this book, you are authorized to:

- Copy, modify, and print the documentation contained on the media, for use within your enterprise, provided you reproduce the copyright notice, all warning statements, and other required statements on each copy or partial copy.
- Transfer the original unaltered copy of the documentation when you transfer the related IBM product (which may be either machines you own, or programs, if the program's license terms permit a transfer). You must, at the same time, destroy all other copies of the documentation.

You are responsible for payment of any taxes, including personal property taxes, resulting from this authorization.

THERE ARE NO WARRANTIES, EXPRESS OR IMPLIED, INCLUDING THE WARRANTIES OF MERCHANTABILITY AND FITNESS FOR A PARTICULAR PURPOSE.

Some jurisdictions do not allow the exclusion of implied warranties, so the above exclusion may not apply to you.

Your failure to comply with the terms above terminates this authorization. Upon termination, you must destroy your machine-readable documentation.

---

## Trademarks

The following terms are trademarks of the IBM Corporation in the United States or other countries or both:

ACF/VTAM	IBM	Personal System/2
Advanced Peer-to-Peer Networking	Library Reader	PS/2
AIX	LPDA	SecureWay
APPN	MVS	SELECTRIC
BookManager	MVS/ESA	SP
CICS	NETCENTER	System/370
eNetwork	NetView	Virtual Machine/Enterprise Systems Architecture
Enterprise Systems Connection Architecture	NTune	VM/ESA
ESA/370	NTuneMON	VSE/ESA
ESA/390	NTuneNCP	VTAM
ESCON	Nways	
Hardware Configuration Definition	OS/2	
	OS/390	

Other company, product, and service names may be trademarks or service marks of others.



---

## About This Book

This book helps you learn about defining resources to Advanced Communications Function for Network Control Program (NCP) and Emulation Program (EP). It contains a general description of the functions, definition statements, and keywords used to define resources to NCP and EP.

---

## Who Should Use This Book

This book is for system analysts, system programmers, system engineers, and field support personnel responsible for defining an NCP or EP for an IBM 3745 Communication Controller. In addition to a complete set of specifications for the resources in your network, you need a good understanding of the following:

- Systems Network Architecture (SNA) and the functions NCP provides in an SNA network<sup>1</sup>
- The hardware and software requirements for NCP<sup>2</sup>
- Your network configuration.

---

## How to Use This Book

This book gives you the information you need to select the appropriate definition statements and keywords to define your network resources to NCP and EP. It is designed to be used in conjunction with the *NCP, SSP, and EP Resource Definition Reference*, which contains detailed explanations of how to code those definition statements and keywords.

Examine your configuration to determine:

- The physical and operational characteristics of your controller
- The resources in your network
- The functions of your network
- The subareas supported in your network.

Once you know what you want to define, read the parts of the book that are relevant to your configuration.

“Part 1. Producing an NCP” describes NCP definition statements and their keywords that you use to describe your specific controller and network environment. It also presents an overview of the utilities and aids that are available for generating your NCP definition. See “Special Considerations for Using This Book” on page 1-3 for information about line protocol and coding conventions.

Once you understand the fundamentals described in Part 1, read “Part 2. Defining NCP Resources.” It describes the definition of 370 I/O channel attachments, ESCON links, link-attached devices, Token Rings, ISDN resources, type 2.1 nodes, and block handlers. This part also describes dynamic reconfiguration of SDLC devices, peripheral channel links, how to define the physical connections and

---

<sup>1</sup> Refer to *Systems Network Architecture Technical Overview* for more information.

<sup>2</sup> Refer to *Planning for NetView, NCP, and VTAM* for more information.

## About This Book

logical paths between the NCP you are defining and other NCPs in the network, and how to define a gateway NCP and a gateway SSCP to connect two networks.

If you want to define connections between multiple networks, read Chapter 15, “Internet Resources” and Chapter 16, “Frame-Relay Resources,” which tell you how to define the interconnection of a network with the Transmission Control Protocol/Internet Protocol (TCP/IP) environment and how to define frame-relay resources that use frame-relay terminating equipment (FRTE) and frame-relay frame handler (FRFH) functions.

“Part 3. Defining Pre-SNA NCP Resources” tells you how to define pre-SNA NCP resources such as MTA terminals and teletypewriter terminals.

“Part 4. Defining Emulation Program Resources” tells you how to define resources for using either Partitioned Emulation Programming (PEP) or EP standalone (EPSA).

To learn how to use diagnostic aids, monitor network performance, and recover from network failures, read “Part 5. Defining Diagnostic Aids and Network Management Facilities.”

In Appendix A, there are several complete generation definitions you can refer to as you code your generation definition. These samples show common configurations. You might need different coding for your network. Also, at the end of many sections, there are examples describing individual functions.

In Appendix B, you will find tables that can be given to NETDA/2 V1R3 as inputs. They can be used to add links or update topology characteristics of the links and NCPs in NETDA/2s network input object.

---

## Terms Used in This Book

### **MVS, VM, and VSE**

The term *MVS* means the MVS/ESA and OS/390 systems. The term *VM* means the VM/ESA system in the CMS environment. The term *VSE* means the VSE/ESA operating system. If information is applicable to only one system, the specific system name is used.

### **Virtual Telecommunications Access Method (VTAM)**

The term *VTAM* means either VTAM or OS/390 SNA Services, in other words, any of the following:

- VTAM for MVS/ESA, VM/ESA, or VSE/ESA
- The SNA Services feature of eNetwork Communications Server for OS/390
- The SNA Services feature of SecureWay Communications Server for OS/390

### **IBM TCP/IP**

The term *IBM TCP/IP* means either IBM TCP/IP or OS/390 IP Services, in other words, any of the following:

- IBM TCP/IP for MVS/ESA, VM/ESA, or VSE/ESA
- The IP Services feature of eNetwork Communications Server for OS/390
- The IP Services feature of SecureWay Communications Server for OS/390

## Emulation

The terms *emulation mode* and *EP* generally refer to both forms of emulation: Partitioned Emulation Programming (PEP) and Emulation Program standalone (EPSA). When *emulation mode* is used in an obvious PEP context or in an obvious EPSA context, it refers only to PEP or only to EPSA.

## Port and Channel Used with LPDA

In discussions concerning Link Problem Determination Aid (LPDA) for multiport and data multiplex mode (DMPX) modems, the terms *port* and *channel* are synonymous. Although *port* is the more commonly used term, *channel* can be used in sections describing LPDA.

## IBM Special Products or User-Written Code

This book sometimes refers to *IBM special products or user written code*. IBM special products include Network Terminal Option (NTO), Network Routing Facility (NRF), and X.25 NCP Packet Switching Interface (NPSI).

## IBM 3745 Communication Controller Model Numbers

In this book, the term *IBM 3745 Communication Controller* refers to all IBM 3745 models. When particular models are discussed, the appropriate model numbers are specified. Model numbers include IBM 3745-130, 3745-150, 3745-160, 3745-170, 3745-17A, 3745-210, 3745-21A, 3745-310, 3745-31A, 3745-410, 3745-41A, 3745-610, and 3745-61A.

## Ethernet-Type LAN

The term *Ethernet-type LAN* means a local area network (LAN) that uses either the Ethernet Version 2 or IEEE 802.3 protocol.

## CSS and 3746 Model 900

The term *connectivity subsystem (CSS)* refers to the 3746 Model 900 connectivity subsystem, an expansion frame that extends the connectivity and enhances the performance of the IBM 3745 Communication Controller.

## Token Ring

NCP can connect to an IBM Token-Ring Network using the NCP/Token-Ring interconnection (NTRI) or the 3746 Model 900 connectivity subsystem attachment. This book uses the term *Token Ring* to refer to either type of connection.

## Frame Relay

To support frame-relay networks, NCP can use a transmission subsystem (TSS) or high-performance transmission subsystem (HPTSS) adapter on the 3745, or NCP can use a communication line processor (CLP) adapter on the 3746 Model 900 connectivity subsystem. In addition, NTRI frame handler connections use type 1 and type 2 Token-Ring interface couplers (TICs). Unless otherwise stated, this book uses the term *frame relay* when referring to a 3745 or a 3746 Model 900 connection.

### **NTuneMON and its Tuning Feature NTuneNCP**

NTuneMON is a program that runs with NetView and monitors NCPs that were activated by the VTAM on the host where NTuneMON is running. If you have the NTuneMON tuning feature, NTuneNCP, you can also tune NCP resources. For more information on NTuneMON and its tuning feature, NTuneNCP, see *NTuneMON User's Guide*.

### **X.25 Outboard Data Link Control (ODLC)**

Starting with NCP V7R4, NCP running in a 3746 Model 900 communication subsystem can connect to X.25 SNA devices through a public switched data network (PSDN) without the need for the X.25 NCP Packet Switching Interface (NPSI) Program Product. Only SNA Qualified Logical Link Control (QLLC) Data Terminal Equipment (DTE) connections are supported by this function. Non-SNA devices will still need the NPSI Program Product. X.25 ODLC support by NCP V7R4 or a later release and X.25 NPSI support by NPSI V3R8 or later can coexist in the same 3745 and 3746 Model 900 combination.

For SNA, X.25 ODLC support was integrated into NCP V7R4 and provides increased performance because the lower Data Link Control (DLC) functions are contained in the 3746 Model 900. Information concerning X.25 ODLC support has been incorporated into the *NCP Version 7 and X.25 NPSI Version 3 Planning and Installation* and *NCP Version 7 and X.25 NPSI Version 3 Diagnosis, Customization, and Tuning* manuals, which are now part of the NCP Library.

### **Integrated Services Digital Network (ISDN)**

Integrated services digital network (ISDN) is a digital end-to-end telecommunication network that supports multiple services including, but not limited to, voice and data. ISDNs are used in public and private network architectures. Starting with NCP V7R5, the 3746 Model 900 connectivity subsystem (CSS) supports an interface into existing ISDN environments for SNA sessions routed through the CSS.

### **NCP V7R2, NCP V7R3, NCP V7R4, NCP V7R5, NCP V7R6, NCP V7R7, NCP V7R8**

In this book, unless otherwise specified, the term *NCP V7R2* refers to NCP Version 7 Release 2, *NCP V7R3* refers to NCP Version 7 Release 3, *NCP V7R4* refers to NCP Version 7 Release 4, *NCP V7R5* refers to NCP Version 7 Release 5, *NCP V7R6* refers to NCP Version 7 Release 6, *NCP V7R7* refers to NCP Version 7 Release 7, and *NCP V7R8* refers to NCP Version 7 Release 8 with or without the optional NCP feature for 3746 Model 900 connectivity subsystem support. To use this feature, you must have the 3746 Model 900 installed in your controller.

### **RIP (Routing Information Protocol)**

RIP-1 means RIP Version 1, RIP-2 means RIP Version 2, and RIP means either RIP-1 or RIP-2.



## Symbols Used in This Book

Figure 0-1 shows the networking symbols used in the illustrations that appear throughout this book.

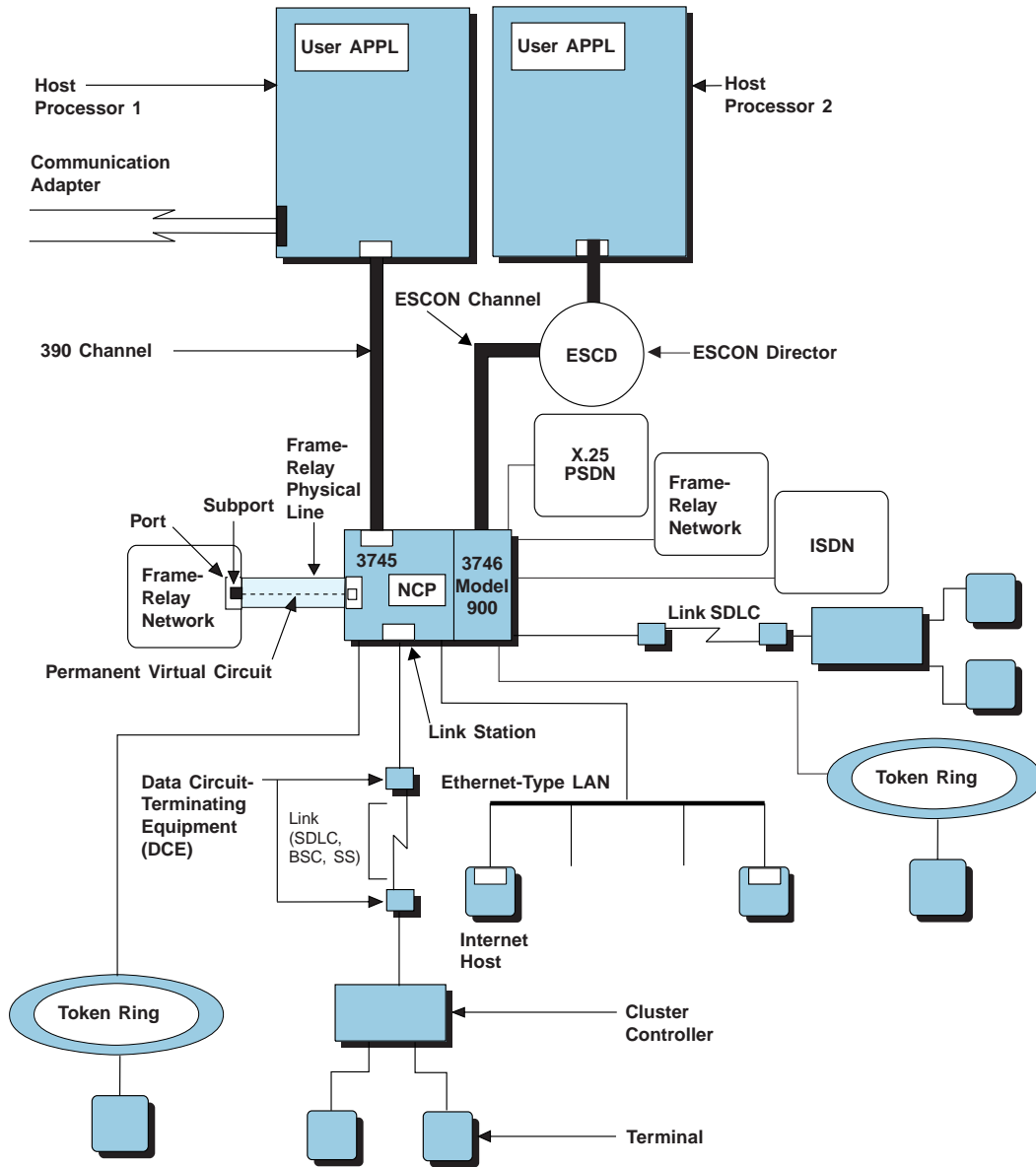

Figure 0-1. Symbols Used in Illustrations

## What Is New in This Book

This edition contains information on the following new NCP and SSP functions, as well as editorial and technical changes. New or changed information is identified in this book by a vertical line (|) in the left margin.

### Logical Line Pool Sharing for TIC3 Connections

You can now code the PHYPORT keyword on 3746 Model 900 Token-Ring logical peripheral GROUP statements. See “Unassigned Logical Line Pools” on page 6-24.

### Using 3746 Model 900 TIC3 Connection Balancing

You can now define the BALANCE keyword on 3746 Model 900 Token-Ring physical GROUP and LINE definition statements. See the description of the BALANCE keyword on page 6-8.

### Using Enhanced Control of the Dynamic Working Window for 3745 Token Ring

You can now control the amount by which the working window is decreased when frame loss or congestion occurs for 3745 Token-Ring Ring resources by coding the second and third suboperands (dw and dwc) of the DYNWIND keyword. See the description of the DYNWIND keyword on page 6-43.

### Specifying a Minimum Working-Window Value for 3745 Frame Relay

The *mww* suboperand is added to the DYNWIND keyword to provide a minimum user-specified working window value for frame relay. See the description of the DYNWIND keyword on page 16-15.

### Using 3746 Model 900 Frame-Relay BAN Connection Balancing

You can now define the BALANCE keyword on 3746 Model 900 Frame-Relay DLCI statements. See BALANCE keyword on the DLCI statement on page 16-14.

### Using Enhanced Control of Adaptive Session Pacing

The new ADPLIMIT keyword enables you to limit the maximum window size that NCP permits on an adaptively paced session. See “Defining Session Pacing” on page 24-6.

### Detecting a Hung Transmission Group (TG)

The new TGTIMER keyword provides enhanced hung-TG detection. See “Monitoring Transmission Group Performance” on page 23-18.

### Specifying LRC8 Error Checking

LRC8 error checking is available for BSC USASCII lines running in transparent mode. See the description of the FEATURE keyword on page 20-5.

## Ignoring Data from an Undefined 3270 BSC Device

You can tell NCP to ignore data from an undefined 3270 BSC device. See the new function of the FEATURE keyword on page 5-28.

## Taking over an EP Line from Another Host

The new TAKEOVER keyword on the LINE statement enables you to force take-over of EP line from another host. See the description of the TAKEOVER keyword on page 21-12.

## Setting the V.25 Dial Timer

A new keyword enables you to set the V.25 dial timer, formerly a fixed 2-minute timer, for EP lines. See the description of the V25DIAL keyword on page 20-7.

## Defining up to 32 ESCON Stations

The maximum number of ESCON stations has increased from 16 to 32. For example, see the description of the ADDR keyword on page 15-23.

## Generating a Minimum-Size Remote Load Module

The new MINILOAD keyword facilitates the generating of a minimum-size remote load module. See the description of the MINILOAD keyword on page 2-6.

---

## Where to Find More Information

A good place to start any task regarding NCP, SSP, or EP is the *NCP V7R8, SSP V4R8, and EP R14 Library Directory*. This directory introduces the enhancements for the current release and shows where these enhancements are described in the NCP library. It gives you an overview of NCP, SSP, and EP and directs you to information on a variety of tasks related to these programs. When you are using the book online, you can use *hypertext links*<sup>3</sup> to move directly from task and enhancement descriptions to the appropriate chapters of other books in the library.

## Information for NCP Tasks

The books in the NCP, SSP, and EP library are listed here according to task, along with closely related books and tools you may find helpful. See “Bibliography” on page X-35 for a brief summary of each book in the NCP, SSP, and EP library and listings of related publications.

---

<sup>3</sup> A *hypertext link* is a pointer from a location in an online book to another location in the same book or another book. By selecting highlighted information, such as a message number, you can move quickly to related information and, if desired, back again.

Table 0-1. Sources of Information by Task for NCP V7R8

Order No.	Title	Hardcopy	Softcopy
<b>Planning</b>			
SC31-8063	<i>Planning for NetView, NCP, and VTAM</i>		■
SC31-8062	<i>Planning for Integrated Networks</i>		■
SC30-4025	<i>NCP V7R8, SSP V4R8, and EP R14 Library Directory</i>	■	■
SC30-3470	<i>NCP Version 7 and X.25 NPSI Version 3 Planning and Installation</i>	■	■
<b>Installation and Resource Definition</b>			
SC31-6221	<i>NCP, SSP, and EP Generation and Loading Guide</i>	■	■
SC30-4024	<i>NCP V7R8 Migration Guide</i>	■	■
SC31-6223	<i>NCP, SSP, and EP Resource Definition Guide</i>	■	■
SC31-6224	<i>NCP, SSP, and EP Resource Definition Reference</i>	■	■
<b>Customization</b>			
LY43-0031	<i>NCP and SSP Customization Guide</i>		■
LY43-0032	<i>NCP and SSP Customization Reference</i>	■	■
<b>Operation</b>			
SC31-6222	<i>NCP, SSP, and EP Messages and Codes</i>	■	■
<b>Diagnosis</b>			
LY43-0033	<i>NCP, SSP, and EP Diagnosis Guide</i>	■	■
LY43-0037	<i>NCP, SSP, and EP Trace Analysis Handbook</i>	■	■
LY43-0029	<i>NCP and EP Reference</i>	■	■
LY43-0030	<i>NCP and EP Reference Summary and Data Areas</i>	■	■
LY30-5610	<i>NCP Version 7 and X.25 NPSI Version 3 Diagnosis, Customization, and Tuning</i>	■	■
<b>Monitoring and Tuning</b>			
SC31-6266	<i>NTuneMON User's Guide</i>	■	■
LY43-0039	<i>NTuneNCP Feature Reference</i>	■	■

Those publications available as softcopy books have cross-document search and hypertext links for speedy, online information retrieval. These softcopy books are grouped together on an electronic bookshelf as part of the *ACF/NCP, ACF/SSP, EP, NPSI, and NTuneMON Softcopy Collection Kit*, LK2T-0414, on compact disc read-only memory (CD-ROM).

You can view and search these softcopy books by using BookManager READ products or by using the IBM Library Reader product included on the CD-ROM. For more information on CD-ROMs and softcopy books, see the *IBM Online Libraries: Softcopy Collection Kit User's Guide*, the BookManager READ documentation, or the BookManager home page at:

<http://booksrv2.ra1eigh.ibm.com>

You can also access unlicensed softcopy NCP publications in Acrobat or BookManager formats from the NCP home page at:

|

<http://www.networking.ibm.com/ncp>



---

## Part 1. Producing an NCP

<b>Chapter 1. Defining Your NCP Configuration</b> . . . . .	1-1
What Kind of Network Are You Defining? . . . . .	1-1
Special Considerations for Using This Book . . . . .	1-3
Line Protocols . . . . .	1-3
Coding Conventions . . . . .	1-3
How You Define Resources to NCP . . . . .	1-4
Generation Process Control Definition Statement . . . . .	1-5
System Definition Statements . . . . .	1-5
Configuration Definition Statements . . . . .	1-5
Network Configuration Definition Statements . . . . .	1-6
NCP Router Definition Statements . . . . .	1-6
SNI Nonnative Network Definition Statements . . . . .	1-7
Block Handler Definition Statements . . . . .	1-7
Generation Delimiter Definition Statement . . . . .	1-7
Coding Lower Level Keywords on Higher Level Definition Statements . . . . .	1-7
Definition Statement Usage and Sequence for NCP Generation . . . . .	1-8
OPTIONS . . . . .	1-8
PCCU . . . . .	1-9
BUILD . . . . .	1-9
SYSCNTRL . . . . .	1-9
NCPNAU . . . . .	1-9
GWNAU . . . . .	1-10
HOST . . . . .	1-10
IDLIST . . . . .	1-11
LUPPOOL . . . . .	1-11
LUDRPOOL . . . . .	1-11
PUDRPOOL . . . . .	1-12
PATH . . . . .	1-12
SDLCST . . . . .	1-12
DIALSET . . . . .	1-13
MTALCST . . . . .	1-14
MTALIST . . . . .	1-14
MTAPOLL . . . . .	1-14
MTATABL . . . . .	1-14
SWMMT . . . . .	1-15
GROUP . . . . .	1-15
LINE . . . . .	1-16
DLCI . . . . .	1-17
SERVICE . . . . .	1-17
CLUSTER . . . . .	1-18
TERMINAL . . . . .	1-18
COMP . . . . .	1-19
PU . . . . .	1-20
IPHOST . . . . .	1-21
LU . . . . .	1-21
FRSESET . . . . .	1-21
ENDAUTO . . . . .	1-22
IPOWNER . . . . .	1-22
IPLOCAL . . . . .	1-22
IPROUTE . . . . .	1-22

NETWORK	1-22
GWNAU	1-23
PATH	1-23
STARTBH	1-24
EDIT	1-24
DATETIME	1-24
UBHR	1-24
REMOVCTL	1-25
ENDBH	1-25
BHSET	1-25
GENEND	1-25
Definition Statements for Dynamic Reconfiguration	1-25
ADD	1-25
DELETE	1-26
<b>Chapter 2. Generating an NCP Load Module</b>	2-1
NDF-Generated Definition File	2-1
Reusable NEWDEFN File	2-3
FASTRUN Keyword	2-5
Defining the NCP Environment	2-5
Dynamically Created Control Blocks	2-10
Automatic Line Generation	2-12
Autocopy Function	2-12
Autoline Function	2-16
Migration Aid Function	2-18
<b>Chapter 3. Defining Your Communication Controller</b>	3-1
Defining an IBM 3745 Communication Controller	3-1
Fallback and Switchback	3-2
Fallback for NCP	3-3
Fallback for EP (PEP only)	3-5
Switchback	3-5
Fallback and Switchback for IBM Special Products or User-Written Code	3-6
3746 Model 900 Connectivity Subsystem	3-6
Shared 3746 Model 900 Resources between Two NCPs	3-7
Shared 3746 Model 900 Resources between an NCP and 3746 Model 900	3-7
Fallback and Switchback for 3746 Model 900 Resources	3-8
Usage Tiers	3-9
Usage Tiers for the IBM 3745 Communication Controller	3-10
Usage Tiers for the 3746 Model 900	3-11



---

## Chapter 1. Defining Your NCP Configuration

Use this book to define your network configuration for Network Control Program (NCP) and Emulation Program (EP). When you define your network configuration, you define the relationship of the resources in the network to NCP. This relationship refers to the physical and operational characteristics of the resources that affect the way they work with NCP. Examples of these resource characteristics are addresses, types, and speeds, as well as transmission protocols, methods of handling data, and special provisions for backup and recovery. Resources attached to NCP can have many possible physical and operational characteristics. Therefore, you must thoroughly understand your network configuration and your processing goals before you begin to define these resources to NCP.

---

### What Kind of Network Are You Defining?

Before defining your NCP, it is important to determine which network resources are part of your configuration and must be defined to NCP. The following series of questions will help you evaluate the required functions and characteristics of your network. Read through these questions, and list the answers as you go. The answers you provide may suggest other questions to be answered about your particular resources.

- What operating system are you using?
  - MVS
  - VM
  - VSE
- What types of line protocol are used by the devices attached to your NCP?
  - Binary synchronous communication (BSC)
  - Ethernet-type LAN
  - Frame relay
  - IBM special products or user-written code
  - Synchronous Data Link Control (SDLC)
  - Start-stop
  - Token Ring
- Do you need to provide routing support for Internet Protocol (IP) datagrams?
- Does your NCP communicate with other subareas by means of a frame-relay network?
- Which diagnostic aids do you want to include?
- Do you need to support independent logical units (type 2.1 physical units)?
- Does your NCP attach to type 2.1 peripheral nodes?
- How are you defining the routes between subareas?
- Is your NCP connected to an IBM 9221 host processor?
- What access methods will your NCP communicate with?
- Can your NCP communicate with any channel-attached host processors?
- Is your NCP link-attached to another NCP?
- Do you have any switched links connected to your NCP?

## Defining Your Network Type

- Are you using Enterprise Systems Connection Architecture channels and the 3746 Model 900 connectivity subsystem?
- Are you defining Token-Ring resources to your NCP?
- Are you defining an NCP that includes the SNA network interconnection (SNI) function to join two or more interconnected networks?
- What backup, recovery, and performance features do you need?
- Are you using extended subarea addressing?
- Are you including IBM special products (such as the Network Routing Facility (NRF) or the Network Terminal Option (NTO)) or user-written code to add special device support and functions to your NCP?
- Are you using or providing frame-relay network resources or functions?
- Are you using ISDN resources?
- Will your NCP use casual connection to communicate with another NCP?
- Are you using IBM 3174 group poll?
- Are you using parallel transmission groups?
- What types of Token-Ring interface couplers are you using?
- Do you have any IBM 786x modems?
- Do you have any V.25 bis modems?
- Are you including the dynamic reconfiguration function for any SDLC devices attached to your NCP?
- Are you including block handlers for any BSC or start-stop devices attached to your NCP?
- Do you have any devices attached to your NCP that you want to be able to operate in emulation mode in the PEP environment of NCP?
- Do you have any switched, multiple-terminal-access (MTA) links connected to your NCP?
- Do you have any clustered IBM 3270 BSC stations attached to your NCP?
- Do you have any teletypewriter exchange service (TWX) or World Trade Teletypewriter (WTTY) devices attached to your NCP?

The specific characteristics of your network determine not only which definition statements you code, but also which keywords on each of the definition statements you need to define. You should be familiar with your network before you try to determine which of these definition statements and keywords to code.

You might want to modify or customize your NCP to add support for certain stations or provide support for other stations that are not currently supported by IBM-supplied programs. *NCP and SSP Customization Guide* and *NCP and SSP Customization Reference* provide information to help you customize your NCP. These books also contain information to help you write routines that interface with NCP so you can use programmed Systems Network Architecture (SNA) resources that reside in your communication controller.

---

## Special Considerations for Using This Book

As you use this book, you should be aware of the following line protocols and coding conventions.

### Line Protocols

NCP controls the flow of data through a network between the host processor and link-attached devices. This group of devices includes:

- Keyboard-printer terminals
- Clustered stations with, for example, displays and printers
- Distributed processing systems
- Remote job entry stations
- Other communication controllers.

Each link-attached device uses one of three line protocols to communicate with NCP: SDLC, BSC, or start-stop communication. NCP also supports attachments to other networks using the Institute of Electrical and Electronic Engineers (IEEE) 802.5 protocol for Token-Ring local area networks (LANs), IEEE 802.3 or Ethernet Version 2 protocol for Ethernet-type LANs, and CCITT- or ANSI-standard frame-relay protocol for frame-relay and ISDN networks.

In this book, a device attached to an SDLC link is called an SDLC device, a device attached to a BSC link is called a BSC device, and a device attached to a start-stop link is called a start-stop device. A device is not considered SDLC, BSC, or start-stop because of its design or purpose. For example, an IBM 3174 Control Unit can be attached to NCP by either an SDLC link or a BSC link. When it is attached to an SDLC link, it is defined in this book as an SDLC device; when attached to a BSC link, it is called a BSC device. Some devices, such as an IBM 1050 Data Communication System device, can use only the start-stop line protocol to communicate with NCP, and therefore are considered start-stop devices.

SDLC devices are Systems Network Architecture (SNA) devices. BSC and start-stop devices are non-SNA devices. BSC 3270 devices can operate in an SNA network with VTAM. Other non-SNA devices can operate in an SNA VTAM network through IBM special products such as the Network Terminal Option (NTO).

### Coding Conventions

The sample definition statement and keyword coding used in this book is not shown in standard assembler language format. Continuation characters are omitted and the definition statements and keywords do not start in columns 10 and 16, respectively. Lengthy comments can be inserted in coding samples to explain the functions of individual keywords. These extended comments are for explanation only and will probably not assemble correctly if included in your system generation. When you code your NCP generation definition, be sure to conform to standard assembler language conventions. For more information about how to code the system generation, see *NCP, SSP, and EP Resource Definition Reference*. When a paragraph applies only to certain functions, a boldface introductory phrase indicates the restriction. For example, in Chapter 6, "Token-Ring Resources," the phrase **3746 Model 900:** indicates information that applies only to 3746 Model 900 connectivity subsystem resources. When an entire section applies only to certain functions, the first sentence in the section indicates the restriction.

## Defining Resources to NCP

You do not have to code every definition statement and keyword discussed. Some of the definition statements and keywords are required regardless of your configuration. Other definition statements and keywords are required for specific configurations. See “Definition Statement Usage and Sequence for NCP Generation” on page 1-8 for information about definition statements that are required for every configuration, and definition statements that are required only for specific resources. Read *NCP, SSP, and EP Resource Definition Reference* for information on which keywords are required.

---

## How You Define Resources to NCP

You define resources to NCP by coding a generation definition that consists of definition statements. The definition statements describing each resource must appear in certain positions in the generation definition. Be sure that you define your resources in the following order:

1. Start-stop PEP line groups
2. Start-stop NCP line groups
3. BSC PEP line groups
4. BSC NCP line groups
5. Line groups defined as SDLC, including the following (these resources can be defined in any order):
  - SDLC telecommunication links
  - Network Terminal Option (NTO) resources
  - NetView Performance Monitor (NPM) resources, with definitions for both NPM and Network Session Accounting (NSA)
  - Network Routing Facility (NRF) resources
  - X.25 resources
  - X.25 SNA interconnection (XI) resources
  - X.21 resources
  - Frame-relay resources
  - ISDN resources
6. 3746 Model 900 and NTRI Token-Ring resources
7. Ethernet-type LAN resources
8. 370 I/O and ESCON channel adapter line groups
9. User line groups
10. SNA network interconnection (SNI) nonnative resources.

Definition statements contain many keywords. The values you specify on these keywords describe the relationship of the resources in the network to NCP. NCP uses eight types of definition statements:

- Generation process control
- System
- Configuration
- Network configuration
- Router
- SNI nonnative network
- Block handler
- Generation delimiter.

## Generation Process Control Definition Statement

The generation process control definition statement creates a new generation definition or selectively controls the generation procedure for diagnostic purposes. This definition statement activates and deactivates traces, such as parameter traces, data traces, and procedure traces. It also selectively dumps instances of the major data structures used by the generation process, and runs the generation procedure in FASTRUN mode to check for input errors without creating object modules.

OPTIONS is the only generation process control definition statement.

## System Definition Statements

System definition statements provide information about the communication controller where NCP resides, functional options you choose for your NCP, and generation procedure characteristics. For example, the system definition statements specify the following information:

- The NCP release you are generating
- The size of the buffers your NCP contains
- The number and positions of channel adapters installed in the communication controller
- Optional diagnostic aids, such as an address trace, that you want to include in your NCP
- Optional dynamic control functions, such as dynamic reconfiguration, that you want to include in your NCP.

The system definition statements are:

PCCU	NCPNAU
BUILD	GWNAU
SYSCNTRL	

## Configuration Definition Statements

Configuration definition statements provide information necessary to build the NCP tables. These tables control the flow of data between the communication controller and its link-attached devices, and between the controller and any channel-attached host processors. For example, the configuration definition statements specify the following information:

- The average block size and buffer unit size used by the host processor access method
- Lists of valid identification sequences for BSC devices or teletypewriter exchange service (TWX) terminals that dial in over the switched network
- The explicit routes and adjacent subareas used to send data to destination subareas in the network

The configuration definition statements are:

HOST	PUDRPOOL	MTALIST
IDLIST	SDLCST	MTAPOLL
LUPOOL	DIALSET	MTATABL
LUDRPOOL	MTALCST	SWMMT

### Network Configuration Definition Statements

Network configuration definition statements specify characteristics and functions for the following resources attached to NCP:

- SNA physical units and logical units
- Telecommunication links and link groups
- Cluster controllers
- Terminals
- Components of terminals.

Some of the characteristics and functions defined are:

- The speed at which the links connected to NCP operate
- Physical units and logical units of a peripheral host node (type 2 physical unit)
- Physical units of a subarea host node (type 5 physical unit)
- The type of clocking used by the links connected to NCP
- The transmission code used by the BSC and start-stop links connected to NCP
- The addresses of the links, physical units, logical units, terminals, and components of terminals attached to NCP
- The maximum amount of data that the physical units attached to NCP can receive from NCP in one data transfer.

The network configuration definition statements are:

GROUP	COMP
LINE	PU
SERVICE	LU
CLUSTER	TERMINAL
ENDAUTO	

### NCP Router Definition Statements

NCP router definition statements define SNA, Internet Protocol (IP), and frame-relay routing functions. These definition statements provide routing, address, frame, device, and buffer management information.

**SNA:** Use the SNA router definition statement to route subarea and peripheral traffic. The SNA router definition statement is:

PATH

**Internet Protocol:** Use the internet router definition statements to route IP datagrams through an internet network. The internet router definition statements are:

IPOST	IROUTE
IPLOCAL	IPOWNER

**Frame Relay:** Use the frame-relay router definition statement to route (or *switch*) frames through a frame-relay network. The frame-relay router definition statement is:

FRSESET

## SNI Nonnative Network Definition Statements

SNI nonnative network definition statements define the characteristics of independently defined networks joined by a gateway NCP and a gateway system services control point (SSCP).

The SNI nonnative network definition statements are:

```

GWNAU      PATH
NETWORK

```

## Block Handler Definition Statements

Use the block handler definition statements only if you attach BSC or start-stop devices to your NCP. These statements provide information that describes the optional processing that NCP can perform on a block of data before sending or after receiving the block. The block handler can change data in either a transmitted or a received block. For example, the block handler definition statements specify the following information:

- Block handling routines that perform specific processing functions, such as inserting the date and time into blocks of data, and correcting text incorrectly entered from a device
- Block handlers and sets of block handlers that consist of one or more block handling routines.

The block handler definition statements are:

```

STARTBH    REMOVCTL
EDIT       ENDBH
DATETIME   BHSET
UBHR

```

## Generation Delimiter Definition Statement

The generation delimiter definition statement ends the definition statements in the NCP generation definition. It also provides information about the entry points and library member names of user-written code you can include in your NCP.

GENEND is the only generation delimiter definition statement.

---

## Coding Lower Level Keywords on Higher Level Definition Statements

Because definition statements appear in a generation definition in a hierarchical format, high-level definition statements are usually followed by low-level definition statements. Certain keywords that belong to a lower level definition statement can be coded on a higher level definition statement to save coding effort. For example, five characteristics common to 15 terminals on a line can be specified once on the LINE definition statement rather than on each of the 15 TERMINAL definition statements; therefore, five keywords are coded instead of 75.

In this book, keywords are described on the lowest level definition statement on which they can appear; however, coding samples often show lower level keywords coded on higher level definition statements. For information about which keywords to define on a particular definition statement, see *NCP, SSP, and EP Resource Definition Reference*.

---

### Definition Statement Usage and Sequence for NCP Generation

As noted earlier, definition statements appear in a certain order in a generation definition. The position of the definition statements and descriptions of their usage follow. They are listed in the order in which they must appear in the generation definition.

You do not have to code all of the definition statements, but you must select the appropriate definition statements depending on your controller and configuration.

To define NCP, you must code the following definition statements:

- BUILD
- SYSCNTRL
- PATH
- GROUP
- LINE
- GENEND.

### OPTIONS

**Usage:** Use the OPTIONS definition statement if you want to control processing in the generation procedure. Use OPTIONS to:

- Turn traces on and off, such as parameter traces, data traces, and procedure traces, and to selectively dump instances of the major data structures used by the generation process. You can define as many traces as you need for diagnostic purposes on the OPTIONS definition statement. For more information on using OPTIONS for diagnostic purposes, see *NCP, SSP, and EP Diagnosis Guide*.
- Run the generation procedure in FASTRUN mode to check for input errors without creating object modules. FASTRUN cannot be disabled after it is started.
- Give certain IBM special products or user-written code access to the NCP/EP definition facility (NDF) internal routines through the NDF standard attachment facility as described in "NDF-Generated Definition File" on page 2-1.
- Create a new generation definition containing the definition statements and keywords you coded, statements and keywords generated by the standard attachment facility, and definitions added by NDF. Use NEWDEFN=(YES,...) on the OPTIONS definition statement to create a new generation definition file when you define:
  - Automatic line generation
  - Ethernet-type LAN resources
  - Frame-relay resources
  - ISDN resources
  - Internet resources
  - Network Routing Facility (NRF)
  - Migration aid function
  - Token-Ring resources
  - User-written applications that modify the generation definition
  - X.25 NCP Packet Switching Interface (NPSI)
  - X.25 Outboard Data Link Control (ODLC).



- Format the output created by the automatic line generation procedure by specifying NEWDEFN.

**Position:** When specifying the use of the NDF standard attachment facility, doing a FASTRUN generation, or creating a new generation definition, OPTIONS must be first in the generation definition. Otherwise, OPTIONS can appear anywhere in the generation definition.

### PCCU

**Usage:** Required only for VTAM. Use one PCCU definition statement for each VTAM that can activate NCP. The NCP generation procedure does not use the PCCU definition statement. See *VTAM Resource Definition Reference* for a complete description of PCCU.

**Position:** Must precede the BUILD definition statement.

### BUILD

**Usage:** Required. Use the BUILD definition statement to specify a wide variety of characteristics and functions of an NCP and its relationship to the resources attached to it. Some of these characteristics and functions are:

- The hardware features of the communication controller
- Diagnostic aids
- Program generation specifications
- Network addressability (routes between subareas)
- The limits of the native network.

BUILD also helps define the characteristics of the native network if you include the SNA network interconnection function to connect two or more independent networks. For more information on interconnected networks, see Chapter 14.

**Position:** First required definition statement in the NCP generation definition. OPTIONS and one or more PCCU definition statements can precede BUILD.

### SYSCNTRL

**Usage:** Required. Use the SYSCNTRL definition statement to specify the dynamic control facilities you want for your NCP. Some of these facilities are switched network backup, display link status, change service-seeking pause, and reset device queues.

**Position:** Must follow the BUILD definition statement.

### NCPNAU

**Usage:** For customized functions. Use the NCPNAU definition statement if you include IBM special products or user-written code to add special device support and functions to your NCP. NCPNAU defines the names of user-defined control blocks and function vector tables associated with a network addressable unit (NAU). Also use NCPNAU to assign a specific name to this NAU and to tell NCP whether the NAU will function as an SSCP or as a logical unit.

**Position:** Follows the SYSCNTRL definition statement. For more information on positioning NCPNAU definition statements see “Position” for the GWNAU definition statement on page 1-10.

### GWNAU

**Usage:** Use the GWNAU definition statement if you include the SNA network interconnection function to connect two or more independent networks. GWNAU reserves addresses in the gateway NCP used by logical units and SSCPs that participate in cross-network sessions. GWNAU also specifies characteristics assigned to these addresses, such as the identity of the logical unit or SSCP using each address and the number of sessions in which the logical unit or SSCP assigned to each address participates.

Code one GWNAU definition statement for each logical unit and SSCP in a nonnative network that requires a permanent address in the native network or a guaranteed number of sessions with logical units or SSCPs in the native network. Also code one GWNAU statement to define the number of addresses set aside in a pool for temporary use by logical units and SSCPs in nonnative networks that participate in cross-network sessions with logical units and SSCPs in the native network.

**Position:** When defining specifications for logical units and SSCPs in nonnative networks that require addresses in the native network, GWNAU must follow the NCPNAU or SYSCNTRL definition statement.

The GWNAU definition statement that generates the pool of network addressable units (NAUs) must be the last definition statement in the sequence of GWNAU or NCPNAU definition statements within a network.

To maintain address stability on subsequent gateway NCP generations, follow these rules:

- Do not delete a GWNAU or NCPNAU definition statement unless it is the last statement in the sequence of GWNAU or NCPNAU statements that define logical units and SSCPs and it is before the final GWNAU definition statement that generates the pool of NAUs.
- Always add new GWNAU and NCPNAU definition statements within a network *after* all existing GWNAU and NCPNAU statements that define logical units and SSCPs, and *before* the final GWNAU definition statement that generates the pool of NAUs.

Alternatively, maintain address stability for the units that need it (for example, certain SSCPs) by coding ELEMENT on the GWNAU definition statement. As long as the value of ELEMENT does not change, the gateway address does not change.

Code GWNAU definition statements in ascending order according to the values of the ELEMENT keywords. GWNAU statements with ELEMENT defined must precede all other GWNAU definition statements and any NCPNAU statements in a network.

### HOST

**Usage:** Required only for VTAM. Use one HOST definition statement for each VTAM that can activate NCP. The NCP generation procedure does not use the HOST definition statement. See *VTAM Resource Definition Reference* for a complete description of HOST.

**Position:** Must precede the first GROUP definition statement.

## IDLIST

**Usage:** Use the IDLIST definition statement if you attach BSC devices or TWX terminals to a switched link connected to an NCP communicating with TCAM. IDLIST specifies a list of identification sequences for these devices, the maximum size of the identification list, and the action NCP performs when it receives an identification sequence that does not match any sequence in the list.

Specify one IDLIST definition statement for each list of identification sequences checked by NCP.

An identification list is optional for each switched line that BSC or TWX devices can call or for each switched line that the controller, in network control mode, can call. If you provide a list, NCP checks identification sequences it receives from a device against the sequences in the list. If you do not provide a list, no check is made. The same list can be used for more than one line.

TCAM can check identification sequences received from devices calling the controller instead of, or in addition to, NCP. Identification sequences received during callout operations are never passed to TCAM. Refer to the appropriate TCAM installation manual for information about identification verification.

**Note:** IDLIST is not valid for VTAM.

**Position:** Must precede the first GROUP definition statement.

## LUPOOL

**Usage:** Use the LUPOOL definition statement if you attach logical units associated with type 1 and type 2 physical units to switched SDLC links. LUPOOL defines a pool of logical unit control blocks (LUBs) used when the connection is established between NCP and the type 1 or type 2 physical units.

Specify one LUPOOL for each access method that communicates with type 1 and type 2 physical units over switched SDLC telecommunication links using the assign network address (ANA) command. Do not code LUPOOL for any access method that supports request network address assignment (RNAA) instead of ANA.

**Position:** Must precede the first GROUP definition statement.

## LUDRPOOL

**Usage:** Use the LUDRPOOL definition statement if you include the dynamic reconfiguration function or connect any switched SDLC links to your NCP. LUDRPOOL specifies pools of empty logical unit control blocks (LUBs) used when you add a logical unit to an SDLC device by dynamic reconfiguration, or when a connection is established between NCP and an SDLC device attached to a switched link.

**Token Ring:** If you include Token-Ring resources in your generation definition, code the LUDRPOOL definition statement.

**Position:** Must precede the first GROUP definition statement.

### PUDRPOOL

**Usage:** Use the PUDRPOOL definition statement if you include the dynamic reconfiguration function in your NCP. PUDRPOOL specifies a pool of empty physical unit control blocks used when an SDLC device is added by dynamic reconfiguration to a link connected to your NCP.

**Position:** Must precede the first GROUP definition statement.

### PATH

**Usage:** Required. PATH specifies the explicit routes, adjacent subareas, and transmission groups used to send data to the destination subareas. Use the PATH definition statement to specify one or more destination subareas that receive data from NCP. PATH also specifies data flow thresholds for the transmission groups used. In addition, PATH assigns virtual routes to the explicit routes used and defines pacing window sizes for these virtual routes.

If you define a gateway NCP, see the description of PATH on page 1-23.

**Position:** Must precede the first GROUP definition statement.

### SDLCST

**Usage:** Use the SDLCST definition statement if your NCP is connected to an adjacent NCP by one or more point-to-point SDLC, Token-Ring, frame-relay, or ISDN subarea links.

SDLCST specifies a set of parameters in a selection table used by a subarea link and defines whether this set of parameters is used when your NCP is operating in a primary or secondary state. You can designate a primary and a secondary NCP by defining one SDLCST definition statement for the primary NCP and one SDLCST definition statement for the secondary NCP.

See Figure 1-1 on page 1-13 for an example of the primary and secondary roles of NCP. In Figure 1-1, the values coded on the GROUP, LINE, and PU definition statements govern operation of the subarea link. As long as NCP1 and NCP2 exchange identifications during the contact procedure, they determine which controller is the primary device and which one is secondary. You can specify which controller is to be the primary controller, regardless of its subarea controller number; however, if you do not specify which device is to be the primary one, the one with the higher subarea number becomes the primary device. Each NCP then replaces the subarea link parameters with those values you coded or those that default on SDLCST for that device type (primary or secondary), with the exception of the MAXOUT keyword for the primary NCP.

**Position:** Must precede the first GROUP definition statement.

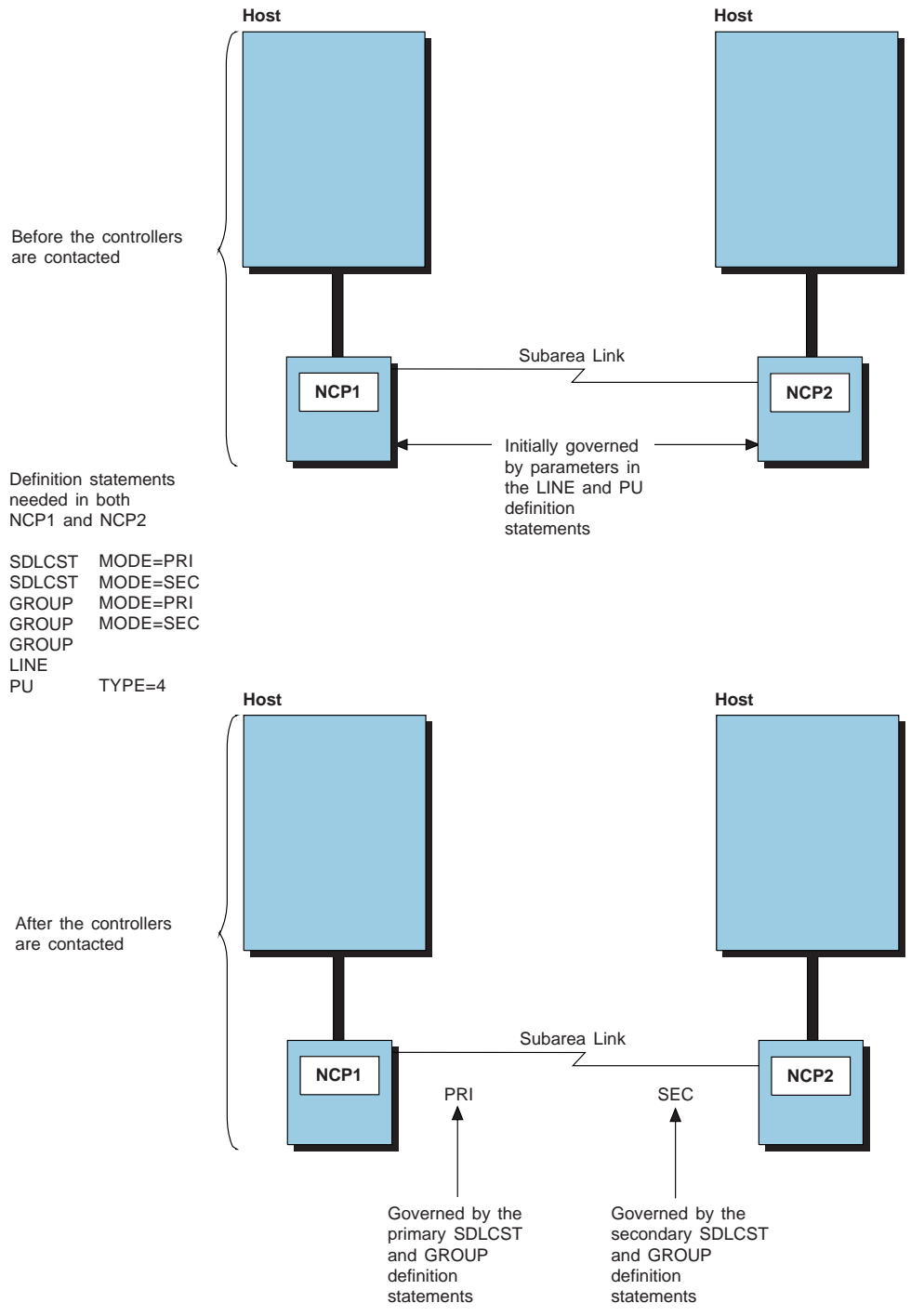

Figure 1-1. Determination of Primary and Secondary Roles by Communication Controllers

## DIALSET

**Usage:** Use the DIALSET definition statement if you attach BSC or start-stop devices to a switched link connected to your NCP. DIALSET specifies the switched, point-to-point links that make up a dial set, which is a group of telecommunication links. NCP dials a device over one link selected from the dial set.

Specify one DIALSET definition statement for each dial set defined.

## Definition Statement Usage and Sequence

**Position:** Must precede the first GROUP definition statement.

### MTALCST

**Usage:** Use the MTALCST definition statement if you have switched multiple-terminal-access (MTA) links for certain start-stop devices attached to your NCP. MTALCST defines entries in a line-control selection table generated in NCP for the devices that use the MTA links. These entries describe terminal operating characteristics, such as line speed, transmission code, line control, length of print line, carriage return rate, text error retry limit, buffer cutoff limit, and a mask and compare character for TWX terminals.

Specify one MTALCST definition statement for each line-control selection table entry defined.

**Position:** Must precede the first GROUP definition statement. All MTALCST definition statements must appear together for an MTALCST group.

### MTALIST

**Usage:** Use the MTALIST definition statement if you have switched MTA links for certain start-stop devices attached to your NCP. MTALIST specifies the types of terminals that use the MTA link.

Specify one MTALIST definition statement for each list of line control types for MTA links.

**Position:** Must follow the group of MTALCST definition statements for switched link or links. Must precede the first GROUP definition statement.

### MTAPOLL

**Usage:** Use the MTAPOLL definition statement if you have switched MTA links for IBM 1050 Data Communication System devices attached to your NCP. MTAPOLL defines the polling characters used by IBM 1050 Data Communication System terminals that can call the communication controller over any dial-in MTA link.

Specify one MTAPOLL definition statement for all IBM 1050 terminals that can dial the controller over any MTA link.

**Position:** Must precede the first GROUP definition statement.

### MTATABL

**Usage:** Use the MTATABL definition statement if you have switched MTA links for certain start-stop devices attached to your NCP. MTATABL specifies the line control and transmission code used by the devices defined in the MTALCST definition statement. Also it defines the name of each MTALCST definition statement that represents a set of operating parameters for these devices.

Specify one MTATABL definition statement for each unique combination of line control types and transmission codes for MTA links.

**Position:** Must precede the first GROUP definition statement.

## SWMMT

**Usage:** Use the SWMMT definition statement to define SSCP monitor mode function (SMMF) for switched subarea lines. Code the SWMMTID keyword on the LINE definition statement to point to the name you assign to the first SWMMT definition statement in the switched table.

**Position:** Follows the BUILD and SYSCNTRL definition statements. Must precede the first GROUP definition statement.

## GROUP

**Usage:** Required. Use the GROUP definition statement to begin a series of definition statements that define the characteristics common to a group of links or devices attached to your NCP. GROUP specifies such characteristics and functions as:

- The type of line control to be used
- Optional or variable characteristics that all lines in the group have in common
- Certain options to be applied to all lines in the group
- For 370 I/O channel attachments, the characteristics of channel links
- For Token-Ring, frame-relay, and ISDN lines, whether a group contains physical or logical lines.

The GROUP definition statement has two special uses: channel link definitions and stand-alone GROUP definitions. See Chapter 4 for information about channel links; the following section describes stand-alone GROUP definition statements.

### Stand-Alone GROUP Definition Statements

A stand-alone GROUP definition statement is a GROUP definition statement that is not followed by LINE and lower-level definition statements. Use a GROUP definition statement to define a stand-alone line group (1) for a subarea link selection table or (2) for MTA support when there is no non-MTA GROUP definition statement with the same values specified for the TERM, POLLED, and FEATURE keywords.

For an SDLC selection table, code the keywords shown in Figure 1-2.

APRI	SDLCST GROUP=A,MODE=PRI	Primary selection table entry
*		
ASEC	SDLCST GROUP=B,MODE=SEC	Secondary selection table entry
*		
A	GROUP MODE=PRI	Primary line group operation mode
*		
B	GROUP MODE=SEC	Secondary line group operation mode
*		
SDLCGRP	GROUP SDLCST=(APRI,ASEC)	SDLC line group
	.	
	.	
	.	

Figure 1-2. Example: Defining a Stand-Alone SDLC Line Group

To define a stand-alone line group for MTA, code the keywords shown in Figure 1-3 on page 1-16.

## Definition Statement Usage and Sequence

```
MTAGRP  GROUP  DIAL=YES,  
            LNCTL=SS,  
            TERM=2740-1,1  
            POLLED=YES,2  
            FEATURE=(XCTL,CHECK),2  
            .  
            .  
            .
```

1 You can also code 1050, 2741, or TWX  
2 Only for TERM=2740-1

Figure 1-3. Example: Defining a Stand-Alone MTA Line Group

Code other GROUP definition statement keywords for the stand-alone GROUP definition statement. However, for a stand-alone GROUP definition, any LINE or TERMINAL definition statement keywords that you code for a regular GROUP definition statement are ignored.

Specify one GROUP definition statement for each telecommunication link group, even if the group is made up of only one link.

**Position:** Appears at the beginning of the definition for each type of telecommunication link. The type of line control used by the group determines the position of the group definition within the system generation definition. See “How You Define Resources to NCP” on page 1-4 for information on the order of line group definition statements in the system generation definition.

## LINE

**Usage:** Required. Use the LINE definition statement to specify characteristics and functions for a single physical or logical line. These characteristics and functions include:

- The speed of the link
- The address of the link
- Whether the modem or communication scanner provides clocking
- Whether the link and modem constitute a duplex or half-duplex facility
- The number of attempts NCP is to make to recover from errors occurring during transmission of data over the link.

Specify one LINE definition statement for each BSC or start-stop communication line connected to the controller, whether it operates only in network control mode or in either network control or emulation mode. For an SDLC link, a single LINE definition statement represents either one or two communication line interfaces. Parallel links must have a LINE definition statement to define each link. If all the links have the same group characteristics, they can be defined following the same GROUP definition statement. If no TERMINAL definition statements follow a LINE for a BSC or start-stop line, specify CALL=OUT (VTAM) and the device type (TERM keyword) on the LINE or GROUP definition statement. You also can code the FEATURE keyword on the TERMINAL definition statement for that line. All other TERMINAL definition statement keywords are ignored.



The LINE definition statement also defines channel link characteristics and functions such as channel operations, logical address or physical position, and peripheral host node connection or subarea host node connection.

**Position:** Can follow other LINE definition statements as well as GROUP, PU, LU, TERMINAL, or COMP definition statements. LINE definition statements representing SDLC links must appear in the generation definition following LINE statements representing BSC and start-stop lines. Definitions for channel links follow SDLC links. For more information, read “How You Define Resources to NCP” on page 1-4.

All LINE definition statements representing lines in a physical line group must appear between the GROUP representing that group and the next GROUP definition statement.

**Note:** If you define an SDLC peripheral line as the only line under a GROUP definition statement, you can use NTuneMON to change certain characteristics of the line as long as the line is inactive. See the *NTuneMON User's Guide* for details.

## DLCI

**Usage:** Frame-relay physical lines. Use the DLCI definition statement to specify one of the following:

- Bandwidth management parameters for 3746 Model 900 frame-relay DLCIs
- A balancing factor for 3745 frame-relay DLCIs

A DLCI statement may be coded for each DLCI that can be supported by the physical line. However, a DLCI statement is not required for every DLCI supported by the physical line.

No more than one DLCI statement may be coded for a given DLCI on a physical line.

**Position:** Follows the LINE definition statement.

## SERVICE

**Usage:** For nonswitched links. Use the SERVICE definition statement to generate a service order table for a nonswitched link connected to NCP. SERVICE specifies the order in which the devices attached to the link are serviced and the maximum number of entries in the table. If the link is an SDLC link, define each physical unit on the link at least once. If the link is BSC or start-stop, specify each CLUSTER, TERMINAL, and COMP definition statement at least once.

Do not specify a SERVICE definition statement for subarea links connecting two NCPs, switched links, or point-to-point links. You can define one SERVICE definition statement for all other types or permit NDF to generate it by default.

**Note:** If you omit the SERVICE definition statement, or code it and omit the ORDER keyword, NDF automatically generates the service order table.

**Position:** Follows the LINE definition statement.

### CLUSTER

**Usage:** Use the CLUSTER definition statement if you attach clustered BSC stations (IBM 3270 Information Display Systems or IBM 2972 General Banking Terminal Systems) to your NCP. CLUSTER specifies such characteristics and functions as:

- The type of station
- Any required general polling characters used by the cluster controller attached to the station
- The name of the station if general polling characters are used
- Any block handler sets associated with the station
- Points of block handler execution within the block handler set
- Certain operation options used when NCP communicates with the clustered station.

CLUSTER represents an IBM 3270 series only if the line is nonswitched (DIAL=NO on GROUP and POLLED=YES on the LINE or GROUP definition statement). Each CLUSTER statement generates a resource name only if the GPOLL keyword is coded. Omit GPOLL if the general polling function is not required.

Define one CLUSTER definition statement for each cluster controller.

**Position:** It follows the SERVICE definition statement. If you do not code SERVICE, the CLUSTER definition statement follows the LINE definition statement. It precedes the TERMINAL and COMP definition statements for the cluster.

Code CLUSTER definition statements following a LINE definition statement if the following conditions apply:

- The line is a BSC link (LNCTL=BSC on GROUP).
- The line operates only in network control mode.
- The line is nonswitched (DIAL=NO on GROUP).
- The line uses multipoint line control (POLLED=YES on LINE).

### TERMINAL

**Usage:** Use the TERMINAL definition statement if you attach BSC or start-stop devices to your NCP. The TERMINAL definition statement represents the first or only input or output component of a device. TERMINAL specifies such characteristics and functions as:

- The device name
- Device type
- Device features
- The polling and addressing characters NCP uses to contact the device
- The telephone number NCP uses to reach the device
- The length of the controller identification sequence NCP sends to the device when contact is established

- Any block handler set associated with the device
- Points of block handler execution within the block handler set
- Certain operation options used when NCP communicates with the device.

Specify one TERMINAL definition statement for each BSC or start-stop device, including those attached to cluster controllers.

Represent each start-stop and BSC device attached to a nonswitched point-to-point or multipoint line by a separate TERMINAL definition statement. Represent all terminals attached to an IBM 3270 series control unit with TERMINAL.

**Note:** TERMINAL definition statements can be required for unused terminal addresses on certain BSC control units. If FEATURE=GPLKUP is coded, extra TERMINAL definition statements are not needed.

Devices that call the communication controller over the switched telephone network are not represented individually by TERMINAL definition statements. Instead, TERMINAL is required for each controller connection (port) that receives calls. The control blocks generated by each TERMINAL represent whichever device is connected to the controller for the duration of any given call.

Devices called by the controller are represented by either a unique TERMINAL definition statement or a common TERMINAL definition statement that represents whichever device the controller is connected to during any given call.

Code a unique TERMINAL definition statement for each device for which a telephone number is maintained within the controller. Specify the telephone number of the device on the DIALNO keyword. Code a common TERMINAL to represent all devices for which VTAM supplies a telephone number.

Each TERMINAL definition statement generates a resource name and applies only to lines operating in network control mode.

If the device specified by this TERMINAL is an IBM 3275 or a device attached to an IBM 3270 series (except 3275) control unit, represent the control unit with a CLUSTER definition. Do not code a TERMINAL statement for a printer attached to an IBM 3275 (TERM=3275).

**Position:** It follows the SERVICE definition statement. If you do not code SERVICE, the TERMINAL definition statement follows the LINE definition statement. If part of a cluster, the TERMINAL definition statements for the cluster follow the CLUSTER definition statement.

## COMP

**Usage:** Use the COMP definition statement if you attach BSC or start-stop devices to an NCP. COMP specifies characteristics and functions for each I/O component of the devices, such as:

- The component name
- Polling and addressing characters NCP uses to contact the component
- Any block handler set associated with the component
- The execution time of block handlers within the block handler set
- Certain operation options NCP uses to communicate with the component.

## Definition Statement Usage and Sequence

COMP statements are required only for components NCP must poll or address individually with specific component polling or addressing characters. COMP is not required for a device with only one input and one output component since the TERMINAL definition statement specifies polling and addressing characters. If two or more components need to have separate sessions established concurrently, represent each component with an individual TERMINAL or COMP definition.

Each COMP generates a resource name. Keywords on COMP apply only to lines operating in network control mode.

Specify one COMP definition statement for each additional input or output component.

**Position:** Follows the TERMINAL definition statement or other COMP definition statements.

## PU

**Usage:** Use the PU definition statement if NCP is attached to SDLC, frame-relay, ISDN, or Internet Protocol devices, if NCP has channel adapter connections, or if your NCP is connected to an adjacent NCP by one or more SDLC subarea links. PU specifies such characteristics and functions as:

- The device name
- The device address and type
- The maximum amount of data the physical unit can receive from NCP in one path information unit (PIU) or PIU segment
- The maximum number of consecutive PIUs or PIU segments NCP is to send to the device before servicing other devices on the link
- Whether an immediate polling retry is required for the device
- The number of error recovery attempts NCP is to make if transmission errors occur
- The maximum number of PIUs or PIU segments NCP is to send to the device before requesting a response
- The maximum number of logical units associated with the device.

Specify one PU definition statement for each device and link station.

Use PU definition statements to define subarea channel or peripheral channel links. Subarea channel links and peripheral channel links require only one PU definition statement for each LINE definition statement. Do not code a PU definition statement for EP channels. For Internet Protocol, the PU definition statement defines a link station. For frame relay the PU definition statement defines a subport.

**Position:** Follows the LINE, SERVICE, LU, or other PU definition statements if the other PU definition statement defines a device that is attached to a nonswitched link. If defining a link station, PU follows the LINE definition statement. If defining a device attached to a multipoint link or a point-to-point link used for dynamic reconfiguration, PU follows the SERVICE definition statement. If you do not code SERVICE, PU follows the LINE definition statement.

## IPHOST

**Usage:** For internet routing over Ethernet-type and NTRI-attached LANs. Use the IPHOST definition statement to define a permanent internet host on an Ethernet-type or NTRI-attached LAN. This definition statement is necessary only for internet hosts that do not support Address Resolution Protocol (ARP) packets. You can code more than one IPHOST statement for each local LAN.

**Position:** Must follow a PU definition statement for an Ethernet-type or NTRI-attached LAN or another IPHOST definition statement.

## LU

**Usage:** Use the LU definition statement if you attach SDLC devices to your NCP, if you have channel adapter connections, or for NCP connectionless SNA transport (NCST) definitions. The LU statement specifies such characteristics and functions as:

- The name of the logical unit associated with an SNA device
- The logical unit address and type
- Whether NCP requires the logical unit to acknowledge, at intervals, receipt of data and readiness to accept more data
- The definition of a peripheral host.

Specify one LU definition statement for each logical unit associated with a device on a nonswitched link.

**Position:** Follows the PU definition statement or other LU definition statement associated with the same device. LU definition statements appear in ascending order according to local addresses assigned to logical units (as coded for LOCADDR on this definition statement). LU definition statements are required for local addresses with associated logical units. The generation procedure generates logical unit control blocks for each defined local address.

When you define a peripheral channel link (PUTYPE=2) on the PU definition statement, also define an LU definition statement. You can code the LU definition statement in the generation definition or it can be added dynamically. However, an LU definition statement cannot follow a subarea channel link (PUTYPE=5) definition.

## FRSESET

**Usage:** Use the FRSESET definition statement to define frame-relay subport sets. A subport set defines the portion of the permanent virtual circuit (PVC) between two, three, or four subports within:

- An NCP running on a 3745,
- A 3746 Model 900, or
- A combination of a 3746 Model 900 and an NCP (starting with V7R4) running on a 3745.

**Position:** Must follow all subport PU definition statements referenced by this FRSESET definition statement and precede the GENEND definition statement.

### ENDAUTO

**Usage:** Use the ENDAUTO definition statement if you use automatic line generation. The ENDAUTO definition statement indicates the end of a block of definition statements to be copied by the autoline function. The ENDAUTO definition statement also indicates the end of a block of definition statements to be copied by the autocopy function.

Specify one ENDAUTO definition statement for each block of definition statements to be copied.

**Position:** Follows all CLUSTER, TERMINAL, and COMP definition statements for a LINE definition statement containing the AUTOLINE or AUTOCOPY keyword for a BSC or start-stop line. Follows all PU and LU definition statements for a LINE definition statement containing the AUTOLINE or AUTOCOPY keyword for an SDLC line.

### IPOWNER

**Usage:** For internet routing, use the IPOWNER definition statement to define the NCP owning IBM TCP/IP host.

**Position:** Must follow the last line group definition, and must precede all IPLOCAL and IPRROUTE definition statements and the GENEND definition statement.

### IPLOCAL

**Usage:** For internet routing. Use the IPLOCAL definition statement to specify the internet address for a local gateway routing interface. IPLOCAL also implicitly defines an internet route from the interface to the adjacent LAN or NCST logical unit, frame-relay network, channel-attached internet host, or internal NCP to Model 900 point-to-point IP connection. Code a 4-byte internet address for each of the local routing interfaces defined to NCP. These addresses are used to route datagrams throughout the network.

**Position:** Must follow the IPOWNER definition statement, and must precede all IPRROUTE definition statements and the GENEND definition statement.

### IPROUTE

**Usage:** For internet routing. Use the IPRROUTE definition statement to define a route in the internet route table. IPRROUTE is needed only for routes that are not implicitly defined or that cannot be dynamically discovered through Routing Information Protocol.

**Position:** Must follow the IPOWNER definition statement and all IPLOCAL definition statements, and must precede the GENEND definition statement.

### NETWORK

**Usage:** Use the NETWORK definition statement if you include the SNA network interconnection function to connect two or more independent networks. NETWORK specifies characteristics of the nonnative networks that connect to the gateway NCP, such as:

- The name of the nonnative network
- The subarea address that identifies the gateway NCP to the nonnative network

- The maximum number of subareas in the nonnative network that can simultaneously have active virtual routes connecting them with the gateway NCP
- Whether access methods in the nonnative network can activate or own the gateway NCP
- Limits of the nonnative network.

Code the NETWORK definition statement to define resources that enable the gateway NCP to define nonnative network characteristics dynamically. This permits the gateway NCP to support cross-network sessions with nonnative networks that are not explicitly defined to it.

Each NETWORK definition statement is followed by GWNAU definition statements defining cross-network resources and PATH definition statements defining paths in this network. You cannot define peripheral function resources under a NETWORK definition statement. Define them in the native NCP, under the BUILD definition statement. Specify one NETWORK definition statement for each nonnative network connected to the gateway NCP.

**Position:** Follows the device definition statements (GROUP, LINE, CLUSTER, TERMINAL, COMP, PU, and LU) for native resources attached to the gateway NCP. Can also follow a PATH definition statement associated with the previous nonnative network.

## GWNAU

**Usage:** Use the GWNAU definition statement to define a gateway NCP when GWNAU follows the NETWORK definition statement. See page 1-10 for a full description of the GWNAU definition statement.

Code one GWNAU definition statement for each logical unit and SSCP in any network (native or nonnative) that requires a permanent address in the nonnative network defined on the preceding NETWORK definition statement. It can also define a guaranteed number of sessions with logical units or SSCPs in that nonnative network.

Code one GWNAU definition statement to define the number of addresses set aside in a pool for temporary use by logical units and SSCPs in any network that participates in cross-network sessions with logical units and SSCPs in the nonnative network defined by the preceding NETWORK definition statement. Also, code one GWNAU definition statement to define the number of addresses set aside in a pool for temporary use by logical units and SSCPs in networks added dynamically by the gateway NCP.

**Position:** Follows the NETWORK definition statement for a nonnative network that requires addresses of logical units and SSCPs in any other native or nonnative network.

## PATH

**Usage:** For gateway NCPs (when following GWNAU definition statement). Use the PATH definition statement to specify one or more destination subareas that receive data from the gateway NCP. Code one PATH definition statement for each destination subarea in a nonnative network that receives data from the gateway NCP.

## Definition Statement Usage and Sequence

PATH specifies the explicit routes, adjacent subareas, and transmission groups used to send data to the destination subareas. PATH also specifies data flow thresholds for the transmission groups used. In addition, PATH assigns virtual routes to the explicit routes used and defines pacing window sizes for these virtual routes.

**Position:** When defining routes to destination subareas in a nonnative network, follows GWNAU definition statements associated with the nonnative network defined by the preceding NETWORK definition statement.

## STARTBH

**Usage:** For BSC or start-stop devices. Use the STARTBH definition statement to specify the name of a block handler, and the point at which the block handler is executed.

Specify one STARTBH definition statement for each block handler.

**Position:** Appears at the beginning of a block handler.

## EDIT

**Usage:** For BSC or start-stop devices. Use the EDIT definition statement to specify a character used as a text canceling (backspace) character.

Specify no more than one EDIT definition statement for each block handler.

**Position:** Appears before the DATETIME definition statement, if DATETIME is coded.

## DATETIME

**Usage:** For BSC or start-stop devices. Use the DATETIME definition statement to specify whether NCP inserts the date, time of day, or both in a block of data that NCP is processing.

Specify no more than one DATETIME definition statement for each block handler.

**Position:** Follows the EDIT definition statement, if EDIT is coded.

## UBHR

**Usage:** For BSC or start-stop devices. Use the UBHR definition statement only if you include a user-written block handling routine in a block handler. You can code any number of UBHR definition statements. UBHR specifies the name of the user-written routine, its entry point, and the conditions under which it runs.

**Note:** Using UBHR forces storage boundary alignment to the next 2KB (KB equals 1024 bytes) boundary because of the storage-protection feature of the communication controller. Therefore, up to 2KB of storage can be unused when NCP is loaded into the controller.

**Position:** Appears in any sequence between the STARTBH and ENDBH definition statements.



### REMOVCTL

**Usage:** For start-stop devices. Use the REMOVCTL definition statement to specify whether NCP removes the ending control characters from incoming data blocks for TWX terminals, World Trade Teletypewriter (WTTY) terminals, Western Union Plan 115A Outstations, and 83B3 Selective Calling Stations. REMOVCTL removes characters only from control blocks in which an ending sequence was detected. A block handler routine must be specified to execute at point 2.

Specify no more than one REMOVCTL definition statement for each block handler.

**Position:** Appears in any sequence between the STARTBH and ENDBH definition statements.

### ENDBH

**Usage:** For BSC or start-stop devices. Use the ENDBH definition statement to specify the end of a block handler. Code one ENDBH definition statement for each block handler.

**Position:** Appears at the end of a block handler.

### BHSET

**Usage:** For BSC or start-stop devices. Use the BHSET definition statement to specify the name of a set of block handlers, whether the block handler set can be executed when it is associated with a device by command from the host processor, and the point at which the block handler set is executed.

Specify one BHSET definition statement for each block handler set needed.

**Position:** Must follow all block handler definition statements of a block handler set.

### GENEND

**Usage:** Required. Use the GENEND definition statement to end NCP generation definition and to specify certain characteristics of any user-written code in NCP.

**Position:** Last in NCP generation definition unless you code the OPTIONS definition statement last.

---

## Definition Statements for Dynamic Reconfiguration

The following definition statements are used only for dynamic reconfiguration. They do not appear in the NCP generation definition.

### ADD

**Usage:** Use the ADD definition statement for dynamic reconfiguration. Specify one for each physical unit you want to add to an existing link or one for each logical unit you want to add to a physical unit.

**Position:** In a separate generation definition, before a PU definition statement or an LU definition statement. If you specify the name of a link in this ADD definition statement, ADD precedes a PU definition statement. If you specify a physical unit in the ADD definition statement, ADD precedes an LU definition statement.

## Definition Statements for Dynamic Reconfiguration

### DELETE

**Usage:** Use the DELETE definition statement for dynamic reconfiguration. Specify one DELETE definition statement for each physical unit or logical unit you want to delete from an existing link or physical unit.

**Position:** In a separate generation definition, before a PU or an LU definition statement. If you specify the name of a link in this DELETE definition statement, DELETE precedes a PU definition statement. If you specify a PU in the DELETE definition statement, DELETE precedes an LU definition statement.

---

## Chapter 2. Generating an NCP Load Module

Once you have coded a generation definition to define the NCP resources for your network, you need to process the generation definition to create an NCP load module to load into your communication controller. The NCP/EP definition facility (NDF), an SSP program, processes your generation definition to create a set of NCP object modules. You then link-edit this set of object modules to create an NCP load module for your controller. This chapter describes keywords that control various aspects of the NDF generation process. For more information on generating, link-editing, and loading NCP, refer to *NCP, SSP, and EP Generation and Loading Guide* and *VTAM Network Implementation Guide*.

**Note:** Your NCP generation definition must be coordinated with your VTAM generation definition. See “Defining the NCP Environment” on page 2-5 for more information.

---

### NDF-Generated Definition File

NDF adds certain definition statements and keywords to your NCP generation definition during the generation process if the generation definition includes any of the following resources:

- Automatic line generation using the autoline or autocopy function
- Frame-relay resources
- ISDN resources
- Internet routing support
- NCP/Token-Ring interconnection (NTRI)
- Network Routing Facility (NRF)
- User-written generation applications that modify the generation definition
- Enterprise Systems Connection (ESCON) adapters
- 3746 Model 900 Token-Ring adapters
- X.25 packet switching data network (PSDN) connections (supported by NCP X.25 outboard data link control (ODLC) and the NCP Packet Switching Interface (NPSI)). For information about defining resources in X.25 packet switching networks, see *NCP Version 7 and X.25 NPSI Version 3 Planning and Installation*.

When you define any of these resources, you need to direct NDF to create a new system generation definition file as part of the generation process. This new file, called the *NEWDEFN file*, contains your original generation definition, along with the definition statements and keywords added by NDF. Use the *NEWDEFN file*, rather than your original generation definition, as the *VTAMLST* input to the VTAM activation process.

If your NCP generation definition does not include any of these resources, you do not need to generate a *NEWDEFN file*.

Code the following definition statement and keywords to create a *NEWDEFN file*.

OPTIONS	NDNAME NEWDEFN
---------	-------------------

NDNAME on the OPTIONS definition statement (VSE only) causes NDF to catalog the NEWDEFN file automatically. NDNAME specifies the name under which the NEWDEFN file is to be cataloged.

NEWDEFN specifies whether NDF is to create a NEWDEFN file, and defines certain characteristics of the NEWDEFN file.

The second suboperand of NEWDEFN (ECHO or PACK) specifies the form of the NEWDEFN file. If you specify ECHO, the NEWDEFN file matches the input generation definition as closely as possible, including comments. If you specify PACK, NDF condenses the NEWDEFN file by removing comments and concatenating the keywords.

The third suboperand of NEWDEFN (SUPP or NOSUPP) specifies whether NDF is to add comments to the NEWDEFN file to identify the generation load module that passed the definition statements and keywords added by NDF. If you specify SUPP, these comments are suppressed.

### Sample System Generation Definition Using the NEWDEFN Keyword

Figure 2-1 shows how to define a system generation definition that uses the NEWDEFN keyword.

	OPTIONS	NEWDEFN=(YES,PACK)	PACK or ECHO can be used
	PCCU	CUADDR=020,	Channel attachment address
		MAXDATA=4096,	Maximum PIU size
		SUBAREA=1	Host subarea address
*			
PEP020	BUILD	MODEL=3745-410,	Controller model
		NETID=NETA,	Network ID
		VERSION=V7R8,	NCP version
		SUBAREA=2,	NCP subarea address
		TYPGEN=PEP,	PEP
		NEWNAME=PEP3745,	Name of the NCP gen
		TEST=YES,	Control panel testing
		USGTIER=5,	Usage tier
		.	
		.	
		.	

Figure 2-1. Example: Defining a New Generation Definition

Figure 2-2 on page 2-3 shows the result when you choose the PACK option for NEWDEFN in the NCP generation definition. Notice that NDF removed the comments and concatenated the keywords in the NEWDEFN file.

```

OPTIONS NEWDEFN=(YES,PACK)
PCCU CUADDR=020,MAXDATA=4096,SUBAREA=1
PEP020 BUILD MODEL=3745-410,NETID=NETA,VERSION=V7R8,SUBAREA=2,TYPGEN=*
      PEP,NEWNAME=PEP3745,TEST=YES,USGTIER=5

```

Figure 2-2. Example: Packed NEWDEFN File

## Reusable NEWDEFN File

You can cause NDF to create a reusable NEWDEFN file to define new resources to NCP or to change the existing configuration of your system. The NEWDEFN file can be modified and resubmitted to NDF. To make the NEWDEFN file reusable, code REUSE as the fourth suboperand of the NEWDEFN keyword. If you use the migration aid function, NDF creates a reusable NEWDEFN file by default. If you specify NOREUSE, the migration aid function writes NOREUSE to the NEWDEFN file it generates. When you submit this NEWDEFN file to NDF, NDF does not generate a reusable NEWDEFN file.

In the reusable NEWDEFN file, NDF encloses the statements it generates inside IGNORE and NOIGNORE statements. Later, when processing the NEWDEFN file as the NCP generation definition, NDF ignores the IGNORE and NOIGNORE pair and everything between them. This way NDF does not create duplicate definitions.

**Note:** Do not modify the IGNORE or NOIGNORE statements or anything between them.

### Sample Coding to Produce a Reusable NEWDEFN File

Figure 2-3 shows part of a generation definition for defining NTRI resources. The OPTIONS definition statement in this coding example causes NDF to produce a reusable NEWDEFN file.

```

OPTIONS NEWDEFN=(YES,ECHO,NOSUPP,REUSE)
.
.
.
A04TRPG1 GROUP ECLTYPE=PHYSICAL,
.
.
.
A04TR16 LINE ADDRESS=(016,FULL),
.
.
.
A04TRLGA GROUP ECLTYPE=LOGICAL,      Logical connection
      AUTOGEN=2,
      CALL=INOUT,
      MODETAB=AMODETAB,
      USSTAB=AUSSTAB,
      ANS=CONTINUE,
      PHYPORT=NONE      Communicate with any port address
.
.
.
GENEND GENEND

```

Figure 2-3. Example: Defining a Reusable NEWDEFN File

## NDF-Generated Definition File

Figure 2-4 on page 2-4 shows part of the reusable NEWDEFN file generated by NDF. Notice the REUSE comment block and the statements generated by NDF, which are enclosed in IGNORE and NOIGNORE pairs.

```
A04TRPG1 GROUP ECLTYPE=PHYSICAL,
.
.
.
A04TR16 LINE ADDRESS=(016,FULL),
.
.
.
A04TRLGA GROUP ECLTYPE=LOGICAL, Logical connection
                AUTOGEN=2,
                CALL=INOUT,
                MODETAB=AMODETAB,
                USSTAB=AUSSTAB,
                ANS=CONTINUE,
                PHYPORT=NONE, Communicate with any port address
                TYPE=NCP,
                DIAL=YES,
                LNCTL=SDLC,
                LEVEL2=ECLNAVL2,
                LEVEL3=ECLNAVL3,
                LEVEL5=NCP,
                XIO=(ECLNAVXL,ECLNAVXS,ECLNAVXI,ECLNAVXK),
                USERID=(5668854,ECLVBDT,NORECMS,,ECLNMVT),
                LINEADD=NONE,
                LINEAUT=YES,
                MAXPU=1,
                PUTYPE=2,
                XMITDLY=NONE,
                RETRIES=(6,0,0)

*
          IGNORE                               Lines between IGNORE/NOIGNORE
*
                                               will be regenerated
*****
* Note: The REUSE option on the NEWDEFN keyword was processed in this*
* generation definition. Do not modify the IGNORE-NOIGNORE statements*
* or any of the intervening statements generated by NDF.
*
*****
* GENERATED BY NDF
J0004001 LINE UACB=X$L1A
* GENERATED BY NDF
J0004002 PU
* GENERATED BY NDF
J0004003 LINE UACB=X$L2A
* GENERATED BY NDF
J0004004 PU
*
          NOIGNORE                              Lines between IGNORE/NOIGNORE
*
                                               will be regenerated
.
.
.
          GENEND INIT=ECLINIT,
                TMRTICK=ECLTICK,
                UGLOBAL=ECLUGBL
```

Figure 2-4. Example: Reusable NEWDEFN File Created by NDF

## FASTRUN Keyword

It is possible to code a generation definition and test it for syntax errors before attempting a final run, or to generate a NEWDEFN file without creating a load module. Code the following definition statement and keyword to implement either of these NDF functions.

OPTIONS      FASTRUN

FASTRUN on the OPTIONS definition statement causes NDF to check for input errors in the generation definition without creating control blocks. To use the FASTRUN keyword, be sure your JCL or VM EXEC calls only the NDF program and not the linkage editor. Code FASTRUN on OPTIONS as the first executable statement in the generation definition. For more information, see *NCP, SSP, and EP Generation and Loading Guide*.

## Defining the NCP Environment

You can describe your NCP environment by providing information such as the name of the network in which NCP resides, the type of controller in which NCP operates, the type of operating system under which NCP is loaded, and the version number of your NCP. You might not want to code all the keywords described in this section; however, if you do not include them with specific values, the default values are used. For information about the default value of each keyword, consult the *NCP, SSP, and EP Resource Definition Reference*.

Code the following definition statement and keywords to provide NDF with information about the name of the network your NCP belongs to, the type of controller, which NCP version is to be generated, and other resource information relevant to your configuration.

BUILD            DUPADDR  
                   GENLEVEL  
                   LENAME  
                   LOADLIB  
                   MINILOAD  
                   NAMTAB  
                   NETID  
                   NEWNAME  
                   PRTGEN  
                   PUNAME  
                   SUBAREA  
                   TYPGEN  
                   TYP SYS  
                   VERSION

DUPADDR on the BUILD definition statement is used to set the message level for PUs coded with duplicate poll addresses.

GENLEVEL on the BUILD definition statement is a value that NCP and VTAM insert into their control blocks. For VTAM to activate an NCP that it did not gen-

## Defining the NCP Environment

erate and load, the NCP date and time of generation field in the DTG control block must match a similar field in the VTAM control block. The value coded on GENLEVEL is a character string that matches the fields in the NCP and VTAM control blocks. When the character string and the control block values match, VTAM can activate NCP. It is important to read the description of GENLEVEL in *NCP, SSP, and EP Generation and Loading Guide* before you code a value on it.

RGENLEVL on the BUILD definition statement specifies that NDF is to replace the GENLEVEL keyword with the default date and time of the NCP generation. If you have NDF create a NEWDEFN file (with NEWDEFN=YES on the OPTIONS statement), you can use this keyword to cause the date and time of the current generation to be placed in that NEWDEFN file.

LENAME specifies the name of the library member that will contain the link-edit control statements for the generation process. LENAME is valid only when you are generating NCP under the VSE operating system. If this member does not exist at the start of the NCP generation process, it is created by the first step in the generation process and cataloged by the LIBRARIAN used in the link-edit step. You can include your own link-edit statements in the generation process by placing them in this member before you start the generation process. When you do this, NDF appends its own link-edit statements to yours during the earlier steps of the generation process and executes them all during the link-edit step.

LOADLIB is a VTAM keyword that specifies the ddname of the load library VTAM is to use to load NCP.

MINILOAD specifies whether NDF will facilitate the generation of a minimum-sized load module. Generating a minimum-sized NCP load module (not exceeding 1.2 megabytes) is required when you want to store it on a single diskette, which can be used to load and activate a remote 3745 Communication Controller.

**How to Generate a Minimum-Sized Load Module:** In addition to coding MINILOAD=YES, follow these rules to generate a minimum load module:

- Code the following on the BUILD statement:
  - HPR=NO (default)
  - NPA=NO (default)
  - NTUNECOL=NO (default)
  - DYNPOOL=(0,0) (default)
  - VERSION=

Beginning with NCP V7R8, VERSION=VxRyF is valid only when a 3746 Model 900 CSS link is present in the generation definition.

- Define only one physical LINE statement and one physical PU statement, unless a backup physical line path is absolutely required.
- Define the group as a **subarea** attachment, and include the following keywords on the GROUP statement:
  - NPACOLL=NO
  - PUDR=NO
- When a logical line is needed, code only one logical LINE statement and one logical PU statement per physical line.
- Do not define an LU statement.
- Do not define a LUDRPOOL statement.



NAMTAB defines the maximum number of entries in the network names table. One network names table exists for each NCP. Each entry contains a name and a count of the number of uses for this name. The names stored in this table are SSCP names, control point names, and network names received in various session activation PIUs. The minimum number of entries that should be coded for this keyword includes:

1. One for each network in which NCP is defined; one for the native network defined by the BUILD definition statement; and if NCP is a gateway, one for each nonnative network defined by the NETWORK definition statements, including the model network and all copies defined by the COPIES keyword
2. One for each type 2.1 physical unit attached to this NCP for which there is a unique control point

**Note:** Even if your type 2.1 physical unit contains only dependent logical units, you must still reserve a space in the network names table for its control point name.

3. One for each type 2.1 physical unit attached to this NCP that is defined in a unique network

**Note:** Peripheral nodes can be defined in a network other than the native network of the NCP. An entry in the network names table needs to be reserved for each unique network other than the NCP native network that contains type 2.1 physical unit nodes. See "Type 2.1 Support Functions" on page 8-6 for more information on nonnative network attachments.

4. One for each type 2.1 physical unit, not in the boundary of this NCP, that has a unique control point name and has logical units in session with logical units in any type of physical unit in the boundary of this NCP
5. One for each SSCP that has an application in its domain that is in session with logical units in any type of physical unit in the boundary of this NCP
6. One for each network, not defined in this NCP, that has logical units or applications in session with logical units in any type of physical unit in the boundary of this NCP
7. If you use gateway session accounting for this NCP:
  - a. One for each SSCP that has applications in session with logical units that cross the gateway
  - b. One for each type 2.1 physical unit with a unique control point name that has logical units in session with other logical units that cross the gateway
  - c. One for each network that has logical units in session with other logical units that cross the gateway.
8. One for each network, not defined in this NCP, which has logical units in the boundary of this NCP that are in session with this NCP
9. One for each independent logical unit, in the boundary of this NCP, that has a unique control point name and will be in session with this NCP
10. One for each independent logical unit, not in the boundary of this NCP, that has a unique control point name and will have sessions with logical units in the boundary of this NCP.

NETID defines the name of the network NCP resides in.

## Defining the NCP Environment

NEWNAME provides the 7-character name for the NCP load module produced by the generation procedure. NEWNAME is also the resource name for this NCP physical unit if you do not code PUNAME on the PU definition statement.

In addition to creating an NCP load module, NDF produces:

- A resource resolution table (RRT)
- A block handler set resolution (BHR) table, if you include block handling routines
- An internet routing information table (RIT), if you include internet resources.

The RRT and BHR contain information required by the access method. The RIT contains information used by the IBM TCP/IP NCPROUTE server. The value of NEWNAME is the basis for the names of the RRT, BHR, and RIT as follows:

- The name of the RRT is the value of NEWNAME followed by *R*.
- The name of the BHR table is the value of NEWNAME followed by *B*.
- The name of the RIT is the value of NEWNAME followed by *P*.

For more information, refer to *NCP, SSP, and EP Generation and Loading Guide* and *NCP and SSP Customization Guide*.

PRTGEN specifies whether macro-generated statements are to be printed for the NCP table assemblies. The default for PRTGEN causes these statements to be printed.

PUNAME defines the unique physical unit name. The default for PUNAME is the name supplied on the NEWNAME keyword.

SUBAREA specifies the subarea address assigned to NCP or PEP. Each active subarea in a network must have a unique address assigned to it, regardless of the number of SSCPs in that subarea. The only exceptions are as follows:

- A subarea defined in one domain can have the same address as a subarea in another domain if the two domains never communicate with each another.
- Multiple access methods in a system configuration can have the same address if only one communicates with the network at a time.
- SUBAREA is not valid for EP standalone.

TYPGEN specifies that NCP is to operate in a channel-attached controller or a link-attached controller. TYPGEN also determines whether NCP is to include EP functions (PEP). TYPGEN=EP indicates EP standalone. The different types of controller attachments are illustrated in Figure 2-5 on page 2-9.

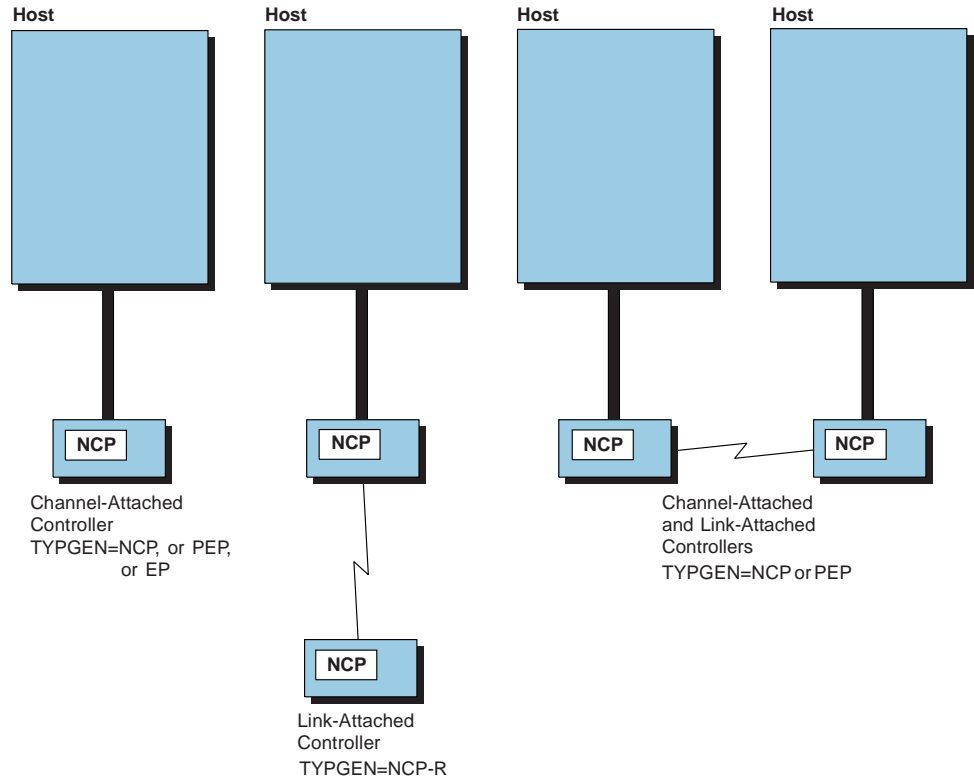

Figure 2-5. NCP in Channel-Attached and Link-Attached Controllers

Network control functions are principally designed for the IBM 3745 Communication Controller. EP functions are those equivalent to functions performed by the IBM 2701 Data Adapter Unit and the IBM 2702 and 2703 Transmission Control Units. They are performed only for BSC and start-stop devices and enable these devices to communicate with non-SNA application programs. NCP performs emulation functions through the Partitioned Emulation Program (PEP). EP standalone can be used to perform emulation functions without NCP.

TYPGEN specifies whether you are generating NCP under an MVS, VM, or VSE operating system. The default for TYPGEN is the operating system used to generate NCP.

VERSION specifies which NCP version and release is to be generated and whether NCP is to include support for the 3746 Model 900 connectivity subsystem.<sup>1</sup> VERSION is also used to specify the EP standalone release.

**Migrating to NCP V7R8:** Code TVERSION=V7R8 to generate NCP V7R8 without support for the 3746 Model 900. Code TVERSION=V7R8F to generate NCP V7R8 with support for the 3746 Model 900. To include 3746 Model 900 support, you need to obtain a license for the NCP 3746 Model 900 Feature from IBM.

<sup>1</sup> See "NCP V7R2, NCP V7R3, NCP V7R4, NCP V7R5, NCP V7R6, NCP V7R7, NCP V7R8" on page xxx for a description of the NCP Feature for 3746 Model 900 support, and see "3746 Model 900 Connectivity Subsystem" on page 3-6 for more information on the 3746 Model 900.

## Dynamically Created Control Blocks

### Sample Coding to Define the NCP Environment

Figure 2-6 shows how to define NCP V7R8 with 3746 Model 900 connectivity sub-system support. The NCP is assigned a subarea address of 310 in the local network (NETA) and supports a maximum of 120 network names.

```
A31NCP  BUILD  LOADLIB=NCPLoad,          *
          NAMTAB=120,                    *
          NETID=NETA,                     NETA is the native network name *
          NEWNAME=A31NCP,                *
          SUBAREA=310,                   Subarea address assigned to NCP *
          TYPGEN=NCP,                    *
          TYP SYS=MVS,                    *
          VERSION=V7R8F,                  *
          .                                *
          .                                *
          .                                *
```

Figure 2-6. Example: Defining the NCP Environment

## Dynamically Created Control Blocks

NCP can dynamically increase its control block resources<sup>2</sup> beyond the number defined in your generation definition to meet unexpected high demand. When you enable this function, NCP creates additional resources when needed using buffer pool storage. For example, if you specify NUMBER=25 on the PUDRPOOL definition statement, NCP dynamically creates the resources needed for a 26th physical unit added through dynamic reconfiguration.

**Note:** Using these dynamically created resources can degrade NCP performance, so it is recommended that you define all the resources you expect to need in your generation definition and use this function only to handle unexpected demand.

NCP can dynamically create resources to supplement the resources defined by the following keywords:

- Logical unit session resources:
  - ADDSESS on the BUILD definition statement
  - AUXADDR on the BUILD definition statement
  - NUMILU on the LUDRPOOL definition statement
- Cross-network session resources:
  - HSBPOOL on the BUILD definition statement
  - NUMADDR on the GWNAU definition statement
- Logical unit resources for dynamic reconfiguration:
  - NUMILU on the LUDRPOOL definition statement
  - NUMTYP1 on the LUDRPOOL definition statement
  - NUMTYP2 on the LUDRPOOL definition statement
- Physical unit resources for dynamic reconfiguration:
  - NUMBER on the PUDRPOOL definition statement

<sup>2</sup> In this section, the term *control block* refers to both control blocks and table entries unless otherwise indicated.

- Backup logical unit resources for the extended recovery facility (XRF):
  - BACKUP on the BUILD definition statement
- Network names table resources:
  - NAMTAB on the BUILD definition statement
- Session accounting resources:
  - GWSESAC on the BUILD definition statement
  - SESSACC on the BUILD definition statement
- Internet routing resources:
  - NUMROUTE on the IPOWNER definition statement
- Frame-Relay IP resources:
  - NUMDRIF on the IPOWNER definition statement

For a complete list of the control blocks NCP can create dynamically and the keywords that define them, refer to *NCP and EP Reference*.

When NCP dynamically adds the first resource of a particular type, NCP issues a generic alert to inform you that all the predefined resources of that type have been exhausted. The alert also tells you which keyword value to increase to define more of these resources in your generation definition. NCP also issues a generic alert when a resource of a particular type cannot be dynamically added.

Code the following definition statements and keywords to enable dynamic creation of NCP resources.

BUILD	BFRS
	DYNNSC
	DYNNSX
	DYNPOOL

BFRS on the BUILD definition statement defines the size of the buffers in the NCP buffer pool. When you specify a nonzero value for DYNPOOL, the minimum buffer size is 128. For more information about coding the BFRS keyword, see Chapter 24, “Network Performance” on page 24-1.

DYNNSC specifies the maximum number of NPM session counter control blocks (NSCs) NCP can create dynamically.

DYNNSX specifies the maximum number of NSC extensions NCP can create dynamically.

**Note:** DYNNSC and DYNNSX are valid only when your NCP includes session accounting or gateway session accounting. See “Session Accounting” on page 24-15 and “Defining Gateway Session Accounting and Accounting Exit Routines” on page 14-24 for more information.

DYNPOOL specifies what percentage of the NCP buffer pool can be used for dynamically created resources. Code DYNPOOL=0 or omit DYNPOOL to disable this function.

## Automatic Line Generation

DYNPOOL also defines the dynamic resource alert threshold. When the amount of buffer storage used for dynamically created resources exceeds this threshold, NCP issues a generic alert. You can use this alert to indicate when the buffer storage available for dynamically created resources is nearly depleted.

**Note:** To receive this alert, you need to configure the NetView program to display *impending problem* alerts.

---

## Automatic Line Generation

Automatic line generation simplifies coding for large networks with similar lines by copying a line definition structure a specified number of times. The line structure for BSC and start-stop lines can include CLUSTER, TERMINAL, and COMP definition statements. The line structure for SDLC lines can include PU and LU definition statements. The line structure cannot include GROUP, NETWORK, or GENEND definition statements.

The following sections describe the two methods available for generating line definitions automatically, the autocopy and autoline functions.

## Autocopy Function

The autocopy function is a method of automatic line generation designed to enable you to control the resource labels. You can code a LINE definition statement and its associated resources and specify the number of copies you want to create. During the generation process, NDF creates the number of copies of this line structure defined by the AUTOCOPY keyword. If you use AUTOCOPY, code NEWDEFN to build a new generation definition.

Code the following definition statements and keywords to provide NCP with information about how many times to repeat the line structure, the label used on the first LINE definition statement, and whether the numeric portion of the label to be incremented is decimal or hexadecimal.

LINE	AUTOCOPY
CLUSTER	NEXT
PU	NEXT
LU	NEXT
TERMINAL	NEXT
COMP	NEXT
ENDAUTO	

AUTOCOPY on the LINE definition statement is coded once to define a line that becomes the prototype for successively generated line definitions. The format of the label name on the LINE definition statement and the format of the label name on the AUTOCOPY suboperand must be the same. The label format must contain a numeric portion that can appear anywhere within the label. Successive LINE

definition statements use the same label format. For each new copy of the LINE definition statement, NDF increments the ADDRESS value by one and the numeric portion of the label by the difference between the numeric portion of the label on the LINE definition statement and the numeric portion of the AUTOCOPY or NEXT keyword value. This automatically creates a unique label for each LINE definition statement generated.

For example, if you code:

```
LN10A   LINE   ADDRESS=(10,FULL),AUTOCOPY=(10,LN12A),...
```

the difference between the numeric portion of the label and the numeric portion of the AUTOCOPY value is 2, so NDF increments the numeric portion of the label of each successive copy by 2:

```
LN12A   PU     ADDRESS=(11,FULL),...
```

NEXT on the CLUSTER, PU, LU, TERMINAL, and COMP definition statements defines the format of the label for the first copy of the definition statement and shows whether the portion of the label to be incremented is decimal or hexadecimal. The value coded on NEXT establishes the format for the label to be coded on the successive CLUSTER, PU, LU, TERMINAL, or COMP definition statements.

Be careful not to code labels and AUTOCOPY or NEXT values that generate labels longer than 8 characters. Also, if the portion of the label to be incremented is in hexadecimal and appears at the beginning of the label, be careful that no automatically generated label begins with a numeral. For example, if you make six copies of the following definition statement:

```
ALU     LU     NEXT=(BLU,H)...
```

the label for the last copy is 10LU, which is invalid. See *NCP, SSP, and EP Resource Definition Reference* for restrictions on labeling conventions.

Code the ENDAUTO definition statement to terminate the autocopy function.

The autocopy function differs from the autoline function in the following ways:

- You can define Token-Ring peripheral resources.
- You do not need to code the line address value in the labels of the definition statements to be copied. The AUTOCOPY keyword, unlike AUTOLINE, can be used to produce resources with user-specified labels.
- The labels created for all the resources on the LINE definition statement (CLUSTER, PU, LU, TERMINAL, and COMP definition statements) are completely independent of the LINE definition statement. Each label is generated separately.
- The numeric portion of the label can be decimal or hexadecimal.

Do **not** use AUTOCOPY:

- With spare or redefinable lines
- With a service order table
- When you use AUTOLINE on the same line structure
- When the UACB keyword appears on a LINE definition statement (this would result in the same adapter control block being specified for more than one line,

## Automatic Line Generation

which is not permitted; if you omit the UACB keyword, NDF automatically generates a unique adapter control block for each line)

- When you specify a physical channel position rather than the logical address (the autocopy function can be used with channels if a logical address is specified)
- With Ethernet-type LAN resources
- With Token-Ring subarea lines
- With NTRI frame handler logical lines
- With frame-relay physical lines
- With ISDN physical lines
- With NRF lines
- When you specify NCST on the GROUP definition statement.

**Note:** During automatic line generation for the autocopy function, NDF might use the storage manager work data set (DBWORKFL for MVS and VM); therefore, you might need to increase the size of the DBWORKFL data set to enable it to hold this large file. Refer to *NCP, SSP, and EP Generation and Loading Guide* for more information about the size of this data set.

### Sample Coding for the Autocopy Function

If you code the AUTOCOPY keyword in the generation definition shown in Figure 2-7, NDF generates the NEWDEFN file shown in Figure 2-8 on page 2-15.

```
A04L000 LINE ADDRESS=(000,FULL),AUTOCOPY=(2,A04L001),
      .
      .
      .
AP0001 PU ADDR=C1,NEXT=AP0011, * T2.0 DLU *
      .
      .
      .
AT0001A LU LOCADDR=1,PACING=7,ISTATUS=INACTIVE,NEXT=AT0011A
AT0001B LU LOCADDR=2,PACING=7,ISTATUS=INACTIVE,NEXT=AT0003B
AT0001C LU LOCADDR=3,PACING=7,ISTATUS=INACTIVE,NEXT=AT1001C
AP0002 PU ADDR=C2,NEXT=AP0042, * T2.0 DLU *
      .
      .
      .
AT0002A LU LOCADDR=1,PACING=7,ISTATUS=INACTIVE,NEXT=AT0012A
AT0002B LU LOCADDR=2,PACING=7,ISTATUS=INACTIVE,NEXT=AT0004B
AT0002C LU LOCADDR=3,PACING=7,ISTATUS=INACTIVE,NEXT=AT0222C
      ENDAUTO
```

Figure 2-7. Example: Defining the Autocopy Function



```

A04L000 LINE ADDRESS=(000,FULL),AUTOCOPY=(2,A04L001,DONE),
.
.
.
AP0001 PU ADDR=C1,NEXT=AP0011, * T2.0 DLU *
.
.
.
AT0001A LU LOCADDR=1,PACING=7,ISTATUS=INACTIVE,NEXT=AT0011A
AT0001B LU LOCADDR=2,PACING=7,ISTATUS=INACTIVE,NEXT=AT0003B
AT0001C LU LOCADDR=3,PACING=7,ISTATUS=INACTIVE,NEXT=AT1001C
AP0002 PU ADDR=C2,NEXT=AP0042, * T2.0 DLU
.
.
.
AT0002A LU LOCADDR=1,PACING=7,ISTATUS=INACTIVE,NEXT=AT0012A
AT0002B LU LOCADDR=2,PACING=7,ISTATUS=INACTIVE,NEXT=AT0004B
AT0002C LU LOCADDR=3,PACING=7,ISTATUS=INACTIVE,NEXT=AT0222C
ENDAUTO
*
A04L001 LINE ADDRESS=(1,FULL),AUTOCOPY=(2,A04L001,DONE),
.
.
.
AP0011 PU ADDR=C1,NEXT=AP0011, * T2.0 DLU *
.
.
.
AT0011A LU LOCADDR=1,PACING=7,ISTATUS=INACTIVE,NEXT=AT0011A
AT0003B LU LOCADDR=2,PACING=7,ISTATUS=INACTIVE,NEXT=AT0003B
AT1001C LU LOCADDR=3,PACING=7,ISTATUS=INACTIVE,NEXT=AT1001C
AP0042 PU ADDR=C2,NEXT=AP0042, * T2.0 DLU *
.
.
.
AT0012A LU LOCADDR=1,PACING=7,ISTATUS=INACTIVE,NEXT=AT0012A
AT0004B LU LOCADDR=2,PACING=7,ISTATUS=INACTIVE,NEXT=AT0004B
AT0222C LU LOCADDR=3,PACING=7,ISTATUS=INACTIVE,NEXT=AT0222C
A04L002 LINE ADDRESS=(2,FULL),AUTOCOPY=(2,A04L001,DONE),
AP0021 PU ADDR=C1,NEXT=AP0011, * T2.0 DLU *
.
.
.
AT0021A LU LOCADDR=1,PACING=7,ISTATUS=INACTIVE,NEXT=AT0011A
AT0005B LU LOCADDR=3,PACING=7,ISTATUS=INACTIVE,NEXT=AT0003B
AT2001C LU LOCADDR=3,PACING=7,ISTATUS=INACTIVE,NEXT=AT1001C
AP0082 PU ADDR=C2,NEXT=AP0042, * T2.0 DLU *
.
.
.
AT0022A LU LOCADDR=1,PACING=7,ISTATUS=INACTIVE,NEXT=AT0012A
AT0006B LU LOCADDR=2,PACING=7,ISTATUS=INACTIVE,NEXT=AT0004B
AT0442C LU LOCADDR=3,PACING=7,ISTATUS=INACTIVE,NEXT=AT0222C

```

Figure 2-8. Example: NEWDEFN File Created by the Autocopy Function

### Autoline Function

The autoline function is similar to the autocopy function described in “Autocopy Function” on page 2-12. The autoline function is an alternative method of automatic line generation. With the autoline function, you specify the beginning line address and the range of line addresses in the generation definition. NDF repeats the line structure for the specified range and automatically increments each line address. If you use automatic line generation, code NEWDEFN to build a new generation definition.

**Note:** GROUP, NETWORK, and GENEND definition statements cannot be included in the statements to be replicated.

Code the following definition statements and keywords to provide NCP with information about how to generate successively incremented line addresses in the system generation definition.

LINE	ADDRESS
	AUTOLINE
ENDAUTO	

ADDRESS on the LINE definition statement specifies the beginning address for automatically generated lines.

AUTOLINE specifies the end of the address range of the automatically generated lines.

ENDAUTO is the end delimiter for the statements to be replicated.

Do **not** code AUTOLINE:

- With spare or redefinable lines
- When you specify channel positions for PEP
- With a multipoint line
- When you code ADDRESS=NONE or when you specify AUTO or ID on the LINE definition statement
- With a service order table
- With Ethernet-type LAN resources
- When you code ECLTYPE on the GROUP definition statement
- When you code FRELAY on the GROUP definition statement
- When you code NCST on the GROUP definition statement
- When you code ISDN on the GROUP definition statement
- When you define ESCON or 3746 Model 900 Token-Ring adapters.

When you use the autoline function, the numeric line address must be part of the labels of the LINE, CLUSTER, TERMINAL, PU, and LU definition statements. NDF uses this label naming convention to create a unique label for each statement.

You can embed the numeric line address anywhere within the label so that the generated labels are compatible with existing naming conventions. If the address appears more than once in a label, only the first occurrence of the address is used or modified. Be careful that the automatic labeling convention does not create labels longer than 8 characters. See *NCP, SSP, and EP Resource Definition Reference* for restrictions on labeling conventions.

### Sample Coding for the Autoline Function

If you code the example in Figure 2-9, NDF generates the sample NEWDEFN file in Figure 2-10.

```

        OPTIONS  NEWDEFN=(YES,ECHO)
        .
        .
        LN32A   LINE   ADDRESS=32,AUTOLINE=40,KEY1=VAL1,
                KEY2=VAL2           This is a comment that will
PU32A1  PU   KEY1=VAL1,KEY2=VAL2   also be replicated
LU32A1A LU   KEY1=VAL1,KEY2=VAL2
LU32A1B LU   KEY1=VAL1,KEY2=VAL2
LU32A2  PU   KEY1=VAL1,KEY2=VAL2
LU32A2A LU   KEY1=VAL1,KEY2=VAL2
LU32A2B LU   KEY1=VAL1,KEY2=VAL2
LU32A2C LU   KEY1=VAL1,KEY2=VAL2
        ENDAUTO

```

Figure 2-9. Example: Defining the Autoline Function

## Migration Aid Function

```
LN32A    LINE    ADDRESS=32,AUTOLINE=(40,DONE),KEY1=VAL1,
          KEY2=VAL2          This is a comment that will
PU32A1   PU      KEY1=VAL1,KEY2=VAL2    also be replicated
LU32A1A  LU      KEY1=VAL1,KEY2=VAL2
LU32A1B  LU      KEY1=VAL1,KEY2=VAL2
LU32A2   PU      KEY1=VAL1,KEY2=VAL2
LU32A2A  LU      KEY1=VAL1,KEY2=VAL2
LU32A2B  LU      KEY1=VAL1,KEY2=VAL2
LU32A2C  LU      KEY1=VAL1,KEY2=VAL2
LN33A    LINE    ADDRESS=33,AUTOLINE=(40,DONE),KEY1=VAL1,
          KEY2=VAL2          This is a comment that will
PU33A1   PU      KEY1=VAL1,KEY2=VAL2    also be replicated
LU33A1A  LU      KEY1=VAL1,KEY2=VAL2
LU33A1B  LU      KEY1=VAL1,KEY2=VAL2
LU33A2   PU      KEY1=VAL1,KEY2=VAL2
LU33A2A  LU      KEY1=VAL1,KEY2=VAL2
LU33A2B  LU      KEY1=VAL1,KEY2=VAL2
LU33A2C  LU      KEY1=VAL1,KEY2=VAL2
.
.
.
LN40A    LINE    ADDRESS=40,AUTOLINE=(40,DONE),KEY1=VAL1,
          KEY2=VAL2          This is a comment that will
PU40A1   PU      KEY1=VAL1,KEY2=VAL2    also be replicated
LU40A1A  LU      KEY1=VAL1,KEY2=VAL2
LU40A1B  LU      KEY1=VAL1,KEY2=VAL2
LU40A2   PU      KEY1=VAL1,KEY2=VAL2
LU40A2A  LU      KEY1=VAL1,KEY2=VAL2
LU40A2B  LU      KEY1=VAL1,KEY2=VAL2
LU40A2C  LU      KEY1=VAL1,KEY2=VAL2
          ENDAUTO
```

Figure 2-10. Example: NEWDEFN File Created by the Autoline Function

## Migration Aid Function

The migration aid is a function of NDF that automates much of the NCP migration task. The migration aid function helps you migrate a generation definition to a different NCP version (the *target version*) or communication controller model (the *target model*).

The migration aid function uses an NCP generation definition for an IBM 3705, 3720, 3725, or 3745 Communication Controller as input. The migration aid function converts the generation definition to define NCP V7R8 for an IBM 3745 Communication Controller and writes it to a NEWDEFN file.

The migration aid can also be used to migrate an EP standalone generation definition to an EP R14 standalone gen.

You can invoke the migration aid function either by coding TMODEL, TUSGTIER, and TVERSION on the OPTIONS definition statement or by coding the equivalent parameters on the NDF statement in the JCL or VM EXEC for your NDF generation job. See *NCP V7R8 Migration Guide* for a detailed description of the migration aid function and for more information on the NDF procedure.

Code the following definition statement and keywords to provide NCP with information about the communication controller model number, the usage tier, and the version of NCP.

OPTIONS	DPU
	NERLIM
	SAVEADDR
	TMODEL
	TUSGTIER
	TVERSION

DPU on the OPTIONS definition statement specifies whether NDF accepts the default values of keywords that define the dynamic path update function, thereby adding the function to NCP. When you permit dynamic path update keywords to default, it can cause a significant amount of storage to be allocated for dynamic path update even if you do not use the function. Code DPU=NO to suppress the dynamic path update function.

NERLIM specifies a value for the ERLIMIT keyword to be added to each NETWORK definition statement on which ERLIMIT is not specified.

SAVEADDR specifies whether hardware-specific addresses in the input generation definition are to be preserved. Code SAVEADDR=YES to carry forward the values specified for the ADDRESS, AUTO, DUALCOM, DYNADMP, HICHAN, and LOCHAN keywords on the BUILD or LINE definition statement in the generation definition. Code SAVEADDR=NO if your configuration does not use the same addresses.

TMODEL specifies the controller model number.

TUSGTIER sets the usage tier for your controller. Your system engineer can determine the usage tier value from the IBM HONE Configurator hardware configuration output report (CF37xx Report).

TVERSION specifies which NCP version and release you are migrating to and whether the new NCP is to include support for the 3746 Model 900 connectivity subsystem.<sup>3</sup> TVERSION also specifies the EP release you are migrating to for EP standalone.

**Migrating to NCP V7R8:** Code VERSION=V7R8 to migrate to NCP V7R8 without support for the 3746 Model 900. Code VERSION=V7R8F to migrate to NCP V7R8 with support for the 3746 Model 900. To include 3746 Model 900 support, you need to obtain a license for the NCP 3746 Model 900 Feature from IBM.

**Migrating to EP R14 standalone:** Code TVERSION=V1R14.

<sup>3</sup> See "NCP V7R2, NCP V7R3, NCP V7R4, NCP V7R5, NCP V7R6, NCP V7R7, NCP V7R8" on page xxx for a description of the NCP Feature for 3746 Model 900 support, and see "3746 Model 900 Connectivity Subsystem" on page 3-6 for more information on the 3746 Model 900.



---

## Chapter 3. Defining Your Communication Controller

NCP runs in the IBM 3745 Communication Controller. The IBM 3745 is a programmable, modular communication controller that offers a high degree of flexibility in network configuration. It can be channel-attached to one or more hosts, or link-attached through another IBM communication controller. It runs in a partitioned emulation program (PEP) or EP standalone (EPSA) environment to support non-SNA requirements. PEP enables NCP and the Emulation Program (EP) to coexist in an IBM 3745 Communication Controller. EPSA runs EP independent of NCP, with no access to NCP resources. For information about the definition statements for EPSA, see Chapter 21.

In this book, information about the IBM 3745 Communication Controller applies to all 3745 models unless the text specifically notes a difference. Before you attempt to define your IBM 3745 Communication Controller model, you should be aware of the following special features:

- The IBM 3745-410, 3745-41A, 3745-610, and 3745-61A models have two CCUs, each capable of running a separate NCP load module.
- The IBM 3745-17A, 3745-21A, 3745-31A, 3745-41A, and 3745-61A models have the following features:
  - They support the optional 3746 Model 900 connectivity subsystem, which performs NCP data link control functions for SDLC, Token-Ring, frame-relay, ISDN, and ESCON connections.
  - They always have a Personal System/2 (PS/2) workstation with the maintenance and operator subsystem extended (MOSS-E) as the service processor.
- The IBM 3745-31A and 3745-61A can be configured with 16 megabytes (MB) of CCU memory (if the proper storage control card is installed).

This chapter describes how to define the communication controller in which your NCP resides. See *NCP, SSP, and EP Resource Definition Reference* for more information about the generation of NCP load modules.

---

### Defining an IBM 3745 Communication Controller

Code the following definition statement and keywords to provide NCP with information about the amount of controller storage, the model you are using, and the appropriate usage tier.

BUILD	CSSTIER
	MEMSIZE
	MODEL
	USGTIER

## Fallback and Switchback

CSSTIER specifies the usage tier for 3746 Model 900 connectivity subsystem support.<sup>1</sup> The usage tier determines how many connectivity subsystem adapters you can attach to the 3746 Model 900. To determine which CSS tier you can specify, refer to the information from the appropriate Configurator Aid, CFPROGS, CF3745, or CSFW.

MEMSIZE on the BUILD definition statement specifies how much controller storage NCP or EP can use for the load module, control blocks, and data buffers. It is recommended that you omit MEMSIZE; this enables NCP to use all the storage in your controller. If you code MEMSIZE, be sure to determine how much storage your NCP requires.

MODEL identifies the communication controller model in which your NCP resides.

USGTIER specifies the usage tier for your NCP. The usage tier determines how many scanners, channel adapters, Token-Ring adapters, and Ethernet-type subsystem (ESS) adapters you can attach to your controller. To determine which usage tier you can specify, refer to the information from the appropriate Configurator Aid, CFPROGS, CF3745, or CSFW.

For the IBM 3745-410, 3745-41A, 3745-610, or 3745-61A controllers, USGTIER also indicates whether the controller will operate in the single, twin-in-dual, twin-in-standby, or twin-in-backup hardware configuration. Twin-in-standby and twin-in-backup modes support the fallback function.

### Sample Definition of a Communication Controller

Figure 3-1 shows you how to define an IBM 3745 Communication Controller and the attached channel adapter.

```
A31NCP  BUILD MODEL=3745,          *
          USGTIER=5,                *
          .
          .
A31CAG1  GROUP CA=TYPE7,           Identify type 7 channel adapter *
          .
          .
```

Figure 3-1. Example: Defining a Communication Controller

---

## Fallback and Switchback

The IBM 3745-410, 3745-41A, 3745-610, and 3745-61A Communication Controllers provide a twin-CCU configuration. This configuration operates in one of the following three modes:

- Twin-in-dual
- Twin-in-standby
- Twin-in-backup.

---

<sup>1</sup> See “NCP V7R2, NCP V7R3, NCP V7R4, NCP V7R5, NCP V7R6, NCP V7R7, NCP V7R8” on page xxx for a description of the NCP Feature for 3746 Model 900 support, and see “3746 Model 900 Connectivity Subsystem” on page 3-6 for more information on the 3746 Model 900.



In *twin-in-dual mode*, two NCPs are running independently; each NCP runs in a CCU with permanently attached buses in the controller. In *twin-in-standby mode*, two identical NCPs are present in the controller; one is in the active CCU and the other is in the standby CCU. All of the buses are attached to the active CCU. In *twin-in-backup mode*, two NCPs are running independently in the two CCUs, and each can act as backup for the other. There are two buses for each CCU.

Figure 3-2, Figure 3-3, and Figure 3-4 show the bus switching capabilities of each mode of an IBM 3745-410, 3745-41A, 3745-610, or 3745-61A Communication Controller. Figure 3-2 illustrates a configuration operating in twin-in-dual mode where no switching is permitted.

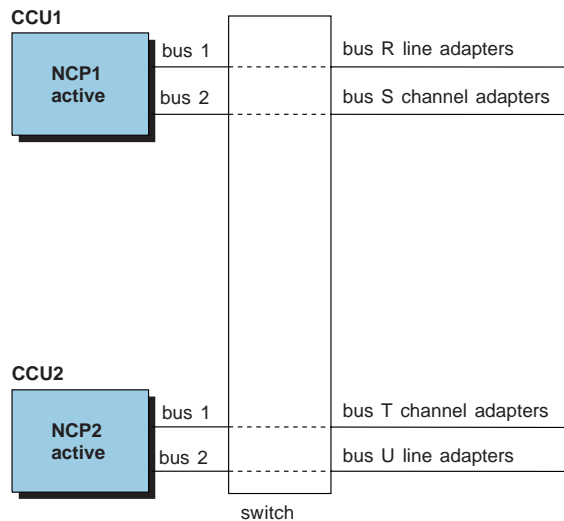

Figure 3-2. IBM 3745-410, 3745-41A, 3745-610, or 3745-61A in Twin-in-Dual Mode

IBM 3745-410, 3745-41A, 3745-610, and 3745-61A Communication Controllers in twin-in-dual CCU mode do not preserve communication flow if a CCU fails. Through a function called *fallback*, however, an IBM 3745-410, 3745-41A, 3745-610, or 3745-61A in twin-in-standby or twin-in-backup mode can recover the path of communication flow if one of the CCUs fails. Fallback is the process by which an IBM 3745-410, 3745-41A, 3745-610, or 3745-61A switches buses from the failing CCU to the fallback CCU. In both modes, MOSS first notices that an active CCU failed and then begins fallback.

For additional information, review *IBM 3745 Communication Controller Introduction* to familiarize yourself with an IBM 3745-410, 3745-41A, 3745-610, or 3745-61A configuration. See “3746 Model 900 Connectivity Subsystem” on page 3-6 for information about fallback and switchback that relates to 3746 Model 900 connectivity subsystem resources.

## Fallback for NCP

When the IBM 3745-410, 3745-41A, 3745-610, or 3745-61A is configured in twin-in-standby mode, one NCP is in the active CCU and the other NCP is in the standby CCU. Figure 3-3 on page 3-4 shows that the NCP in the active CCU controls all the line and channel adapters. In twin-in-standby mode, the fallback function switches all line and channel adapter buses from the failing NCP on CCU1 to the NCP on CCU2. Because the adapters are never connected to both CCUs at the

## Fallback and Switchback

same time, you can load the same NCP load module into CCU1 and CCU2. In this situation, you need only one generation definition.

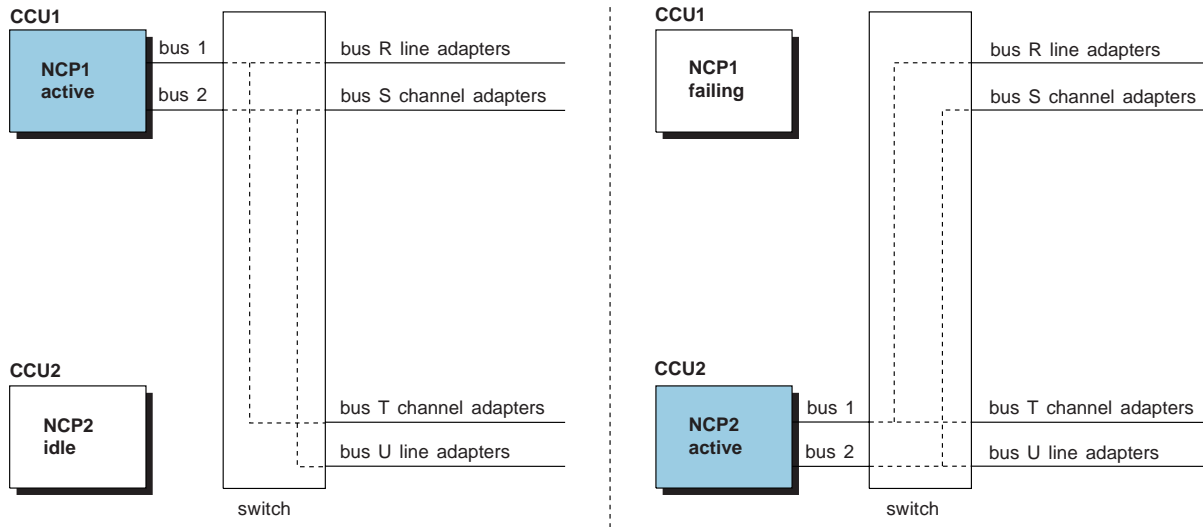

Figure 3-3. IBM 3745-410, 3745-41A, 3745-610, or 3745-61A in Twin-in-Standby Mode

When configured in twin-in-backup mode, each NCP can be active and control part of the network (Figure 3-4). If CCU1 fails in twin-in-backup mode, the adapters on buses connected to CCU1 switch to the already operating CCU2 running NCP 2.

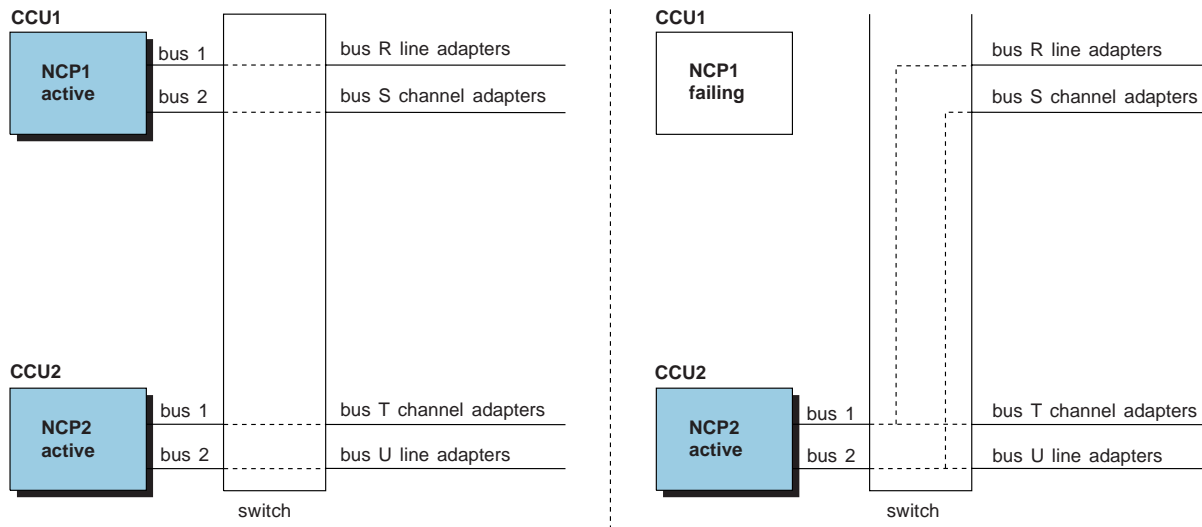

Figure 3-4. IBM 3745-410, 3745-41A, 3745-610, or 3745-61A in Twin-in-Backup Mode

Because both NCPs are active, two generation definitions, two load modules, and two subareas are present. Carefully coordinate the definition statements and keywords coded in the two generation definitions to allow for fallback in twin-in-backup mode. For example, on the line adapter that you want to be able to switch to in case of CCU failure using twin-in-backup mode:

- Define the lines attached to that adapter in the generation definition for both NCPs.

- Give the lines and their associated physical units different names in each NCP generation definition.
- Give the associated logical units the same name in each NCP generation definition.
- Define the channel adapter that you want to be able to switch to the backup NCP only if the host attached to that channel adapter is not already defined and attached to the backup NCP.

If there is no other channel adapter that the host can use to communicate with the backup NCP and you do not define one for the backup NCP, at fallback the host will not be able to reactivate its sessions with the switched resources. Sessions originally held by the backup NCP should not be affected by a fallback operation.

### Fallback for EP (PEP only)

The fallback capability on the IBM 3745-410, 3745-41A, 3745-610, or 3745-61A Communication Controller changes the way you define resources for EP. If you defined resources for other controller models and they were not present, the load module would fail. To use fallback, you must define backup resources so that the necessary control blocks will be resident in case of a fallback. However, the control blocks for backup resources are initialized only when a fallback actually occurs.

The corresponding control blocks in the NCP in the active CCU, which actually owns the resources, are initialized when the NCP is loaded. Only adapters that are installed, attached, and operative are initialized during the load process.

All EP resources defined for fallback must be complementary. For example, lines defined on a fallback channel adapter must be for a fallback line adapter, and lines defined on an owned channel adapter must be for an owned line adapter. This is necessary because each EP line is associated with a specific emulator subchannel, and both must be available to provide a valid configuration. All MSLA subchannels defined for a line must reside in the same NCP as that line.

Predefined resources must also be complementary, if, for example, you define emulation mode subchannels or lines because you are planning later installation of a new channel line adapter. The channel adapter must reside on the same CCU as the line adapter. The definitions cannot be split across CCU boundaries.

### Switchback

When the failed CCU in an IBM 3745-410, 3745-41A, 3745-610, or 3745-61A in twin-in-backup mode is repaired, or the NCP is re-IPLed, you can switch those buses originally operated by the failed CCU from the backup CCU. This process is called *switchback*. In Figure 3-4 on page 3-4, for example, you can switch buses R and S back to the NCP running on CCU1. Follow these steps, which work for all circumstances, to initiate switchback:

1. Deactivate all the lines on line adapter bus R connected to CCU2.
2. Issue a channel discontact to all the channel adapters on bus S attached to CCU2.
3. Request switchback from the maintenance or customer menu of the MOSS console.
4. Reactivate all the NCP1-owned resources on CCU1 when switchback is complete.

## 3746 Model 900 Connectivity Subsystem

### Notes:

1. You can skip steps 1 and 2 when you request a *switchback-forced* from the maintenance or customer menu on the MOSS console. All active lines and channels will be automatically deactivated.
2. You do not need to deactivate 3746 Model 900 resources on CCU2 for a switchback if they will not be activated on CCU1.

## Fallback and Switchback for IBM Special Products or User-Written Code

When switchback is requested, NCP checks lines with NCP-compatible control blocks, and verifies that resources on NCP lines and those lines belonging to IBM special products or user-written code are not active. Lines that do not have NCP-compatible control blocks are not checked. Refer to *NCP, SSP, and EP Resource Definition Reference* for complete coding details.

Code the following definition statement and keywords to provide NCP with information about control blocks used by IBM special products or user-written code.

GROUP	COMPOWN COMPTAD
-------	--------------------

COMPOWN on the GROUP definition statement causes NCP to verify that adapter control blocks for the lines in this group either have been freed by any SSCP owners or must be deactivated when switchback occurs.

COMPTAD determines whether the control block structure of a line group belonging to IBM special products or user-written code is compatible with NCP control block structure for initialization, updating of the configuration data set, and bus switching. See *NCP and SSP Customization Guide* for further information on these keywords.

---

## 3746 Model 900 Connectivity Subsystem

The 3746 Model 900 connectivity subsystem (CSS) is attached to the IBM 3745 to support connections to the following resources:<sup>2</sup>

- Enterprise Systems Connection (ESCON) links (See “Defining ESCON Links” on page 4-9.)
- 3746 Model 900 SDLC links (See Chapter 5.)
- 3746 Model 900 frame-relay links (See “3746 Model 900 Frame Relay” on page 16-72.)
- 3746 Model 900 Token-Ring links (See Chapter 6.)
- 3746 Model 900 X.25 links (See *NCP Version 7 and X.25 NPSI Version 3 Planning and Installation*.)
- 3746 Model 900 ISDN links (See Chapter 7.)

---

<sup>2</sup> To use the 3746 Model 900, you need to obtain a license for the NCP 3746 Model 900 Feature from IBM. See “NCP V7R2, NCP V7R3, NCP V7R4, NCP V7R5, NCP V7R6, NCP V7R7, NCP V7R8” on page xxx for more information on the NCP 3746 Model 900 Feature.

The following sections describe special considerations for 3746 Model 900 resources that are supported by an IBM 3745-41A or 3745-61A operating in twin-in-dual or twin-in-backup mode.

## Shared 3746 Model 900 Resources between Two NCPs

When an IBM 3745-41A or 3745-61A operates in twin-in-dual or twin-in-backup mode, two NCPs may attempt to activate the same 3746 Model 900 ESCON, SDLC, Token-Ring, frame-relay, ISDN, or X.25 resources shared by the two NCPs. However, depending on the resource type and the circumstances, only one NCP may be allowed to activate a 3746 Model 900 resource at a time. The following sections describe shared 3746 Model 900 resources and contention for shared resources.

### Shared ESCON Resources

ESCON physical and logical lines can be simultaneously activated by both NCPs in a twin-in-dual or twin-in-backup configuration; however, only one NCP can activate the logical link station. For example, in Figure 3-6 on page 3-9, each NCP can activate the same ESCON physical line (address 2240) and subsequently activate the associated ESCON logical line (host link 1). Contention occurs when both NCPs attempt to activate the logical link station with the device unit address of X'01' on that logical line.

### Shared 3746 Model 900 SDLC, Token-Ring, Frame-Relay, ISDN, and X.25 Resources

3746 Model 900 SDLC, Token-Ring, frame-relay, ISDN, and X.25 lines cannot be simultaneously activated by both NCPs in a twin-in-dual or twin-in-backup configuration. When one NCP operating in twin-in-dual or twin-in-backup mode activates one of these lines, the other NCP cannot activate the same line until it is released by the first NCP.

**Note:** Two NCPs in a twin-in-dual or twin-in-backup configuration can activate separate physical lines attached to the same 3746 Model 900 communication line adapter or 3746 Model 900 Token-Ring adapter.

## Shared 3746 Model 900 Resources between an NCP and 3746 Model 900

Logical resources activated by an NCP and logical resources activated by an 3746 Model 900 NN or IP control point can share the bandwidth of an ESCON, Token-Ring, frame-relay, or X.25 physical line when you specify the same line address in the NCP and the 3746 Model 900 definitions. Resources associated with an NCP and 3746 Model 900 can share an ESCON logical line when the NCP and 3746 Model 900 definitions specify the same ESCON subchannel number. An NCP and a 3746 Model 900 definition can also specify the same frame-relay DLCI. DLCIs can be shared only for peripheral traffic.

**Note:** Only a **nonswitched** physical line can be shared by an NCP and a 3746 Model 900.

When sharing the bandwidth of a physical line, you need to ensure that the line parameters, such as the speed of a frame-relay line, are equivalent in both the NCP and 3746 Model 900 definitions. If certain parameters do not match, an alert is forwarded to Netview, generally parameters from the first activation take precedent, and in some cases, link activation fails.

## Fallback and Switchback for 3746 Model 900 Resources

Because both NCPs operating in twin-in-backup mode have shared access to 3746 Model 900 resources, use the following guidelines to define and operate these resources:

- It is not necessary to switch a 3746 Model 900 resource back to the original NCP when performing switchback to a failed NCP that has been re-IPLed.
- When you define 3746 Model 900 resources for NCPs operating in twin-in-backup mode, only one NCP can use the SSCP monitor mode function (SMMF) to activate the physical line.

**Note:** If SMMF attempts to activate a resource that cannot be concurrently activated by both NCPs, an activation failure indication results when the restored NCP is activated.

See the descriptions of MONLINK on the LINE definition statement and XMONLNK on the PU definition statement in “ESCON Logical Lines” on page 4-14 and See “SSCP Monitor Mode Function” on page 5-12 for more information about how to use SMMF.

### Sample Definition of Fallback and Switchback for 3746 Model 900 Resources

Figure 3-5 shows an IBM Communication Controller with 3746 Model 900 attachments to two hosts. Two NCPs operate in twin-in-backup mode to support the fallback and switchback functions.

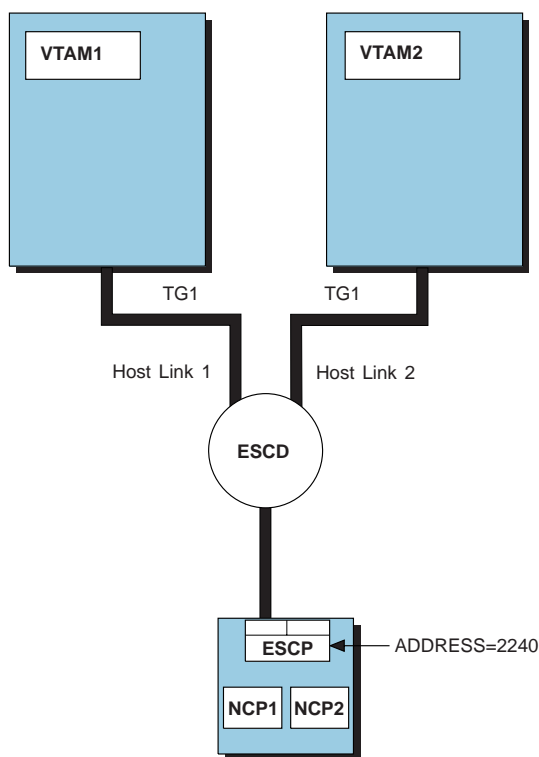

Figure 3-5. IBM Communication Controller in Twin-in-Backup Mode with 3746 Model 900 Resources

Figure 3-6 shows how to define the NCPs with 3746 Model 900 resources shown in Figure 3-5 on page 3-8. The NCPs are defined to support fallback and switchback.

<b>**** NCP1 DEFINITIONS ****</b>			<b>**** NCP2 DEFINITIONS ****</b>		
PCCU1	PCCU	BACKUP=YES, OWNER=VTAM1	PCCU1	PCCU	BACKUP=YES, OWNER=VTAM1
PCCU2	PCCU	BACKUP=YES, OWNER=VTAM2	PCCU2	PCCU	BACKUP=YES, OWNER=VTAM2
PCCUX	PCCU	BACKUP=YES, OWNER=VTAMX	PCCUX	PCCU	BACKUP=YES, OWNER=VTAMX
<b>*** ESCA PHYSICAL RESOURCE ***</b>			<b>*** ESCA PHYSICAL RESOURCE ***</b>		
APHYSGR	GROUP	LNCTL=CA	BPHYSGR	GROUP	LNCTL=CA
APLINE1	LINE	ADDRESS=2240, XMONLNK=YES, OWNER=VTAM1, ISTATUS=ACTIVE	BPLINE1	LINE	ADDRESS=2240, XMONLNK=YES, OWNER=VTAM2, ISTATUS=ACTIVE
APPU1	PU	PUTYPE=1	BPPU1	PU	PUTYPE=1
<b>*** ESCA LOGICAL RESOURCES ***</b>			<b>*** ESCA LOGICAL RESOURCES ***</b>		
ALOGGRP1	GROUP	LNCTL=CA, PHYSRSC=APPU1	BLOGGRP1	GROUP	LNCTL=CA, PHYSRSC=BPPU1
<b>**** ESCA LOGICAL LINE 1 ****</b>			<b>**** ESCA LOGICAL LINE 1 ****</b>		
ALLINE1	LINE	HOSTLINK=1, MONLINK=YES, OWNER=VTAM1, ISTATUS=ACTIVE	BLLINE1	LINE	HOSTLINK=1, MONLINK=NO, OWNER=VTAMX, ISTATUS=INACTIVE
ALL1PU1	PU	PUTYPE=5, ADDR=01	BLL1PU1	PU	PUTYPE=5, ADDR=01
<b>**** ESCA LOGICAL LINE 2 ****</b>			<b>**** ESCA LOGICAL LINE 2 ****</b>		
ALLINE2	LINE	HOSTLINK=2, MONLINK=NO, OWNER=VTAMX, ISTATUS=INACTIVE	BLLINE2	LINE	HOSTLINK=2, MONLINK=YES, OWNER=VTAM2, ISTATUS=ACTIVE
ALL2PU1	PU	PUTYPE=5, ADDR=02	BLL2PU1	PU	PUTYPE=5, ADDR=02

Figure 3-6. Example: Defining Fallback and Switchback for 3746 Model 900 Resources

## Usage Tiers

When you use usage tiers, you have more flexibility in selecting the optimal NCP. For the IBM 3745 Communication Controller, each usage tier defines the number of TRAs, ESS adapters, HPTSS and TSS line adapters, and channel adapters attached to your controllers. For the 3746 Model 900 connectivity subsystem, usage tiers define the maximum number of Token-Ring, ESCON, and communication line adapters that can be attached to the 3746 Model 900.

## Usage Tiers for the IBM 3745 Communication Controller

Table 3-1 shows the total number of adapters you can specify for each IBM 3745 usage tier. It also shows the maximum number of HPTSS line adapters you can specify for any one usage tier. This number should be considered a part of the total number of line adapters specified. For example, at usage tier 4 with no Token-Ring adapters, you can specify that 8 of the 24 line adapters are high speed.

The following abbreviations are used in this table and elsewhere in this book:

**ESS** Ethernet-type subsystem, that is, Ethernet adapter  
**HPTSS** high-speed scanner  
**TRA** Token-Ring adapter  
**TSS** low-speed scanner

Table 3-1. Usage Tier Definition

Usage Tier	TRA and ESS Adapters	HPTSS Adapters	Total HPTSS and TSS Adapters	Channel Adapters
1	1	1	1	2
	0	0	0	4
2	1	2	2	2
	0	0	0	6
2.5	0	6	6	4
	1 or 2	2	2	4
	0	0	0	8
3	0	8	8	8
	1 to 4	4	4	8
	0	0	0	16
4	0	8 <sup>1</sup>	24	16
	1 to 4	4 <sup>1</sup>	20	16
	5 to 8 <sup>2</sup>	4 <sup>1</sup>	16	16
5	0	8 <sup>1</sup>	32	16
	1 to 4	4 <sup>1</sup>	28	16
	5 to 8 <sup>2</sup>	4 <sup>1</sup>	24	16

<sup>1</sup> Hardware restrictions limit the number of high-speed adapters on the IBM 3745.

<sup>2</sup> Hardware restrictions limit the number of adapters on the IBM 3745-210 and 3745-410 to 4 TRA adapters (positions 1,2,5,6) and 8 ESS adapters (positions 1–8).

The usage tier implementation:

- Provides consistent implementation for all models of the IBM 3745 Communication Controller
- Provides unique error codes for usage tier problems
- Requires that the usage tier be specified in the generation definition
- Provides NCP flexibility in determining the set of supported line adapters.



NDF verifies that the specified usage tier supports the number of channel adapters, the number of Token-Ring line adapters, and the number of Ethernet line adapters required by your NCP definition.

### Usage Tier Generic Alerts

When an SSCP-PU session is started for an NCP for which the usage tier limit has been exceeded, NCP sends a generic alert to all current owners of the NCP. Any other owners will also receive a generic alert as long as the usage tier remains exceeded.

For information on the format of usage tier generic alerts, refer to *NCP and EP Reference Summary and Data Areas*, Volume 1.

### Other Considerations

The following considerations also apply to usage tiers:

- The Token-Ring variation of usage tiers 2.5 to 5 applies only when Token-Ring physical lines are defined by the NCP generation process.
- No specific usage tier is required to use any single channel adapter or line adapter position.
- Usage tier 1 does not support the IBM 3745 in any mode other than single or twin-in-standby.
- Usage tier supports half the number of channel and line adapters shown in Table 3-1 on page 3-10 on each CCU for an IBM 3745 in twin-in-dual or twin-in-backup mode. NDF can validate these configurations for channel adapters, Token-Ring adapters, and Ethernet adapters.
- If a usage tier exception occurs for a line adapter, you can use the NCP usage tier control block (UTS) to determine which line adapters usage tier supports. Refer to *NCP and EP Reference Summary and Data Areas*, Volume 1, for the control block layout and location.

## Usage Tiers for the 3746 Model 900

Table 3-2 shows the total number of adapters you can specify for 3746 Model 900 usage tiers. Tiers do not include Token-Ring processors to which couplers or the service processor are attached.

Table 3-2. Usage Tiers for the 3746 Model 900

Usage Tier	Maximum Number of Adapters
A	Any combination of up to 5 Token-Ring, ESCON, or communication line adapters
B	Any combination of 6 or more Token-Ring, ESCON, or communication line adapters
C <sup>1</sup>	Any combination of 6 or more Token-Ring, ESCON, or communication line adapters

<sup>1</sup> Usage tier C indicates that you have the no charge feature that is available with the network node hardware feature 5022 installed on your 3746 Model 900.



---

## Part 2. Defining NCP Resources

<b>Chapter 4. Channel Links and Access Methods</b> . . . . .	4-1
Defining System/370 I/O Channel Links . . . . .	4-1
Subarea Channel Links . . . . .	4-2
Peripheral Channel Links . . . . .	4-4
Migrating to a Type 7 Channel Adapter . . . . .	4-7
Loading and Dumping a Channel-Attached NCP . . . . .	4-7
Sample System/370 Channel Link Configuration and Definition . . . . .	4-8
Defining ESCON Links . . . . .	4-9
ESCON Generation Assistant . . . . .	4-12
ESCON Physical Lines . . . . .	4-13
ESCON Logical Lines . . . . .	4-14
Migrating a System/370 Channel Link to an ESCON Logical Line . . . . .	4-18
Using MOSS Extended to Configure ESCON Links . . . . .	4-22
Defining Subarea Addressing Limits . . . . .	4-26
Maximum Number of Concurrent Sessions and Routes . . . . .	4-27
Dynamic Control Facilities . . . . .	4-28
Defining NCP to VTAM . . . . .	4-29
<b>Chapter 5. NCP and Link-Attached Devices</b> . . . . .	5-1
Nonswitched Telecommunication Links . . . . .	5-1
Switched Links . . . . .	5-4
V.25 Bis . . . . .	5-7
Limited Resource Sessions . . . . .	5-10
Shared Port Identification . . . . .	5-11
SSCP Monitor Mode Function . . . . .	5-12
SMMF for Nonswitched SDLC Subarea Links . . . . .	5-12
SMMF for Switched SDLC Subarea Links . . . . .	5-13
SMMF for Nonswitched SDLC Peripheral Devices . . . . .	5-15
SMMF for Subarea Channel Links . . . . .	5-16
SMMF for ESCON Links . . . . .	5-17
Spare and Redefinable SDLC Lines . . . . .	5-19
Converting Existing SDLC Resources to 3746 Model 900 SDLC Resources . . . . .	5-21
Modems . . . . .	5-22
Channelized Modems . . . . .	5-23
Switched Network Backup . . . . .	5-25
Devices Attached to NCP . . . . .	5-26
BSC or Start-Stop Devices on Nonswitched Links . . . . .	5-26
BSC or TWX Devices Attached to Switched Links . . . . .	5-30
BSC Devices and VTAM . . . . .	5-33
SDLC Devices on Nonswitched Links . . . . .	5-33
SDLC Devices on Switched Links . . . . .	5-34
SDLC Devices and VTAM . . . . .	5-36
Maximum Number of Sessions to Maintain . . . . .	5-37
Polling and Addressing . . . . .	5-37
IBM 3174 Group Poll . . . . .	5-42
Data Characteristics . . . . .	5-43
End of Transmission . . . . .	5-45
Delay between Successive Transmissions for Buffered Devices . . . . .	5-46
<b>Chapter 6. Token-Ring Resources</b> . . . . .	6-1

Defining Token-Ring Resources	6-3
NDF-Generated Additions for Token-Ring Resources	6-4
Defining Token-Ring Physical Connections	6-6
Defining Backup Token-Ring Interface Couplers	6-15
Duplicate TIC Addressing	6-16
Defining Token-Ring Logical Connections	6-20
Unassigned Logical Line Pools	6-24
Defining Peripheral Device Addresses for VTAM	6-25
Sample Token-Ring Peripheral Resource Definitions	6-26
Token-Ring Subarea Links	6-27
Defining Token-Ring Physical Subarea Connections	6-28
Defining Token-Ring Logical Subarea Connections	6-29
Differences between Subarea and Peripheral Logical Connections	6-33
3746 Model 900 Service Processor LAN	6-34
Converting Existing Token-Ring Resources to 3746 Model 900 Token-Ring Resources	6-35
Performance Characteristics	6-39
Data Transfer	6-39
Timers for Logical Connections	6-44
Logical Line Error Recovery and Retries	6-47
Logical Line Retries	6-47
Remote Loading and Activation over a Token-Ring Line	6-48
Sample Token-Ring Resource Definitions	6-48
<b>Chapter 7. Integrated Services Digital Network (ISDN) Resources</b>	7-1
Introduction to 3746 Model 900 ISDN	7-1
What Is ISDN?	7-1
NCP ISDN Terms	7-3
Definition Statements for Defining ISDN Resources	7-4
Defining ISDN Physical Lines (D-Channels)	7-5
NDF-Added Keywords for ISDN Physical Lines (D-Channels)	7-10
Sample Definition of an ISDN Physical Line (D-Channel)	7-10
Defining ISDN B-Channels	7-10
NDF-Added Keywords for ISDN B-Channels	7-12
Sample Definition of an ISDN B-Channel	7-12
Defining ISDN Logical Lines	7-13
Defining ISDN Logical Subarea Lines	7-13
NDF-Added Keywords for ISDN Logical Subarea Lines	7-18
Sample Definition of an ISDN Subarea Link	7-18
Defining ISDN Logical Peripheral Lines	7-18
NDF-Added Keywords for ISDN Logical Peripheral Lines	7-21
Sample Definition of a ISDN Peripheral Link	7-21
Unassigned Logical Line Pools	7-22
Defining Device Addresses to VTAM	7-22
Establishing a Connection	7-26
Controlling ISDN B-Channel Connections	7-28
Defining ISDN Subarea Connectivity through a Terminal Adapter or BAN Device	7-31
Remote Loading and Activation over an ISDN Line	7-32
Coding ISDN Definitions for the Best Performance	7-33
Performance-Related Keywords	7-33
ISDN Accounting	7-34
Sample ISDN Definition	7-35

<b>Chapter 8. Type 2.1 Node Support</b> . . . . .	8-1
Defining Type 2.1 Physical Units and Independent Logical Units . . . . .	8-1
Type 2.1 Support Functions . . . . .	8-6
Independent Logical Unit Resource Pools . . . . .	8-10
Independent LUs in a Nonnative Network . . . . .	8-11
NCP and VTAM As a Composite Type 2.1 Node . . . . .	8-13
Generating APPN and LEN Support . . . . .	8-14
Generating APPN HPR Support in NCP . . . . .	8-14
 <b>Chapter 9. Block Handlers</b> . . . . .	 9-1
Defining a Block Handler . . . . .	9-1
Defining a Block Handler Set . . . . .	9-4
Defining Resources to Use a Block Handler Set . . . . .	9-6
 <b>Chapter 10. Dynamic Reconfiguration</b> . . . . .	 10-1
Adding and Deleting Dynamically Reconfigurable Resources . . . . .	10-1
Defining Dynamically Reconfigurable Physical Unit Resources . . . . .	10-2
Defining Dynamically Reconfigurable Logical Unit Resources . . . . .	10-4
Dynamic Reconfiguration for SDLC 3270 Devices . . . . .	10-5
Dynamic Reconfiguration for Frame-Relay Devices . . . . .	10-5
Dynamic Reconfiguration for Frame-Relay Internet Devices . . . . .	10-6
Defining NCP Channel Connections from the Host . . . . .	10-7
 <b>Chapter 11. Routes between Subareas</b> . . . . .	 11-1
Transmission Groups Between Subareas . . . . .	11-1
Explicit Routes . . . . .	11-1
Guidelines for Defining Explicit Routes . . . . .	11-3
Defining Explicit Routes . . . . .	11-4
Virtual Routes . . . . .	11-10
Dynamic Path Update . . . . .	11-13
Defining Routes for Mixed-Level Networks . . . . .	11-14
Using IBM Network Design Products to Define Routes . . . . .	11-15
 <b>Chapter 12. Connections between Subarea Nodes</b> . . . . .	 12-1
Subarea Links and Link Stations . . . . .	12-1
Point-to-Point Subarea Links . . . . .	12-2
Multipoint Subarea Links . . . . .	12-2
Defining SDLC Subarea Links . . . . .	12-3
Defining Configurable Point-to-Point Subarea Links . . . . .	12-8
Defining Nonconfigurable Point-to-Point Subarea Links . . . . .	12-10
Defining Multipoint Subarea Links . . . . .	12-11
Defining Switched Subarea Links . . . . .	12-13
Token-Ring Subarea Links . . . . .	12-15
Frame-Relay Subarea Links . . . . .	12-15
ISDN Subarea Links . . . . .	12-15
Transmission Groups . . . . .	12-15
Single-Link Transmission Groups . . . . .	12-16
Multilink Transmission Groups . . . . .	12-16
MLTG Segment Size . . . . .	12-23
Parallel Transmission Groups . . . . .	12-26
Power-Off Feature in a Link-Attached Controller . . . . .	12-28
Remote Loading and Activation of a Link-Attached NCP . . . . .	12-29
Defining Casual Connection Links between Subareas . . . . .	12-29

<b>Chapter 13. Customized Functions</b> . . . . .	13-1
User Line Control . . . . .	13-1
Programmed Resources . . . . .	13-3
Network Addressable Units . . . . .	13-4
User Channel Control Code . . . . .	13-4
Entry Points and Library Member Names . . . . .	13-5
Library Members That Contain Linkage Editor Statements . . . . .	13-6
NDF Standard Attachment Facility . . . . .	13-8
<b>Chapter 14. Interconnected Networks</b> . . . . .	14-1
Defining a Gateway NCP . . . . .	14-2
Defining Nonnative Networks . . . . .	14-4
Defining Connections to Adjacent Networks . . . . .	14-5
Defining Cross-Network Sessions . . . . .	14-8
Address Control Blocks . . . . .	14-8
Half-Session Control Blocks . . . . .	14-10
Placement of GWNAU Definition Statements . . . . .	14-12
Defining Cross-Network Paths . . . . .	14-15
Defining Dynamic Network Allocation . . . . .	14-18
Defining Cross-Network Paths to VTAM . . . . .	14-23
Defining Cross-Network Session Pacing . . . . .	14-24
Defining Gateway Session Accounting and Accounting Exit Routines . . . . .	14-24
<b>Chapter 15. Internet Resources</b> . . . . .	15-1
Definition Statements for NCP Internet Resources . . . . .	15-3
Specifying Internet Addresses . . . . .	15-4
Defining the Owning TCP/IP Host . . . . .	15-7
Defining NCST Session Interfaces . . . . .	15-8
Defining 370 I/O Channels for IP . . . . .	15-18
Defining ESCON Channels for IP . . . . .	15-22
Defining Ethernet-Type LAN Attachments . . . . .	15-25
Defining NTRI Attachments for IP . . . . .	15-31
Defining an Internal NCP to Model 900 Point-to-Point IP Connection . . . . .	15-39
Defining Frame-Relay Attachments for IP . . . . .	15-44
Defining Internet Routes . . . . .	15-52
Routes Defined by NCPROUTE through RIP . . . . .	15-53
Routes Implicitly Defined by NCP Internet Interfaces . . . . .	15-53
Defining Routes Explicitly . . . . .	15-54
Dynamic Reconfiguration of Frame Relay Internet Hosts . . . . .	15-57
Migrating Internet Resources to NCP V7R1 and Later Releases . . . . .	15-57
Coding Internet Route Definitions for Best Performance . . . . .	15-59
Sample Internet Resource Configuration and Definitions . . . . .	15-60
<b>Chapter 16. Frame-Relay Resources</b> . . . . .	16-1
Introduction to Frame Relay . . . . .	16-1
What Is Frame Relay? . . . . .	16-1
NCP Frame-Relay Terms . . . . .	16-5
Definition Statements for Defining NCP Frame-Relay Resources . . . . .	16-7
Defining Frame-Relay Physical Lines . . . . .	16-8
Defining Nonswitched Frame-Relay Physical Lines . . . . .	16-8
Defining Switched Frame-Relay Physical Lines . . . . .	16-18
NDF-Added Keywords for Frame-Relay Physical Lines . . . . .	16-20
Sample Definition of a Frame-Relay Physical Line . . . . .	16-21
Defining Automatic Frame-Relay Backup over an ISDN . . . . .	16-22

Defining Frame-Relay Logical Subarea Lines . . . . .	16-27
Determining a T1 (Reply) Timer Value for a Local Link . . . . .	16-36
NDF-Added Keywords for Frame-Relay Logical Subarea Lines . . . . .	16-37
Converting SDLC Subarea Links to Frame Relay . . . . .	16-38
Sample Definition of a Frame-Relay Subarea Link . . . . .	16-42
Sample Definition of a Frame-Relay BAN Subarea Link . . . . .	16-43
Defining Frame-Relay Logical Peripheral Lines . . . . .	16-45
Unassigned Logical Line Pools . . . . .	16-50
Defining Peripheral Device Addresses to VTAM . . . . .	16-51
NDF-Added Keywords for Frame-Relay Logical Peripheral Lines . . . . .	16-53
Sample Definitions of Frame-Relay Peripheral Links . . . . .	16-54
Defining Frame Handler Connections . . . . .	16-57
Dynamic Reconfiguration . . . . .	16-61
Sample Definition of Frame Handler Connections . . . . .	16-62
Defining NTRI Attachments for a Frame-Relay Network . . . . .	16-63
Defining NTRI Physical Links . . . . .	16-63
Defining NTRI Frame Handler Logical Links . . . . .	16-66
NDF-Added Keywords for NTRI Frame Handler Logical Lines . . . . .	16-70
3746 Model 900 Frame Relay . . . . .	16-72
Remote Loading and Activation over a Frame-Relay Line . . . . .	16-73
Coding Frame-Relay Definitions for the Best Performance . . . . .	16-74
Performance-Related Keywords . . . . .	16-74
Sample Frame-Relay Configurations and Definitions . . . . .	16-77
Frame-Relay Network with Subarea Link Support . . . . .	16-77
Frame-Relay Network with Frame-Relay Switching Support . . . . .	16-78
Frame-Relay Network with FHSPs and TESP s . . . . .	16-81
Frame-Relay Network with 3746 Model 900 . . . . .	16-85
Frame-Relay Network with Internal PVC Segment between 3746 Model 900 and NCP on a 3745 . . . . .	16-89
Switched Frame-Relay Physical Line . . . . .	16-93





---

## Chapter 4. Channel Links and Access Methods

A *System/370 I/O channel link* is a connection between an IBM 370 I/O channel and an IBM 3745 Communication Controller. An *Enterprise Systems Connection (ESCON) channel link* is a connection between an ESCON channel and a 3746 Model 900 installed in the controller. The 3746 Model 900 improves NCP performance by performing NCP data link control processing. To use the 3746 Model 900, you need to obtain a license for the NCP 3746 Model 900 Feature from IBM.

A 370 I/O channel link or an ESCON channel link can be a subarea link that connects NCP to a subarea host node (a type 5 physical unit) or a peripheral link that connects NCP to a peripheral host node (a type 2.1 physical unit), or to an internet host node (a type 1 physical unit). See “Defining ESCON Links” on page 4-9 for more information about ESCON links. See “Defining 370 I/O Channels for IP” on page 15-18 for more information about peripheral internet hosts.

Figure 4-1 shows an illustration of 370 I/O channel links.

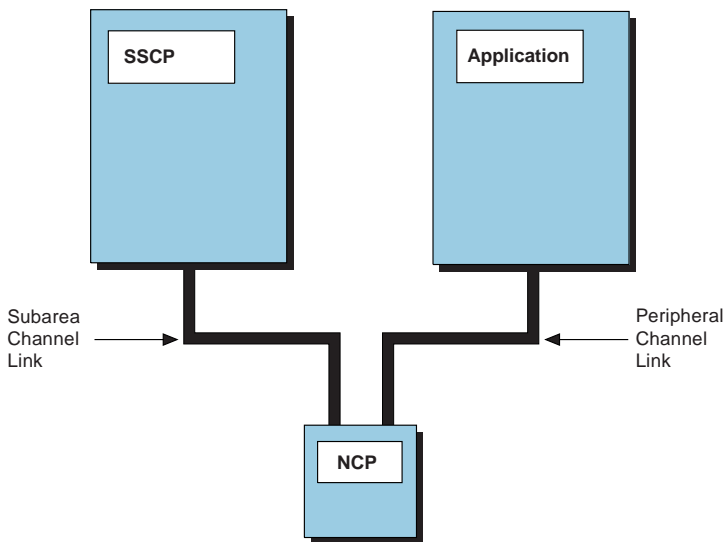

Figure 4-1. 370 I/O Channel Attachments

The following sections provide information about how to define 370 I/O channel attachments and ESCON links.

---

### Defining System/370 I/O Channel Links

This section describes the function of subarea channel links and peripheral channel links, and the definition statements and keywords that define those links. It contains sample figures to illustrate the link connections and coding samples to show you how to code both types of links in your system generation definition.

Channel link definitions appear in a certain order in the generation definition. For more information on the generation definition order for the GROUP definition statement, see “Definition Statement Usage and Sequence for NCP Generation” on page 1-8.

### Subarea Channel Links

A subarea node exists within a network as an addressable area connected to the host by a channel link. Code the following definition statements and keywords to provide NCP with information about how it is to manage the channel link, the assigned address of the channel adapter, and the type of physical unit attached to the link.

GROUP	LNCTL
LINE	ADDRESS CA CASDL DELAY DYNADMP HICHAN INBFERS LOCHAN MONLINK NCPA TIMEOUT TRANSFR
PU	MAXBFRU PUTYPE

#### GROUP

LNCTL on the GROUP definition statement identifies the type of line control used for all lines defined in the group. Code LNCTL=CA to define a subarea channel link.

#### LINE

ADDRESS on the LINE definition statement specifies the address of the channel adapter in the communication controller.

CA specifies the operating mode for the channel adapter:

- Code CA=TYPE6 (or CA=TYPE6-TPS for a channel adapter with a two-processor switch) to use either a type 6 or type 7 channel adapter in non-buffer-chaining mode.
- Code CA=TYPE7 (or CA=TYPE7-TPS) to use a type 7 channel adapter in buffer-chaining mode. INBFERS on the LINE definition statement is ignored for buffer-chaining mode.
- The default is CA=TYPE6 for a channel adapter associated with a line operating in emulation mode. Otherwise, the default is CA=TYPE7.

The type 7 channel adapter does not support emulation subchannels, even when you define it as a type 6. Consequently, when you use a type 7 channel adapter, do not code DYNADMP, HICHAN, or LOCHAN on the LINE definition statement. Because the default is CA=TYPE7 for a channel adapter not associated with an emulation-mode line, you need to code CA=TYPE6 or CA=TYPE6-TPS to use the dynamic dump facility with a channel not associated with an emulation-mode line.

CASDL (CA slowdown limit) defines the maximum amount of time the subarea channel link can block inbound data before signaling that the station is inoperative.

DELAY defines the maximum amount of time NCP is to wait between the time data is available to the host and the time the attention signal is sent over the subarea channel link to a subarea host node.

DYNADMP specifies whether you want to include the dynamic dump facility in NCP. If you include this facility, DYNADMP also specifies the address of the emulation subchannel in the channel adapter over which dynamic dump data can be sent to the host processor.

HICHAN defines either the highest subchannel address associated with any line operating in emulation mode or the address of the subchannel used for dynamic dump data transfer.

INBFRS specifies the number of controller buffers initially allocated for the first data transfer received from the host processor. The number of controller buffers subsequently allocated dynamically depends on the amount of data received.

LOCHAN defines the lowest subchannel address on the channel adapter associated with any line operating in emulation mode.

MONLINK specifies whether SMMF is to activate and monitor subarea links. You can code MONLINK=YES, NO, or CONTINUOUS. Code MONLINK=YES on at least one subarea line, channel link, channel link station, or ESCON logical line definition in order to allow NCP activation after a load.

NPCCA specifies whether the channel adapter is to be used in network control mode. When a channel adapter is disabled, it is available only for emulation subchannel use. Any type 6 channel adapter not connected to an operational host processor must be disabled.

TIMEOUT specifies the amount of time NCP is to wait for a response to an attention signal it sent to the host. When the timeout value expires, NCP initiates channel discontact.

TRANSFR defines the maximum number of buffers that are available to NCP for a single data transfer operation from a subarea channel link. If the value coded on TRANSFR is greater than the largest PIU to be received by NCP, buffer storage and NCP cycles are wasted.

**Note:** If you use the VTAM MODIFY LOAD command to add or replace a load module on the controller hard disk, the value of TRANSFR times the NCP buffer size (BFRS on the BUILD definition statement) must be at least 2048.

### PU

MAXBFRU on the PU definition statement defines the maximum number of buffer units the access method allocates to receive data from NCP.

PUTYPE identifies the type of physical unit to be associated with the channel link. Code PUTYPE=5 to define a subarea channel link.

**Note:** A channel adapter for a PEP generation can operate as a subarea or a peripheral channel link, or in emulation mode. Therefore, when the channel adapter operates as a subarea or a peripheral channel link, PEP can share the channel adapter definition already coded for NCP. When the channel adapter oper-

## Defining System/370 Channel Links

ates only in emulation mode, code HICHAN and LOCHAN on the LINE definition statement and do not code a PU definition statement.

Channel link definitions appear in a certain order in the generation definition. For more information on the order for the GROUP definition statement, see "Definition Statement Usage and Sequence for NCP Generation" on page 1-8.

### Sample Subarea Channel Link Definition

Figure 4-2 shows how to define the subarea channel link shown in Figure 4-1 on page 4-1. PUTYPE=5 identifies a link to a subarea host.

GA03CA	GROUP	LNCTL=CA, DELAY=0.2, TIMEOUT=20, NCPCA=ACTIVE, TRANSFR=33, CASDL=20	Define channel adapter line group Delay .2 seconds before sending resp Wait 20 seconds for response to attn Channel adapter is active 33 buffers available for transfer Block data 20 seconds when inop
*			
LA03CA00	LINE	ADDRESS=P5, CA=TYPE7-TPS, DELAY=0.3	Physical position 5 Type 7 adapter with two processor switch Delay .3 seconds before sending resp
*			
PA03CA00	PU	PUTYPE=5	Subarea host node

Figure 4-2. Example: Defining Subarea Channel Links

## Peripheral Channel Links

A peripheral node exists outside of a subarea network and supports its own local addresses. Because the peripheral node might require boundary assistance from an adjacent subarea node, it is connected to the adjacent subarea host by a peripheral channel link. The peripheral channel link connecting a type 2.1 physical unit peripheral host node to an adjacent subarea node is a 370 I/O channel attachment. A peripheral channel link appears to an SSCP as a type 2.1 physical unit attached to a System/370 channel. NCP supports type 2.1 physical units that reside in a System/370, 30xx, or 4300 processor and attach to NCP through a peripheral channel link.

Both peripheral and subarea channel links are defined with GROUP, LINE, and PU definition statements. However, when you define peripheral channel links, one or more LU definition statements must follow the PU definition statement (except for APPN connections).

Code the following definition statements and keywords to provide NCP with information about how it is to manage the channel link, the assigned address of the link, and the type of attached physical unit.

GROUP	LNCTL
LINE	ADDRESS CA CASDL DELAY DYNADMP HICHAN INBFRS LOCHAN NCP TIMEOUT TRANSFR
PU	ANS MAXBFRU PUTYPE
LU	LOCADDR

LNCTL on the GROUP definition statement identifies the type of line control used for all lines defined in the group. Code LNCTL=CA to define a peripheral channel link.

ADDRESS on the LINE definition statement specifies the logical or physical address of the channel adapter in the communication controller.

CA specifies the type of channel adapter attached to the communication controller. You can define either a type 6 or a type 7 channel adapter. The following rules apply to the definition of channel adapters:

- Code CA=TYPE7 to define a type 7 channel adapter in buffer-chaining mode.
- Code CA=TYPE7-TPS to define a type 7 channel adapter in buffer-chaining mode with a two-processor switch.
- Code CA=TYPE6 to define a type 6 channel adapter.
- Code CA=TYPE6-TPS to define a type 6 channel adapter with a two-processor switch.

You can use a type 7 channel adapter in compatibility mode by defining it to NCP as a type 6 channel adapter. Compatibility mode causes a type 7 channel adapter to interface with NCP as a type 6 channel adapter without emulation subchannel (ESC) support because type 7 channel adapters do not support ESC. If you code CA=TYPE7 or CA=TYPE7-TPS for both type 6 and type 7 channel adapters, NCP automatically selects the correct operation mode for each type of adapter.

When you use a type 7 channel adapter, do not code the DYNADMP, HICHAN, or LOCHAN keyword on the LINE definition statement. When you code CA=TYPE7 or CA=TYPE7-TPS, NCP ignores the INBFRS keyword on the LINE definition statement.

CASDL (CA slowdown limit) defines the maximum amount of time the peripheral channel link can block inbound data before signaling that the station is inoperative.

## Defining System/370 Channel Links

DELAY defines the maximum amount of time NCP is to wait between the time data is available for the host and the time the attention signal is sent over the peripheral channel link to a peripheral host node.

DYNADMP specifies whether you want to include the dynamic dump facility in NCP. If you include this facility, DYNADMP also specifies the address of the emulation subchannel in the channel adapter over which dynamic dump data can be sent to the host processor.

HICHAN defines either the highest subchannel address on the channel adapter associated with any line operating in emulation mode or the address of the subchannel used for dynamic dump data transfer.

INBFRS specifies the default number of controller buffers initially allocated for the first data transfer received from the host processor. The number of controller buffers subsequently allocated dynamically depends on the amount of data received.

LOCHAN defines the lowest subchannel address on the channel adapter associated with any line operating in emulation mode.

NCPA determines whether the channel is to be enabled for use in network control mode. When a channel adapter is disabled, it is available only for emulation subchannel use. Any type 6 channel adapter not connected to an operational host processor must be disabled.

TIMEOUT specifies the amount of time NCP waits for a response to an attention signal it sent to the host. When the timeout interval expires, NCP initiates channel discontact.

TRANSFR defines the maximum number of buffers that are available to NCP for a single data transfer operation from a channel link. If the value coded on TRANSFR is greater than the largest PIU to be received by NCP, buffer storage and NCP cycles are wasted.

ANS on the PU definition statement specifies whether the link station is to continue operation when NCP enters automatic network shutdown (ANS). ANS=CONTINUE causes NCP to continue to service the link station when automatic network shutdown is initiated.

MAXBFRU defines the maximum number of buffer units the access method allocates to receive data from NCP.

PUTYPE defines the type of physical unit associated with the channel link. PUTYPE=2 defines a peripheral channel link.

LOCADDR on the LU definition statement specifies the decimal address of the logical unit.

### Sample Peripheral Channel Link Definition

Figure 4-3 shows how to define the peripheral channel link shown in Figure 4-1 on page 4-1. PUTYPE=2 and the LU definition statement identify a link to a peripheral host.

GA03CA	GROUP	LNCTL=CA, DELAY=0.2, TIMEOUT=20, NPCCA=ACTIVE, TRANSFR=33, CASDL=20	Define channel adapter line group Delay .2 seconds before sending resp Wait 20 seconds for response to attn Channel adapter is active 33 buffers available for transfer Block data 20 seconds when inop
*			
LA03CA01	LINE	ADDRESS=1, CA=TYPE7, TIMEOUT=10	Channel adapter address is 1 Type 7 channel adapter Wait 10 seconds for response to attn
*			
PA03CA01	PU	PUTYPE=2, MAXBFRU=8	Peripheral host node Access method allocates 8 buffers
*			
CA01LU1	LU	LOCADDR=1	

Figure 4-3. Example: Defining Peripheral Channel Links

## Migrating to a Type 7 Channel Adapter

A type 7 channel adapter supports buffer chaining; a type 6 channel adapter operates only in compatibility (non-buffer-chaining) mode. Buffer chaining improves channel adapter performance by reducing the number of NCP interrupts during data transfer. Buffer chaining also improves channel efficiency by reducing the time the channel is held while no data is being transferred. See *NCP and EP Reference* for more information on buffer-chaining data transfer.

You can use a type 7 channel adapter in compatibility mode by defining it as type 6 channel adapter in your generation definition. This also lets you migrate from a type 6 channel adapter to a type 7 channel adapter in two steps:

1. Install the type 7 channel adapter and use it in compatibility mode.
2. Regenerate NCP to define the type 7 channel adapter.

#### Notes:

1. Update your NCP before migrating to buffer chaining on your communication controller.
2. The type 7 channel adapter does not support emulation subchannels. If you use a type 7 channel adapter as a type 6 channel adapter with emulation subchannels, NCP initialization of the channel adapter will fail.

## Loading and Dumping a Channel-Attached NCP

Subarea channel links and EP channel adapters support the loading and dumping of NCP. You do not need to code the IPL keyword on the LINE definition statement for these resources because NCP loads and dumps automatically.

## Sample System/370 Channel Link Configuration and Definition

The following example of a generation definition shows how to define both subarea and peripheral channel link connections using a type 7 channel adapter. See “Subarea Channel Links” on page 4-2 and “Peripheral Channel Links” on page 4-4 for more information about each individual type of connection.

### Sample Channel Link Definition Using Type 7 Channel Adapters

Figure 4-4 shows two type 7 channel adapters attached to subarea and peripheral host processors.

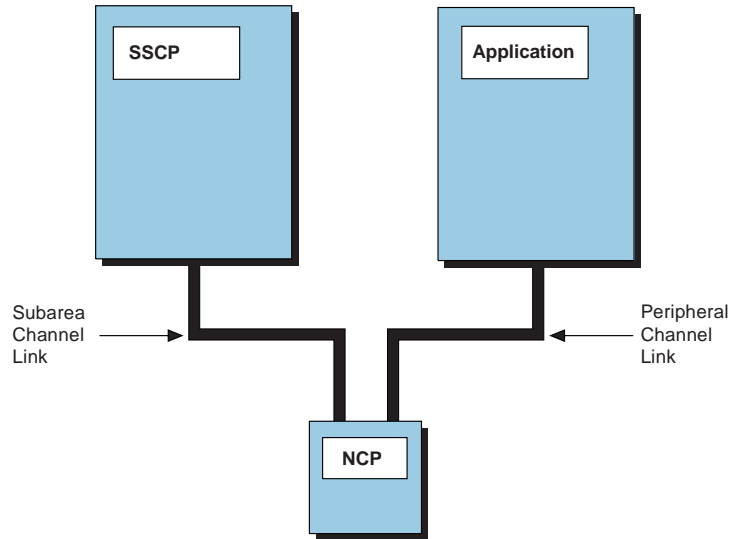

Figure 4-4. Subarea and Peripheral Channel Adapter Connections

Figure 4-5 shows how to define the type 7 channel adapters illustrated in Figure 4-4.

GA03CA	GROUP	LNCTL=CA, DELAY=0.2, TIMEOUT=20, NCPCA=ACTIVE, TRANSFR=33, CASDL=20	Define channel adapter line group Delay .2 seconds before sending resp Wait 20 seconds for response to attn Channel adapter is active 33 buffers available for transfer Block data 20 seconds when inop
*			
LA03CA00	LINE	ADDRESS=P5, CA=TYPE7-TPS, DELAY=0.3	Physical position 5 (logical address 0) Type 7 adapter with two processor switch Delay .3 seconds before sending resp
*			
PA03CA00	PU	PUTYPE=5	Subarea host node
*			
LA03CA01	LINE	ADDRESS=1, CA=TYPE7, TIMEOUT=10	Channel address 1 (physical position P6) Type 7 channel adapter Wait 10 seconds for response to attn
*			
PA03CA01	PU	PUTYPE=2, MAXBFRRU=8	Peripheral host node Access method allocates 8 buffers
*			
CA01LU1	LU	LOCADDR=1	

Figure 4-5. Example: Defining a Type 7 Channel Adapter



## Defining ESCON Links

Using the 3746 Model 900, Enterprise Systems Connection (ESCON) links provide logical connections to subarea and peripheral hosts in your network.<sup>1</sup> ESCON links can be established directly to a host processor or through an ESCON Director (ESCD), which permits dynamic ESCON link switching.

An ESCON adapter provides a point-to-point physical connection, called an ESCON link, to an adjacent ESCON link device.<sup>2</sup> Each ESCON link can support multiple logical lines between NCP and other ESCON devices. Each logical line can support multiple programs such as VTAM or transaction processing facility (TPF) as logical devices in much the same way as a multipoint SDLC connection can be used to communicate with multiple physical devices.

Figure 4-6 shows the System/370 multidrop topology used to connect NCP1 and NCP2 to Host1 using a type 6 or type 7 channel adapter. Figure 4-7 on page 4-10 shows the physical ESCON star topology used to connect NCP1 and NCP2 to Host1 and Host2. When the adjacent ESCON link device is an ESCD, the ESCON link becomes an attachment to a star configuration with the ESCD functioning as the hub of the configuration.

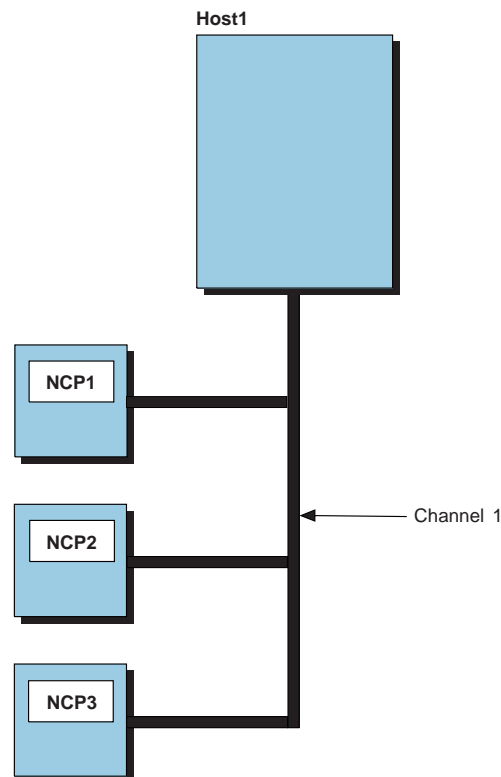

Figure 4-6. System/370 Multidrop Topology

<sup>1</sup> The 3746 Model 900 is required to define ESCON links. See "NCP V7R2, NCP V7R3, NCP V7R4, NCP V7R5, NCP V7R6, NCP V7R7, NCP V7R8" on page xxx for a description of the Feature which supports the 3746 Model 900.

<sup>2</sup> ESCON channel adapters do not support IBM special products or user-written code, or channel intensive mode error reporting.

## Defining ESCON Links

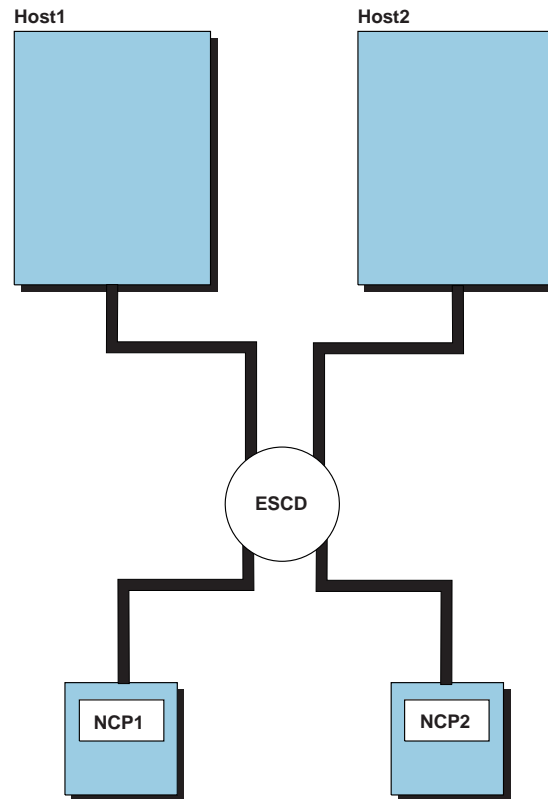

Figure 4-7. ESCON Star Topology

Figure 4-8 on page 4-11 shows how logical lines can be established between NCP and any host physically attached to the ESCD. A physical line attached to an ESCON adapter can support one or more logical lines with separate physical units defined to the same or different hosts. For example, in Figure 4-8 on page 4-11, physical unit 1 on logical line 1 in NCP1 is defined to Host1 while physical unit 2 on logical line 2 in NCP1 is defined to Host2.

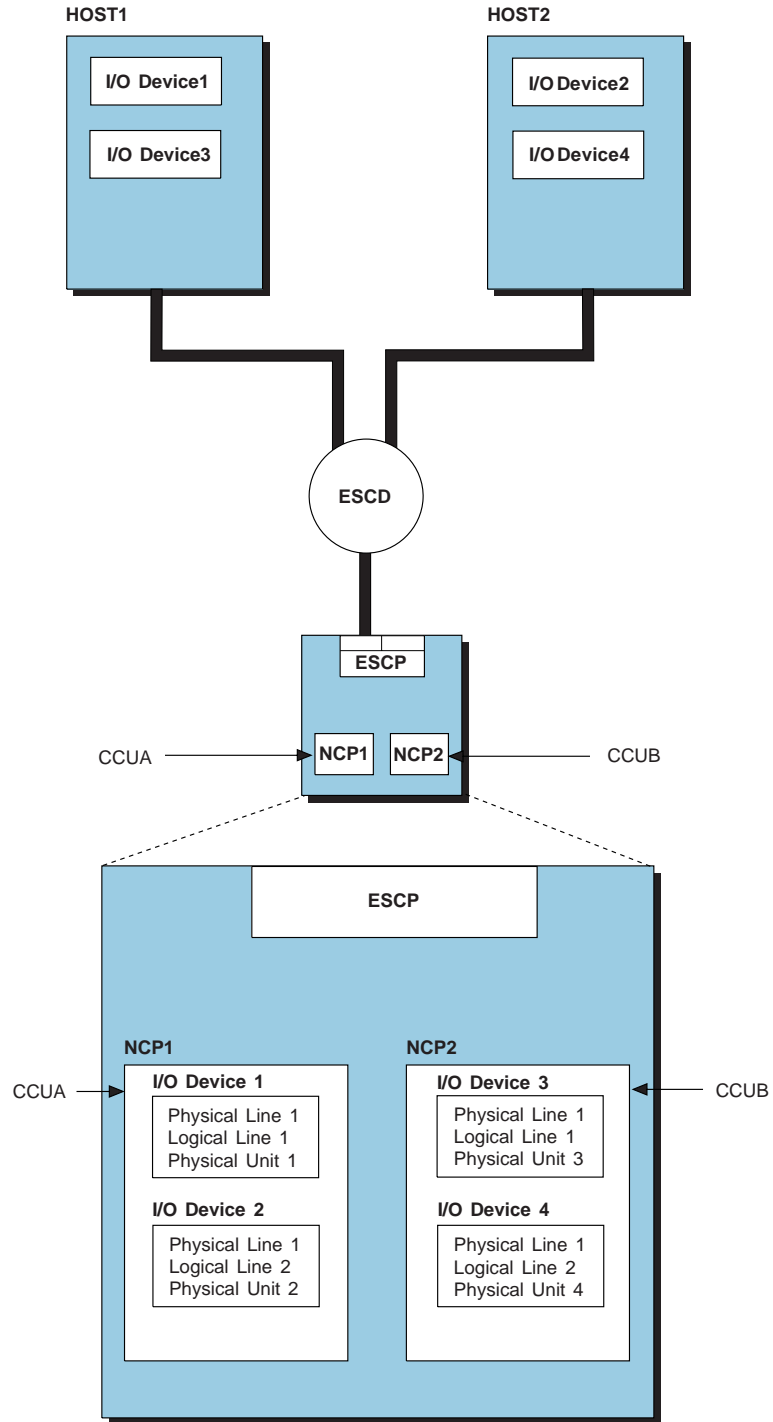

Figure 4-8. ESCON Channel Configuration with Two Hosts and Two NCPs

You can define up to 32 connections, to the same or different hosts. The configuration of the logical lines to those hosts is defined dynamically using the MOSS extended (MOSS-E) user interface. See “Using MOSS Extended to Configure ESCON Links” on page 4-22 for more information about the MOSS-E user interface. See “3746 Model 900 Connectivity Subsystem” on page 3-6 for an introduction to the 3746 Model 900.

## Defining ESCON Links

Figure 4-9 on page 4-12 shows a single NCP with one ESCON adapter linking to one or more host processors. Notice that there is no direct correlation between the channel adapter on the communication controller and the host processor destination. Define the ESCON adapter as a physical line on a separate GROUP definition and define the paths to the host processors as *host links*, or logical lines.

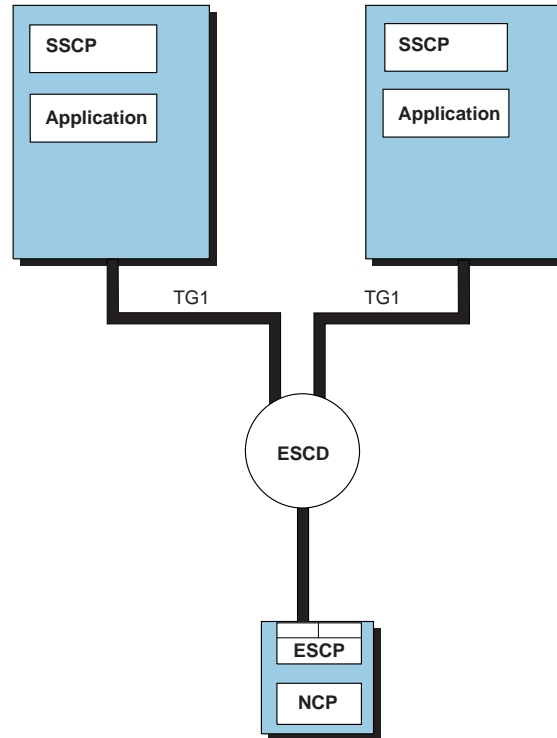

Figure 4-9. ESCON Channel Configuration with Two Hosts and One NCP

## ESCON Generation Assistant

When you define ESCON channel adapters, the parameters that define the channels must be carefully coordinated among NDF, the I/O Configuration Program (IOCP), and MOSS-E. Once you have your ESCON configuration planned, you can simplify the task of defining ESCON channels by using the 3745 ESCON Generation Assistant, which produces cross-checked output for NDF, IOCP, and MOSS-E, including automatic calculation of host link addresses. The output produced by running the 3745 ESCON Generation Assistant becomes the input entered for NDF, IOCP, and MOSS-E.

The 3745 ESCON Generation Assistant runs on an IBM PS/2 under IBM OS/2. It is packaged on a diskette in *3745 Models 21A through 61A Migration and Planning Guide*.

## ESCON Physical Lines

An ESCON physical line definition identifies the ESCON processor to NCP. Each ESCON processor is connected to a single ESCON channel. The physical connection can be to an adjacent node or to an ESCD connected to one or more nodes as shown in Figure 4-9 on page 4-12.

Code the following definition statements and keywords to provide NCP with information about the physical ESCON connection and how to collect performance data and recover from errors.

GROUP	LNCTL
LINE	ADDRESS SPEED
PU	ANS NPACOLL PUTYPE SRT XMONLNK

### GROUP

LNCTL on the GROUP definition statement identifies the type of line control used for all lines defined in the group. Code LNCTL=CA to define an ESCON link. Create a new GROUP definition statement when you define an ESCON link to separate ESCON link definitions from other channel definitions in the system generation definition.

### LINE

ADDRESS on the LINE definition statement specifies the physical address of the ESCON adapter in the communication controller. You can define only one ESCON physical line for any adapter position. The address you choose for this physical line must be valid for ESCON connections. Refer to *NCP, SSP, and EP Resource Definition Reference* for the range of valid ESCON line numbers.

SPEED specifies an estimated data transmission rate to be used by the NetView Performance Monitor (NPM) to compute line utilization statistics.

### PU

ANS on the PU definition statement specifies whether the ESCON link is to continue operation when NCP enters automatic network shutdown (ANS). ANS=CONTINUE causes NCP to continue to service the ESCON physical line when automatic network shutdown is initiated.

NPACOLL specifies whether NPM is to collect performance statistics about the ESCON physical line.

PUTYPE defines the type of physical unit associated with the ESCON physical line. Code PUTYPE=1 to identify an ESCON adapter.

SRT specifies a maximum value for the total number of transmissions and for the total number of error retries.

## Defining ESCON Links

XMONLNK specifies whether SMMF is to initially activate and monitor the physical unit. Activation for an ESCON link is different than activation of a type 6 or type 7 channel adapter. Code XMONLNK=YES when you define any ESCON physical line that is used to load and activate NCP. Code MONLINK=YES on the corresponding definition of any ESCON logical line that is used to load and activate NCP. If you code XMONLNK=NO or MONLINK=NO, the NCP load and activation over this physical line will fail.

See *NCP and EP Reference* for more information about SMMF.

### Sample Definition of an ESCON Physical Line

Figure 4-10 shows how to define an ESCON physical line. ESCON adapter address 2240 is used in this example.

```
G31RSOC1 GROUP LNCTL=CA,          Define channel adapter line group *
                SPEED=144000000,    *
                SRT=(32768,32768),  *
                XMONLNK=YES
*
A31S2240 LINE  ADDRESS=2240        ESCON physical line 2240
*
A31P2240 PU    ANS=CONTINUE,       *
                PUTYPE=1
```

Figure 4-10. Example: Defining an ESCON Physical Line

## ESCON Logical Lines

The ESCON logical line (host link) definition establishes the logical connection from NCP to the host processor. You can define logical lines to both subarea and peripheral nodes (type 5 and type 2.1 physical units). You can also define logical lines to internet host nodes (type 1 physical unit). See "Defining 370 I/O Channels for IP" on page 15-18 for more information. ESCON logical lines are associated with ESCON physical channel lines. Use MOSS-E to define a port address for each destination physical unit connected to each logical line. An ESCON logical line supports multiple physical units.

Code the following definition statements and keywords to provide NCP with information about the ESCON logical connection, and how to improve performance, collect performance data, and recover from errors. Code these definition statements and keywords on a separate GROUP definition statement.

GROUP	LNCTL PHYSRSC
LINE	ADDRESS HOSTLINK MAXPU MONLINK SPEED
PU	ADDR ANS CASDL DELAY MAXBFRU MONLINK NETID NPACOLL PUDR PUTYPE SRT TGN TIMEOUT TRANSFR
LU	LOCADDR

## GROUP

LNCTL on the GROUP definition statement identifies the type of line control used for all lines in the group. Code LNCTL=CA to define an ESCON logical line.

PHYSRSC associates the logical line definitions with the corresponding ESCON physical line definition. Make sure the keyword value for PHYSRSC matches the label coded on the PU definition statement that defines the ESCON physical line.

## LINE

ADDRESS on the LINE definition statement specifies the relative line number of the physical line. Do not assign an address to an ESCON logical line. Omit the ADDRESS keyword or code ADDRESS=NONE.

HOSTLINK assigns a logical line number to an ESCON logical line. Assign logical line numbers in sequential order from 1 to 32. The number you assign associates the logical line with attributes defined using MOSS-E. See "Using MOSS Extended to Configure ESCON Links" on page 4-22 for more information.

MAXPU defines the maximum number of physical devices you can attach to the ESCON logical line. Make sure the value of MAXPU represents the number of physical devices attached to the link plus the number of devices you expect to add using dynamic reconfiguration.

MONLINK on the LINE definition statement specifies whether SMMF is to initially activate and monitor an ESCON subarea link. You can code MONLINK=YES, NO, or CONTINUOUS. When you code MONLINK=YES, NCP allows a maximum of eight NCP owners; when you code MONLINK=CONTINUOUS, NCP allows only

## Defining ESCON Links

seven other NCP owners. Code MONLINK=YES on the definition of any ESCON logical line that is used to load and activate NCP. Code XMONLNK=YES on the definition of any physical link station used to load and activate NCP. If you code MONLINK=NO or XMONLNK=NO, the NCP load and activation will fail.

SPEED sets an estimated data transmission rate to be used by NPM to compute line utilization statistics.

### PU

ADDR on the PU definition statement identifies the ESCON device address to the host node on the logical line. The number you code must correspond to the UNITADD value specified in the host IODEVICE definition statement and to the physical unit address defined to MOSS-E. All the ADDR values for a logical line must be unique. Valid ADDR values range from X'01' to X'20'. See "Using MOSS Extended to Configure ESCON Links" on page 4-22 for more information.

ANS specifies whether the ESCON link is to continue operation when NCP enters automatic network shutdown (ANS). Code ANS=CONTINUE to cause NCP to continue to service the ESCON link when automatic network shutdown is initiated.

CASDL defines the maximum amount of time the ESCON station can block inbound traffic due to slowdown before signaling that the station is inoperative.

DELAY specifies the maximum amount of time NCP is to wait between the time data is available to the host and the time the attention signal is presented by an ESCON station to a host node.

MAXBFRU identifies the maximum number of buffer units the access method allocates to receive data from NCP.

MONLINK on the PU definition statement specifies whether SMMF is to initially activate and monitor a link station associated with an ESCON channel link. Code MONLINK=NO if you do not want SMMF to activate and monitor the logical link station even though the logical link is defined with MONLINK=YES or MONLINK=CONTINUOUS. Code MONLINK=YES on the logical PU definition statement that defines an SSCP used to load and activate NCP and code XMONLNK=YES on the corresponding physical PU definition statement.

**Note:** Refer to *Planning for NetView, NCP, and VTAM* more information about the relationship between NCP and VTAM.

NETID names the network containing the adjacent logical link station. The network you name should be defined on the BUILD definition statement in the native network definition or on the NETID definition statement in the non-native network definition.

NPACOLL specifies whether NPM is to collect performance statistics for the ESCON link.

PUDR provides for later deletion of a device from the ESCON logical line connecting it to NCP. Specify PUDR only for peripheral nodes attached to the ESCON logical line.



PUTYPE defines the type of physical unit associated with the channel link. Code PUTYPE=5 for links to subarea nodes, and PUTYPE=2 for links to type 2.1 peripheral nodes.

SRT specifies a maximum value for the total number of transmissions and for the total number of error retries.

TGN defines the number of the transmission group to which the subarea link or peripheral link belongs. For a subarea link (PUTYPE=5) the TGN value is used in the PATH definition statement for routing data along the subarea link. You can omit TGN when defining a link to a peripheral node (PUTYPE=2). (You can code the TGN keyword for a link to an APPN peripheral node; however, TGN becomes a VTAM-only keyword.)

TIMEOUT specifies the amount of time NCP is to wait for a response to an attention signal sent to the host before NCP initiates channel discontact.

TRANSFR defines the maximum number of buffers that are available to NCP for a single data transfer operation from a channel link. If the value coded on TRANSFR is greater than the largest PIU to be received by NCP, buffer storage and NCP cycles are wasted.

**Note:** If you use the VTAM MODIFY LOAD command to add or replace a load module on the controller hard disk, the value of TRANSFR times the NCP buffer size (BFRS on the BUILD definition statement) must be at least 2048.

## LU

LOCADDR on the LU definition statement specifies the decimal address of the logical unit associated with the peripheral device.

### Sample Definition of an ESCON Logical Line

Figure 4-11 shows an example of an ESCON link.

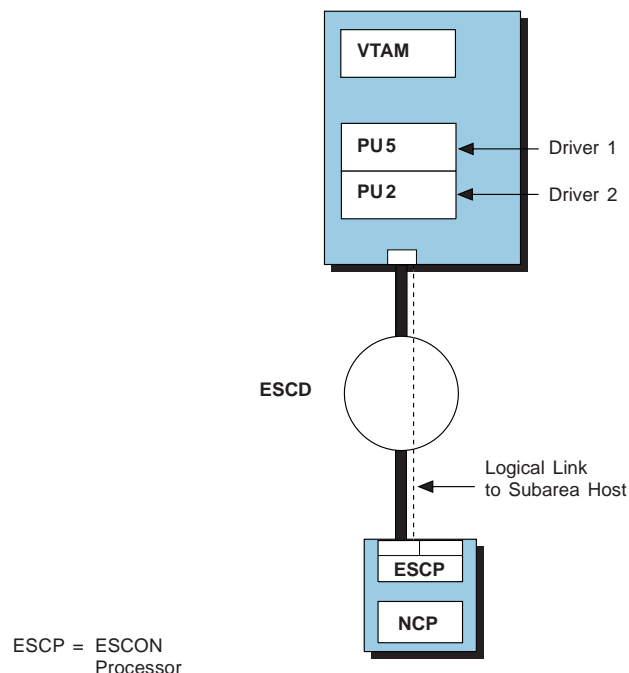

Figure 4-11. ESCON Logical Line that Supports an NCP-VTAM Subarea Link

## Defining ESCON Links

Figure 4-12 shows how to code the ESCON logical line shown in Figure 4-11 on page 4-17. HOSTLINK=1 indicates that this is the first logical line defined to MOSS-E for this physical line. Figure 4-16 on page 4-24 shows the relationship between the Input/Output configuration data set (IOCDS), the NCP generation definition, and MOSS-E. In the IOCDS, UNITADD=01 corresponds to ADDR=01 on the PU definition statement.

```
*****
*      ESCON LOGICAL LINE GROUP      *
*****
*
G31LSOC1 GROUP CASDL=0.0,          ESCON logical line group  *
                DELAY=0.2,          *
                LNCTL=CA,            *
                MAXPU=16,            *
                PHYSRSC=A31P2240,    Associate logical with physical *
                PUDR=YES,            *
                SPEED=144000000,     *
                SRT=(20000,20000),   *
                TIMEOUT=840.0,      *
                TRANSFR=200          *
*
*****
*      ESCON LOGICAL LINE 1 GROUP 1 (ESCON PHYSICAL ADAPTER 2240)  *
*****
*
A31S1L1 LINE ADDRESS=NONE,          *
                HOSTLINK=1,          Host link 1 (X'C5')      *
                MONLINK=NO          *
*
A31S1P11 PU  ADDR=01,              Station 1, UNITADD=01    *
                ANS=CONTINUE,       *
                PUDR=NO,             *
                PUTYPE=5,            Subarea host node      *
                TGN=1                *
*
A31S1P13 PU  ADDR=03,              Station 3, UNITADD=03    *
                ANS=STOP,            *
                PUDR=YES,            *
                PUTYPE=2              Peripheral host node    *
*
BS1P13L1 LU  LOCADDR=0
```

Figure 4-12. Example: Defining an ESCON Logical Line

## Migrating a System/370 Channel Link to an ESCON Logical Line

You can convert a System/370 channel to an ESCON logical line by updating your NCP system generation definition. The ESCON connection can be a physical line that is directly connected to a host processor, or a physical line that is connected to an ESCD. The ESCD subsequently connects the ESCON link to more than one host processor, thereby enabling two or more existing System/370 channels to be combined into a single ESCON physical line to the ESCD hardware. When consolidating System/370 channels into ESCON channels, consider how the existing channels are to be reassigned so that you maintain a balanced workload.

If the channel links to be migrated are defined on the BUILD definition statement, move the definitions to the GROUP and LINE definition statements. You can use

the migration aid function to do this. Next, define the physical line connected to the ESCON adapter separately from the logical lines to the individual host processor nodes. Code a new physical GROUP definition that specifies LNCTL=CA and code the address of the ESCON adapter on the LINE definition statement.

Define logical links by deleting ADDRESS and CA on the LINE definition statement and adding the HOSTLINK keyword. HOSTLINK values are the logical line numbers used with MOSS-E to define the path of the logical line through the ESCD hardware. The value you code must match the IOCDS and MOSS-E line numbers. ESCON channels support multiple physical units on a logical line. To define more than one physical unit on the same logical line, code a PU definition statement for each device and code the ADDR keyword on the PU definition statement to identify each device number.

**Note:** Logical unit definitions may be coded but are not required for peripheral nodes at generation time. Logical units can be added later using dynamic reconfiguration.

Figure 4-13 shows the definition of an NCP with System/370 channel links. The description following the figure tells you how to convert the channel definition in Figure 4-13 to an ESCON channel definition of the configuration shown in Figure 4-15 on page 4-23.

```

*****
*                               Channel Adapters                               *
*****
A31CAG2  GROUP  CASDL=0.0,          1 *
          DELAY=0.2,                *
          LNCTL=CA,                  *
          MAXPU=16,                  2 *
          PUDR=YES,                  *
          SPEED=144000000,           *
          SRT=(20000,20000),         *
          TIMEOUT=840.0,            *
          TRANSFR=200,               *
*****
* CA ADDR - P5  --  PHYSICAL PORT 5 -- TG=1 CONNECT TO HOST A82          *
*****
A31CP5   LINE  ADDRESS=P5,          3 *
          CA=TYPE7,                 *
          MONLINK=NO
*
A31CP5P  PU    ANS=CONTINUE,        4 *
          PUDR=NO,                  *
          PUTYPE=5,                 *
          TGN=1

```

Figure 4-13 (Part 1 of 2). Example: Converting a System/370 I/O Channel to an ESCON Link (Before)

## Defining ESCON Links

```

*****
* CA ADDR - P6 -- PHYSICAL PORT 5 *
*****
A31CP6 LINE ADDRESS=P6, *
          CA=TYPE7, *
          MONLINK=NO
*
A31CP6P PU ANS=STOP, *
          PUDR=YES, *
          PUTYPE=2
*
B31P6PL1 LU LOCADDR=0
*****
* CA ADDR - P7 -- PHYSICAL PORT 7 -- TG=1 CONNECT TO HOST A17 *
*****
A31CP7 LINE ADDRESS=P7, *
          CA=TYPE7, *
          MONLINK=YES
*
A31CP7P PU ANS=CONTINUE, *
          PUDR=NO, *
          PUTYPE=5, *
          TGN=1
*****
* CA ADDR - P8 -- PHYSICAL PORT 8 *
*****
A31CP8 LINE ADDRESS=P8, *
          CA=TYPE7, *
          MONLINK=NO
*
A31CP8P PU ANS=STOP, *
          PUDR=YES, *
          PUTYPE=2
*
B31P8PL1 LU LOCADDR=0

```

Figure 4-13 (Part 2 of 2). Example: Converting a System/370 I/O Channel to an ESCON Link (Before)

To convert a System/370 channel link definition to an ESCON link definition, make the following changes to the NCP generation definition:

**1** Add the following physical line definition for the ESCON adapter:

```

G31RS0C1 GROUP LNCTL=CA,          Define new channel group for ESCON *
          SPEED=144000000,        *
          SRT=(32768,32768),      *
          XMONLNK=YES             SMMF activates ESCON physical line
*
A31S2240 LINE ADDRESS=2240        New ESCON adapter address *
*
A31P2240 PU ANS=CONTINUE,         Dummy PU for physical connection *
          PUTYPE=1

```

You can also code SPEED, ANS, NPACOLL, and SRT on the GROUP definition statement when you define the physical line. If you code MONLINK=YES on an ESCON logical line definition, code XMONLNK=YES on the physical link station definition; XMONLNK=YES is invalid if you code it on an ESCON logical line definition. Follow the physical line definition with logical link definitions that are associated with the ESCON physical line.

**2** Add PHYSRSC=A31P2240 (the ESCON adapter PU definition statement name) to the logical GROUP definition statement after LNCTL=CA. This creates an association between the physical and logical line definitions.

**3** Replace the 370 I/O channel address with ADDRESS=NONE. Replace the CA keyword on each of the LINE definition statements with a HOSTLINK keyword because the CA keyword is invalid for ESCON channel definitions. HOSTLINK assigns a logical line number to each ESCON link. Each HOSTLINK value corresponds to the logical line number in MOSS-E. Use MOSS-E to associate logical lines with links to host devices.

**4** Code an ADDR keyword on each of the PU definition statements that follow a logical LINE definition to define each physical unit address associated with that line. The ADDR value corresponds to the UNITADD value specified on the IODEVICE definition statement that defines the host device. Notice that when you define an ESCON link, a single link definition can support multiple PU definitions.

Figure 4-14 shows the result of converting the System/370 channel link definition shown in Figure 4-13 on page 4-19 to an ESCON link definition. The two logical lines defined in Figure 4-13 support both subarea host and peripheral host applications. Refer to Figure 4-15 on page 4-23 for an illustration of the channel attachments defined in Figure 4-14.

```

*****
*           PHYSICAL ESCON CHANNEL DEFINITIONS           *
*****
G31RSOC1 GROUP LNCTL=CA,                               1 *
                SPEED=144000000,                       *
                SRT=(32768,32768),                     *
                XMONLNK=YES
*
A31S2240 LINE  ADDRESS=2240                ESCON physical line 2240
*
A31P2240 PU     ANS=CONTINUE,                *
                PUTYPE=1
*****
*           LOGICAL ESCON CHANNEL DEFINITIONS           *
*****
*
*****
*  ESCON LOGICAL RESOURCES ASSOCIATED WITH PHYSICAL LINE 1 (2240)  *
*****
G31LSOC1 GROUP CASDL=0.0,                            *
                DELAY=0.2,                             *
                LNCTL=CA,                               *
                MAXPU=16,                               *
                PHYSRSC=A31P2240,      Associate with physical unit 2 *
                PUDR=YES,                               *
                SPEED=144000000,                       *
                SRT=(20000,20000),                     *
                TIMEOUT=840.0,                         *
                TRANSFR=200

```

Figure 4-14 (Part 1 of 2). Example: Converting a System/370 I/O Channel to an ESCON Link (After)

## Defining ESCON Links

```
*****
*   ESCON LOGICAL LINE 1 GROUP 1 (ESCON PHYSICAL ADAPTER 2240)   *
*****
A31S1L1  LINE  ADDRESS=NONE,                                     *
                HOSTLINK=1,           Host link X'C5'           3 *
                MONLINK=NO
*
A31S1P11 PU  ADDR=01,           Station 1, UNITADD=01           4 *
                ANS=CONTINUE,
                PUDR=NO,
                PUTYPE=5,
                TGN=1
*
A31S1P13 PU  ADDR=03,           Station 3, UNITADD=03           *
                ANS=STOP,
                PUDR=YES,
                PUTYPE=2
*
BS1P13L1 LU  LOCADDR=0
*****
*   ESCON LOGICAL LINE 3 GROUP 1 (ESCON PHYSICAL ADAPTER 2240)   *
*****
A31S1L3  LINE  ADDRESS=NONE,                                     *
                HOSTLINK=3,           LOGICAL LINE 3           *
                MONLINK=YES
*
A31S1P31 PU  ADDR=01,           Station 1, UNITADD=1           *
                ANS=CONTINUE,
                PUDR=NO,
                PUTYPE=5,
                TGN=1
*
A31S1P33 PU  ADDR=03,           Station 3, UNITADD=3           *
                ANS=STOP,
                PUDR=YES,
                PUTYPE=2
*
BS1P33L1 LU  LOCADDR=0           LU for peripheral host node
```

Figure 4-14 (Part 2 of 2). Example: Converting a System/370 I/O Channel to an ESCON Link (After)

## Using MOSS Extended to Configure ESCON Links

Successful definition and activation of ESCON links depends on careful coordination of the NCP generation definition with the IOCDs generation definition that defines I/O hardware devices to the host and MOSS-E. The ESCON Generation Assistant helps to minimize these coordination problems. The example of an NCP generation definition for ESCON links shown in Figure 4-14 on page 4-21 must match information defined in the IOCDs generation definition.

Figure 4-16 on page 4-24 shows how the LINK keyword value on the CNTLUNIT definition statement in the IOCDs generation definition corresponds to the HOSTLINK value coded on the LINE definition statement in the NCP generation definition. The UNITADD keyword value on the IODEVICE definition statement matches the ADDR keyword value on the PU definition statement.

Once you define the logical lines to NCP, the same logical line numbers are identified to MOSS-E. MOSS-E executes in a dedicated PS/2 to provide support for

ODLC maintenance functions. Figure 4-16 on page 4-24 (Part 2) shows an example of the MOSS-E ESCA Link Information panel where the MOSS-E console operator enters ESCON Director link addresses for the logical lines. The numbers entered in the panel correspond to the logical line numbers (1 to 32) defined by HOSTLINK keywords in the NCP generation definition. For example, host link 1 attached to the ESCON coupler (ESCC) on line 2240 is assigned host link address C5-0.

If you want to IPL over an ESCON link, choose YES on the MOSS-E IPL option, code MONLINK=YES on the logical line definition, and code XMONLNK=YES on the physical line definition. See page 4-14 for a description of how to code MONLINK and XMONLNK values for an ESCON connection.

The ESCON Generation Assistant helps to coordinate the NCP generation definition with the IOCDs generation definition and MOSS-E. It provides online help and examples to assist you when you define your ESCON configuration. You can also refer to MOSS-E online help for information about how to enter link addresses for logical lines.

Figure 4-15 shows the ESCON channel configuration defined in the NCP generation definition in Figure 4-14 on page 4-21.

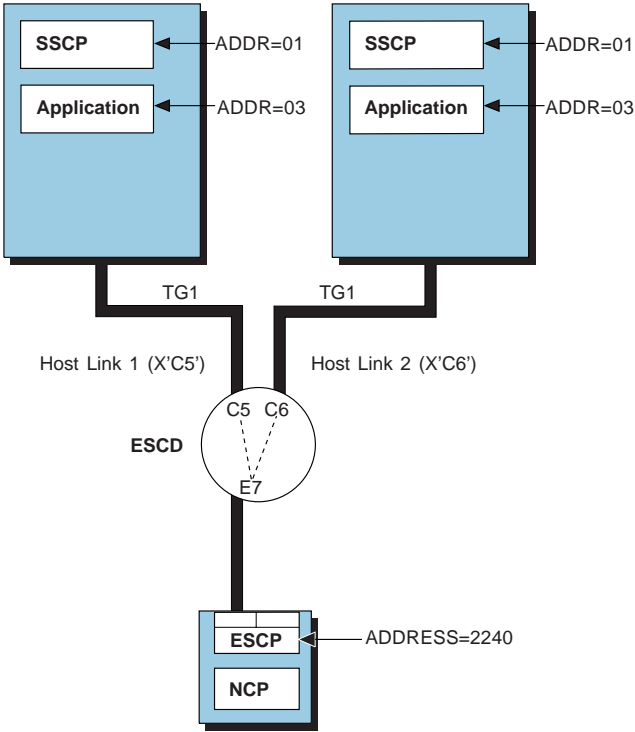

Figure 4-15. ESCON Channel Configuration (with LINE and STATION Addresses)

# Defining ESCON Links

## IOCDS Generation Definition

CHPID	PATH=01, SWITCH=01
CNTLUNIT	CUNUMBER=0155, PATH=01,
	LINK=E7,
	CUADD=0
IODEVICE	ADDRESS=014D, CUNUMBER=0155,
	UNITADD=01
IODEVICE	ADDRESS=0222 CUNUMBER=0155,
	UNITADD=03

## NCP Generation Definition

GROUP LINE	ADDRESS=2240
GROUP LINE	ADDRESS=NONE
	HOSTLINK=1,
	MONLINK=NO
PU	ADDR=01, <sup>1</sup>
	ANS=CONTINUE, PUDR=NO, PUTYPE=5, TGN=1
PU	ADDR=03, <sup>1</sup>
	ANS=STOP, PUDR=YES, PUTYPE=2
LINE	ADDRESS=NONE
	HOSTLINK=2,
	MONLINK=NO
PU	ADDR=01,
	ANS=CONTINUE, PUDR=NO, PUTYPE=5, TGN=1
PU	ADDR=03,
	ANS=STOP, PUDR=YES, PUTYPE=2

<sup>1</sup> Each line has an individual station panel.

Figure 4-16 (Part 1 of 2). Relationship between IOCDS, NCP, and MOSS-E



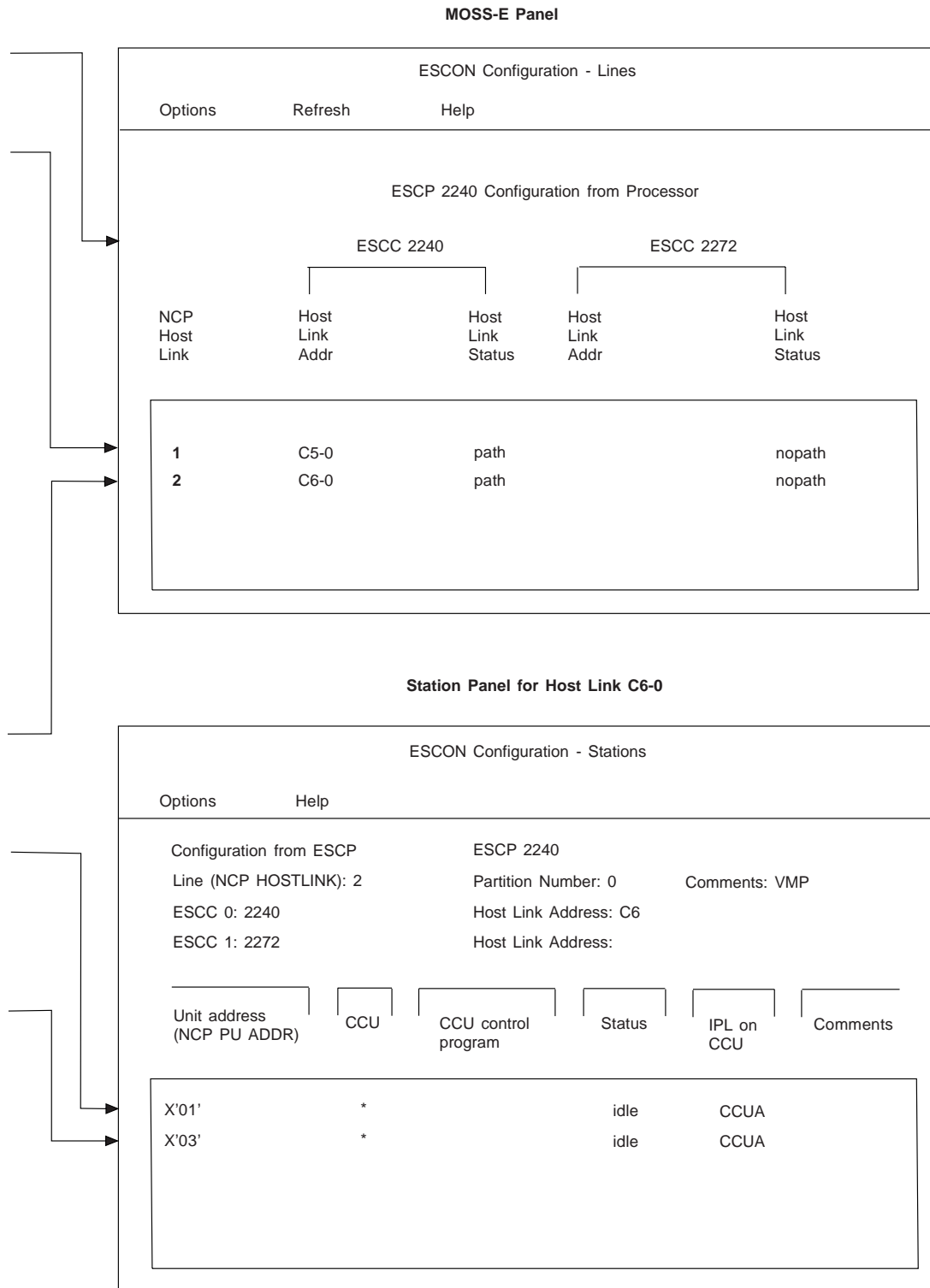

Figure 4-16 (Part 2 of 2). Relationship between IOCDs, NCP, and MOSS-E

---

### Defining Subarea Addressing Limits

Networks are able to communicate with subareas when addresses are assigned to the subarea and a route is defined to that subarea. Code the following definition statements and keywords to provide NCP with the assigned subarea address and information about the upper limits of available subarea addresses.

BUILD	MAXSUBA SALIMIT SUBAREA
NETWORK	SALIMIT

#### BUILD

MAXSUBA specifies the largest subarea resource address used by NCPs that do not have extended network addressing ability within the network. The MAXSUBA value must match the MAXSUBA values coded on all other NCPs and access methods in the same network. If all nodes in your network are capable of extended network addressing, do not code MAXSUBA. Extended network addressing is supported by all releases of NCP.

**Note:** Unless all nodes in your network are capable of extended network addressing, MAXSUBA is required.

SALIMIT specifies the largest subarea address in the native network. If you omit SALIMIT, NCP supports as many as 255 subarea addresses. An SALIMIT value is needed only if you require subarea addresses greater than 255.

SUBAREA specifies the subarea address that is to be assigned to NCP or PEP. It cannot exceed the value coded on SALIMIT. Each subarea in a network must have a unique address, with the following exceptions:

- A subarea defined in one domain can have the same address as a subarea in another domain if the two domains never communicate with one another.
- Multiple access methods in a system configuration can have the same address if only one communicates with the network at a time.

#### NETWORK

SALIMIT on the NETWORK definition statement specifies the largest subarea address in the non-native network. If you omit SALIMIT, NCP supports as many as 255 subarea addresses. An SALIMIT value is needed only if you require non-native subarea addresses greater than 255.

#### Sample Definition of a Subarea Address

Figure 4-17 on page 4-27 shows how to establish addressability for an NCP subarea. The subarea, assigned an address of 3, supports up to 16 explicit route definitions and as many as 1023 addresses for other subareas in the native network (NETA) and the non-native network (NETB).

```

A03N415 BUILD ERLIMIT=16,      16 explicit routes defined
           MAXSUBA=255,      255 subarea addresses allowed
           NETID=NETA,      NETA is name of native network
           SALIMIT=1023,    Largest subarea address
           SUBAREA=3,      Subarea address assigned to NCP
           .
           .
           .
*****
*          NON-NATIVE NETWORK NETB DEFINITIONS          *
* (ERLIMIT defaults to the value coded on the BUILD definition *
* statement.)                                           *
*****
*
NETB      NETWORK NETID=NETB,    Name of non-native network
           SALIMIT=1023,      Largest subarea address
           .
           .
           .
*

```

Figure 4-17. Example: Defining Subarea Addressability

## Maximum Number of Concurrent Sessions and Routes

There are limits to the number of sessions and routes that NCP can support concurrently. The maximum number of sessions and routes includes:

- The number of SSCPs in session with NCP concurrently over a combination of channel links and subarea links
- The number of subareas with routes to NCP
- The number of virtual routes available to NCP.

Code the following definition statement and keywords to provide NCP with information about the maximum number of concurrent sessions supported by NCP.

```

BUILD      MAXSSCP
           NUMHSAS
           VRPOOL

```

MAXSSCP on the BUILD definition statement specifies the maximum number of SSCPs in session with NCP. NCP can be in session with as many as eight SSCPs. Remember that if you code MONLINK=CONTINUOUS on the LINE definition statement that defines a subarea link, SMMF continuously monitors the link and acts as an SSCP in continuous session with NCP. This continuous session reduces the number of available SSCP sessions by one and must be considered when coding a number for MAXSSCP.

NUMHSAS defines the expected number of NCP and host subareas in the network that can communicate with NCP. Although the maximum value is 65534, limit the value to the number of host and NCP subareas with virtual routes ending in this NCP so that you do not waste NCP storage.

## Dynamic Control Facilities

### Notes:

1. NCP can activate virtual routes for sessions between independent logical units. NCPs attached to type 2.1 nodes should be included in the number of NCP subareas with virtual routes ending in this NCP.
2. The NUMHSAS value on the BUILD definition statement gets added to the NUMHSAS values on the NETWORK definition statements. NCP does not keep a separate resource pool for each network.

VRPOOL defines how many virtual route control blocks are available for concurrent activation in NCP. Consider the number of defined virtual routes ending in this NCP plus additional resources needed when a virtual route fails. Extra virtual route entries make a fast restart possible because cleanup of a failed virtual route has a lower priority than virtual route restart. The maximum value for VRPOOL is 65532; however, an excessive number of virtual route pool entries wastes NCP storage.

VRPOOL also defines the number of extra flow parameter table rows used in the dynamic path update function. See “Dynamic Path Update” on page 11-13 for more information.

If you define a gateway NCP, the VRPOOL value should include virtual routes from non-native networks. For more information about gateway NCPs and interconnected networks, see Chapter 14.

### Sample Definition of Concurrent Sessions to NCP

Figure 4-18 shows how to define the maximum number of concurrent SSCP sessions, subarea sessions, and virtual routes.

A03N415	BUILD	MAXSSCP=8,	8 concurrent SSCPs defined
		NUMHSAS=8,	8 subareas defined for this NCP
		VRPOOL(5,5)	5 entries in virtual route pool

Figure 4-18. Example: Defining Concurrent Sessions

---

## Dynamic Control Facilities

NCP makes many dynamic control facilities available to you when they are requested in the system generation definition. Dynamic control facilities enable NCP to handle requests from the access method to change certain NCP parameters or determine the status of resources such as telecommunication links or terminals. A comprehensive list of these facilities, as well as directions for determining which facility is appropriate for your configuration, can be found in *NCP, SSP, and EP Resource Definition Reference*. *TCAM Base Installation Guide* also provides information on the dynamic control facilities available with each access method.

Code the following definition statement and keyword to provide NCP with the names of individual dynamic control features to be used.

SYSCNTRL	OPTIONS
----------	---------

OPTIONS on the SYSCNTRL definition statement enables you to activate individual dynamic control facilities available in NCP.

---

### Defining NCP to VTAM

Use the PCCU definition statement and its keywords if VTAM is to activate NCP. These keywords provide VTAM with information on NCP and the communication controller in which it resides. See *VTAM Resource Definition Reference* for a complete description of PCCU and its keywords.



---

## Chapter 5. NCP and Link-Attached Devices

Your NCP system generation definition defines many physical and operational characteristics about the relationship between NCP and its link-attached devices. This chapter describes how to define these characteristics.

---

### Nonswitched Telecommunication Links

Nonswitched telecommunication links are lines on which connections do not have to be established by dialing. Channel links are channels connected to channel adapters. See Chapter 4 for more information on channel links. See “How You Define Resources to NCP” on page 1-4 for information about the order of line group definitions in a generation definition.

**Note:** You can attach SDLC lines to NCP through the 3746 Model 900 connectivity subsystem. The 3746 Model 900 improves NCP performance by performing NCP data link control processing. To use the 3746 Model 900 you need to obtain a license for the NCP 3746 Model 900 Feature from IBM. Be sure to define 3746 Model 900 SDLC lines and TSS or HPTSS SDLC lines attached to the IBM 3745 in separate groups. You cannot define both 3746 Model 900 SDLC lines and 3745-attached SDLC lines under the same GROUP definition statement. For more information, see “Converting Existing SDLC Resources to 3746 Model 900 SDLC Resources” on page 5-21.

Code the following definition statements and keywords to provide NCP with information about how to manage the resources and improve performance.

GROUP	LEVEL2 LEVEL3 LNCTL RNRLIMIT TYPE
LINE	ADDRESS CLOCKNG DUPLEX HISPEED LNQTCNT MONITOR SPEED TYPE
PU	MODULO

#### GROUP

LEVEL2 and LEVEL3 on the GROUP definition statement specify the appropriate entry points for user-written line control code.

LNCTL enables you to define the type of line control used for one or more links in a line group. Line control defines the data link control or medium access control (MAC) protocol used to exchange data and control information with a device.

## Nonswitched Telecommunication Links

RNRLIMIT specifies the interval a given station has to reject data before NCP identifies the station as inoperative. A station is considered inoperative if it responds with a receive-not-ready (RNR) command to data or a poll sent by NCP during the interval defined.

TYPE specifies the operating mode of the line group and the individual line. The operating mode determines how the line within a group, and the devices attached to the line, are to be managed by NCP. Valid operating mode types are network control mode (TYPE=NCP), emulation mode (TYPE=EP), or both (TYPE=PEP).

**Note:** A group consisting of SDLC links operates only in network control mode. NCP treats peripheral devices attached using a LAN architecture as SDLC devices; therefore, the only valid mode for Token-Ring or Ethernet-type LAN-attached devices is network control mode.

### LINE

ADDRESS on the LINE definition statement specifies the relative line number of the lines attached to the communication controller. It can also specify whether data is transferred across the link in half-duplex or duplex mode. If the link operates in emulation mode, ADDRESS specifies the relative line number and the address of the emulation subchannel that supports the link. See *NCP, SSP, and EP Resource Definition Reference* for a complete range of values for nonswitched links.

**3746 Model 900 SDLC Lines:** Code a line number greater than 2048.

CLOCKNG identifies one of the following clocking methods to be used:

- External clocking is provided by a modem or other attached device, whether the device is in a separate unit or built into the controller.
- Internal clocking, known as *business machine clocking*, is provided by a communication scanner.
- Direct clocking, a variation of controller-provided clocking, is provided by the scanner, which propagates it to the data terminal equipment (DTE).

If you use direct clocking, use a direct-attached cable and code the SPEED keyword. If you are using an X.21 interface (LIC type 4) but are *not* accessing the X.21 network (X21INTWK=NO on the GROUP definition statement) code CLOCKNG=(EXT,LIC) and code the SPEED keyword. If you code CLOCKNG=EXT and omit LIC, you do not need to code the SPEED keyword unless:

- NPM data is being collected for this line
- The line is a 3746 Model 900 SDLC line.
- The line is an SDLC peripheral line that supports APPN HPR data.

DUPLEX describes the transmission characteristics of the physical communication path, including common-carrier lines and equipment and the modems at both ends of the path. The communication path is either a two-wire (half-duplex) or four-wire (duplex) circuit. Be careful not to confuse this with half-duplex or duplex data transfer mode, which is determined by the ADDRESS keyword coded on the LINE definition statement and DATMODE coded on the PU definition statement. A two-wire circuit link cannot necessarily transfer data in half-duplex mode. If the clear-to-send (or ready-for-sending) signal lead in the modem is continuously energized, the two-wire half-duplex circuit transfers data in duplex mode.



HISPEED specifies the speed to be used on low-speed scanner (LSS) lines. Code HISPEED=YES to specify that LSS lines, using SDLC or BSC line control and operating in network control mode, operate at 144 Kbps or greater.

LNQTCNT defines how many times NCP tests start-stop links to ensure that there is no electrical activity before the next transmission begins. Code LNQTCNT only when you define start-stop lines.

MONITOR specifies whether NCP is to monitor the link for an attention signal or a disconnect condition at the terminal. If so, NCP monitors the link regardless of whether NCP is executing a command for that link. NCP notifies the access method if it detects an attention signal or a disconnect condition. Include this option if terminals attached to the link communicate with TSO applications, or if a start-stop link has IBM 1050 Data Communication System terminals, IBM 2741 Communication Terminals, TWX terminals, or MTA terminals attached.

SPEED sets the data rate for the link, which is the rate at which devices attached to the link send and receive data. SPEED also provides information about NPM data collection.

### Notes:

1. Do not overload the transmission capability of the line interface coupler (LIC) or the communication controller by exceeding the maximum LIC weight supported. For more information see *Connection and Integration Guide* for your IBM 3745 Communication Controller model.
2. If you use the X.21 interface, you can include the SPEED keyword even if you are not using X.21 modems.

**3746 Model 900 SDLC Lines:** Code SPEED for each 3746 Model 900 SDLC line.

**APPN HPR:** NCP uses the value of the SPEED keyword to determine the rate of flow for APPN HPR data on SDLC peripheral lines. Code the SPEED keyword for SDLC peripheral lines that support APPN HPR data to ensure that the APPN HPR flow control mechanism works correctly.

Starting with VTAM V4R4 and NCP V7R6, the CAPACITY value from VTAM's topology database is used to determine link capacity and transmission time instead of the SPEED keyword. The value coded on the SPEED keyword is still used for earlier versions of VTAM and NCP.

TYPE defines whether the single BSC or start-stop link operates:

- Only in network control mode (TYPE=NCP)
- Only in emulation mode (TYPE=EP)
- Alternately in either network control mode or emulation mode (TYPE=PEP)

If you code TYPE=NCP, code the keywords discussed in this chapter but not those in Chapter 20 or in Chapter 21. If you code TYPE=EP, see Chapter 20, "BSC and Start-Stop Devices Operating in PEP Environment" on page 20-1. If you code TYPE=PEP, code the keywords discussed in this chapter and those discussed in Chapter 20.

## Switched Links

### PU

MODULO on the PU definition statement specifies whether the link operates as a modulo-8 or a modulo-128 link. If the link operates as a modulo-8 link, NCP sends up to seven information frames (I-frames) to the device attached to the link before a response indicating whether the device received the I-frames is required. If you specify that the link operates as a modulo-128 link, NCP sends up to 127 I-frames to the attached device before a response is required.

For a modulo-128 link, the mode of the link depends on the MAXOUT value on the PU definition statement. If you code MODULO=128 and specify a value of 8 or greater for MAXOUT, the link operates as a modulo-128 link. If you code MODULO=128 and specify a value of 7 or less for MAXOUT, the link operates as a modulo-8 link.

### Sample Definition of a Nonswitched Telecommunication Link

Figure 5-1 shows how to define a nonswitched link.

GA03SDL1	GROUP	LNCTL=SDLC, TYPE=NCP	SDLC line control Lines operate in network control mode
*			
L00321	LINE	ADDRESS=021, CLOCKNG=EXT, DUPLEX=FULL	Relative line number Modem provides clocking Duplex line
*			
P00321A	PU	.	
		.	
		.	

Figure 5-1. Example: Defining Nonswitched Telecommunication Links

---

## Switched Links

This section describes how to define switched links, which use a dial-up process to establish a connection between the communication controller and a remote device. It includes a description of the V.25 bis dial process and tells you how to define a limited resource session.

Code the following definition statements and keywords to provide NCP with information about how to manage the dial-up link and improve performance. Code these definition statements and keywords in addition to the definition statements and keywords found in "Nonswitched Telecommunication Links" on page 5-1.

DIALSET	DIALALT LINES QLIMIT QLOAD RESERVE
GROUP	DIAL RETRYTO XMITDLY X21NTWK
LINE	AUTO AUTODL CALL CCLID DIALSET MPTALT REDIAL SECURE SPEED

## DIALSET

DIALALT on the DIALSET definition statement identifies the definition statement that names an alternate dial set. A dial set is a group of switched BSC or start-stop links from which NCP selects a link to call a specific device. It can contain any number of links that have similar characteristics. The alternate dial set is defined on a second DIALSET definition statement immediately following the DIALSET statement that contains the DIALALT keyword. The alternate dial set must have the same type of BSC or start-stop links as the primary dial set. Code the DIALSET definition statement only when you define BSC or start-stop devices.

LINES identifies the BSC or start-stop links that make up a dial set. The name of each link is the name of a corresponding LINE definition statement that defines the link.

QLIMIT defines the maximum number of requests NCP is to collect on the queue for the dial set. When this limit is reached, NCP rejects any further callout requests it receives. It continues to do this until the number of queued requests becomes less than the QLIMIT value. If you specify a queue limit of 0, NCP rejects any callout sequence it cannot immediately service.

QLOAD specifies the number of callout requests NCP is to collect on the queue for the dial set before using a BSC or start-stop link from the alternate dial set. Code a number that is smaller than the QLIMIT value. A larger number will cause callout requests to be rejected before they can be routed to an alternate dial set.

RESERVE specifies the number of BSC or start-stop links in the dial set reserved for incoming calls from devices. You need RESERVE only if all the links in the dial set are designated as available for both incoming and outgoing calls, and all the links could become occupied with outgoing calls, thus preventing any device from calling NCP.

### GROUP

DIAL on the GROUP definition statement specifies whether the links in the group require switched line control procedures. Code DIAL=YES for a switched link.

RETRYTO, valid only for X.21 lines, defines the length of time NCP is to wait after receiving a *retry call progress signal* on this SDLC link before retrying a callout operation. NCP supports a maximum of 1632 seconds.

XMITDLY defines the amount of time NCP is to delay its initial transmission after answering an incoming call on this SDLC link. This delay gives the calling station time to transmit first, and lets the modems complete any required equalization in the inbound direction prior to the first NCP transmission.

You can also use XMITDLY as the reply timeout value if it is longer than the REPLYTO interval and XIDs are exchanged. When XIDs are not exchanged, the reply timeout interval is the value coded for REPLYTO on the GROUP definition statement.

X21NTWK specifies that hardware conforming to the CCITT X.21 standard is attached to each SDLC link in the group. X21NTWK specifies an attachment to an X.21 network and the level of the X.21 network.

### LINE

AUTO on the LINE definition statement specifies whether a logical automatic calling unit (ACU) is installed on the link, or it specifies the relative line number of the ACU line used to send dial digits and establish an outgoing connection. See "V.25 Bis" on page 5-7 for more information about V.25 bis modems and connections.

**3746 Model 900 SDLC Lines:** Do not code a line number on the AUTO keyword.

AUTODL specifies that the hardware accepts dial digits only if hardware conforming to the CCITT X.21 standard is attached to the SDLC link. If dial digits are accepted, NCP carries out normal callout procedures for this link. If dial digits are not accepted, but the direct-call feature is installed, NCP can connect to a link-attached device without transmitting dial digits.

CALL specifies whether the line is for incoming calls, outgoing calls, or both. For SDLC links, CALL provides information only to the VTAM initialization procedure and has no effect on the NCP generation. See *VTAM Resource Definition Reference* for information on using CALL.

CCLID initiates X.21 called-calling-ID (CCLID) support.

DIALSET specifies a value that is the label value of the DIALSET definition statement for this line. Code DIALSET if the BSC line is point-to-point and NCP calls the devices. Allow DIALSET to default if the line is used only for incoming calls.

MPTALT specifies whether the BSC link is a callout link that can be used as an alternate link for communicating with BSC devices usually reached over a non-switched multipoint link. If failure of the multipoint link prevents NCP from communicating with a device over that link, the switched network backup facility can reach the station over any link that you specify as an alternate link.

REDIAL defines the maximum number of dialing operations NCP is to perform to reach a device over a switched link. REDIAL also defines the duration of the pause between dialing operations.

SECURE specifies whether NCP is to use the secure option for the start-stop link. Code SECURE=YES when the start-stop link is a duplex link. SECURE=YES prevents access to program data by a start-stop device that dials the communication controller over this link at the moment the existing connection to a different device is lost. If you include this option, NCP continuously monitors the data carrier detect signal from the modem to give positive assurance that the switched connection is still established.

SPEED sets the data rate for this link, which is the rate at which devices attached to the link send and receive data. SPEED also provides information about NPM data collection.

**3746 Model 900 SDLC Lines:** Code SPEED for each 3746 Model 900 SDLC line.

**APPN HPR:** NCP uses the value of the SPEED keyword to determine the rate of flow for APPN HPR data on SDLC peripheral lines. Code the SPEED keyword for SDLC peripheral lines that support APPN HPR data to ensure that the APPN HPR flow control mechanism works correctly.

Starting with VTAM V4R4 and NCP V7R6, the CAPACITY value from VTAM's topology database is used to determine link capacity and transmission time instead of the SPEED keyword. The value coded on the SPEED keyword is still used for earlier versions of VTAM and NCP.

### Sample Definition of a Switched Link

Figure 5-2 shows how to define a switched link.

GA03SDL6 GROUP	DIAL=YES, LNCTL=SDLC, REPLYTO=15.0, TYPE=NCP	Switched lines SDLC line control Reply timeout value Lines operate in network control mode
*		
L00324 LINE	ADDRESS=024, AUTO=030, CALL=INOUT, CLOCKNG=EXT, DUPLEX=FULL	Relative line number Relative line number of auto call unit Incoming and outgoing calls Modem provides clocking Duplex line
*		
P00324A PU	.	
	.	
	.	

Figure 5-2. Example: Defining Switched Telecommunication Links

## V.25 Bis

The V.25 bis dial protocol uses a technique called serial automatic calling. This method uses the same line to send dial digits during the call establishment phase and to send and receive data during the data transfer phase. This contrasts with dialing methods that use two physical lines, one to establish the connection and one to transmit data.

V.25 bis protocol supports three types of line control in network control mode: SDLC, start-stop, and BSC. However, the actual dial connection must be made in

## Switched Links

SDLC or start-stop mode. The V.25 bis dial protocol is supported for emulation mode lines, but only in start-stop mode.

**Note:** The type of dial connection protocol to be supported is determined by your modem.

With the V.25 bis dial protocol, dial-out failures are reported to the NetView program using generic alerts instead of record maintenance statistics (RECMS). Generic alerts identify possible causes of the dial-out failure. Because EP cannot send alerts, dial-out failures on lines operating in emulation mode are not reported until the next dial host command is received.

Code the following definition statements to provide NCP with information about how to manage the calling process and dial protocol.

GROUP	DIAL LNCTL PRODID
LINE	AUTO CALL REDIAL RING V25BIS
TERMINAL	DIALNO

DIAL on the GROUP definition statement specifies whether the lines in this group require switched line control procedures. Code DIAL=YES for a V.25 bis connection.

LNCTL specifies whether SDLC, BSC, or start-stop line control is to be used.

PRODID specifies the name of the product identifier subvector (X'11') for IBM special products or user-written code. IBM special products or user-written code must define subvector X'11' as follows:

- The first byte must contain the length of the subvector.
- The second byte must contain X'11'.
- The remainder of the subvector field contains the identifier of the IBM special products or user-written code.

If PRODID is specified, subvector X'11' will appear in the generic alert generated for a dial-out failure. PRODID is valid only for IBM special products or user-written code.

AUTO on the LINE definition statement specifies whether automatic calling is to be used for V.25 bis protocol. Code AUTO=YES for V.25 bis even though an automatic calling unit (ACU) is not connected.

**3746 Model 900 SDLC Lines:** Code AUTO=YES for V.25 bis 3746 Model 900 SDLC lines.

CALL specifies whether the line is for incoming calls, outgoing calls, or both. Code CALL=OUT or CALL=INOUT for V.25 bis.

REDIAL defines the maximum number of dialing operations NCP is to perform to reach a device over a switched line. If you omit REDIAL for V.25 bis, NCP makes only one attempt to dial the device.

RING specifies ring-indicator mode. Code RING=YES for V.25 bis.

V25BIS defines modem support for the V.25 bis protocol and identifies the line control protocol for the dial operation (SDLC or start-stop). Once a connection is established, the line runs in the mode defined by the LNCTL keyword.

DIALNO on the TERMINAL definition statement specifies the telephone number used by NCP to call the device defined by the TERMINAL definition statement.

### Sample Definition of V.25 Bis

Figure 5-3 on page 5-10 shows how to define the V.25 bis protocol for a start-stop line with a start-stop modem and an SDLC modem. This example contains many keywords that are explained in other sections of the book; however, they have been included in this example for completeness. See “Devices Attached to NCP” on page 5-26 and “Data Characteristics” on page 5-43 in this chapter or the following topics for more information on these additional keywords:

- Chapter 9, “Block Handlers” on page 9-1
- “Timeouts” on page 20-7
- “Switched Lines” on page 21-15
- Chapter 18, “Teletypewriter Exchange Service” on page 18-1
- Chapter 24, “Network Performance” on page 24-1

```

*****
*           DIALSET FOR CALLOUTS TO TWX DEVICES           *
*****
*
SWITWX06 DIALSET LINES=LTWX06R,      Lines using this dialset
                QLIMIT=0              Don't allow multiple callouts
*
*****
*           SWITCHED START-STOP LINK TO TWX DEVICES       *
*****
*
GSSNTOR  GROUP  ATTN=ENABLED,        Accept terminal attention signal
                CHAREC=(XOFF,8D),    Message ending characters
                CODE=ASCII,          Transmission code to be used
                DIAL=YES,             Switched line control
                LNCTL=SS,             Start-stop line control
                REPLYTO=23.5,         Timeout value for line group
                TEXTTO=23.5,         Text timeout value for line group
                TYPE=NCP              Network control mode
*
LTWX06R  LINE   ADDRESS=006,         Relative line number
                AUTO=YES,            Automatic calling device assumed
                CALL=INOUT,          Incoming and outgoing calls specified
                CLOCKNG=EXT,         Modem provides clocking
                CODE=ASCII,          ASCII transmission code
                DIALSET=SWITWX06,    Reference to dial set definition
                DUPLEX=HALF,         Half-duplex line transmission
                ISTATUS=INACTIVE,    VTAM-only keyword
                MONITOR=YES,         Monitor for attention signal/disconnect
                REDIAL=1,            Number of redial operations
                RETRIES=(3,1,2),     3 recovery attempts
                RING=YES,            Use ring-indicator mode of auto answer
                TERM=TWX,             Communicate with TWX device
                USE=NCP,             Network control mode specified
                V25BIS=(YES,DLSS)    V.25 modem using start-stop protocol
*
TWX06D   TERMINAL  BHSET=HEDIT16,    Specify name of block handler set
                CRDLAY=YES,         Delay processing of write operation
                CTERM=YES,          Definition of devices calling controller
                TERM=TWX,           Device type specified
                FEATURE=(NOBREAK,ATTN) Break signal disallowed, attention
                                     signal allowed

```

Figure 5-3. Example: Defining V.25 Bis

### Limited Resource Sessions

When a session communicates over a switched link, it can be defined as a limited resource session. A limited resource session permits a logical unit to automatically deactivate a limited resource session without operator intervention as soon as there is no more session data traveling over the link.

Code the following definition statement and keyword to provide NCP with the authorization to support these sessions.

LINE	LIMRES
------	--------



LIMRES on the LINE definition statement specifies that the line supports limited resource sessions.

---

## Shared Port Identification

Before a node and NCP communicate, VTAM must determine whether the node and NCP can exchange information. VTAM compares the name of the node, contained in the XID field, against a list of node names that it maintains. This list indicates which nodes can communicate with NCP. VTAM creates the list from information found on the PU definition statements in the VTAM switched major node definition. Each PU definition statement represents one node that can exchange data with NCP. Because many nodes in a network communicate with NCP, there may be many PU definition statements in the VTAM switched major node definitions.

Network design permits more nodes that can communicate with NCP than there are NCP ports through which the nodes can pass data. Thus, many nodes share ports. Shared port identification lets you assign a name to the NCP port through which the node communicates and defines ports in the VTAM switched major node. Shared port identification lets VTAM compare the NCP node name against its list of port names. This sharing capability lessens the amount of comparing VTAM must do, and, therefore, the number of PU definition statements required in the VTAM switched major node definition.

Refer to *VTAM Network Implementation Guide* for information on how you describe ports in the VTAM switched major node.

When all the ports have names and are fully defined by PU definition statements in the VTAM switched major node definition, a node and NCP communicate in the following manner:

1. A node calls NCP to initiate communication.
2. NCP exchanges the node name (found in the node XID) with the port name and sends the port identification to VTAM.
3. VTAM checks the port identification against its list of port names.
4. If VTAM identifies the port as one that can communicate with NCP, VTAM sends NCP permission to exchange data.
5. If the port name does not appear on the list, VTAM denies permission to NCP.

Code the following definition statement and keyword to provide NCP with the port identification number.

LINE	ID
------	----

ID on the LINE definition statement identifies the hexadecimal port number NCP exchanges for the name of the node calling NCP through the port. Be sure the number you choose for ID is unique within the network. ID must correspond to the IDNUM and IDBLK keywords of the PU definition statement in the VTAM switched major node definition. Read *VTAM Resource Definition Reference* for information on coding VTAM switched major nodes.

## SSCP Monitor Mode Function

**Attention:** When NCP processes a request, it substitutes the port identification you code for the node identification in the received XID before passing the XID to the host for station identification. When you code ID, network awareness terminates at the port. Also, the security provided when the host verifies the node name is not possible. Therefore, security must be provided at the application level.

---

## SSCP Monitor Mode Function

You can activate SDLC subarea links or peripheral links using the SSCP monitor mode function (SMMF). SMMF enables an NCP that is not in session with an SSCP to activate subarea links to other communication controllers and peripheral links connected to non-type 4 physical units. Use SMMF to activate a subarea link that performs a remote load or dump. See “Remote Loading and Activation of a Link-Attached NCP” on page 12-29 for more information.

SMMF must be able to activate at least one subarea link, channel link, channel link station, or ESCON link defined in your system generation definition or the NCP generation process will fail.

The following sections describe how to use SMMF for different types of links.

### SMMF for Nonswitched SDLC Subarea Links

You can use SMMF to activate a remote controller over nonswitched SDLC subarea links. Code the following definition statement and keyword to provide NCP with information about the nonswitched subarea link to be activated.

LINE	MONLINK
------	---------

MONLINK on the LINE definition statement specifies whether SMMF is to activate and monitor subarea links with attached type 4 physical units. SMMF will continuously monitor the link if you code MONLINK=CONTINUOUS, even if an external SSCP gains ownership of NCP. When SMMF continuously monitors a link, NCP permits a maximum of seven other owners for that link.

**Note:** You can also activate Token-Ring subarea links and frame-relay subarea links using SMMF.

### Sample Coding for SMMF to Activate a Nonswitched SDLC Subarea Link

Figure 5-4 on page 5-13 shows sample coding to define SMMF for a nonswitched SDLC subarea link. Although SMMF activates the link, it releases the link when an external SSCP takes ownership of the NCP.

```

G25SNAL2 GROUP LNCTL=SDLC,      SDLC line control
                TYPE=NCP        Lines operate in network control mode
*
L251028 LINE ADDRESS=(1028,FULL), Relative line number
                MONLINK=YES     SMMF activates link
*
P251028A PU   PUTYPE=4,        Physical unit type
                .
                .
                .

```

Figure 5-4. Example: Defining SMMF for a Nonswitched SDLC Subarea Link

### SMMF for Switched SDLC Subarea Links

Using SMMF, you can activate a remote controller attached to a switched subarea link. If SMMF monitors a switched subarea link, identify valid calling stations by building switched SMMF tables and providing pointers to those tables.

Code the following definition statements and keywords to provide NCP with information about the switched subarea link to be activated and the SMMF table.

```

SWMMT          IDNUM
                MAXDATA
                MAXOUT
                NETID

LINE           MONLINK
                SWMMTID

```

### SWMMT

IDNUM on the SWMMT definition statement provides unique identification of each network. IDNUM is used for sender or receiver verification on each link. If you code IDNUM, it must match the number of the sending station in the VTAM switched major node.

**Note:** Call verification security is not supported for SMMF.

MAXDATA limits the maximum amount of data the link sends or receives in one data transfer. Code MAXDATA to minimize the coordination problems among different line types if the line is part of a mixed-media MLTG. The limit you specify includes one PIU or PIU segment and header information. See “MLTG Segment Size” on page 12-23 for more information about how to calculate the correct MAXDATA value for a line in a mixed-media MLTG.

MAXOUT specifies the number of PIUs that can be sent before NCP requests a response.

NETID identifies the network that contains the adjacent link station. The NETID name on the SWMMT definition statement must match the NETID name on the NETWORK definition statement for that network.

## SSCP Monitor Mode Function

### LINE

MONLINK on the LINE definition statement specifies whether SMMF is to activate and monitor subarea links with attached type 4 physical units.

SWMMTID identifies the switched SMMF table. Code SWMMTID only for switched subarea links. The name you assign to SWMMTID must also appear on the first SWMMT definition statement.

**Note:** If you code SWMMTID, you must code MONLINK=CONTINUOUS or MONLINK=YES.

### **Sample Coding for SMMF to Activate a Switched SDLC Subarea Link**

Figure 5-5 on page 5-15 shows sample coding to define a switched SDLC subarea link using SMMF. The sample coding includes an SMMF table with three entries. The first two entries are for links to subareas in network NETB and the third entry is for a link to a subarea in the native network.

```

        BUILD NETID=NETA,...
*
        SYSCNTRL .
                .
                .
*
SDLPRI  SDLCST GROUP=GRPPRI,
        MODE=PRI
*
SDLSEC  SDLCST GROUP=GRPSEC,
        MODE=SEC
*
SWMTAB  SWMMT IDNUM=12345,
        NETID=NETB,
        MAXOUT=5
        SWMMT IDNUM=67890,
        NETID=NETB,
        MAXOUT=5
        SWMMT IDNUM=ABCD
*
*
*
*
GRPPRI  GROUP LNCTL=SDLC,
        DIAL=NO,
        MODE=PRI
*
GRPSEC  GROUP LNCTL=SDLC,
        DIAL=NO,
        MODE=SEC
*
GRPCON  GROUP LNCTL=SDLC,
        DIAL=YES,
        PUTYPE=4,
        SWMMTID=SWMTAB
*
L1      LINE  IPL=YES,
        MONLINK=CONTINUOUS,
        SDLCST=(SDLPRI,SDLSEC),...
*
L1PU1  PU
*
L2      LINE  MONLINK=YES,...
*
L2PU1  PU
        .
        .
        .

```

If NETID omitted on SWMMT, it defaults to the native network  
If MAXOUT omitted on SWMMT, it defaults to 7

Figure 5-5. Example: Defining a Switched SDLC Subarea Link

## SMMF for Nonswitched SDLC Peripheral Devices

You can use SMMF to activate a peripheral device over a nonswitched SDLC peripheral link. Code the following definition statements and keywords to provide NCP with information about the physical unit to be activated.

PU	XMONLNK
----	---------

## SSCP Monitor Mode Function

XMONLNK on the PU definition statement specifies whether SMMF is to activate and monitor a nonswitched peripheral SDLC link.

### Sample Coding for SMMF to Activate a Nonswitched Peripheral Link

Figure 5-6 shows sample coding to define SMMF for a peripheral device attached to a nonswitched SDLC link.

```
P00321A PU .  
          .  
          .  
          XMONLNK=YES          SMMF activates the link to the device
```

Figure 5-6. Example: Defining SMMF for a Nonswitched Peripheral Link

## SMMF for Subarea Channel Links

Using SMMF, the subarea channel link activation function enables NCP to activate and deactivate subarea channel links the same way that SDLC subarea links are activated and deactivated. NCP can also use SMMF to activate channel links to adjacent type 5 physical unit stations.

Code the following definition statements and keywords to provide NCP with information about the subarea link to be activated and the action to be taken when an error condition occurs.

LINE	MONLINK
PU	ANS

MONLINK on the LINE definition statement specifies whether SMMF is to activate and monitor the channel link. Code MONLINK=CONTINUOUS or YES for channel links.

ANS on the PU definition statement indicates whether the device continues to operate if NCP enters automatic network shutdown (ANS). ANS=CONTINUE causes NCP to continue to service the link station when automatic network shutdown is initiated.

### Sample Coding for SMMF to Activate a Subarea Channel Link

Figure 5-7 on page 5-17 shows sample coding for SMMF to activate a subarea channel link.

```

CAGROUP  GROUP LNCTL=CA
*
CALINE   LINE  ADDRESS=0,
          MONLINK=YES           SMMF activates link
*
CAPU     PU    PUTYPE=5,
          ANS=CONTINUE,        Physical unit type
                                Continue to monitor when NCP is in ANS
          .
          .
          .

```

Figure 5-7. Example: SMMF Activating a Subarea Channel Link

### SMMF for ESCON Links

Before SMMF can activate an ESCON link, it must first activate the physical line. Code the following definition statement and keyword to enable SMMF to activate an ESCON physical line.

```

PU          XMONLNK

```

XMONLNK on the PU definition statement for the physical connection specifies whether SMMF is to activate and monitor an ESCON physical line. Code XMONLNK=YES when you define any ESCON physical line that is used to load and activate NCP.

Code the following definition statement and keyword to enable SMMF to activate an ESCON logical link once the physical line has been activated.

```

LINE          MONLINK
PU           ANS
            MONLINK

```

MONLINK on the LINE definition statement specifies whether SMMF is to activate an ESCON link. Code MONLINK=CONTINUOUS or MONLINK=YES. Code XMONLNK=YES on the corresponding definition of any ESCON physical line that is used to load and activate NCP. If you code XMONLNK=NO or MONLINK=NO, the NCP load and activation will fail.

See “Using MOSS Extended to Configure ESCON Links” on page 4-22 for a description of the MOSS-E IPL option and how it relates to the MONLINK and XMONLNK keywords. See *NCP and EP Reference* for more information about SMMF.

ANS on the PU definition statement indicates whether the device continues to operate if NCP enters automatic network shutdown (ANS). Code ANS=CONTINUE for channel-attached lines if PUTYPE=5.

MONLINK specifies whether SMMF is to activate the physical unit associated with the ESCON link. This allows more control of ESCON resources that are supported

## SSCP Monitor Mode Function

by an IBM 3745-41A or 3745-61A operating in *twin-in-dual* or *twin-in-backup* mode. See “Shared 3746 Model 900 Resources between Two NCPs” on page 3-7 for more information. Table 5-1 on page 5-18 shows the MONLINK value you can code on the PU definition statement depending on the MONLINK value coded on the LINE definition statement.

Table 5-1. MONLINK Values for ESCON Links

<b>If you code this on the LINE definition statement</b>	<b>Code this on the PU definition statement</b>
MONLINK=YES	MONLINK=YES
	MONLINK=NO
MONLINK=CONTINUOUS	MONLINK=YES
	MONLINK=NO
MONLINK=NO	MONLINK=NO

### Sample Coding for SMMF to Activate an ESCON Link

Figure 5-8 on page 5-19 shows sample coding for SMMF to activate and monitor an ESCON logical subarea channel link. NCP will continue to monitor the logical link even when the link is in automatic network shutdown. MONLINK on the PU defaults to YES because MONLINK=CONTINUOUS is specified on the LINE definition statement.



```

*****
*   ESCON PHYSICAL LINE 2240   *
*****
*
G31RSOC1 GROUP LNCTL=CA,           *
                MONLINK=NO,        *
                SPEED=144000000,    *
                SRT=(32768,32768),  *
                XMONLNK=YES         *
                Physical line activated by SMMF
*
A31S2240 LINE  ADDRESS=2240         ESCON physical line 2240
*
A31P2240 PU    ANS=CONTINUE,        *
                PUTYPE=1
*
*****
*   ESCON LOGICAL LINE 1 GROUP 1 (ESCON PHYSICAL CHANNEL 2240) *
*****
*
G31LSOC1 GROUP CASDL=0.0,          *
                DELAY=0.2,          *
                LNCTL=CA,           *
                MAXPU=16,           *
                PHYRSC=A31P2240,    *
                PUDR=YES,           *
                SPEED=144000000,    *
                SRT=(20000,20000),  *
                TIMEOUT=840.0,      *
                TRANSFR=200
*
A31S1L1 LINE  ADDRESS=NONE,         ESCON physical line 2240 *
                HOSTLINK=1,         *
                MONLINK=CONT        *
                Logical line activated by SMMF
*
A31S1P11 PU   ADDR=01,              Station 1, I/O device UNITADD=01*
                ANS=CONTINUE,        Device continues when in ANS *
                PUDR=NO,             *
                PUTYPE=5,            Subarea host node           *
                TGN=1

```

Figure 5-8. Example: SMMF Activating an ESCON Link

## Spare and Redefinable SDLC Lines

3745-attached SDLC peripheral lines can be generated as spare lines, as redefinable lines, or as neither. A spare line is not in use and cannot be activated. A redefinable line can be activated and used.

**Note:** If you do not use NTuneMON, NTuneNCP, NetView, and VTAM, you can never use the lines you generate as spare lines, and you cannot change redefinable lines to spare lines. Also, you cannot change the characteristics of your lines.

By generating spare and redefinable lines, you can use NTuneMON with NTuneNCP to enable and disable the activation of physical lines from your communication controller without regenerating and reloading NCP. When you code spare and redefinable lines, you define the characteristics of the physical line that will be added to or removed from your communication controller.

## Spare and Redefinable SDLC Lines

When you generate a spare line in NCP, you create a line address to which you can later add a physical line. When you attach the new physical line, you use NTuneMON with NTuneNCP to:

- Change its definition in NCP from a spare line to a redefinable line
- If needed, change certain characteristics about the line that were generated in NCP, such as the characteristics you define with the DUPLEX or CLOCKNG keywords
- Activate the line.

A spare or redefinable line is assigned at generation time to a specific physical line and cannot be changed to another physical line by using NTuneMON with NTuneNCP.

When you remove from your communication controller a physical line that was generated as a redefinable line in NCP or that was changed from a spare line to a redefinable line by using NTuneMON with NTuneNCP, you do not have to regenerate and reload NCP. Use NTuneMON with NTuneNCP to change it to a spare line.

See the chapter in the *NTuneMON User's Guide* about adding SDLC lines for information about:

- Using NTuneMON for spare and redefinable lines
- Which line characteristics you can change using NTuneMON.

Code the following keywords to generate 3745-attached SDLC peripheral lines as spare lines or redefinable lines.

LINE	TYPE
	USE

TYPE on the LINE definition statement defines whether the line will operate in network control mode (TYPE=NCP), emulation mode (TYPE=EP), or both (TYPE=PEP). Code TYPE=NCP.

USE defines whether the line is initially a spare line (USE=SPARE), a redefinable line (USE=REDEF), or neither (USE=NCP). SPARE and REDEF are valid only if the TYPE keyword is coded as TYPE=NCP.

### Notes:

1. Code only one spare or redefinable line per GROUP definition statement.
2. You can change a spare line to a redefinable line, or a redefinable line to a spare line, only if you include NTuneNCP in your NCP generation. If NTuneNCP is not included, you will not be able to change spare lines to redefinable lines, and, consequently, will not be able to activate the lines.
3. A line defined as USE=NCP cannot be changed to a spare or redefinable line.

See the *NTuneMON User's Guide* for more information about spare lines and redefinable lines.

## Converting Existing SDLC Resources to 3746 Model 900 SDLC Resources

This section describes how to update your generation definition so that you can move the attachments for existing SDLC lines from the IBM 3745 to the 3746 Model 900.

A line group cannot contain a mixture of SDLC lines attached directly to the IBM 3745 and to the 3746 Model 900. If you want to move some of the lines in an existing SDLC group to the 3746 Model 900, you need to create a separate group for those lines.

Figure 5-9 shows the definition of an SDLC line attached directly to the IBM 3745.

```

*****
*          SDLC LEASED LINE DEFINITIONS          *
*****
GA03SDL1 GROUP LNCTL=SDLC,          SDLC line control          *
                TYPE=NCP            Operates in network control mode
*
L00321  LINE  ADDRESS=1024,          Relative line number          1 *
                CLOCKNG=EXT,        Modem provides clocking
                DUPLEX=FULL         Duplex line
*
P00321A PU  .
                .
                .
    
```

Figure 5-9. Example: Converting an SDLC Line to a 3746 Model 900 SDLC Line (Before)

The following steps describe how to convert the definition shown in Figure 5-9 to a 3746 Model 900 SDLC line definition.

- 1** Change the value of ADDRESS on the LINE definition statement to a 3746 Model 900 line number. Refer to *NCP, SSP, and EP Resource Definition Reference* for a list of 3746 Model 900 line numbers.
- 2** Add the SPEED keyword to the LINE definition statement. It is required for 3746 Model 900 lines.

Figure 5-10 shows the SDLC line definition after the conversion.

```

*****
* 3746 MODEL 900-ATTACHED SDLC LEASED LINE DEFINITIONS *
*****
GA03SDL1 GROUP LNCTL=SDLC,          SDLC line control          *
                TYPE=NCP            Operates in network control mode
*
L00321  LINE  ADDRESS=2112,          3746 Model 900 line address  1 *
                CLOCKNG=EXT,        Modem provides clocking
                DUPLEX=FULL,        Duplex line
                SPEED=1474560       High speed line          2 *
*
P00321A PU  .
                .
                .
    
```

Figure 5-10. Example: Converting an SDLC Line to a 3746 Model 900 SDLC Line (After)

---

## Modems

This section describes the definition statements and keywords that define the operational and physical characteristics of all modems, including channelized modems, attached to NCP. If you are using the LPDA function with your system's modems, see "Link Problem Determination Aid" on page 23-4 for additional information.

Code the following definition statement and keywords to provide NCP with information about the data transmission rate and the operating characteristics of the modem.

LINE	DATRATE NEWSYNC NRZI SPDSEL SPEED
------	---

DATRATE specifies a high or low data rate for a dual rate modem.

NEWSYNC on the LINE definition statement determines whether the communication controller supplies the new-sync signal to the modem attached to the controller for the SDLC or BSC link. Code NEWSYNC=YES to reduce the line-turnaround time expended each time the direction of transmission on the link is reversed. NCP can supply the new-sync signal when the following conditions are true:

- The modem can respond to the new-sync signal.
- The link is a duplex link.
- More than one secondary modem is attached to the link.

If only one multipoint or point-to-point link-attached station is connected to the link, code NEWSYNC=NO. If the controller sends the new-sync signal to such a station, unpredictable results may occur when gathering link statistics. Consult the supplier or installer of your modem for further information about the new-sync signal.

NRZI indicates whether the data terminal equipment at each end of the SDLC link operates in non-return-to-zero change-on-ones (NRZI) mode or in non-return-to-zero (NRZ) mode. NCP transmits data over an SDLC link in either NRZI or NRZ format depending on the type of modems serving the line.

The modems at each end of the link must remain synchronized with each other for the duration of message transmission. To remain synchronized, modems sensitive to transitionless bit streams require bit transitions (0 to 1 or 1 to 0) at intervals in the data stream. In NRZI mode, the data terminal equipment at each end of the line introduces the appropriate transitions into the data stream. In NRZI mode, sequences of zeros (000000...) are converted to alternating ones and zeros (101010...), thus satisfying those modems sensitive to transitionless bit streams.

Certain other modems, however, are sensitive to just this alternating one-zero pattern, rather than to transitionless bit streams. They lose synchronism if subjected to one-zero patterns of sufficient length. If external (modem) clocking is used for the link and the modems are sensitive to repeated binary one-zero pat-

terns, NRZ mode is required. Consult the supplier or installer of your modems to determine whether the modems are sensitive to repeated one-zero bit patterns.

**Note:** All devices on the same SDLC link must use the same encoding scheme. Mixing modes on the same SDLC link prevents communication between the devices on the link.

SPDSEL specifies whether the access method can change the data rate you code for DATRATE.

SPEED defines the line speed. For valid SPEED values, see the manuals for your modem.

### Sample Modem Definition

Figure 5-11 shows the physical relationship of the modem to NCP.



Figure 5-11. Modem Configuration

Figure 5-12 shows sample coding to define the modem connection shown in Figure 5-11. When the SPDSEL default is used, the data rate for the modem cannot be changed by the access method.

```

L04068  LINE  ADDRESS=(068,FULL), Relative line number
          NEWSYNC=NO,      No new-sync signal sent to modem
          NRZI=YES,        DTE operates in NRZI mode (IBM modem)
          SPEED=56000      Modem speed in bits per second

*
P04068A PU  .
            .
            .
  
```

Figure 5-12. Example: Defining a Modem

## Channelized Modems

Channelized modems, which are IBM modems with data multiplexing capability, support multiple lines through one local and remote modem pair. All lines or channels using this pair of modems share a common physical interface, called the channelized link, that connects the two modems. If you are using the LPDA function with channelized modems, see “Link Problem Determination Aid” on page 23-4 for additional information.

Code the following definition statement and keywords to provide NCP with information about the channelized modem connection.

```

LINE          CHNLZ
              CORNUM
  
```

CHNLZ specifies whether a line is attached to a channelized modem.

CORNUM defines a 2-byte correlation number for all the lines attached to a particular channelized modem. A maximum of four lines can have the same correlation number in your NCP generation. Each data multiplex modem must have a unique CORNUM. A maximum of four links can have the same CORNUM. You cannot code lines with the same CORNUM as LPDA-1 and LPDA-2.

**Note:** Lines with different protocols (such as SDLC, BSC, or start-stop) can share the same channelized modem. For start-stop lines, LPDA-2 is not supported. However, if you specify LPDATS=NO, you can code the CHNLZ and CORNUM keywords.

**3746 Model 900 SDLC Lines:** If you use a channelized modem, all lines must be attached to either the 3746 Model 900 or the IBM 3745. You may not use a combination of 3746 Model 900 lines and lines attached to the IBM 3745.

### Sample Definition of a Channelized Modem

Figure 5-13 shows a channelized modem connection.

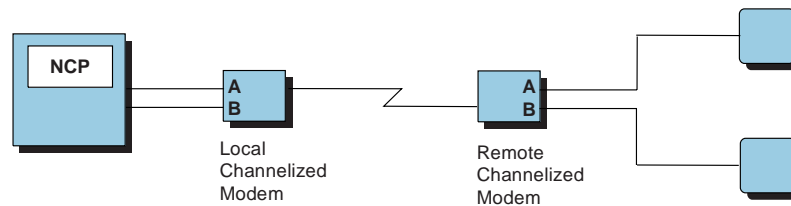

Figure 5-13. Channelized Modem Configuration

Figure 5-14 shows sample coding to define the channelized modem shown in Figure 5-13.

```

.
L06132  LINE  ADDRESS=132,      Relative line number
          CHNLZ=YES,      Modem with data multiplexer feature
          CORNUM=1        Line correlation number
          CHANLA=YES      Attached to channel A
          PORT=A          Attached to port B

*
P06132A PU  .
           .
           .

*
L06133  LINE  ADDRESS=133,      Relative line number
          CHNLZ=YES,      Modem with data multiplexer feature
          CORNUM=1        Line correlation number
          CHANLA=NO      Not attached to channel A
          PORT=B          Attached to port B

*
P06133A PU  .
           .
           .
    
```

Figure 5-14. Example: Defining a Channelized Modem

## Switched Network Backup

You can define an alternate link for NCP to use when it is unable to communicate with a device over a nonswitched point-to-point or multipoint link. Code the following definition statements and keywords to provide NCP with information about generating the backup option and an alternate dial set.

SYSCNTRL	OPTIONS
LINE	DIALALT

OPTIONS on the SYSCNTRL definition statement enables you to specify the BACKUP option, which adds the switched network backup dynamic control facility to the generated NCP.

DIALALT on the LINE definition statement identifies the alternate dial set your NCP uses when it selects a backup BSC or start-stop link. Upon request from the access method, NCP calls the device over a link named in the dial set you specify for DIALALT. The links in the dial set must have the same characteristics as the nonswitched link.

### Sample Definition of Switched Network Backup

Figure 5-15 shows an example of switched network backup.

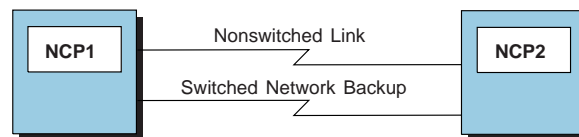

Figure 5-15. Switched Network Backup

Figure 5-16 shows sample coding to define the switched network backup shown in Figure 5-15.

```

          SYSCNTRL OPTIONS=(BACKUP, Switched network backup
          .
          .
          .
*****
*          DIALSET FOR ALTERNATE DIAL INTO NCP2          *
*****
*
SWITBS00 DIALSET LINES=L001002,      Lines using this dialset
          QLIMIT=0                    Don't allow multiple callouts
*
  
```

Figure 5-16 (Part 1 of 2). Example: Defining Switched Network Backup

## Devices Attached to NCP

```
*****
*           ALTERNATE SWITCHED BSC LINK INTO NCP2 (DO NOT ACTIVATE) *
*****
*
GA01BS2A GROUP DIAL=YES,           Switched lines
                LNCTL=BSC,         BSC line control
                TYPE=NCP           Lines operate in network control mode
*
L001002 LINE ADDRESS=(002,HALF), Relative line number
                AUTO=030,         Relative line number of auto call unit
                CALL=INOUT,       Incoming and outgoing calls
                CLOCKNG=EXT,      Modem provides clocking
                DIALSET=SWITBS00, Dialset for this line
                DUPLEX=FULL       Duplex line
*
P001002A PU .
          .
          .
*
*****
*           NONSWITCHED BSC LINK TO NCP2 *
*****
*
GA01BS2 GROUP LNCTL=BSC,         BSC line control
                TYPE=NCP           Lines operate in network control mode
*
L001003 LINE ADDRESS=(003,HALF), Relative line number
                CLOCKNG=EXT,      Modem provides clocking
                DIALALT=SWITBS00, Alternate dialset if this link fails
                DUPLEX=FULL       Duplex line
*
P001003A PU .
          .
          .
```

Figure 5-16 (Part 2 of 2). Example: Defining Switched Network Backup

---

## Devices Attached to NCP

The following sections describe the definition statements and keywords needed to define the characteristics of link-attached devices to NCP.

### BSC or Start-Stop Devices on Nonswitched Links

You can establish communication over a nonswitched link. Code the following definition statements and keywords to provide NCP with operational information about the BSC or start-stop device and how to improve data transmission and recover from errors.



LINE	CRRATE LINESIZ
CLUSTER	CUTYPE FEATURE LGRAPHS
TERMINAL	ATTN CONV CRDLAY DIRECTN FANOUT FEATURE LGRAPHS TERM VPRINT
COMP	ATTN CONV LGRAPHS

## LINE

CRRATE on the LINE definition statement specifies the number of print positions the carriage returns for each idle character NCP sends to any printers attached to a start-stop link.

LINESIZ designates the length of the print line for any printers attached to the start-stop link. If the printers attached to the link have differing line lengths, LINESIZ must be the maximum length used by any printer on the link.

**Note:** The value of LINESIZ divided by the value of CRRATE equals the number of idle characters sent by NCP. Select the values for LINESIZ and CRRATE to suit the types of devices attached to the link. Too few idle characters following a carriage return character or a tab character do not provide sufficient time for the mechanism to reach the next printing position, resulting in random printing of text characters on the print line. Too many characters cause excessive delay in the resumption of printing, resulting in wasted time on the link.

## CLUSTER

CUTYPE on the CLUSTER definition statement specifies the model number of the cluster controller used by the clustered station. A clustered BSC station is a collection of devices that make up an IBM 3270 Information Display System or an IBM 2972 General Banking Terminal System. Define the individual devices that are attached to the cluster controller by coding a TERMINAL definition statement for each device.

FEATURE on the CLUSTER definition statement determines how NCP identifies a BSC device that responds to a poll. If you code FEATURE=GPLKUP, NCP searches a table that contains only addresses of devices in use on the cluster. Otherwise, a TERMINAL definition statement must be generated for each of the controller device addresses, even if there is no corresponding device.

## Devices Attached to NCP

FEATURE also specifies how NCP is to handle data received from an undefined terminal in response to a BSC general poll. If you specify FEATURE=NOIGNORE, the data will be discarded and the general poll will be terminated. If you specify FEATURE=IGNORE, the data will be discarded and the general poll will continue.

LGRAPHS on the CLUSTER, TERMINAL, or COMP definition statement specifies whether NCP accepts or rejects leading graphics sent by the clustered BSC control unit for both read and write operations.

## TERMINAL

All TERMINAL definition statements defining BSC devices attached to the same modem must appear consecutively.

ATTN on the TERMINAL definition statement specifies to NCP whether the attention signal of a BSC or start-stop device is enabled or disabled. If the signal is enabled, an attention signal from the device causes NCP to cease transmission and to notify the access method. If the signal is disabled, NCP ignores the signal. Code ATTN on the TERMINAL and COMP definition statements if you define an IBM 1050 Data Communication System terminal, an IBM 2741 Communication Terminal, a TWX terminal, or a WTTY terminal.

CONV on the TERMINAL and COMP definition statements indicates whether you want the BSC or start-stop device to accept message data from NCP instead of a positive response to a block of text the device has sent. This is called conversational response and occurs only if NCP has data to send. Otherwise, NCP sends the usual positive response. Transmitting message data instead of a positive response eliminates the turnaround time incurred when NCP sends a positive response character followed by an addressing character to the device, then waits for a response to the addressing character before sending message data to the device.

CRDLAY enables NCP to delay executing a write operation after receiving a carriage return from a start-stop device. There is no delay if there is a READ command queued in NCP as the next operation for the device. Use CRDLAY if you define an IBM 1050 Data Communication System terminal; an IBM 2740 Communication Terminal, Model 1; an IBM 2741 Communication Terminal; a TWX terminal; or an MTA terminal.

DIRECTN specifies whether the BSC or start-stop device is to send data to NCP, receive data from NCP, or both. If you specify that the device can send only, NCP rejects any requests from the access method to transmit data to the device; if you specify that the device can receive only, NCP rejects any requests from the access method to accept data from the device.

FANOUT appears on the first TERMINAL definition statement in the sequence to indicate the name of the last TERMINAL definition statement in the sequence. Code FANOUT if you attach more than one BSC device to the same modem.

FEATURE on the TERMINAL definition statement specifies the machine features with which certain BSC or start-stop devices can be equipped. The following features can be installed on the devices listed:

- **Transmit Interrupt.** *IBM 1050 Data Communication System terminal, IBM 2741 Communication Terminal, IBM 3767 Communication Terminal in 2741 mode, TWX terminal, WTTY terminal, MTA terminal, 83B3 Selective Calling*

*Station, and WU Plan 115A Outstation.* If the device has this feature, NCP can interrupt a transmission from the device by sending a break signal.

- **Attention Signal.** *IBM 1050 Data Communication System terminal, IBM 2741 Communication Terminal, IBM 3767 Communication Terminal in 2741 mode, TWX terminal, WTTY terminal, MTA terminal, 83B3 Selective Calling Station, and WU Plan 115A Outstation.* If the device has this feature, it can interrupt NCP while it is sending data to the device. This is true for an IBM 1050 device only if it is equipped with the receive interrupt feature. This is true for an IBM 2741 device or an IBM 3767 device (in 2741 mode) only if it is equipped with the interrupt feature.
- **Accelerated Carrier Return.** *IBM 1050 Data Communication System terminal.* If the device has this feature, NCP sends fewer idle characters than it would if the device did not have this feature. This saves a small amount of transmission time whenever the new line (NL) character occurs in message data.
- **Record Checking.** *IBM 2740 Communication Terminal.* If the device has this feature, it affects the command sequence NCP uses to communicate with the device.
- **Station Control.** *IBM 2740 Communication Terminal, Model 1.* If the IBM 2740 device has this feature, it affects the command sequence NCP uses to communicate with the device.
- **Transmit Control.** *IBM 2740 Communication Terminal, Model 1.* If the IBM 2740 device has this feature, it affects the command sequence NCP uses to communicate with the device.
- **Timeout Suppression.** *IBM 1050 Data Communication System terminal.*

TERM defines the type of BSC or start-stop device. If you define a call-in logical-connection station representing more than one type of BSC device, TERM specifies any one of these types. A logical-connection station is a set of control blocks within NCP representing all devices that send calls to NCP over a switched link.

VPRINT specifies whether the BSC or start-stop device is to be treated as a virtual printer because it requires special printer processing, even though it is not a true printer. The device must be defined as a graphics device.

### Sample Definition of BSC or Start-Stop Devices on Nonswitched Links

Figure 5-17 shows how BSC or start-stop devices are attached to nonswitched links.

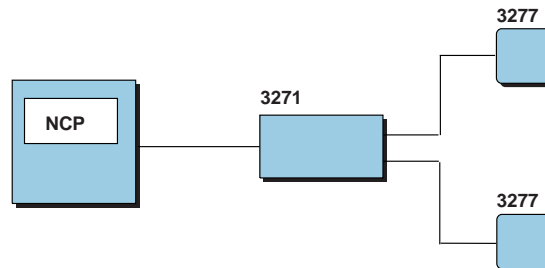

Figure 5-17. BSC or Start-Stop Devices

## Devices Attached to NCP

Figure 5-18 shows how to define the devices shown in Figure 5-17 on page 5-29.

CA03000	CLUSTER CUTYPE=3271	IBM model 3271 control unit
*		
TA03000A	TERMINAL CONV=YES, DIRECTN=INOUT, TERM=3277	NCP sends message block as a response Sends and receives text Type of device to communicate with
*		
TA03000B	TERMINAL CONV=YES, TERM=3277	NCP sends message block as a response Type of device to communicate with

Figure 5-18. Example: Defining BSC or Start-Stop Devices on Nonswitched Links

## BSC or TWX Devices Attached to Switched Links

You can define BSC or TWX devices on switched links. Code the following definition statements and keywords to provide NCP with information about the physical connection, how to define and manage these devices, and how data is to be transmitted. Code these definition statements and keywords in addition to those found in “BSC or Start-Stop Devices on Nonswitched Links” on page 5-26.

BUILD	CUID
IDLIST	IDSEQ MAXLEN NOMATCH
TERMINAL	CTERM CUIDLEN DIALNO DIALSET IDSEQ

### BUILD

CUID on the BUILD definition statement defines the reply character sequence NCP sends to BSC or TWX devices attached to switched links in response to a valid device identification sequence. The reply characters are sent to each device for which you code CUIDLEN on the TERMINAL or COMP definition statement. The initial contact between NCP and a device is as follows:

1. The BSC device calls NCP by sending the identification sequence over a switched link.
2. When NCP receives the identification sequence, it either checks it against an internal list of valid IDs or sends it to the access method to check against its list of valid IDs, depending on the IDSEQ value coded on the TERMINAL definition statement.
3. If NCP does not recognize the sequence, it either breaks the link connection or maintains the connection while it forwards the unrecognized ID to the access method for checking. The action to be taken depends on the NOMATCH value on the IDLIST definition statement.

4. If the access method finds the ID valid, it signals NCP to continue message transmission.
5. If the access method finds the ID invalid, it signals NCP to break the transmission.
6. If the ID is validated, NCP sends the reply character sequence coded on the CUID keyword.

## IDLIST

IDSEQ on the IDLIST definition statement defines the identification sequence used by each BSC or TWX device that can call NCP. It can also identify the TERMINAL definition statement that defines the physical device associated with the identification sequence. Code the EBCDIC ID in hexadecimal format.

MAXLEN specifies the maximum size of the list of identification sequences you specify for IDSEQ. Code MAXLEN only if the access method uses the dynamic control facility to add entries to the list or to increase the size of one or more existing entries in the list. MAXLEN identifies the number of bytes in the list, not the number of entries in the list, for a maximum of 256 bytes. It includes the number of bytes in all list entries and the control field that precedes the list.

NOMATCH determines the action NCP takes if it receives an invalid identification sequence from a calling BSC or TWX device, or if it receives no identification sequence. The NCP response to the undefined sequence can be either to return the invalid sequence to the access method or to break the link connection.

**Note:** Code IDSEQ, MAXLEN, and NOMATCH on the IDLIST definition statement only for TCAM.

## TERMINAL

CTERM on the TERMINAL definition statement identifies a terminal that calls the controller over a switched line. Code CTERM if the BSC or TWX device can only send calls, or can both send and receive calls; omit CTERM if the device can only receive calls. Code CTERM=YES to define a logical-connection station. Code CTERM=YES on only one TERMINAL definition statement following the LINE definition statement that defines a switched line with attached call-in devices. If you code CTERM=YES on this TERMINAL definition statement, do not use the name of this TERMINAL definition statement as the keyword value in any other definition statement.

CUIDLEN defines the length of the CUID sequence that NCP sends to the BSC or TWX device.

DIALNO specifies the telephone number that NCP uses to call the BSC or TWX device. The DIALNO value can be changed later, during the running of the program, by means of the dynamic control facility. See *NCP, SSP, and EP Resource Definition Reference* for specific information about NCP dialing procedures.

DIALSET identifies the DIALSET definition statement that defines the set of links used whenever NCP gets a callout request for this device. Code DIALSET if NCP calls a BSC or TWX device. NCP attempts to call the device over one of the links in the designated dial set.

IDSEQ specifies whether a BSC or TWX device sends an identification sequence when it calls or is called by NCP and, if so, how NCP is to react to the sequence.

### Sample Definition of BSC or Start-Stop Devices on Switched Links

Figure 5-19 shows how BSC and start-stop devices are attached to switched links.

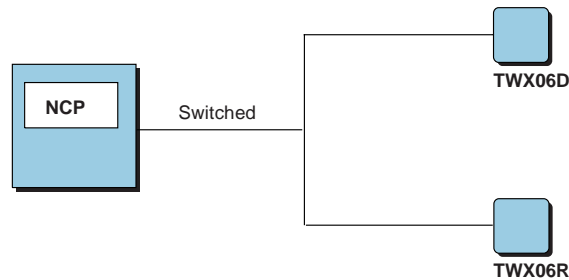

Figure 5-19. BSC or Start-Stop Devices Attached to Switched Telecommunication Links

Figure 5-20 shows how to define the devices shown in Figure 5-19.

```

*****
*           DIALSET FOR CALLOUTS TO TWX DEVICES           *
*****
*
SWITWX06 DIALSET .
.
.
*
*****
*           SWITCHED START-STOP LINK TO TWX DEVICES       *
*****
.
.
.
TWX06D  TERMINAL ATTN=ENABLED,      Enable attention signal
        BHSET=HEDIT16,             Specify name of block handler set
        CRDLAY=YES,                Delay processing of write operation
        CTERM=YES,                 Devices defined to call controller
        DIALSET=SWITWX06,          Reference to dialset definition
        TERM=TWX,                  Device type specified
        FEATURE=(NOBREAK,ATTN)     Break signal disallowed,
                                   attention signal allowed
*
TWX06R  TERMINAL ATTN=ENABLED,      Enable attention signal
        BHSET=HEDIT16,             Specify name of block handler set
        CRDLAY=YES,                Delay processing of write operation
        CTERM=NO,                  No devices defined to call controller
        DIALNO=CRN47583,           EBCDIC dial digits
        DIALSET=SWITWX06,          Reference to dialset definition
        TERM=TWX,                  Device type specified
        FEATURE=(NOBREAK,ATTN)     Break signal disallowed,
                                   attention signal allowed

```

Figure 5-20. Example: Defining BSC and Start-Stop Devices on Switched Links

## BSC Devices and VTAM

The following keywords are processed when VTAM processes the NCP NEWDEFN file. Use these keywords on the LINE, CLUSTER, and TERMINAL definition statements if the clustered BSC 3270 station can be owned by VTAM. See *VTAM Resource Definition Reference* for a description of these keywords.

LINE	PU SECTNET
CLUSTER	DISCNT VPACING
TERMINAL	ASLENT ASLTAB DLOGMOD FEATUR2 ISTATUS LOGAPPL LOGTAB MDLENT MDLTAB MODETAB USSTAB

## SDLC Devices on Nonswitched Links

Code the following definition statements and keywords to define an SDLC device attached to a nonswitched link.

PU	ADDR BNNSUP PUTYPE
LU	LOCADDR

Define an SDLC device to NCP by providing NCP with the physical and logical address of the device and the type of physical unit.

ADDR on the PU definition statement defines the physical address of the device. Code the hexadecimal representation of the 8-bit address of the device.

BNNSUP specifies that the SDLC device is a type 1 physical unit IBM 3270 Information Display System attached to a nonswitched SDLC link.

PUTYPE defines the physical unit type of the SDLC device. Refer to the documentation for your particular device if you are not sure of the device type. If you define an NCP that is connected to another NCP, PUTYPE specifies that there is a link station to an adjacent communication controller. Read Chapter 12 and in particular "Subarea Links and Link Stations" on page 12-1 for information on link stations.

## Devices Attached to NCP

LOCADDR on the LU definition statement specifies the decimal address of the logical unit associated with the SDLC device; code LOCADDR=0 to define an independent logical unit. See Chapter 8 for more information about independent logical units.

### Sample Definition of SDLC Devices on Nonswitched Links

Figure 5-21 shows how SDLC devices can be attached to nonswitched links.



Figure 5-21. SDLC Devices Attached to Nonswitched Telecommunication Links

Figure 5-22 shows how to define the devices shown in Figure 5-21.

P00321A	PU	ADDR=C1, BNNSUP=3270, MAXDATA=256, PUTYPE=1	Hexadecimal physical unit address IBM 3270 device 256 bytes in a PIU Physical unit type
*			
L003021A	LU	LOCADDR=0	Independent logical unit
*			
L003021B	LU	LOCADDR=1	Local address of logical unit

Figure 5-22. Example: Defining SDLC Devices Attached to Nonswitched Links

## SDLC Devices on Switched Links

Code the following definition statements and keywords to provide NCP with logical unit control block information and with information about the device.

LUDRPOOL	NUMILU NUMTYP1 NUMTYP2
PU	PUTYPE MAXLU

NUMILU on the LUDRPOOL definition statement defines the number of independent logical units eligible for dynamic reconfiguration. NUMTYP1 defines the number of dependent logical units eligible for dynamic reconfiguration under type 1 physical units. NUMTYP2 defines the number of dependent logical units eligible for dynamic reconfiguration under type 2 or type 2.1 physical units. The values of NUMILU, NUMTYP1, and NUMTYP2 are used to create empty control blocks in logical unit control block pools. The control blocks get used when new logical units are added to SDLC devices attached to NCP.



**Notes:**

1. The NUMILU, NUMTYP1, and NUMTYP2 keywords each create control blocks in several control block pools. Some of these control blocks are in the same pools, some are not.

For the LUB control block pool, for example, the values of NUMILU, NUMTYP1, and NUMTYP2 are added together to form a single pool of resources. A result of this is that you may be able to dynamically add more logical units for type 2 physical units than what you defined on the NUMTYP2 keyword. This is because the LUBs and the other control blocks created for NUMTYP2 are also created for NUMTYP1. But, you will not be able to dynamically add more logical units for type 1 physical units than what you defined on the NUMTYP1 keyword (see note 2 for an exception). This is because the LTX control block pool is created only for the NUMTYP1 keyword. See the chapter on control block management in the *NCP and EP Reference* for detailed information on the control blocks created from the NUMILU, NUMTYP1, and NUMTYP2 keywords.

2. You can cause NCP to dynamically create additional logical unit resources to supplement those defined by NUMILU, NUMTYP1, and NUMTYP2 when needed. See “Dynamically Created Control Blocks” on page 2-10 for more information.

PUTYPE on the PU definition statement defines the physical unit type of the SDLC device. Refer to the documentation for your particular device if you are not sure of your physical unit device type. If you are defining an NCP that is connected to another NCP, PUTYPE specifies that there is a link station to the adjacent communication controller. Read Chapter 12 and in particular “Subarea Links and Link Stations” on page 12-1 for information on link stations.

MAXLU specifies the maximum number of logical units to be associated with an SDLC device. MAXLU should represent the actual number of logical units associated with the SDLC device plus the number of logical units you expect to add to the SDLC device using dynamic reconfiguration. MAXLU is not supported if you code VIRTUAL=NO on the GROUP definition statement.

**Sample Definition of SDLC Devices on Switched Links**

Figure 5-23 shows how SDLC devices are attached to switched links.

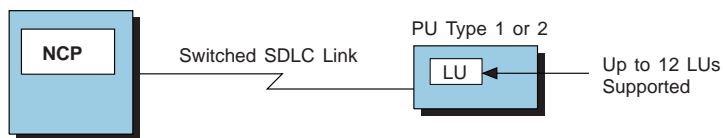

Figure 5-23. SDLC Devices Attached to Switched Telecommunication Links

Figure 5-24 on page 5-36 shows how to define the SDLC devices shown in Figure 5-23. The SDLC device definition falls under a line group that does not support programmed resources (VIRTUAL=NO); therefore, MAXLU is not required on the PU definition statement.

## Devices Attached to NCP

```
          LUDRPOOL NUMTYP1=12,      12 LUs for type 1 PUs
          NUMTYP2=12                12 LUs for type 2 PUs
*
*                                  Switched SDLC link to SDLC device
*                                  definitions
P00324A PU  PUTYPE=(1,2)           Type 1 and 2 PUs supported
```

Figure 5-24. Example: Defining SDLC Devices on Switched Telecommunication Links

## SDLC Devices and VTAM

The following keywords are processed for SDLC devices when VTAM processes the NCP NEWDEFN file. Use these keywords on the LUPOOL, PU, and LU definition statements if the SDLC device can be owned by VTAM. See *VTAM Resource Definition Reference* for a description of these keywords.

LUPOOL	OWNER
PU	DISCNT DLOGMOD ENCR FEATUR2 INNPORT ISTATUS LOGAPPL LOGTAB MODETAB SPAN SSCPFM TERM USSTAB VPACING
LU	ASLENT ASLTAB DLOGMOD ENCR FEATUR2 ISTATUS LOGAPPL LOGTAB MDLENT MDLTAB MODETAB SPAN SSCPFM TERM USSTAB VPACING

---

## Maximum Number of Sessions to Maintain

NCP is able to maintain multiple concurrent sessions over a multipoint BSC or start-stop line. Code the following definition statement and keyword to provide NCP with information about the number of concurrent sessions.

LINE	SESSION
------	---------

SESSION on the LINE definition statement defines the number of concurrent sessions you want NCP to maintain on a nonswitched multipoint BSC or start-stop link. NCP not only limits the number of sessions to the number you code, but also tries to maintain that many sessions to make maximum use of the link. The number of sessions will be less than the number you code whenever NCP has requests for fewer devices, or whenever fewer devices are ready to communicate with the access method.

**Note:** SESSION does not limit the number of sessions on the link if clustered BSC stations are attached and the cluster controller uses general polling to solicit input from its attached devices. NCP cannot control the number of devices that respond to a general poll by the cluster controller, and a separate session is established with each device that responds. However, for clustered BSC IBM 3270 Information Display System stations, be sure the session limit equals the sum of the number of cluster controllers and the number of devices attached to the link.

---

## Polling and Addressing

NCP uses device polling to survey attached devices in a user-defined priority to see if they have data to transmit. Polling characters must be sent and buffers allocated for the PIUs transmitted by attached devices.

Code the following definition statements and keywords to provide NCP with information about these polling and addressing specifications.

## Polling and Addressing

GROUP	RNRLIMIT
LINE	AVGPB HDXSP PAUSE POLIMIT POLLED
SERVICE	ORDER
CLUSTER	GPOLL
TERMINAL	ADDR POLL SESSREQ
COMP	ADDR POLL
PU	AVGPB

Define polling and addressing by providing NCP with information about how to poll and address various devices, the physical connections, and how to improve performance.

### GROUP

RNRLIMIT on the GROUP definition statement specifies how long a given station can reject data before NCP identifies the station as inoperative. For example, a station is considered inoperative if it responds with a receive-not-ready (RNR) command to every poll sent by NCP during the interval defined. RNRLIMIT is not valid if you code LEVEL2 or LNCTL=USER on the GROUP definition statement.

### LINE

AVGPB on the LINE definition statement controls the use of buffers when NCP buffer space is limited and it controls the number of buffers allocated at one time. Code AVGPB if the link is a nonswitched multipoint link with attached BSC or start-stop devices. You can also code AVGPB on the PU definition statement if SDLC devices are defined.

NCP maintains a count of the number of buffers that are likely to be required to complete operations in progress. Before a device is polled, NCP requests additional buffers. When the requested buffers are filled, NCP makes a new request. If the sum of this count and the number of buffers actually allocated becomes too large, NCP limits the start of new operations and queues new requests. NCP stops polling and sends receive-not-ready (RNR) commands as requests fail.

AVGPB determines the size of the request to add buffers to the count. If NCP makes the request because the last buffer request is exhausted, the size of the request represents the number of buffers required to hold the number of bytes defined for AVGPB. If NCP requests the buffers *before* a poll, the size represents the number of buffers used to hold the PIUs received in response to the last poll, as long as that number falls between one and the number of buffers required to hold the number of bytes defined by AVGPB. If NCP receives no data, it uses one buffer. If NCP receives more bytes than you defined on the AVGPB keyword, it

uses the number of buffers required to hold the number of bytes defined by AVGPB.

The size of a request also affects the number of buffers allocated to the device at one time. If the size is smaller than the value coded for TRANSFR on the LINE or BUILD definition statement, all of the buffers are allocated at one time. If buffer space is not a limited resource, the performance of NCP usually improves by allocating more buffers at one time.

The size of a request has two significant effects on the performance of NCP:

- The size of the request controls the allocation of buffers when unused NCP buffer space is limited. NCP performance can improve if the AVGPB value is equal to the size of the largest PIUs that NCP receives from a device.
- The size of the request controls how much NCP buffer space is allocated to a device at one time. The allocation is determined by the value of AVGPB unless this value is greater than the space occupied by the number of buffers coded for TRANSFR on the LINE or BUILD definition statement. If this device is connected to NCP by a high-speed subarea link, and buffer space is not a limiting resource to NCP, NCP performs better if the value for AVGPB is as large as the space held by the number of buffers coded on TRANSFR.

**3746 Model 900 SDLC Lines:** The 3746 Model 900 performs NCP data link control functions, including polling. As a result, AVGPB is ignored for 3746 Model 900 SDLC lines.

HDXSP specifies half-duplex transmission mode. Code HDXSP=YES to cause the SDLC link to transfer data in half-duplex mode when more than one device is attached. Half-duplex transmission mode permits NCP to send data to a device as soon as possible instead of in the priority determined by the service order table.

PAUSE specifies the delay in seconds between successive polling cycles. If a pause occurs when activity on a link is relatively low, it can reduce the amount of processing time used for unproductive polling. A large number of active entries in the SOT increases the likelihood that polling cycles will proceed continuously without intervening pauses.

### Notes:

1. For BSC and start-stop links, code PAUSE only if the devices attached to the link must be polled and addressed. PAUSE specifies the delay between successive polling cycles when no sessions currently exist. If you do not code PAUSE, there is no delay between successive cycles. When at least one new session is established, the pause is disabled rather than cause a delay in session servicing.
2. For SDLC links, PAUSE specifies the average duration of the polling cycle. The polling cycle extends from the moment NCP examines the first entry in the SOT to the moment polling begins for the same entry in the next cycle. It includes time for polling, reading from, and writing to the devices on the link. If the time expended in a complete polling cycle (servicing all active entries in the SOT) equals or exceeds the PAUSE value, the next polling cycle begins immediately. If the time expended in a complete polling cycle is less than the PAUSE value, the beginning of the next polling cycle is delayed until the PAUSE time has elapsed. During a pause, the link is in poll-wait state; any

## Polling and Addressing

outgoing data ready for transmission to the SDLC devices on the link is sent during this pause.

The REPLYTO value in the primary NCP should be longer than the PAUSE value in the secondary NCP for subarea links. For large subarea configurations, the PAUSE value for the secondary state should be at least 0.5 seconds.

POLIMIT specifies the number of consecutive negative responses to polling that NCP accepts, and the action NCP takes if this number is reached. Code POLIMIT if the link is a nonswitched multipoint link. NCP can take the following actions:

- Maintain the logical connection, notify the access method that the negative response limit has been reached, and wait for another request from the access method before performing any further action on the link.
- Break the logical connection, notify the access method that it has done so, and terminate the current read request.
- Break the logical connection, notify the access method that it has done so, and queue the current read request onto the beginning of the device queue.

POLLED specifies whether BSC or start-stop devices attached to a link are to be polled and addressed. Code ADDR and POLL on the TERMINAL definition statement to define unique polling and addressing characters or sequences for each device. To receive data from a particular device, NCP sends it the polling character you assign to the device. When the device receives this character, it unlocks its keyboard to permit the operator to enter data or activate an input component. Similarly, to send data to the device, NCP sends it the addressing character you assign to the device. This signals the device to be ready to receive data from NCP.

If a device has more than one input component, such as a card reader or tape reader, as well as a keyboard, you can specify unique polling characters or sequences for each component by using POLL on the COMP definition statement. This lets NCP solicit data from individual components. Likewise, if the device has more than one output component, such as a display unit, a card or tape punch, and a printer, you can specify a unique addressing character or sequence for each component by using ADDR on the COMP definition statement.

**Note:** A device with multiple I/O components requires only one TERMINAL definition statement if the device has common polling and addressing capability. For example, an IBM 1050 Data Communication System device uses 0 for the common polling character and 9 for the common addressing character. Code POLL and ADDR on the TERMINAL definition statement to define the common polling and addressing characters.

## SERVICE

ORDER on the SERVICE definition statement specifies the sequence of the entries in the service order table for nonswitched links and whether NCP is to make more than one poll per cycle. Upon request from the access method, NCP attempts to establish sessions with devices and components in the same sequence as their respective entries appear in the service order table. If you do not specify ORDER, the NCP/EP definition facility (NDF) builds a service order table with entries in the order of device definition in the system generation definition.

**3746 Model 900 SDLC Lines:** The 3746 Model 900 assigns a polling weight based on the number of times a station is defined in the service order table. If ORDER is not specified, a value of one is used for each station. For example,

ORDER=(S1,S2,S3,S1,S1,S1,S1,S2) results in the following polling sequence: S1,S2,S3,S1,S2,S1,S1,S1. S1 has a polling weight of 5. S2 has a polling weight of 2. S3 has a polling weight of 1.

### CLUSTER

GPOLL on the CLUSTER definition statement defines the general polling characters to be used when NCP polls a cluster controller with attached BSC devices. A general poll enables the cluster controller to respond when data has been collected and queued from attached devices. If you do not define general polling characters, NCP must poll each device individually.

### TERMINAL

ADDR on the TERMINAL definition statement specifies the hexadecimal address of a BSC or start-stop device.

POLL specifies the hexadecimal polling character you assign to a BSC or start-stop device.

SESSREQ specifies whether a session must exist before NCP polls the device for data. SESSREQ=YES is recommended for environments where the application directly initiates the sessions.

### COMP

ADDR on the COMP definition statement specifies the hexadecimal address of the output component of a BSC or start-stop device. You do not need to code ADDR if the device is used for input only.

POLL specifies the hexadecimal polling character you assign to the input component of a BSC or start-stop device. You do not have to code POLL if the device is used for output only.

### Sample Definition of Polling and Addressing Specifications

Figure 5-25 on page 5-42 shows how to define a polling sequence and addresses for attached devices.

## Polling and Addressing

```
GA03BSC1 GROUP LNCTL=BSC,      BSC line control
                    TYPE=NCP      Lines operate in network control mode
*
LA03000  LINE  ADDRESS=000,      Relative line number
                    AVGPB=150,    150 bytes expected when polled
                    POLIMIT=(10,QUEUE), Negative poll response, request queued
                    POLLED=YES,    Polled lines
                    SESSION=3      3 concurrent sessions
*
                    SERVICE ORDER=(CA03000,TA03000A,TA03000B) Order of line service
*
CA03000  CLUSTER CUTYPE=3271,    IBM Model 3271 control unit
                    GPOLL=40407F7F Define general polling characters
*
TA03000A TERMINAL ADDR=60604040, Hexadecimal terminal address
                    CONV=YES,      NCP sends message block as a response
                    DIRECTN=INOUT, Sends and receives text
                    POLL=40404040, Device polling characters
                    TERM=3277      Type of device to communicate with
*
TA03000B TERMINAL ADDR=6060C1C1, Hexadecimal terminal address
                    CONV=YES,      NCP sends message block as a response
                    POLL=4040C1C1, Device polling characters
                    TERM=3277      Type of device to communicate with
```

Figure 5-25. Example: Defining Polling and Addressing

## IBM 3174 Group Poll

Group polling is a process that sends a single poll to one collection point for a group of stations, inviting a response from any station in the group that has data to send. The IBM 3174 group poll function improves performance for IBM Token-Ring Networks when an IBM 3174 controller acts as a gateway for a Token-Ring network connected to NCP over an SDLC link.

Code the following keywords to provide NCP with information about the group address and the physical connection of the link.

```
PU          GP3174
           MODULO
           PUTYPE
```

GP3174 on the PU definition statement assigns a group address to the IBM 3174 controller. This keyword indicates that an Unnumbered Poll (UP) SDLC frame containing the group address can be answered by any station associated with the group. You can define a group address only for nonswitched SDLC lines. PU definition statements that include the GP3174 keyword do not have to be coded consecutively. A multipoint line with devices that are not group polled can require a user-defined service order sequence to maximize performance.

MODULO specifies how many information frames are to be sent to a device before a response is required. Code MODULO=8 when you define a group address.

PUTYPE defines the SDLC physical unit type. Code PUTYPE=2 when you define group polling.



## Sample Definition of IBM 3174 Group Polling

Figure 5-26 shows how to define group polling.

GRPOLL	GROUP	LNCTL=SDLC, DIAL=NO	SDLC line control Lines are not switched
*			
B75S16	LINE	ADDRESS=(016,FULL), CLOCKNG=EXT, DUPLEX=FULL, MODULO=8, PAUSE=2.0, MODETAB=NRFL0G, NRZI=NO, TRANSFER=20, USSTAB=AUSSTAB	Relative line number Modem provides clocking Duplex line Line operating as modulo 8 line 2-second pause between polls VTAM-only keyword DTE not in NRZI mode 20 NCP buffers for receiving data VTAM-only keyword
*			
B75P16C1	PU	ADDR=C1, GP3174=A1 PUTYPE=2	Hexadecimal physical unit address 3174 group poll address is A1 Physical unit type
*			
B75L162A	LU	LOCADDR=2	Local address of logical unit
*			
B75L162B	LU	LOCADDR=3	Local address of logical unit

Figure 5-26. Example: Defining the IBM 3174 Group Poll

## Data Characteristics

Data characteristics must be defined to NCP so that NCP can convert other data formats into EBCDIC for internal processing and provide a transmission control scheme for the data.

Code the following definition statements and keywords to provide NCP with information about the transmission code to be used and the transmission control characters.

LINE	CODE
CLUSTER	ITBMODE
TERMINAL	ITBMODE
COMP	ITBMODE

### LINE

CODE on the LINE definition statement specifies the transmission code used with BSC or start-stop devices attached to the link. NCP translates outgoing data from its internal processing code, EBCDIC, into the specified code, or it translates incoming data from the specified code into EBCDIC. NCP does not perform code translation for a link operating in emulation mode. Emulation mode data is sent in the same transmission code in which it is received.

## Data Characteristics

### Notes:

1. For BSC links, specify the presentation scheme and transmission code to use because the two values are related for BSC devices. CODE identifies the presentation scheme NCP is to use and, for BSC links operating in emulation mode, the transmission code (EBCDIC or ASCII) to be used. If you have a 3270 or 3275 BSC link using ASCII transmission code, the 3275 does the character code translation.
2. For start-stop links, the transmission code used on a multipoint link must be the same for all devices attached to that link. A translation table within NCP is associated with each transmission code. *NCP and EP Reference Summary and Data Areas, Volume 2*, defines the contents of the translation tables. For start-stop links operating in emulation mode, NCP does not need to know the transmission code used.

### CLUSTER

ITBMODE on the CLUSTER definition statement specifies whether NCP is to insert and delete error-information-block (EIB) characters following each intermediate-text-block (ITB) character received from or sent to the cluster controller.

### TERMINAL

ITBMODE on the TERMINAL definition statement specifies whether NCP is to insert and delete EIB characters following each ITB character received from or sent to the BSC device.

### COMP

ITBMODE on the COMP definition statement specifies whether NCP is to insert and delete EIB characters following each ITB character received from or sent to the input or output component of the BSC device.

In all cases, ITBMODE determines whether each ITB character received from or sent to the access method is followed by an EIB character. If you specify insertion of EIBs for data sent to the host, the application program in the host processor can scan the error information byte of the ITB to determine whether an error occurred in the intermediate block. If you specify that each ITB character received from the access method is followed by an EIB character, NCP removes the first character following each ITB it detects.

### Sample Definition of Data Characteristics

Figure 5-27 on page 5-45 shows how to define data characteristics to NCP.

```

GA01BS2 GROUP LNCTL=BSC,      BSC line control
          TYPE=NCP            Lines operate in network control mode
*
L001003 LINE ADDRESS=(003,HALF), Relative line number
          CODE=EBCDIC,        Transmission code is EBCDIC
          CLOCKNG=EXT,        Modem provides clocking
          DUPLEX=FULL         Duplex line
*
CA03000 CLUSTER CUTYPE=3271   IBM model 3271 control unit
*
TA03000A TERMINAL CONV=YES,   NCP sends message block as a response
          DIRECTN=INOUT,      Sends and receives text
          TERM=3277           Type of device to communicate with
*
TA03000B TERMINAL CONV=YES,   NCP sends message block as a response
          TERM=3277           Type of device to communicate with

```

Figure 5-27. Example: Defining Data Characteristics

## End of Transmission

NCP is notified that data transmission is complete for start-stop devices when it encounters an end-of-transmission character. Code the following definition statements and keywords to provide NCP with information about the character used to end data transmission.

```

TERMINAL    ENDTRNS
COMP        ENDTRNS

```

ENDTRNS on the TERMINAL definition statement specifies whether NCP considers a transmission from the start-stop device terminated by either an end-of-transmission (EOT) character or an end-of-block (EOB) character.

ENDTRNS on the COMP definition statement specifies whether NCP considers a transmission from the input or output component of the start-stop device terminated by either an EOT or an EOB character.

### Sample Definition of End of Transmission

Figure 5-28 shows how to define an end-of-transmission character.

```

TA04000A TERMINAL ENDTRNS=EOB    Transmission ended by EOB character

```

Figure 5-28. Example: Defining the End of Transmission

---

### Delay between Successive Transmissions for Buffered Devices

When NCP sends multiple data blocks to the same device, it waits after sending each block before sending the next block. This gives the receiving device time to print the contents of its buffer before it receives the next block. The following are buffered BSC devices that receive incoming data into buffers at a high speed and then present the data at a much slower speed:

- IBM 2740 Communication Terminal (Model 2)
- IBM 2770 Data Communications System
- IBM 3275 Display Station
- IBM 3284 Printer
- IBM 3286 Printer
- IBM 3780 Data Communications Terminal.

Code the following definition statement and keyword to provide information to NCP about the interval between successive transmissions for buffered devices.

```
TERMINAL      BFRDLAY
```

BFRDLAY on the TERMINAL definition statement specifies how long NCP waits after sending a block of data to the device before sending the next one. If the buffered device is attached to a nonswitched multipoint link, NCP can use the time the link would otherwise be idle to communicate with other devices. At any given moment NCP can send data to one of several devices while the others display or print data received earlier. Code BFRDLAY if a device is a buffered device and is attached to a nonswitched multipoint link.

#### Sample Definition of Delay between Successive Transmissions

Figure 5-29 shows how to define the delay between successive transmissions to buffered devices.

```
TA05000A TERMINAL BFRDLAY=20,      Delay 20 seconds between transmissions
                TERM=3275           Type of device to communicate with
```

Figure 5-29. Example: Defining the Delay between Successive Transmissions

---

## Chapter 6. Token-Ring Resources

NCP Token-Ring support enables NCP to function as a node in an IBM Token-Ring Network using Institute of Electrical and Electronic Engineers (IEEE) standard 802.5. NCP Token-Ring resources provide logical point-to-point connections between NCP and other nodes in the network.

NCP supports NCP/Token-Ring interconnection (NTRI) using the type 1 and type 2 TICs. NCP also supports a Token-Ring attachment through the 3746 Model 900 connectivity subsystem (CSS) using the type 3 TIC. The 3746 Model 900 improves NCP performance by performing NCP data link control functions. To use a 3746 Model 900, you need to obtain a license for the NCP 3746 Model 900 Feature from IBM.

See “3746 Model 900 Connectivity Subsystem” on page 3-6 for an introduction to the 3746 Model 900. For more information about how to define an NCP generation definition that includes 3746 Model 900 Token-Ring resources, see “Defining the NCP Environment” on page 2-5.

**Frame-Relay and Internet-Protocol (IP) Support over Token-Ring Resources:** You can switch frame-relay frames and route IP datagrams over NTRI attachments through a type 1 or type 2 TIC. NCP can communicate simultaneously over a NTRI physical line with SNA devices using a connection-oriented protocol, with internet devices using a connectionless protocol, and with another NTRI frame handler switch using a connectionless protocol.

Use this chapter when defining SNA logical lines using NTRI physical lines. Refer to “Defining NTRI Attachments for IP” on page 15-31 or “Defining NTRI Attachments for a Frame-Relay Network” on page 16-63 when defining internet or frame-relay support for NTRI attachments. Refer to “Defining an Internal NCP to Model 900 Point-to-Point IP Connection” on page 15-39 when defining an internal point-to-point IP connection between the 3745 router and the 3746 Model 900 router.

NTRI provides guaranteed bandwidth for the specified Token Ring physical resources that represent distinct protocols (for example, SNA or IP). COMRATE, defined for each protocol, is used to disperse a percentage of the physical line's total bandwidth to each protocol. The SNA protocol's bandwidth is allocated a frame at a time to all of the SNA logical links, in a round robin fashion. In comparison, the IP protocol's bandwidth is allocated first-in first-out (FIFO). A percentage of the frame relay protocol's bandwidth is dispersed among the associated NTRI frame handler logical lines, and each frame handler logical line's bandwidth is dispersed to its frame handler stations.

You will understand this chapter better if you are familiar with the terminology used to describe types of connections.

### Type of

### Connection Description

Physical

The physical connection of NCP to the Token Ring is a non-switched duplex line. Define one physical line for each Token-Ring interface coupler.

## Token-Ring Resources

Logical	The logical connection of NCP to a Token-Ring station is a half-duplex line. Define the logical connection as peripheral or subarea based on the node type of the station connected to it. The logical connection is determined to be local or remote based on the Token-Ring network topology.
Peripheral	The connection between NCP and a peripheral node (a type 2 or type 2.1 physical unit) is a switched line.
Subarea	The connection between NCP and a subarea node (a type 4 or type 5 physical unit) is a nonswitched line.
Frame Handler	The connection between NCP (a type 1 physical unit) and a destination NCP (a type 1 physical unit) to which frame-relay frames can be switched is a nonswitched line.
Local	A local connection is a logical connection to a station on the same ring segment.
Remote	A remote connection is a logical connection to a station on a different ring segment, connected by way of one or more bridges.
Remote LAN	A remote LAN is a remote connection that includes a remote bridge (split bridge), which transfers Token-Ring frames across a wide area network to another Token Ring.

Figure 6-1 on page 6-3 shows physical and logical lines in both Token-Ring peripheral and subarea links.

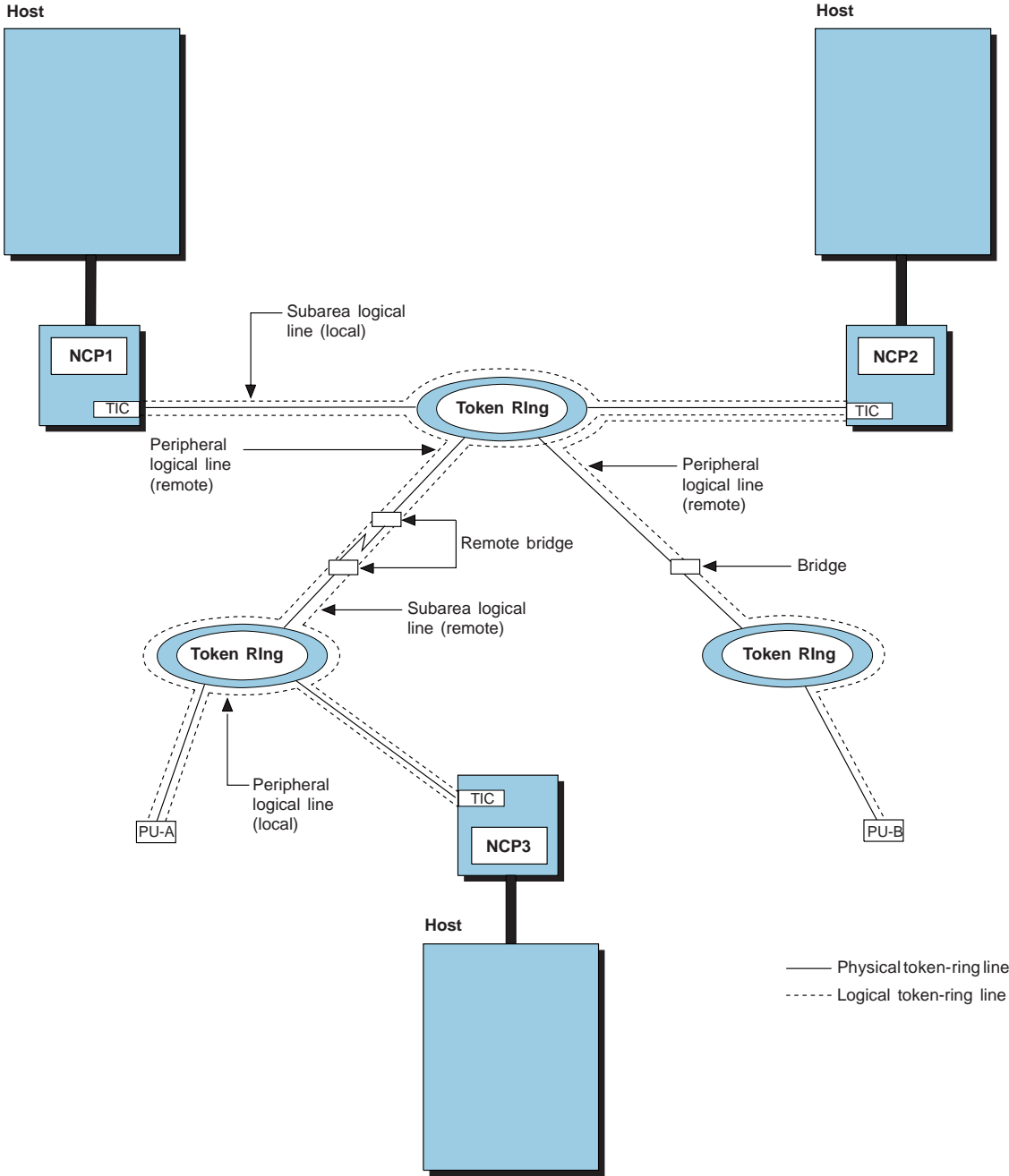

Figure 6-1. Token-Ring Physical and Logical Connections

### Defining Token-Ring Resources

Token-Ring physical lines are defined using GROUP, LINE, and PU definition statements. You can define up to eight NTRI physical lines and up to thirty-three 3746 Model 900 Token-Ring physical lines, depending on the controller model. These definition statements must appear in the system generation definition before the Token-Ring logical line definitions.

## Defining Token-Ring Resources

Token-Ring logical lines are defined using GROUP, LINE, and PU definition statements. You can define a total of 9999 logical lines used in association with a Token-Ring or frame-relay physical connection. The logical line definitions must follow the physical line definitions in your generation definition.

For NTRI resources and peripheral 3746 Model 900 Token-Ring resources, use either the PHYPORT or PHYRSC keyword to associate SNA logical lines with physical lines. For subarea 3746 Model 900 Token-Ring resources, use only the PHYRSC keyword to define this relationship. If you are defining peripheral resources, you can define an unassigned pool of logical lines to be assigned as needed to physical lines during connection establishment. NCP uses separate unassigned pools for NTRI logical lines and for 3746 Model 900 Token-Ring logical lines.

**Note:** For NTRI frame handler logical lines, use PHYRSC. PHYPORT is not allowed. See “Defining NTRI Frame Handler Logical Links” on page 16-66 for more information.

Some Token-Ring characteristics and functions to define in the system generation definition are:

- Adapter type
- Automatic line and physical unit generation using the AUTOGEN facility
- Duplicate TIC addressing
- Frame size
- TIC swap capability
- Timing requirements
- Unassigned logical line pools.

These are discussed in more detail in later sections of this chapter.

When defining Token-Ring resources, code NEWDEFN=(YES,...) to cause NDF to create a new generation definition (*NEWDEFN file*), which must be used to define the NCP major node in the VTAM system definition. For more information on NEWDEFN files, see “NDF-Generated Definition File” on page 2-1.

## NDF-Generated Additions for Token-Ring Resources

When you code NEWDEFN on the OPTIONS definition statement and ECLTYPE on the GROUP definition statement to define Token-Ring resources, NDF generates additional keywords and appropriate values to simplify the generation process. NDF adds these keywords to the output generation file in addition to the definition statements and keywords you code. The following sections describe the keywords added when you define physical and logical Token-Ring lines.

### Physical Lines

Figure 6-2 on page 6-5 shows the NDF-generated keywords that are added to your definition file when you define Token-Ring physical lines.



GROUP	COMPOWN=YES,	NTRI only
	COMPSWP=YES,	NTRI only
	COMPTAD=YES,	NTRI only
	DIAL=NO,	
	LEVEL2=ECLNARL2,	NTRI only
	LEVEL3=ECLNARL3,	NTRI only
	LEVEL5=NCP,	NTRI only
	LNCTL=SDLC,	
	NPACOLL=NO,	
	PUDR=NO,	
	PUTYPE=1,	
	SPEED=9600,	
	TIMER=(ECLNART1,,ECLNART2,ECLNART3),	NTRI only
	TYPE=NCP,	
	USERID=(5668854,ECLRBDT,NORECMS,,ECLNMVT),	NTRI only
	XIO=(ECLNARXL,ECLNARXS,ECLNARXI,ECLNARXK)	NTRI only
LINE	TRSPEED= <i>a</i> , 1	
	UACB=(X\$P <i>n</i> AX,X\$P <i>n</i> AR)	NTRI only <sup>2</sup>
PU	ADDR= <i>nn</i> , 3	
	ANS=CONTINUE,	
	INNPORT=YES <sup>4</sup>	
LU	LOCADDR=0	

<sup>1</sup> *a* is 4 for TIC1, 16 for TIC2 and TIC3.  
<sup>2</sup> *n* is a counter that is incremented for each physical line.  
<sup>3</sup> *nn* is 01 when NETWORK=SNA is defined or no network is coded on the PU definition statement.  
*nn* is 02 when NETWORK=IP.  
*nn* is 03 when NETWORK=FRELAY is coded.  
<sup>4</sup> Added when ECLTYPE=(PHYSICAL,SUBAREA) or ECLTYPE=(PHYSICAL,ANY) is coded on the GROUP definition statement. Not added when ECLTYPE=PHYSICAL and ADAPTER=TIC1 are coded on the GROUP definition statement.

Figure 6-2. NDF-Generated Keywords for Token-Ring Physical Lines

### Logical Lines

Figure 6-3 on page 6-6 shows the NDF-generated keywords that are added to your definition file when you define Token-Ring logical peripheral lines.

## Defining Token-Ring Physical Connections

GROUP	COMPOWN=YES, DIAL=YES, LEVEL2=ECLNAVL2, LEVEL3=ECLNAVL3, LEVEL5=NCP, LINEADD=NONE, LINEAUT=YES, LNCTL=SDLC, NPACOLL=NO, PUTYPE=2, RETRIES=(6,0,0,6), TYPE=NCP, USERID=(5668854,ECLVBDT,NORECMS,,ECLNMVT), XIO=(ECLNAVXL,ECLNAVXS,ECLNAVXI,ECLNAVXK), XMIDLY=NONE	NTRI only  NTRI only NTRI only NTRI only NTRI only   NTRI only NTRI only NTRI only
LINE	UACB=(X\$LnA)	NTRI only <sup>1</sup>
GENEND	INIT=ECLINIT, TMRTICK=ECLTICK, UGLOBAL=ECLUGBL	NTRI only NTRI only NTRI only

<sup>1</sup> n is a counter that is incremented for each logical line.

Figure 6-3. NDF-Generated Keywords for Token-Ring Logical Peripheral Lines

Figure 6-4 shows the NDF-generated keywords that are added to your definition file when you define Token-Ring logical subarea lines.

GROUP	COMPOWN=YES, DIAL=NO, LEVEL2=ECLNAVL2, LEVEL3=ECLNAVL3, LEVEL5=NCP, LINEADD=NONE, LNCTL=SDLC, NPACOLL=NO, PUTYPE=4, RETRIES=(6,0,0,6), TYPE=NCP, USERID=(5668854,ECLVBDT,NORECMS,,ECLNMVT), XIO=(ECLNAVXL,ECLNAVXS,ECLNAVXI,ECLNAVXK)	NTRI only  NTRI only NTRI only NTRI only NTRI only   NTRI only NTRI only
LINE	UACB=(X\$LnA)	NTRI only <sup>1</sup>
GENEND	INIT=ECLINIT, TMRTICK=ECLTICK, UGLOBAL=ECLUGBL	NTRI only NTRI only NTRI only

<sup>1</sup> n is a counter that is incremented for each logical line.

Figure 6-4. NDF-Generated Keywords for Token-Ring Logical Subarea Lines

## Defining Token-Ring Physical Connections

Define at least one physical line group for each Token-Ring interface coupler (TIC) that connects the communication controller to the Token-Ring network. The NCP physical connection to the Token Ring is defined as a nonswitched duplex line. If you want to define a Token-Ring subarea link, see “Defining Token-Ring Physical Subarea Connections” on page 6-28 for more information.

## Defining Token-Ring Physical Connections

Whether you are defining NTRI or 3746 Model 900 Token-Ring connections, there are certain physical characteristics to be defined that are common to both types of Token-Ring connections.

To define a Token-Ring physical connection to switch frame-relay frames, refer to “Defining NTRI Attachments for a Frame-Relay Network” on page 16-63

**Note:** Before data can be transmitted over a Token-Ring logical line, all the physical resources that support the logical line must be active. You can use NTuneMON to determine the status of Token-Ring physical resources. See the *NTuneMON User's Guide* for more information.

Code the following definition statements and keywords to provide NCP with information about the type of adapter and its address, the connection to the Token Ring, transmission characteristics, and how to recover from errors.

GROUP	ADAPTER ECLTYPE
LINE	ADDRESS BALANCE <sup>3</sup> BEACTO DATBLK LOCADD LSPRI MAXTSL NPACOLL PORTADD RCVBUFC TRSPEED
PU	ADDR ANS COMRATE <sup>1</sup> NETWORK PASSLIM <sup>2</sup> XMONLNK

<sup>1</sup> Supported starting with NCP V7R3.  
<sup>2</sup> Supported only for NCP V7R1 and NCP V7R2 releases.  
<sup>3</sup> Supported starting with NCP V7R6 for NTRI, and NCP V7R8 for 3746 Model 900.

### GROUP

ADAPTER on the GROUP definition statement defines the type of TIC in the communication controller:

- Code ADAPTER=TIC1 to define a type 1 TIC (4 Mbps).
- Code ADAPTER=TIC2 to define a type 2 TIC (4 or 16 Mbps).
- Code ADAPTER=TIC3 to define a type 3 TIC (4 or 16 Mbps).

## Defining Token-Ring Physical Connections

For NTRI, you can code ADAPTER on the GROUP or LINE definition statement. For 3746 Model 900 Token Ring, code ADAPTER only on the GROUP definition statement.

A type 2 TIC has all the features of a type 1 TIC, so you can define a type 2 TIC as a type 1 TIC. The type 2 and type 3 TICs are functionally equivalent except that the type 2 TIC is used for NTRI and the type 3 TIC is used for 3746 Model 900 Token Ring.

The type 2 and type 3 TICs have the following advantages over the type 1 TIC:

- A type 1 TIC can support either subarea or peripheral traffic, but not both. A type 2 or type 3 TIC can support both subarea and peripheral traffic.
- The type 2 and type 3 TICs can attach to a 16-Mbps Token-Ring for higher data transfer speed. In addition, when you code TRSPEED=16, NCP supports early token release.
- Larger adapter memory greatly reduces adapter congestion and permits larger frames to be sent and received.

**Note:** For a type 2 or type 3 TIC, you can specify a larger MAXTSL value than for a type 1 TIC. For a type 2 TIC, you can specify a larger RCVBUFC value than for a type 1 TIC. RCVBUFC is ignored for a type 3 TIC.

ECLTYPE identifies the type of token-ring resources defined by the line group. These are the ways to define the resources:

- ECLTYPE=PHYSICAL defines a physical line group. For a type 1 TIC, the second suboperand defaults to PERIPHERAL. For a type 2 or type 3 TIC, the second suboperand defaults to ANY.
- ECLTYPE=(PHYSICAL,PERIPHERAL) defines a physical line group that supports only peripheral node connections.
- ECLTYPE=(PHYSICAL,SUBAREA) defines a physical line group that supports only subarea connections.
- ECLTYPE=(PHYSICAL,ANY) defines a physical line group that can support subarea connections, peripheral connections, or a combination of both on the same TIC. Code ADAPTER=TIC2 or ADAPTER=TIC3 if you specify ANY on ECLTYPE.

**Note:** The second argument of ECLTYPE does not effect the support of IP or frame relay attachments.

## LINE

ADDRESS on the LINE definition statement specifies the position of the line or TIC in the communication controller. Consult *NCP, SSP, and EP Resource Definition Reference* for the correct value for your controller model since each controller model accepts a specific range of values. Remember that for each even or odd pair of available NTRI line addresses, the line definition using the even address must precede the one using the odd address. BALANCE on the LINE definition statement specifies the *connection balancing factor* for Token-Ring physical lines with duplicate locally administered MAC addresses (*duplicate TIC addressing*) participating in *connection balancing*.

**Connection Balancing:** As part of establishing a peripheral connection via an incoming call request, the initiating device sends route discovery frames to a specific MAC address. In a duplicate TIC environment, the peripheral

device generally connects through the TIC that responds first to its route discovery frames.

Connection balancing distributes, across all duplicate TICs, incoming call requests initiated by downstream peripheral devices. For each TIC participating in the balancing function, the number of supported logical connections is tracked. Based on this count and the TICs balancing factor, the TIC delays sending a response to the initiating device's route discovery frames allowing the connection to establish through alternate duplicate TICs. To prevent a potential broadcast storm of retransmitted route discovery frames by the peripheral devices, the delay time is restricted to a 0.9 second maximum.

Because connection balancing is performed independently by each duplicate TIC, there is no limit to the number of TICs that can participate in the balancing scheme. However, in order for the balancing mechanism to function properly, all associated duplicate TICs must have nonzero balancing factors if any one of the associated duplicate TICs is performing connection balancing.

**Linear Connection Balancing (NTRI and 3746 Model 900):** When you specify a numerical value for BALANCE, a fixed balancing algorithm is used. Based on the balancing factor and the TIC's number of supported connections, the algorithm uses the following expression to determine the time delay for responding to route discovery frames:

$$\text{Delay} = (\text{number\_of\_connections} / (\text{balancing\_factor} * 16)) * 0.1 \text{ seconds}$$

In effect,  $(\text{balancing\_factor} * 16)$  determines the connection granularity of the TIC. A zero balancing factor implies that the TIC will not perform connection balancing and will respond normally to received peripheral route discovery frames.

Conversely, a balancing factor of one equates to a 16-connection granularity. After 16 peripheral connections have been established, the TIC would introduce 0.1 seconds delay before sending a response to any route discovery frames. This would allow the other duplicate TICs with fewer connections to honor the incoming call requests. Furthermore, this delay would increase to a 0.2 seconds delay after 32 peripheral connections had been established.

In contrast, a balancing factor of 16 equates to a 256-connection granularity. After 256 peripheral connections have been established, the TIC would introduce a 0.1 second delay before sending a response to any route discovery frames. After 512 connections were established, the TIC would introduce a 0.2 seconds delay. This would continue to increase by 0.1 increments until a 0.9 seconds delay was reached.

You can determine an appropriate balancing factor for all associated duplicate TICs by dividing the total number of DSPUs supported by the duplicate TIC environment by 160 and rounding to the nearest integer from 1 through 16.

## Defining Token-Ring Physical Connections

**Auto-Adaptive Connection Balancing (3746 Model 900 only):** When you specify `BALANCE=AUTO`, a logarithmic balancing algorithm is used. The algorithm dynamically adjusts the time delay, for responding to route discovery frames, as new connections are established.

When the TIC supports a small number of connections, the time delay increases more quickly as new connections are added. Conversely, when a large number of connections is supported, the time delay increases gradually as connections are established.

Unlike the fixed balancing algorithm, you are not required to specify an appropriate numerical balancing factor for all associated duplicate TICs that provide the auto-adaptive balancing function.

Refer to the *3745 Communications Controller Model A, 3746 Nways Multi-protocol Controller Models 900 and 950 Planning Series: Token Ring and Ethernet, GA27-4236*, for more information about the Model 900 auto-adaptive balancing processing.

BEACTO identifies the beaconing timeout value, which is the length of time NCP pauses to allow a failed Token Ring to recover. If the Token Ring cannot recover from the beaconing condition before the time coded on BEACTO elapses, the logical connections over the physical line become inoperative. If the Token Ring recovers within the time coded on BEACTO, all SNA logical connections remain operative. Refer to *NCP and EP Reference* for further information on beaconing.

DATABLK specifies the minimum transmission bandwidth in bytes that can be allocated to an NTRI resource. DATABLK is used with the *priority* suboperand of the COMRATE keyword to determine a relative priority among protocols. The value of the *priority* suboperand of COMRATE is multiplied by the value of DATABLK to determine the guaranteed minimum number of bytes provided for a protocol for the transmission of associated traffic before a different protocol is provided a transmission opportunity. See "NTRI on page 6-12" for information about coding COMRATE.

LOCADD identifies the 6-byte hexadecimal hardware address of the TIC connecting NCP to an IBM Token-Ring Network. You can assign duplicate LOCADDs to a group of lines. For NCP V7R4 and earlier releases, you cannot assign duplicate LOCADDs to physical lines that support either subarea traffic or frame-relay traffic. Starting in NCP V7R5, you can assign duplicate LOCADDs to physical lines that support subarea traffic. However, only one of these physical lines can support frame-relay traffic. See "Duplicate TIC Addressing" on page 6-16 for more information about assigning duplicate addresses.

**3746 Model 900 Token Ring:** If you use a 3746 Model 900 controller bus and service processor (CBSP) Token-Ring connection, code `ADDRESS=2080`, `TRSPEED=16` (`TRSPEED=4` is invalid), `BEACTO=52`, and the LOCADD value generated when the Service Processor LAN is installed. See "3746 Model 900 Service Processor LAN" on page 6-34 for more information.

LSPRI specifies whether transmission priority is to be used to determine the order in which PIUs are sent to the physical unit. LSPRI is valid only for peripheral physical Token-Ring lines. Code `LSPRI=NO` or `LSPRI=PU` when you define the following:

- ECLTYPE=(PHYSICAL,PERIPHERAL)
- ECLTYPE=(PHYSICAL,ANY).

Code LSPRI=NO if you code ECLTYPE=(PHYSICAL,SUBAREA).

**Note:** It is useful to code the LSPRI keyword when a gateway is used to connect remote workstations that appear as separate logical units to NCP.

MAXTSL specifies the maximum amount of data, including the transmission header, the request header, and the response unit, that NCP is to transmit in a single Token-Ring frame. MAXTSL has different ranges and defaults depending on ECLTYPE, ADAPTER, and TRSPEED values. See “Frame Size” on page 6-40 and “Multilink Transmission Groups” on page 12-16 for information on how to use MAXTSL.

NPACOLL specifies whether the Token-Ring physical line is eligible for performance data collection through NPM.

PORTADD assigns a port identification number (0–99) used to identify the TIC to VTAM. Depending on your VTAM release, you must code the PORTADD identification number as one of the following:

- First 2 digits of the DIALNO value on the VTAM PATH definition statement
- *nn* value for DLCADDR=(2,D,*nn*), which is coded on the VTAM PATH definition statement in the switched major node

To perform dial-out processing over duplicate TIC addresses, code the same PORTADD and LOCADD value for the physical line definition associated with each TIC. See “Duplicate TIC Addressing” on page 6-16 for more information.

**NTRI:** To associate a group of SNA logical lines with one or more physical lines with the same PORTADD, code the PORTADD value on the PHYPORT keyword on the logical line GROUP definition statement. Alternatively for NTRI subarea resources, you can substitute PHYSRSC, which has the advantage of causing VTAM to defer activation of subarea logical lines associated with a physical station until the station is activated. See “Defining Token-Ring Logical Connections” on page 6-20 for more information on PHYPORT and PHYSRSC.

**3746 Model 900 Token Ring:** PHYPORT can be used for peripheral logical resources.

**Note:** PHYPORT cannot be used to associate NTRI frame handler logical lines with NTRI physical lines. PHYSRSC must be used. It must specify the physical PU with NETWORK=FRELAY associated with the NTRI physical line.

RCVBUFC defines the NCP buffer capacity for receiving NTRI data from an IBM Token-Ring Network during one data transfer. The RCVBUFC value must be greater than or equal to the maximum number of bytes that will be received in one data transfer operation. One data transfer operation includes the IEEE 802.5 physical link header, the IEEE 802.2 logical link control (LLC) header, the transmission header, and the request/response header. The RCVBUFC minimum value is 6 times the value coded on BFRS; the RCVBUFC maximum value depends on the type of adapter. The default value assigned to RCVBUFC depends on values coded on the ADAPTER and ECLTYPE keywords. Code RCVBUFC only for NTRI connections; see “Frame Size” on page 6-40 for more details on how to use RCVBUFC.

## Defining Token-Ring Physical Connections

**3746 Model 900 Token Ring:** RCVBUFC is ignored for 3746 Model 900 Token-Ring connections.

TRSPEED defines a Token-Ring speed of 4 Mbps or 16 Mbps. TRSPEED=16 is valid only for a type 2 or type 3 TIC. If you do not code a TRSPEED value, NDF assumes 4 Mbps for a type 1 TIC and 16 Mbps for a type 2 or type 3 TIC. See “Token-Ring Speed” on page 6-39 for more details.

### PU

ADDR on the PU definition statement defines the link station address of the physical unit. Code ADDR=01 for an SNA Token-Ring attachment.

**NTRI:** See “Defining NTRI Attachments for IP” on page 15-31 or “Defining NTRI Attachments for a Frame-Relay Network” on page 16-63 for more information on coding ADDR.

**Internal NCP to Model 900 Point-to-Point IP Connections:** See “Defining an Internal NCP to Model 900 Point-to-Point IP Connection” on page 15-39 for more information on coding ADDR.

ANS specifies whether the Token-Ring physical line continues operating if your NCP enters automatic network shutdown (ANS). Automatic network shutdown occurs for those devices started by a particular access method when NCP can no longer communicate with that access method.

Although the SNA physical unit definitions for physical lines define only a dummy physical unit, the value of the ANS keyword associated with this physical unit is used to determine what action to take for the physical line during automatic network shutdown. From an operations point of view, activation of the line resource is all that is required to make the physical line operational. Contacting the physical unit resource and subsequently discontacting the physical unit resource does not affect operation of the physical line. However, during shutdown, if the last owner of the line is no longer present, the action that NCP takes depends on the values of the ANS and XMONLNK keywords.

If you code ANS=STOP, the physical line is deactivated and the TIC is removed from the ring. If you omit the ANS keyword or code ANS=CONTINUE, the physical line is treated as a nonswitched SDLC line, and the TIC remains inserted on the ring. If there is still an owner of the line, the line remains active during automatic network shutdown, regardless of how the ANS keyword is coded.

If you code multiple PU definition statements under the same LINE definition statement, code the same value for ANS on each PU definition statement.

COMRATE on the PU definition statement specifies the relative priority of a protocol (SNA, IP, or frame relay), as represented by the physical units defined on a NTRI physical line, as compared to all other protocols on a NTRI physical line. You should code COMRATE=(,priority). The value of the *priority* suboperand of COMRATE is multiplied by the value of DATBLK on the LINE definition statement to determine the guaranteed minimum number of bytes that a protocol can transmit before another protocol must be given a transmit opportunity.

The relative priority of a protocol on a Token-Ring physical line can be determined as a fraction of the total available transmission opportunity dispersed to all defined protocols. This fraction is calculated by dividing the COMRATE *priority* value of the



physical unit representing the protocol on the line by the sum of the *priority* values of all the protocols on the physical line.

$$\frac{\text{Protocol 1's } \textit{priority} \text{ value}}{\text{The sum of } \textit{priority} \text{ values of all protocols on the physical line}}$$

The sum of *priority* values of  
all protocols on the physical line

For example, if there are three PUs on a line, PU1's transmission fraction is determined like this:

$$\frac{\text{PRIORITY}_{\text{PU1}}}{\text{PRIORITY}_{\text{PU1}} + \text{PRIORITY}_{\text{PU2}} + \text{PRIORITY}_{\text{PU3}}}$$

(PRIORITY = The value of the *priority* suboperand of the COMRATE keyword.)

See page 6-10 for more information about the DATBLK keyword.

NETWORK specifies whether this physical unit represents a connection to an SNA network, frame-relay network, or an internet. To define a physical unit to support SNA logical lines, either omit NETWORK or code NETWORK=SNA.

**NTRI:** See "Defining NTRI Attachments for IP" on page 15-31 and "Defining NTRI Attachments for a Frame-Relay Network" on page 16-63 for more information on coding NETWORK.

**Internal NCP to Model 900 Point-to-Point IP Connections:** See "Defining an Internal NCP to Model 900 Point-to-Point IP Connection" on page 15-39 for more information on coding NETWORK.

PASSLIM determines the maximum number of consecutive Token-Ring SNA frames NCP is to transmit before checking for Token-Ring internet frames to be transmitted. PASSLIM can help you control the mixture of internet and SNA traffic over a NTRI attachment. For NCP V7R3 and later, a mechanism for sharing bandwidth between network protocols associated with COMRATE on the PU definition statement replaces the mechanism associated with PASSLIM.

XMONLNK specifies whether the SSCP monitor mode function (SMMF) is to activate the physical line.

### Sample Definition of Token-Ring Physical Connections

Figure 6-5 on page 6-14 shows an example of a NTRI physical connection to Token Ring A and a 3746 Model 900 physical connection to Token Ring B.

## Defining Token-Ring Physical Connections

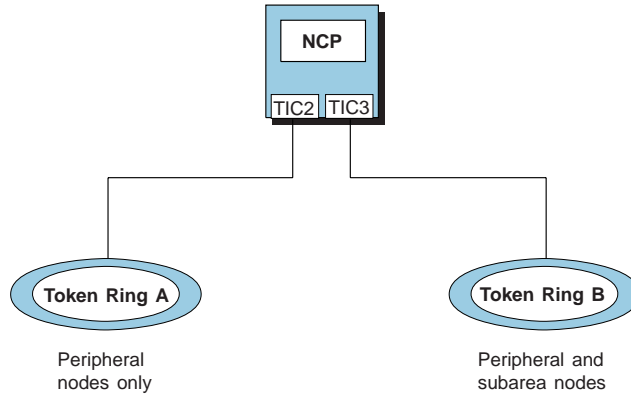

Figure 6-5. Type 2 and Type 3 Token-Ring Physical Connections

Figure 6-6 shows how to define the NTRI and 3746 Model 900 physical connections shown in Figure 6-5. The only difference between the two types of connections is that the 3746 Model 900 connection uses a type 3 TIC and the line address is valid for 3746 Model 900 hardware. The connections to both Token Rings support both peripheral and subarea nodes.

```

*****
* NCP/TOKEN RING INTERCONNECT - PHYSICAL CONNECTIONS *
*****
*
A31NTR1 GROUP ADAPTER=TIC2, *
            ANS=CONTINUE, *
            ECLTYPE=(PHYSICAL,ANY), *
            NPACOLL=(YES,EXTENDED), *
            TRSPEED=4, *
            USSTAB=AUSSTAB, VTAM-only keyword *
            XID=NO
*
A31TR88 LINE ADDRESS=(1088,FULL), Line address in controller chassis *
            LOCADD=400000003131, This TIC's ring-station address *
            MAXTSL=4060, *
            PORTADD=1, User-assigned ID number (0-99) *
            RCVBUFC=32000
*
A31PU88 PU
            .
            .
            .
*

```

Figure 6-6 (Part 1 of 2). Example: Defining Type 2 and Type 3 Token-Ring Physical Connections

```

*****
*          3746 MODEL 900 PHYSICAL CONNECTIONS          *
*****
*
A3137CS  GROUP  ADAPTER=TIC3,                               *
                ANS=CONTINUE,                               *
                ECLTYPE=(PHYSICAL,ANY),                     *
                ISTATUS=ACTIVE,      VTAM-only keyword     *
                TRSPEED=16,                               *
                USSTAB=AUSSTAB,      VTAM-only keyword     *
                XID=NO
*
A31L2144 LINE  ADDRESS=(2144,FULL), Line address in 3746 Model 900 *
                LOCADD=400000007041, This TIC's ring-station address *
                MAXTSL=3500,                               *
                PORTADD=10,      User-assigned ID number (0-99) *
                TRSPEED=16,                               *
                XMONLNK=YES
*
A31P2144 PU    PUTYPE=1          PUTYPE=1 added to GROUP by NDF

```

Figure 6-6 (Part 2 of 2). Example: Defining Type 2 and Type 3 Token-Ring Physical Connections

## Defining Backup Token-Ring Interface Couplers

Sessions lost when a TIC fails can be recovered by swapping the failing TIC with a backup, undefined TIC. You can use an undefined type 2 TIC to back up a type 2 or a type 1 TIC, a type 1 TIC to back up a type 1 TIC, or a type 3 TIC to back up a type 3 TIC. Replace the failed TIC with the backup TIC using the maintenance and operator subsystem (MOSS) console.

When TIC swapping is invoked, NCP changes all required fields in NCP to address the new TIC. For example, suppose you have TICs at addresses 1088, 1089, 1090, and 1091. The TICs at addresses 1088 and 1089 are type 1 TICs and the TICs at addresses 1090 and 1091 are type 2 TICs. In your NCP generation definition, define two physical lines, one with address 1088 and the other with address 1090. Leave addresses 1089 and 1091 undefined. If the TIC at address 1088 fails, you can use the MOSS port swap function to swap the TIC at either address 1089 or address 1091 with it. If you use the TIC at address 1091, the user-defined physical line name, such as LN1088, is now associated with the TIC at address 1091 instead of address 1088. All logical connections defined to be associated with LN1088 are established through the TIC at address 1091. All characteristics defined for the TIC at address 1088 are applied to the TIC at address 1091. Even though address 1091 is a type 2 TIC, it functions as a type 1 TIC.

**Note:** No additional coding is required to swap a type 3 TIC because type 3 TIC control blocks are compatible.

Code the following definition statement and keyword to provide NCP with information about the compatibility of NCP control blocks. Code this only to define a backup TIC for a NTRI connection (a type 1 or type 2 TIC).

```

GROUP          COMPSWP

```

## Defining Token-Ring Physical Connections

COMPSWP on the GROUP definition statement specifies whether the control block structure for IBM special products or user-written code is compatible with the NCP control block structure for TIC swapping. If you omit COMPSWP, NDF adds COMPSWP=YES to the GROUP definition statement.

## Duplicate TIC Addressing

You can define two or more physical lines in an NCP or in different NCPs in the same LAN, with the same TIC address, using the LOCADD keyword. This is called *duplicate TIC addressing*. For NCP V7R4 and earlier releases, TICs with duplicate addresses can support only peripheral traffic. Starting in NCP V7R5, TICs with duplicate addresses can concurrently support peripheral traffic, subarea traffic, and frame-relay traffic. However, only one of the physical lines with the duplicate MAC address can support frame-relay traffic.

**Note:** TICs with the same address cannot be activated at the same time on the same ring segment.

### Duplicate TIC Addressing for Logical Peripheral Connections

As noted earlier, you can define two or more physical lines in an NCP (or in different NCPs on the same LAN) with the same TIC address, on the LOCADD keyword. In a peripheral environment, this enables an attaching peripheral device to use a single TIC address even though more than one physical line (TIC) might be available.

**Note:** If one of the duplicate TICs is a NTRI resource and the other is a 3746 Model 900 resource, they can both have the same LOCADD value, but they must have different PORTADD values.

It is important to configure your network so that traffic for a logical peripheral connection does not pass across multiple Token-Rings with each ring having an attached TIC with the same Token-Ring address. In Figure 6-7 on page 6-17, the path from one of the user-access Token-Ring networks to NCP through the connection made using line 1088 does not pass through Token-Ring backbone B; the path from one of the user-access Token-Ring networks to NCP through the connection made using line 1089 does not pass through Token-Ring backbone A. If the path used for a logical connection from one TIC passes across a ring with a TIC sharing the same address, both TICs will copy frames initiated from the peripheral device resulting in unpredictable results.

**Establishing Logical Peripheral Connections:** The TIC used for a peripheral connection is assigned when the connection is established. Thereafter, all data traffic for the peripheral connection goes through that TIC. Incoming connections are established through the TIC selected by the initiating device. The device usually selects that TIC that first responds successfully to the connection request. Outgoing connections are established through the TIC selected by the port address coded in the dial digits on the VTAM PATH statement. When physical lines (TICs) have different PORTADD values, VTAM establishes an outgoing connection through the TIC by the passed dial digits. See Figure 6-8 on page 6-18 for an illustration of different PORTADD values for the two lines defined in the example. When the dial digits contain a 01 port address, an outgoing connection is established using line 1088 to token-ring backbone A. When the dial digits contain a 02 port address, an outgoing connection is established using line 1089 to token-ring backbone B.

**Load Balancing:** When duplicate TICs have the same PORTADD value, NCP balances outgoing calls by alternating between the duplicate ports. By distributing the connections across the duplicate ports, the traffic load for the peripheral connections is better balanced. For incoming logical peripheral connections in an environment with many devices, distribution tends to be statistically balanced. In an environment where there are few devices, statistical load balancing is less likely.

Starting in NCP V7R6, connection balancing allows you to distribute incoming call requests across all associated duplicate TICs. See page the description of the BALANCE keyword on page 6-8 for more details. By balancing the actual peripheral connections, the associated traffic load is more balanced across the duplicate ports. To achieve an approximate symmetrical distribution, you should specify the same balancing factor for all of the duplicate TICs. However, defining differing values may result in a weighted connection distribution depending upon your network configuration.

**Sample Definition of Duplicate TIC Addresses for Logical Peripheral Connections:** Figure 6-7 shows two physical Token-Ring lines defined with the same local Token-Ring address. Each line is attached to a separate backbone Token Ring. Duplicate lines increase the availability of NCP to the attached user-access Token-Ring networks for Token-Ring logical peripheral connections. If either backbone Token Ring fails, the other is able to provide connections between NCP and all the user-access Token-Ring networks.

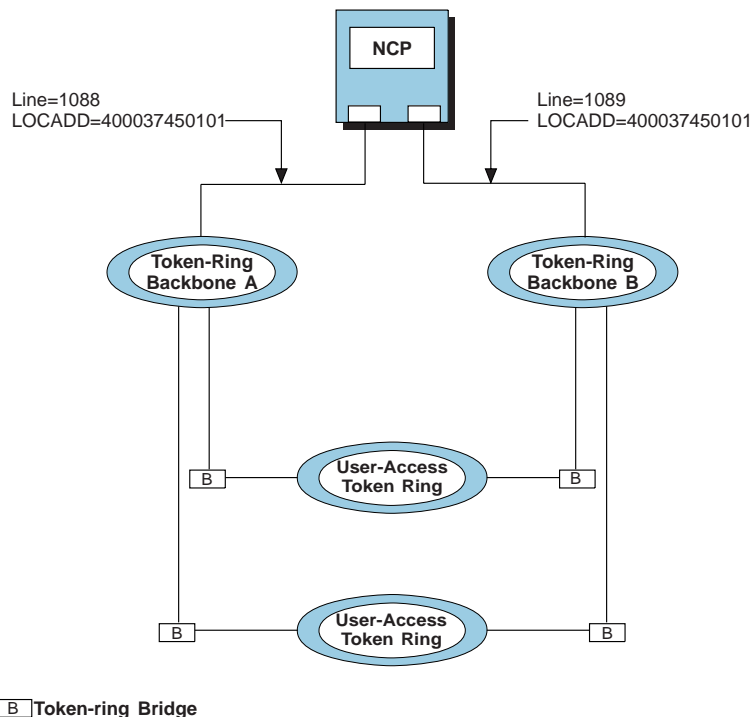

Figure 6-7. Duplicate TIC Configuration for Logical Peripheral Connections

Figure 6-8 on page 6-18 shows how to define the duplicate TICs with different port addresses shown in Figure 6-7.

## Defining Token-Ring Physical Connections

```
TRPG1  GROUP  ECLTYPE=(PHY,PER),  NTRI physical connections
        ADAPTER=TIC2,
        TRSPEED=16
*
TRPL1  LINE  ADDRESS=(1088,FULL), Line address in controller
        PORTADD=01,           User-assigned ID number (0-99)
        LOCADD=400037450101, This TIC's ring-station address
        BALANCE=1             Balancing factor
TRPU1  PU
*
TRPL2  LINE  ADDRESS=(1089,FULL), Line address in controller
        PORTADD=02,           User-assigned ID number (0-99)
        LOCADD=400037450101, This TIC's ring-station address
        BALANCE=1             Balancing factor
TRPU2  PU
*
TRLG1  GROUP  ECLTYPE=(LOG,PER),  NTRI peripheral logical lines
        PHYPORT=NONE,        Not associated with physical line
        CALL=INOUT,
        AUTOGEN=60           Adds 60 LINE and PU pairs
```

Figure 6-8. Example: Defining a Duplicate TIC Configuration for Logical Peripheral Connections

### Duplicate TIC Addressing for Logical Subarea Connections

For NCP V7R4 and earlier releases, TICs with the same MAC address cannot support subarea traffic because of the point-to-point restriction for logical subarea connections between TICs. Starting in NCP V7R5, this restriction does not apply because TICs with the same address can support subarea traffic.

Although the advantages of using duplicate TICs for load balancing and backup do not apply to subarea connections like they do to peripheral connections, this support does allow you to use a TIC with a duplicate MAC address for subarea connectivity. See the SSAP keyword on page 6-31 and the UNIQUE keyword on page 6-32 for more information.

#### **Sample Definition of Duplicate TIC Addresses for Logical Subarea Connections:**

Figure 6-9 on page 6-19 shows two physical Token-Ring lines defined with the same local Token-Ring address. Each line is attached to a separate backbone Token Ring with line 1088 having a logical subarea connection to NCP2.

## Defining Token-Ring Physical Connections

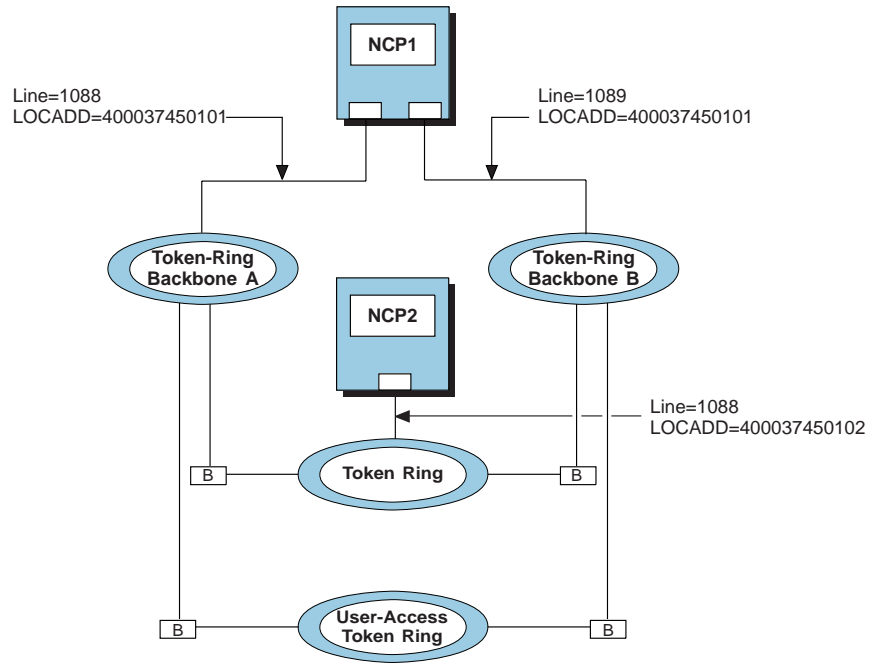

**B** Token-ring Bridge

Figure 6-9. Duplicate TIC Configuration for Logical Subarea Connections

Figure 6-10 on page 6-20 shows how to define the duplicate TICs with different port addresses for NCP1 as shown in Figure 6-9.

## Defining Token-Ring Logical Connections

```
        BUILD VERSION=V7R8,  
        .  
        .  
*  
TRPG1  GROUP ECLTYPE=(PHY,ANY), NTRI physical connections  
        ADAPTER=TIC2,  
        TRSPEED=16  
*  
TRPL1  LINE ADDRESS=(1088,FULL), Line address in controller  
        PORTADD=01,           User-assigned ID number (0-99)  
        LOCADD=400037450101 This TIC's ring-station address  
*  
TRPU1  PU  
*  
TRPL2  LINE ADDRESS=(1089,FULL), Line address in controller  
        PORTADD=02,           User-assigned ID number (0-99)  
        LOCADD=400037450101 This TIC's ring-station address  
*  
TRPU2  PU  
*  
TRLG1  GROUP ECLTYPE=(LOGICAL,SUBAREA), NTRI subarea logical lines  
        PHYPORT=1,  
        SDLCST=(,TRPRIM)  
*  
TRLLN1 LINE MLTGPRI=60,  
        TGN=1  
*  
TPLPU1 PU  ADDR=08400037450102,  
        SSAP=0C,  
        MAXDATA=5000
```

Figure 6-10. Example: Defining a Duplicate TIC Configuration for Logical Subarea Connections

### Duplicate TIC Addressing for NTRI Frame Handler Logical Connections

For NCP V7R4 and earlier releases, TICs with the same MAC address cannot support frame relay traffic because of the point-to-point restriction for frame handler logical connections between TICs. Starting in NCP V7R5, this restriction does not apply because TICs with the same address can support frame-relay traffic. However, only one of the physical lines with the duplicate MAC address can support frame-relay traffic. As for subarea traffic, there is no real advantage to duplicate TIC addressing for frame-relay traffic except to use an existing duplicate TIC.

---

## Defining Token-Ring Logical Connections

Define at least one logical line group to connect Token-Ring network devices to NCP. There are three types of logical connections. Logical peripheral connections between NCP and a peripheral node (a type 2 or type 2.1 physical unit) are defined as switched, half-duplex lines. Logical subarea connections between NCP and a subarea node (a type 4 or type 5 physical unit) are defined as nonswitched, half-duplex lines. Refer to "Defining Token-Ring Logical Subarea Connections" on page 6-29 for more information about defining logical subarea lines. NTRI frame handler logical connections between two NCPs (type 1 physical units) are defined



as nonswitched, half-duplex lines. See “Defining NTRI Frame Handler Logical Links” on page 16-66 for more information.

These logical connections depend on network topology:

- Local logical connections are connections between stations on the same Token Ring.
- Remote logical connections are connections between stations on different Token Rings using bridges between the Token Rings.

You can define a total of 9999 logical lines used in association with a Token-Ring or frame-relay physical connection. There is processing and storage overhead associated with each defined logical line, so do not define more logical lines than you will need at one time.

The definition statements for each logical Token-Ring line group must follow the definition of the corresponding physical Token-Ring line group in your system generation definition. If you want to define a Token-Ring subarea link, see “Defining Token-Ring Logical Subarea Connections” on page 6-29 for more information.

Code the following definition statements and keywords to provide NCP with information about the types of resources, and how to improve performance and recover from errors.

BUILD	LOCALTO NAMTAB OWNERPL <sup>2</sup> REMOTTO T1TIMER <sup>1</sup> T2TIMER
LUDRPOOL	NUMTYP2
GROUP	AUTOGEN ECLTYPE PHYPORT PHYSRSC RNRLIMT
LINE	CALL NPACOLL RETRIES
PU	ANS NPACOLL
<sup>1</sup> Supported starting with NCP V7R3. <sup>2</sup> Supported starting with NCP V7R6.	

### BUILD

LOCALTO, REMOTTO, T1TIMER, and T2TIMER on the BUILD definition statement define timeout values for logical connections. Starting with NCP V7R3, you can

## Defining Token-Ring Logical Connections

replace the LOCALTO and REMOTTO keywords with the T1TIMER keyword to specify the reply timer value. See “Timers for Logical Connections” on page 6-44 for more information about timer values.

NAMTAB on the BUILD definition statement specifies how many entries the network names table is to contain. For an Advanced Peer-to-Peer Networking (APPN) network, the value for NAMTAB must be large enough to allow multiple and parallel sessions among independent logical units.

OWNERPL on the BUILD definition statement specifies whether unassigned logical Token-Ring resources will be managed in owner-based pools. See “Unassigned Logical Line Pools” on page 6-24 for more information.

### LUDRPOOL

NUMTYP2 on the LUDRPOOL definition statement specifies the number of logical unit control blocks (LUBs) included in the LUB pool that can be used to communicate with logical units associated with a Token-Ring logical connection.

### GROUP

AUTOGEN on the GROUP definition statement defines the number of LINE and PU definition statement pairs to be automatically added to the logical GROUP definition statement. AUTOGEN is valid only when you define logical peripheral lines. For an alternative to AUTOGEN, see “Autocopy Function” on page 2-12.

ECLTYPE defines a group of logical connections to an IBM Token-Ring Network. The corresponding GROUP definition for the physical line group must contain one of the following:

- ECLTYPE=(PHYSICAL,SUBAREA or PHYSICAL,ANY) if you code ECLTYPE=(LOGICAL,SUBAREA) for this line group.
- ECLTYPE=(PHYSICAL,PERIPHERAL or PHYSICAL,ANY) if you code ECLTYPE=(LOGICAL,PERIPHERAL) for this line group.
- ECLTYPE=(PHYSICAL,SUBAREA or PHYSICAL,PERIPHERAL or PHYSICAL,ANY) if you code ECLTYPE=(LOGICAL,FRELAY) for this line group.

PHYPORT defines the port address for a group of logical lines. You can associate a group of Token-Ring logical lines with one or more physical lines if the PHYPORT value matches the PORTADD value coded on the physical line definition(s). Code PHYPORT=NONE for NTRI logical peripheral lines if you want them to remain unassigned until the logical connection is made. Code PHYPORT=(NONE,ODLC) to create an unassigned logical line pool for 3746 Model 900 Token-Ring physical connections. Code the PHYPORT keyword only when you define peripheral connections or NTRI subarea connections. See “Unassigned Logical Line Pools” on page 6-24 for more information.

PHYSRSC associates a group of Token-Ring logical lines with a physical line if the value coded on PHYSRSC matches the label assigned to the PU definition statement. For subarea resources, PHYSRSC has the advantage of causing VTAM to defer activation of logical lines associated with a physical station until the station is activated. Code PHYSRSC=NONE for NTRI logical peripheral lines if you want them to be unassigned until the time the logical connection is made. Code PHYSRSC=(NONE,TIC3) or PHYSRSC=(NONE,ODLC) to create an unassigned logical line pool for 3746 Model 900 Token-Ring physical connections. See “Unassigned Logical Line Pools” on page 6-24 for more information.

For NTRI frame handler logical lines, the value coded on PHYRSC must match the PU defined with NETWORK=FRELAY on the physical line.

**Note:** You can code either PHYPORT or PHYRSC to associate a group of Token-Ring logical lines with a physical line. PHYRSC is recommended because it associates logical resources with physical resources for any type of Token-Ring connection. PHYPORT is not valid for:

- NTRI frame handler logical lines.
- 3746 Model 900 Token-Ring subarea connections
- 3746 Model 900 Token-Ring peripheral connections prior to NCP V7R8

RNRLIMIT specifies how long a station has to reject data before NCP identifies the station as inoperative. A station is considered inoperative if it responds with only receive-not-ready (RNR) frames to data or polls sent by NCP during the interval defined by RNRLIMIT.

### LINE

CALL on the LINE definition statement specifies whether the line is for incoming calls, outgoing calls, or both.

**NTRI:** NPACOLL specifies whether the Token-Ring logical line is eligible for performance data collection through NPM.

RETRIES on the LINE definition statement specifies how many attempts NCP is to make to recover from errors that occur during transmission over a Token-Ring logical line. See “Logical Line Retries” on page 6-47 for additional information.

### PU

ANS on the PU definition statement specifies whether the Token-Ring logical line continues operating if your NCP enters automatic network shutdown. For peripheral lines, the ANS value in the NCP generation definition is overridden by the ANS value in the VTAM switched major node definition.

**3746 Model 900 Token Ring:** NPACOLL on the PU definition statement specifies whether the Token-Ring link station is eligible for performance data collection through NPM. Code NPACOLL=(YES,EXT) to collect performance data.

### Sample Definition of Token-Ring Logical Connections

Figure 6-11 shows an example of two Token-Ring logical connections associated with the physical connections shown in Figure 6-5 on page 6-14.

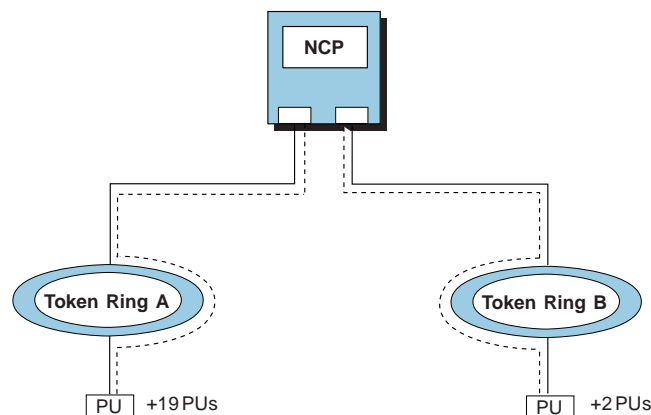

Figure 6-11. Token-Ring Logical Connections

## Defining Token-Ring Logical Connections

Figure 6-12 on page 6-24 shows how to define the Token-Ring logical connections shown in Figure 6-11. Both line groups are for peripheral nodes. The peripheral line group for Token Ring A supports 20 peripheral nodes. The peripheral line group for Token Ring B supports three peripheral nodes. You associate these peripheral nodes with the physical line by coding the symbol A31P2144 on the physical PU definition statement and the PHYSRSC keyword on the logical GROUP definition. See "Sample Definition for Token-Ring Logical Subarea Connections" on page 6-32 for an example of how to code a logical line group for subarea nodes.

```
*****
* NTRI PERIPHERAL LOGICAL LINES - GENERATED IN NEWDEFN          *
*                                     USED WITH A31TR88 AND/OR A31TR89 *
*****
*
A31BNNG1 GROUP ANS=CONTINUE,                                     *
                AUTOGEN=20,           Adds 20 LINE and PU pairs  *
                CALL=INOUT,           *
                ECLTYPE=LOGICAL,      *
                ISTATUS=ACTIVE,       VTAM-only keyword          *
                MODETAB=AMODETAB,     VTAM-only keyword          *
                NPACOLL=(YES,EXTENDED), *
                PHYSPORT=NONE,        Not associated with physical line *
                RETRIES=(10,10,10,10), *
                USSTAB=AUSSTAB,       VTAM-only keyword          *
                XMITDLY=NONE
*
*
*
*****
*          3746 MODEL 900 PERIPHERAL LOGICAL LINES              *
*****
*
A31BNNG2 GROUP ANS=CONTINUE,                                     *
                AUTOGEN=3,           Adds 3 LINE and PU pairs  *
                CALL=INOUT,           *
                ECLTYPE=(LOGICAL,PER), *
                ISTATUS=ACTIVE,       VTAM-only keyword          *
                MODETAB=AMODETAB,     VTAM-only keyword          *
                PHYSRSC=A31P2144,     Associate logical with physical *
                RETRIES=(3,2,1),      *
                USSTAB=AUSSTAB       VTAM-only keyword          *
```

Figure 6-12. Example: Defining a Token-Ring Logical Connection

## Unassigned Logical Line Pools

In certain environments, it can be advantageous to define a pool of logical peripheral lines that are not assigned to physical lines but are assigned as needed. Call-in connections on peripheral lines use assigned logical lines before using the unassigned logical lines.

NTRI and 3746 Model 900 connections have separate unassigned logical line pools. Code PHYSRSC=NONE or PHYSPORT=NONE on the GROUP definition statement to define an unassigned logical line pool for NTRI. Code PHYSRSC=(NONE,TIC3), PHYSRSC=(NONE,ODLC), or

PHYPORT=(NONE,ODLC)<sup>1</sup> on the GROUP definition statement to define an unassigned logical line pool for 3746 Model 900 Token-Ring lines.

### Allocating Unassigned Logical Line Pools to Owners

In a multiple-owner environment (for example, dual CMCs), it might be advantageous to have multiple unassigned logical line pools that are based on the owning SSCP. To do this, you must:

1. Allocate each physical line to a specific owner by coding the VTAM-only OWNER keyword for each physical line with one and only one *owner\_name*.
2. Allocate each logical pool to a specific owner by coding the VTAM-only OWNER keyword for each logical pool.
3. Code the OWNERPL keyword on the BUILD statement.

This function will control call-in connections. An unassigned logical resource will be used for an incoming call only if the logical resource has the same owning SSCP as the physical line over which the call was made. If there are no logical resources available with the same owning SSCP, an incoming call cannot be established. Even when this function is genned, assigned logical lines continue to be used before the unassigned logical lines.

To create the owner-based unassigned logical pools for NTRI resources, code TR on OWNERPL. To create the owner-based unassigned logical pools for 3746 Model 900 Token-Ring resources, code ODLCTR on OWNERPL.

## Defining Peripheral Device Addresses for VTAM

When you are defining a switched major node to VTAM that uses a Token-Ring logical peripheral line, if the connection to the Token-Ring device will be initiated by VTAM, you need to specify dial information to enable VTAM to initiate the connection. There are two ways to do this:

- For VTAM V4R1 and earlier, code the VTAM DIALNO keyword on the VTAM PATH definition statement. For more information, refer to the description of DIALNO for the switched major node definition in *VTAM Resource Definition Reference*.
- For VTAM V4R2 or later, you can code the VTAM DIALNO keyword or the VTAM DLCADDR keyword on the VTAM PATH definition statement. The remainder of this section describes how to code the VTAM DLCADDR keyword.

A Token-Ring DLC address has these elements. Code one DLCADDR keyword for each element.

1. DLC type
2. Port number
3. Destination service access point (DSAP)
4. Destination's medium access control (MAC) address
5. Source service access point (SSAP) (optional)

In the DLCADDR keyword value:

- The first suboperand indicates which element you are defining.

<sup>1</sup> Starting with NCP V7R8.

## Sample Token-Ring Peripheral Resource Definitions

- The second suboperand indicates the format of the third suboperand (C=character, D=decimal, and X=hexadecimal).
- The third suboperand defines the value of the element.

Code the DLCADDR keyword as follows:

1. To specify a DLC type of Token Ring, code:

```
DLCADDR=(1,C,TR)
```

2. To identify the port number of the Token-Ring physical line, code:

```
DLCADDR=(2,D,nn)
```

where *nn* is the decimal number corresponding to the value you code for PORTADD on the LINE definition statement.

3. To specify the DSAP, code:

```
DLCADDR=(3,D,nn)    or    DLCADDR=(3,X,hh)
```

where *nn* and *hh* are the SAP of the remote Token-Ring station, in decimal and hexadecimal, respectively.

4. To specify the destination's medium access control (MAC) address, code:

```
DLCADDR=(4,X,hhhhhhhhhhhh)
```

where *hhhhhhhhhhhh* is the hexadecimal MAC address of the remote Token-Ring station.

5. To specify the SSAP, code:

```
DLCADDR=(5,D,nn)    or    DLCADDR=(5,X,hh)
```

where *nn* and *hh* are the SAP of the source NCP, in decimal and hexadecimal, respectively. If you choose to specify the SSAP, you must specify a SAP of 04 for NCP dial processing.

For example, suppose you need to make outgoing connections to an adjacent peripheral device attached to a Token Ring with a MAC address of X'400012345678' and a SAP of 4, and NCP is attached to the Token Ring through port number 10. To specify this information using the DLCADDR keyword, code:

```
DLCADDR=(1,C,TR),           A Token-Ring switched connection
DLCADDR=(2,D,10),          Using NCP Token-Ring port 10
DLCADDR=(3,D,4),           Peripheral device DSAP
DLCADDR=(4,X,400012345678) Peripheral device MAC address
```

For more information on the VTAM PATH definition statement and DLCADDR keyword, refer to *VTAM Resource Definition Reference*.

---

## Sample Token-Ring Peripheral Resource Definitions

Figure 6-13 on page 6-27 shows how to define Token-Ring peripheral resources. This example includes a pool of 40 unassigned logical peripheral lines.

NDF adds some of these definition statements and keywords automatically. For more information, see "NDF-Generated Additions for Token-Ring Resources" on page 6-4.

```

BNAME    BUILD T2TIMER=(0.2,0.3,2)
*
PERGRP   GROUP ECLTYPE=(PHYSICAL,PERIPHERAL)
*
PERLN1   LINE  ADDRESS=(1088,FULL),      Line addr in controller chassis
          LOCADD=400037450101,       This TIC's ring-station address
          PORTADD=1                   User-assigned ID number (0-99)
*
PERPU1   PU
*
PERLN2   LINE  ADDRESS=(1089,FULL),      Line addr in controller chassis
          LOCADD=400037450102,       This TIC's ring-station address
          LSPRI=PU,                   Prioritize PU sessions
          PORTADD=2                   User-assigned ID number (0-99)
*
PERPU2   PU
*
          .
          .                               Other physical LINE and PU
          .                               pairs
*
LPERGR1  GROUP ECLTYPE=(LOGICAL,PERIPHERAL),
          PHYSRSC=NONE,               Not assigned
          CALL=INOUT,                 NCP or devices can initiate
          AUTOGEN=40                  Adds 40 LINE and PU pairs
*
LPERGR2  GROUP ECLTYPE=(LOGICAL,PERIPHERAL),
          PHYSRSC=PERPU1              Associate logical resource with PU
*
LPERLN2  LINE  CALL=INOUT              NCP or devices can initiate
*
LPERPU2  PU
*
LPERGR3  GROUP ECLTYPE=LOGICAL,        This is a peripheral group
          PHYSRSC=PERPU2,             Refers to line group name
          CALL=INOUT,                 NCP or devices can initiate
          AUTOGEN=24                  Adds 24 LINE and PU pairs
*
          .
          .
          .                               Logical GROUPS for other
          .                               physical lines
    
```

Figure 6-13. Example: Defining NTRI with Peripheral Lines

## Token-Ring Subarea Links

This section describes general requirements for defining Token-Ring physical and logical connections to an adjacent subarea.

A connection between subareas is a transmission group. You can assign up to 255 SDLC, Token-Ring, and frame-relay lines in any combination to the same transmission group. See "Transmission Groups" on page 12-15 for more information.

A type 1 TIC supports either peripheral or subarea nodes, but not both. A type 2 or type 3 TIC supports any combination of subarea and peripheral nodes in the same Token Ring. If the ring has a mix of peripheral and subarea nodes, and only type 1 TICs are available, define at least two physical lines, one for peripheral con-

## Token-Ring Subarea Links

nections and one for subarea connections. Each physical line definition requires a corresponding logical line definition.

Figure 6-14 shows physical and logical lines in a Token-Ring subarea link.

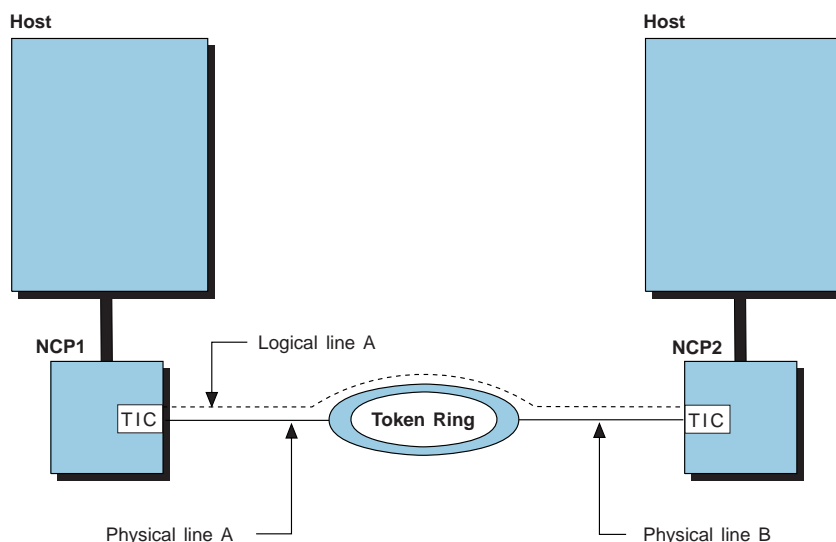

Figure 6-14. Token-Ring Subarea Physical and Logical Lines

## Defining Token-Ring Physical Subarea Connections

Define at least one physical line group to connect the communication controller to the Token-Ring network. The physical connection of NCP to the Token Ring is a nonswitched duplex line. “Defining Token-Ring Physical Connections” on page 6-6 describes the general requirements for defining Token-Ring physical lines.

Code the following definition statement and keywords to provide NCP with information about the type of subarea connection.

GROUP	ECLTYPE
-------	---------

ECLTYPE defines the type of Token-Ring resources that are defined by the line group:

- ECLTYPE=(PHYSICAL,SUBAREA) defines a physical line group that supports only subarea connections.
- ECLTYPE=(PHYSICAL,ANY) defines a physical line group that can support subarea connections, peripheral connections, or a combination of both types of nodes on the same TIC. ANY is valid on ECLTYPE only when ADAPTER=TIC2 or ADAPTER=TIC3.



### Sample Definition of Token-Ring Physical Subarea Connections

Figure 6-15 shows how to code a Token-Ring physical connection to a subarea. The physical connection also supports logical connections to peripheral nodes.

```

A3137CS GROUP ADAPTER=TIC3, *
              ANS=CONTINUE, *
              ECLTYPE=(PHYSICAL,ANY), *
              ISTATUS=ACTIVE, VTAM-only keyword *
              TRSPEED=16, *
              USSTAB=AUSSTAB, VTAM-only keyword *
              XID=NO
*
A31L2144 LINE ADDRESS=(2144,FULL), Line address in 3746 Model 900 *
              LOCADD=400000007041, This TIC's ring-station address *
              MAXTSL=3500, *
              PORTADD=10, User-assigned ID number (0-99) *
              TRSPEED=16, *
              XMONLNK=YES
*
A31P2144 PU PUTYPE=1 PUTYPE=1 added to GROUP by NDF

```

Figure 6-15. Example: Defining Token-Ring Physical Subarea Connections

### Defining Token-Ring Logical Subarea Connections

You can define more than one logical subarea connection between NCPs across a Token Ring. However, for NCP V7R4 and earlier releases, only one logical subarea connection can be activated between two NCPs if each NCP uses a single physical connection to the Token Ring. This restriction does not apply to NCPs running V7R5 or later releases; however, if type-3 TICs are used, they must have the appropriate TRP microcode level (EC D46120).

The logical subarea connection is made between the TICs at either end of the connection by using the address of each TIC. You can assign more than one Token-Ring logical subarea link to a single transmission group if each link is associated with a unique pair of TIC addresses and service access points (SAPs).

Code the following definition statements and keywords to provide NCP with information about the subarea identification, transmission characteristics, and how to improve performance.

## Token-Ring Subarea Links

GROUP	ECLTYPE NETID PHYPORT PHYSRSC
LINE	IPL LOCALTO MLTGPRI MONLINK REMOTTO RETRIES SDLCST T1TIMER T2TIMER
PU	ADDR SSAP <sup>1</sup> MAXDATA MAXOUT NETID PIUCHECK <sup>3</sup> TGCONF TGN UNIQUE <sup>2</sup>

<sup>1</sup> Supported starting with NCP V7R5.  
<sup>2</sup> Supported starting with NCP V7R6.  
<sup>3</sup> Supported starting with NCP V7R7.

### GROUP

ECLTYPE on the GROUP definition statement defines a logical subarea link. The corresponding GROUP definition for the physical line group must contain ECLTYPE=(PHYSICAL,SUBAREA) or ECLTYPE=(PHYSICAL,ANY) if you code ECLTYPE=(LOGICAL,SUBAREA) for this line group.

NETID identifies the name of the non-native subarea network. The *name* suboperand is the NETID value on the NETWORK definition statement for the non-native network. If you code the second suboperand, ANY, NETID values on the PU definition statements for this group do not have to be the same.

PHYPORT defines the port address for a group of logical lines, and it associates a group of Token-Ring logical lines with a physical line if it matches the PORTADD value coded on the physical line definition.

#### Notes:

1. When PHYPORT defines the port address for a group of Token-Ring logical lines and when multiple physical lines are defined with a matching PORTADD value, the group of logical lines will be associated with the first physical line defined with that PORTADD value.
2. Code the PHYPORT keyword only when you define NTRI connections.

PHYSRSC associates a group of Token-Ring logical lines with a physical line if the value coded on PHYSRSC matches the label assigned to the PU definition statement. For NTRI, you can code either PHYPORT or PHYSRSC to associate SNA logical lines with a physical connection. PHYSRSC has the advantage of causing VTAM to defer activation of logical subarea lines associated with a physical station until the station is activated. Code SUBAREA or ANY on ECLTYPE to define the corresponding physical line. If you choose PHYPORT, code the same value on both PHYPORT and PORTADD in the LINE definition statement that defines the physical connection.

## LINE

IPL on the LINE definition statement specifies whether your NCP can be loaded or dumped over this link. Code IPL=YES to load a remote NCP over a Token-Ring subarea link. See “Remote Loading and Activation over a Token-Ring Line” on page 6-48 for more information.

LOCALTO, REMOTTO, T1TIMER, and T2TIMER define timeout values used for logical connections. Starting with NCP V7R3, you can replace the LOCALTO and REMOTTO keywords with the T1TIMER keyword to specify the reply timer value. See “Determining a T1 (Reply) Timer Value for a Local Link” on page 16-36 for more information about determining a value for the T1TIMER keyword.

MLTGPR1 assigns a priority value to a line in an MLTG. Code MLTGPR1 when you define a Token-Ring line that is activated in an MLTG. See “Multilink Transmission Groups” on page 12-16 for more information.

MONLINK specifies that SMMF is to activate and monitor subarea links. You can code MONLINK=YES, NO, or CONTINUOUS. Code MONLINK=YES on at least one subarea line, channel link, channel link station, or ESCON logical line definition to allow NCP activation following a load.

RETRIES specifies how many attempts NCP is to make to recover from errors that occur during transmission over a Token-Ring logical line. See “Logical Line Retries” on page 6-47 for additional information.

SDLCST identifies the names of the SDLCST definition statements used for this logical subarea line. SDLCST definition statements provide subarea link characteristics used by NCP when the link station is operating in either primary or secondary mode. See “Defining SDLC Subarea Links” on page 12-3 for more information about how to code SDLCST statements.

## PU

ADDR on the PU definition statement identifies the destination service access point (DSAP) and hardware address of the Token-Ring connection to a session partner. The value you code carries the DSAP first and the hardware address last. Only a DSAP of X'04' is supported for subarea connections to an adjacent NCP running V7R4 or an earlier release. This restriction does not apply beginning with NCP V7R5; however, if the hardware address is for an adjacent TIC3, it must have the appropriate microcode level.

**Note:** LOCADD on the physical line GROUP definition specifies the local TIC hardware address for the adjacent NCP; ADDR identifies the DSAP and hardware address of the session partner TIC.

SSAP specifies the source service access point (SSAP) for this Token Ring subarea connection. A Token Ring station's address comprises the local and

## Token-Ring Subarea Links

remote MAC addresses and the source and destination SAPs. The SSAP keyword and the DSAP portion of the ADDR keyword enable you to specify multiple logical subarea stations with unique addresses to TICs that have the same MAC address.

**Note:** Using the default SSAP of X'04' works in most configurations. However, if you want to have multiple logical subarea connections from one TIC to another TIC or TICs with the same MAC address, you must use different SSAPs to obtain unique addressing.

MAXDATA minimizes the coordination problems among different line types by limiting the maximum amount of data the link station can receive in one data transfer. Code MAXDATA only if the Token-Ring subarea link is part of an MLTG. The limit you specify includes one PIU or PIU segment and header information. Refer to the documentation for a specific device to determine how much data it can receive. See "Multilink Transmission Groups" on page 12-16 for more information.

MAXOUT determines the number of frames that NCP is to send before receiving an acknowledgment. Code MAXOUT on the PU definition statement only for subarea lines. See "Window Sizes for Sending and Receiving Frames" on page 6-42 for more details on how to use MAXOUT.

NETID identifies the network containing the adjacent subarea node. Code the same NETID value on each PU definition statement in each group, unless you code NETID=(*name*,ANY) on the GROUP definition statement.

PIUCHECK specifies whether a checksum validation should be performed on PIUs sent and received by this station. For the checksum validation support to be enabled, the adjacent link station must also have PIUCHECK=YES coded. For more information about the PIUCHECK subarea checksum support, see PIUCHECK keyword on the PU definition statement on page 24-9.

TGCONF specifies whether a transmission group contains one or more logical lines. Code TGCONF=SINGLE if transmission group contains only a single Token-Ring logical subarea line.

TGN assigns the logical link to a specific transmission group. For more information, see "Transmission Groups" on page 12-15.

UNIQUE indicates the uniqueness of the destination hardware address defined for the ADDR keyword. When the destination hardware address is a unique locally administered address, code UNIQUE=YES to prompt a test frame with a zero (DSAP) value to be sent during route discovery processing. However, when the destination hardware is a duplicate locally administered address, **you must** code UNIQUE=NO prompting a test frame with the DSAP value, specified for the ADDR keyword, to be sent during route discovery processing.

### Sample Definition for Token-Ring Logical Subarea Connections

Figure 6-16 on page 6-33 shows an example of a Token-Ring logical subarea connection.

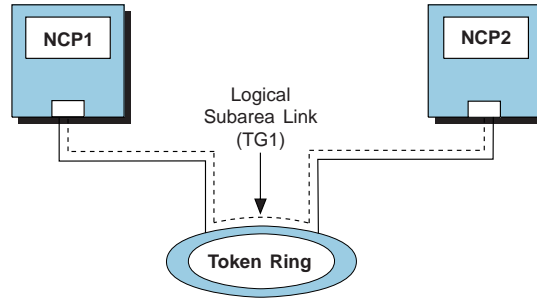

Figure 6-16. Token-Ring Logical Subarea Connections

Figure 6-17 shows how to define the NCP1 Token-Ring logical subarea connection shown in Figure 6-16. This is a logical connection associated with the physical connections defined in Figure 6-15 on page 6-29. The ring station address of the Token-Ring adapter for NCP2 is 400000000431 and the logical subarea connection is assigned to transmission group 1.

```

A31INNG3 GROUP ANS=CONTINUE, *
                ECLTYPE=(LOGICAL,SUBAREA), *
                IPL=YES, *
                ISTATUS=ACTIVE, VTAM-only keyword *
                MAXOUT=3, *
                MODETAB=AMODETAB, VTAM-only keyword *
                MONLINK=YES, *
                PHYSRSC=A31P2144, Associate logical with physical *
                RETRIES=(3,2,1), *
                SDLCST=(,N31SEC), *
                TGCONF=MULTI, *
                USSTAB=AUSSTAB VTAM-only keyword *
*
A31LG2C LINE MLTGPRI=60, *
           TGN=1
*
A31PG2C PU ADDR=04400000000431, *
           MAXDATA=5000
    
```

Figure 6-17. Example: Defining Token-Ring Logical Subarea Connections

## Differences between Subarea and Peripheral Logical Connections

Table 6-1 summarizes how logical subarea lines differ from logical peripheral lines.

Table 6-1 (Page 1 of 2). Token-Ring Logical Subarea and Peripheral Connections

Differences	Logical Subarea Connections	Logical Peripheral Connections
Line type	Nonswitched line	Switched line
PU type	PU type 4	PU type 2 or 2.1
PIU type	FID4 and FIDF PIUs	FID2 PIUs
Logical line assignment	Assign all logical lines to physical lines in the NCP generation definition.	You can define unassigned logical lines.

Table 6-1 (Page 2 of 2). Token-Ring Logical Subarea and Peripheral Connections

Differences	Logical Subarea Connections	Logical Peripheral Connections
Link station addresses	Specify the adjacent NCP link station address in the NCP generation definition.	The link station address is specified in the VTAM definition of the switched major node.
Coding MAXOUT	You can code MAXOUT in the NCP generation definition.	MAXOUT is specified in the VTAM definition of the switched major node.
Link station not available	The connection remains in contact-pending state during link establishment if the other link station is not available.	A timeout occurs on a callout if the other link station is not available.
Duplicate TIC addresses	For NCP V7R4 and earlier releases, you cannot use duplicate TIC addresses for physical Token-Ring lines supporting logical subarea connections. This restriction does not apply to NCPs running V7R5 and later; however, the duplicate type 3 TICs must have the appropriate microcode level.	You can use duplicate TIC addresses for physical Token-Ring lines supporting logical peripheral connections.
SAPs	For NCP V7R4 and earlier releases, a default SSAP of X'04' is used for logical subarea connections. Starting with NCP V7R5, you can use an SSAP other than X'04' for logical subarea connections.	You must use an SSAP of X'04' for logical peripheral connections.
Timer values	You can specify separate timer values for each line.	You cannot specify separate timer values for each line because the lines are not assigned to link stations.
Auto network shutdown (ANS)	The default is session continuation.	The default is session discontinuation.

## 3746 Model 900 Service Processor LAN

The Service Processor LAN is used for MOSS communication on a 3745-xxA, and for MOSS-E communication on a 3746 Model 900 attachment. This LAN can also carry user traffic with the following restrictions:

- All stations on the Service Processor LAN must be configured at 16 Mbps. Code TRSPEED=16 on the physical lines for these stations.
- User stations on the LAN must have hardware addresses (LOCADD) that are different from the following device hardware addresses:
  - The IBM PS/2 that functions as the MOSS-E console
  - The MOSS port on the 3745-xxA
  - The type 3 TIC on the control bus and service processor (CBSP) with line address 2080.

**Note:** These addresses are determined by your IBM support representative at installation time. See *Service Processor Installation and Maintenance* for more information about the Service Processor LAN.

- It is necessary to define a physical line with ADDRESS=2080 and a LOCADD value equal to the hardware address (determined at installation time) of the type 3 TIC on the CBSP with line address 2080.

---

### Converting Existing Token-Ring Resources to 3746 Model 900 Token-Ring Resources

You can attach a Token-Ring to NCP through the 3746 Model 900 (CSS) and type 3 TIC. The 3746 Model 900 improves NCP performance by performing NCP data link control functions. To use the 3746 Model 900, you need to obtain a license for the NCP 3746 Model 900 Feature from IBM.

**Note:** 3746 Model 900 does not support frame handler logical connections.

This section shows how to update your generation definition to convert NTRI lines to 3746 Model 900 Token-Ring lines.

Figure 6-18 on page 6-36 shows the type 2 TIC definition.

# Converting to 3746 Model 900 Token-Ring Resources

```

BUILD VERSION=V7R8,      Generate NCP V7R8      1 *
.
.
.
*
*
*****
*           NTRI PHYSICAL CONNECTIONS           *
*****
*
A31NTRI  GROUP  ANS=CONTINUE,                    *
           ECLTYPE=(PHYSICAL,ANY),              *
           ISTATUS=ACTIVE,      VTAM-only keyword *
           TRSPEED=16,          *
           USSTAB=AUSSTAB,      VTAM-only keyword *
           XID=NO
*
A31L1090 LINE  ADAPTER=TIC2,                    3 *
           ADDRESS=(1090,FULL), Line address in controller 4 *
           LOCADD=400000007041, This TIC's ring-station address *
           MAXTSL=3500,
           PORTADD=10,          User-assigned ID number (0-99) *
           TRSPEED=16,
           XMONLNK=YES
*
A31P1090 PU    PUTYPE=1          PUTYPE=1 added to GROUP by NDF
*
A31L1090 LU    5 *
*
*****
*           NTRI PERIPHERAL LOGICAL LINES       *
*****
*
A31BNG2  GROUP  ANS=CONTINUE,                    *
           AUTOGEN=3,          Adds 3 LINE and PU pairs      *
           CALL=INOUT,
           ECLTYPE=(LOGICAL,PER),
           ISTATUS=ACTIVE,      VTAM-only keyword            *
           MODETAB=AMODETAB,    VTAM-only keyword            *
           PHYPORT=10,          Associate logical with physical *
           RETRIES=(3,2,1),
           USSTAB=AUSSTAB      VTAM-only keyword
*

```

Figure 6-18 (Part 1 of 2). Example: Converting a Type 2 TIC to a Type 3 TIC (Before)



```

*****
* ALLOWS SUBAREA TRAFFIC BETWEEN THE NTRI 1090 LINE AND THE 1088 LINE *
* OF A04NCP. *
*****
*
A31INNG3 GROUP ANS=CONTINUE, *
                ECLTYPE=(LOGICAL,SUBAREA), *
                IPL=YES, *
                ISTATUS=ACTIVE, VTAM-only keyword *
                MAXOUT=3, *
                MODETAB=AMODETAB, VTAM-only keyword *
                MONLINK=YES, *
                PHYPORT=10, Associate logical with physical 6 *
                RETRIES=(3,2,1), *
                SDLCST=(,N31SEC), *
                USSTAB=AUSSTAB VTAM-only keyword *
*
A31LG2C LINE MLTGPRI=60, *
            TGN=1 *
*
A31PG2C PU ADDR=04400000000431, *
           MAXDATA=5000 *

```

Figure 6-18 (Part 2 of 2). Example: Converting a Type 2 TIC to a Type 3 TIC (Before)

The following steps describe how to convert the type 2 TIC definition shown in Figure 6-18 on page 6-36 to a type 3 TIC definition.

- 1** Change the value of VERSION to V7R8F to include 3746 Model 900 support.
- 2** Code RETRIES on the SDLCST statement.
- 3** Change the value of ADAPTER from TIC2 to TIC3. (If you coded ADAPTER on the LINE definition statement, move it to the GROUP definition statement.)
- 4** Change the value of ADDRESS on the LINE definition statement to specify a 3746 Model 900 Token-Ring line number. Refer to *NCP, SSP, and EP Resource Definition Reference* for a list of 3746 Model 900 Token-Ring line numbers.
- 5** Delete the LU definition statement from the physical line definition.
- 6** Replace PHYPORT with PHYSRSC in each subarea logical line definition to associate each logical line with the physical connection to the Token Ring.

**Note:** The RCVBUFC keyword is ignored for 3746 Model 900 Token-Ring lines.

## Converting to 3746 Model 900 Token-Ring Resources

Figure 6-19 shows the sample generation definition after the conversion.

```

        BUILD VERSION=V7R8F,      NCP V7R8 with CSS support   1 *
        .
        .
        .
*
N31SEC  SDLCST RETRIES(4,2,1)   2
*
*****
*      3746 MODEL 900 PHYSICAL CONNECTIONS                    *
*****
*
A3137CS GROUP ADAPTER=TIC3,      3 *
              ANS=CONTINUE,      *
              ECLTYPE=(PHYSICAL,ANY), *
              ISTATUS=ACTIVE,     VTAM-only keyword *
              TRSPEED=16,        *
              USSTAB=AUSSTAB,    VTAM-only keyword *
              XID=NO
*
A31L2144 LINE ADDRESS=(2144,FULL), Line address in controller  4 *
          LOCADD=400000007041, This TIC's ring-station address *
          MAXTSL=3500, *
          PORTADD=10,      User-assigned ID number (0-99) *
          TRSPEED=16, *
          XMONLNK=YES
*
A31P2144 PU  PUTYPE=1          PUTYPE=1 added to GROUP by NDF
*
*****
*      3746 MODEL 900 PERIPHERAL LOGICAL LINES                *
*****
*
A31BNG2 GROUP ANS=CONTINUE, *
              AUTOGEN=3,      Adds 3 LINE and PU pairs *
              CALL=INOUT, *
              ECLTYPE=(LOGICAL,PER), *
              ISTATUS=ACTIVE, VTAM-only keyword *
              MODETAB=AMODETAB, VTAM-only keyword *
              PHYPORT=10      Associate logical with physical *
              RETRIES=(3,2,1), *
              USSTAB=AUSSTAB  VTAM-only keyword *
*

```

Figure 6-19 (Part 1 of 2). Example: Converting a Type 2 TIC to a Type 3 TIC (After)

```

*****
*      ALLOWS SUBAREA TRAFFIC BETWEEN THE 3746 MODEL 900      *
*      2144 LINE AND THE 1088 LINE OF A04 NCP                  *
*****
*
A31INNG3 GROUP ANS=CONTINUE,                                     *
                ECLTYPE=(LOGICAL,SUBAREA),                     *
                IPL=YES,                                        *
                ISTATUS=ACTIVE,      VTAM-only keyword         *
                MAXOUT=3,                                           *
                MODETAB=AMODETAB,   VTAM-only keyword         *
                MONLINK=YES,                                           *
                PHYRSC=A31P2144,   Associate logical with physical 6 *
                RETRIES=(3,2,1),                                       *
                SDLCST=(,N31SEC),   Name SDLCST definition statement *
                USSTAB=AUSSTAB     VTAM-only keyword           *
*
A31LG2C  LINE  MLTGPRI=60,                                       *
          TGN=1
*
A31PG2C  PU    ADDR=04400000000431,                               *
          MAXDATA=5000

```

Figure 6-19 (Part 2 of 2). Example: Converting a Type 2 TIC to a Type 3 TIC (After)

## Performance Characteristics

Several characteristics affect the performance of Token-Ring resources in the network. This section describes the Token-Ring data transfer and timing characteristics of Token-Ring resources. NCP buffer size and data transfer characteristics can also affect performance. See Chapter 24 for more information about NCP performance.

### Data Transfer

The three performance characteristics of data transfer are Token-Ring speed, frame size, and the number of frames that can be sent or received before being acknowledged (frame transmission window size).

#### Token-Ring Speed

Code the following definition statement and keyword to provide NCP with information about the Token-Ring speed for type 2 and type 3 TICs.

LINE	TRSPEED
------	---------

TRSPEED defines a Token-Ring speed of 4 Mbps or 16 Mbps. TRSPEED=16 is valid only for a type 2 or type 3 TIC. (Devices that operate at different speeds can be on different rings connected by a bridge.) If the TRSPEED value does not match the actual Token-Ring speed, physical line activation fails and the Token Ring appears to the adapter to be beaconing. If you do not code TRSPEED, NDF assumes 4 Mbps for a type 1 TIC and 16 Mbps for a type 2 or type 3 TIC.

When you code TRSPEED=16, the Token-Ring adapter uses early token release; otherwise, it uses normal token release. Early token release causes the adapter to

## Performance Characteristics

pass a token to another node immediately after a frame has been transmitted, instead of waiting until the adapter strips the transmitted frame from the ring.

### Frame Size

Resource allocation in the TIC and NCP requires a limit on the size of frames to be sent and received by NCP. Frame size is determined by a number of factors. When selecting a maximum frame size for a local Token-Ring station, consider the TIC type and the constraints of the workstation or adjacent NCP. When selecting a maximum frame size for a remote Token-Ring station, consider constraints imposed by the remote bridge or wide area link, the TIC type, and the workstation or adjacent NCP.

Code the following definition statements and keywords to provide NCP with information about the maximum frame sizes for transmitting and receiving data.

LINE	MAXTSL MAXFRAME RCVBUFC
PU	MAXDATA

## LINE

MAXTSL on the LINE definition statement determines the maximum amount of data, including the transmission header, the request header, and the response unit, that NCP can transmit. MAXTSL is valid only for Token-Ring physical lines. NCP uses the MAXTSL value to determine the maximum frame size for all SNA logical lines associated with a physical line.

When a frame-relay interface is defined on the Token-Ring, the larger value of MAXFRAME and MAXTSL determines the maximum amount of data, including the 802.2 LLC header and 2 byte DLCI data, that NCP can transmit over that frame relay interface. MAXFRAME limits the largest frame that can be transmitted for an associated NTRI frame handler logical line. MAXTSL limits the largest frame that can be transmitted over an SNA or IP interface.

The MAXTSL value should be greater than or equal to the MAXDATA value coded on the PU definition statement. If MAXTSL is less than MAXDATA, the maximum transmission size for that physical unit is reduced to the value of MAXTSL during logical connection activation. If transmission frames are larger than MAXTSL, they are segmented. If the Token-Ring station is in a multilink transmission group (MLTG) with other stations, the segment size can be reduced to the segment size of another station.

For NTRI subarea logical lines, the MAXTSL value can be reduced by a smaller RCVBUFC value specified in the other NCP and passed in an XID frame during logical connection activation. If this happens, frames larger than MAXTSL are segmented.

The type 1 TIC has only 2184 bytes of storage available for sending and receiving Token-Ring frames. Consider this when you select a value for MAXTSL because a large MAXTSL value causes frame transmission to use a large amount of the type 1 storage. If not enough storage is available to receive a frame, that frame is

not copied and must be resent by the other device. This condition is called TIC congestion and should be avoided if at all possible. The type 2 and type 3 TICs have 64KB of adapter storage, which is large enough that TIC congestion rarely occurs.

A less significant factor to consider in selecting a MAXTSL value is the number of frame retransmissions that could occur on that physical line due to frames lost because of line errors. A smaller frame size can reduce the number of frames lost. NCP uses the MAXTSL value to determine the maximum frame size for Token-Ring logical subarea connections. During the XID exchange for logical subarea connections, NCP determines the maximum frame size by selecting the smallest of the following values:

- Maximum transmission size of a physical line (MAXTSL)
- Largest frame size parameter of the bridge (this is generated by the bridge during route determination)
- Maximum PIU size supported by the other NCP.

When you define frame size for a NTRI connection, the MAXTSL value should be compatible with the RCVBUFC value.

For an MLTG, NCP determines the maximum frame size by selecting the smallest of the following values:

- Maximum transmission size specified for the group of links (MAXDATA)
- Maximum transmission size of a single link (MAXTSL)
- Largest frame size parameter of the bridge
- Maximum receive size of the link (RCVBUFC for NTRI connections).

For additional information about determining frame size, see *NCP and EP Reference*.

PIUs that are larger than the negotiated maximum segment size are split into smaller segments before transmission. When segments are received, they are reassembled before they are passed to their destination.

MAXFRAME defines the maximum frame relay frame size to be transmitted over a frame relay interface. The value you code should equal or exceed the maximum possible frame size. Specify the same value for MAXFRAME for all physical lines that support a PVC through any number of NCPs. See the DLCI information under "PU" page 16-32 for information about the relationship between MAXFRAME and DLCI on the PU definition statement.

RCVBUFC defines the NCP buffer capacity for receiving data from an IBM Token-Ring Network during one data transfer. The RCVBUFC value must be greater than or equal to the maximum number of bytes that will be received in one data transfer operation. Code RCVBUFC only for NTRI connections; RCVBUFC is ignored for 3746 Model 900 Token-Ring connections.

**Note:** If NTRI frame handler support is defined, MAXFRAME can be larger than RCVBUFC. This allows larger NTRI frame handler frames to be received.

For a physical line that supports peripheral connections, specify a RCVBUFC value that is greater than or equal to the largest frame that will ever be received. If a frame larger than that specified by RCVBUFC is received, the frame is ignored and an NMVT Alert is sent to the host. For subarea stations, RCVBUFC is passed to

## Performance Characteristics

the other subarea node during the XID2 exchange. This value influences the other subarea node's determination of its maximum frame size, so it is possible to select a value that is less than the maximum frame size and cause larger PIUs to be segmented.

### PU

MAXDATA on the PU definition statement specifies the maximum amount of data the device receives in one data transfer, that is, in one PIU or PIU segment (including the transmission header and request/response header). Refer to the documentation for a specific device to determine the amount of data it can receive. The maximum amount of user data NCP sends to the device is the value of MAXDATA minus 9 bytes. These 9 bytes represent the length of the transmission header (6 bytes) and the request/response header (3 bytes). Code MAXDATA on the PU definition statement on the VTAM switched major node definition for peripheral devices.

### Window Sizes for Sending and Receiving Frames

You can improve the performance of Token-Ring resources by adjusting the window sizes for sending and receiving information frames (I-frames) between NCP and an adjacent station. A window is the number of I-frames that can be sent or received between acknowledgments. By defining large windows, you can send and receive many I-frames between acknowledgments, which increases throughput. Of course, large windows can also increase the length of time NCP takes to detect congestion or frame loss.

**Note:** This section applies to SNA peripheral and subarea connections only.

Code the following definition statements and keywords to define window sizes for sending and receiving I-frames.

BUILD	T2TIMER
LINE	DYNWIND T2TIMER
PU	DYNWIND MAXOUT T2TIMER

### BUILD

T2TIMER defines the receive window size. NCP sends an acknowledgment to an adjacent station after the number of I-frames received from that station reaches the T2TIMER value. T2TIMER can be coded on the following definition statements:

- T2TIMER on the BUILD defines the receive window size for all Token-Ring logical lines in the network
- T2TIMER on the logical subarea LINE defines the receive window size for a specific subarea link
- T2TIMER on the logical subarea PU defines the receive window size for a specific physical unit.

T2TIMER defined on the PU or LINE definition statement overrides the value specified on the BUILD.

**Note:** T2TIMER must be coded on the PU definition statement for dynamic reconfiguration and switched PU support via VTAM.

## LINE

DYNWIND can be coded on the GROUP, LINE, or PU statement for a physical line or a subarea logical line. DYNWIND specifies the values to be used by NCP to modify the IEEE 802.2 LLC working window parameter. The values specified increment the size of the working window or control how quickly the working window should be closed or dropped when frame loss or congestion occurs. When you code DYNWIND on a physical line definition, the values specified apply to all non-leased logical lines associated with that physical line, unless the values are coded in the VTAM switched major node.

DYNWIND defines the following values:

*nw*

The IEEE 802.2 LLC *Nw* parameter. When NCP detects frame loss or congestion, NCP reduces the transmission window size by the amount specified by the *dw* or *dwc* parameter. After this happens, NCP increases the window size after *Nw* frames transmitted by NCP are received and acknowledged by the adjacent station. This process continues until the window size reaches the maximum (MAXOUT on the PU definition statement).

**NTRI:** *dw* and *dwc*

The rates at which the window size decreases when frame loss or congestion occurs. The default for the *dw* value causes NCP to decrease the window size to 1 immediately upon recognizing a lost frame. This conforms to the IEEE 802.2 logical link control (LLC) protocol. The default for *dwc* results in no change to the window when NCP assumes congestion (RNR frame received). You can increase the transmission rate by coding values that cause the window size to decrease more slowly. See the description of the DYNWIND keyword on the PU statement in *NCP, SSP, and EP Resource Definition Reference* for a list of valid *dw* and *dwc* values and their effects on the working window.

## PU

MAXOUT on the PU definition statement defines the transmission window size. This is the maximum number of I-frames NCP is to send to the adjacent station without receiving an acknowledgment from the station.

For a peripheral physical unit, code MAXOUT on the PU definition statement in the VTAM switched major node definition. See *VTAM Resource Definition Reference* for the range of values for MAXOUT. For a subarea physical unit, code MAXOUT on the PU definition statement in the NCP generation definition.

NCP sends frames until the number of frames reaches MAXOUT. If NCP has not received a response by this time, NCP stops sending and waits for a link-level acknowledgment. If NCP receives a link-level acknowledgment before reaching MAXOUT, it resets the frame count to 0 and starts counting frames after the last frame acknowledged. All frames sent are kept in NCP storage until the acknowledgment is received.

Using a higher value of MAXOUT results in high utilization of the Token-Ring connection to the device. In a remote LAN environment, where the connection is across a wide area network, consider the following issues:

## Performance Characteristics

- The MAXOUT value needs to be large enough for NCP to transmit frames steadily to the wide area network without introducing needless waiting for frequent acknowledgments.
- If the MAXOUT value is too high, the remote bridge will suffer congestion from a single NCP monopolizing its transmission resources.

### Sample Definition for Token-Ring Performance

Figure 6-20 shows how MAXTSL, RCVBUFC, and T2TIMER can be used to improve Token-Ring performance. The largest frame to be sent over the Token-Ring connection is 4060 bytes. Therefore, the transmit frame size and the receive buffer capacity (MAXTSL and RCVBUFC) are set to 4060 bytes to enable the maximum amount of data to be transmitted in each frame. You can reduce Token-Ring traffic if you code T2TIMER, which causes NCP to receive two data frames before sending an acknowledgment. (For peripheral connections, NCP always uses a value of 2 for the third parameter of T2TIMER.)

Code MAXDATA=4060 and MAXOUT=3 on the VTAM switched major node definition for each of the physical units on the Token Ring. This causes NCP to wait for an acknowledgment whenever the number of unacknowledged transmission frames reaches 3 before transmitting any more frames to the Token-Ring device.

The default Token-Ring speed for TIC2 adapters (TRSPEED=16) is used by all nodes on the Token Ring.

TRNCP	BUILD	T2TIMER=(.5,1.5,2)	
TRAGRP	GROUP	ADAPTER=TIC2, ECLTYPE=(PHYSICAL,PERIPHERAL)	
TRALN1	LINE	ADDRESS=(1088,FULL), DYNWIND=8, LOCADD=400037450101, MAXTSL=4060, RCVBUFC=4060, PORTADD=1	Line addr in controller chassis Slower send window recovery This TIC's ring-station address Size of frames transmitted Size of receive buffer User-assigned ID number (0-99)
TRAPU1	PU		
*			
LTRAGR1	GROUP	ECLTYPE=(LOGICAL,PERIPHERAL), PHYSRSC=TRAPU1, CALL=INOUT, AUTOGEN=40	Associate logical resource with PU NCP or devices can initiate Adds 40 LINE and PU pairs

Figure 6-20. Example: Defining Token-Ring Performance

## Timers for Logical Connections

NCP uses three types of timers for Token-Ring logical connections: the reply timer (T1), the acknowledgment timer (T2), and the inactivity timer (TI). This section describes the functions of these timers and how to define values for them.

### Reply Timer

NCP uses the reply timer (T1) to detect a failure to receive a required acknowledgment from a link station on a local or remote ring in the IBM Token-Ring Network. If NCP does not receive an acknowledgment from a link station within the specified time interval following the establishment of a logical connection with that link station, NCP solicits an acknowledgment.



Code the following definition statement and keywords to provide NCP with performance information about the reply timers.

```
BUILD          LOCALTO
                REMOTTO
                T1TIMER1
```

<sup>1</sup> Supported starting with NCP V7R3.

T1TIMER on the BUILD definition statement specifies the timer interval values for acknowledgments from a local and remote ring in the IBM Token-Ring Network. The *localt1* value is used for all locally attached connections. The *remott1* value is used for all remotely attached connections. Unique values for logical subarea lines can be specified using T1TIMER on the GROUP, LINE, or PU definition statement.

Before T1TIMER was introduced in NCP V7R3, you needed to specify reply timer values for local and remote connections separately using the LOCALTO and REMOTTO keywords. LOCALTO specifies the value for locally attached connections and REMOTTO for remotely attached connections.

Values used for the reply timer by NCP and the adjacent link station should be similar. Using values that differ by a factor of 5 or more can result in performance problems and unnecessary station INOP requests.

### Acknowledgment Timer

NCP provides an acknowledgment timer (T2) that causes NCP to delay sending acknowledgments of I-frames received over a Token-Ring logical connection. You can use the acknowledgment timer in conjunction with the acknowledgment window size to improve performance by delaying the acknowledgment of received I-frames.

If the acknowledgment timer is not already running, NCP starts it when NCP receives an I-frame. NCP receives subsequent I-frames without sending an acknowledgment until the acknowledgment timer expires, or the number of I-frames received reaches the value specified for the window size. NCP sends an acknowledgment in either case. If you do not use the acknowledgment timer, NCP sends an acknowledgment for each received I-frame. You can specify a separate acknowledgment delay for local and remote Token Rings. Specify a delay of 0 for either of these Token-Ring types to disable the acknowledgment timer for that type and acknowledge every I-frame received.

Code the following definition statement and keyword to define an acknowledgment timer.

```
BUILD          T2TIMER
LINE           T2TIMER
```

**T2TIMER** on the BUILD definition statement defines the acknowledgment timer value for all Token-Ring logical lines in the network. T2TIMER on the LINE definition statement for the logical subarea line defines the acknowledgment timer value for a specific logical subarea line, overriding the value specified on the BUILD

## Performance Characteristics

definition statement. The T2TIMER keyword has separate suboperands for timer values for local and remote connections.

The local or remote acknowledgment timer value should be approximately one-tenth the value specified for the reply timer for the adjacent station. This ensures that the adjacent station receives the acknowledgment before its reply timer expires. If there are peripheral stations that use a MAXOUT of 1, specify acknowledgment timer values no longer than 0.2 seconds to avoid degrading link throughput. If there are many peripheral stations that use a MAXOUT of 1, you should consider not using the acknowledgment timer.

The acknowledgment window size for local and remote Token Rings is equal to the number of I-frames to be received before NCP must acknowledge transmission. When the number of frames received equals the defined window size, NCP sends an acknowledgment, even if the acknowledgment timer has not expired. If the acknowledgment timer is used for peripheral connections, NCP uses a value of 2 for window size. The acknowledgment window size should be less than the value of MAXOUT specified by the other NCP or other device.

### Inactivity Timer

NCP provides an IEEE 802.2 LLC inactivity timer (TI) for each logical connection. The inactivity timer determines how long NCP will wait without receiving a frame from the adjacent station. If NCP has not received a frame from the adjacent station by the time the inactivity timer expires, NCP polls the station to determine whether it is still active. NCP starts the inactivity timer when the link to the station is activated, and resets the timer whenever a frame is received from the station.

Code the following definition statement and keyword to define the inactivity timer value.

LINE	TITIMER
------	---------

**TITIMER** on the LINE definition statement for the *physical* line defines the inactivity timer value. (TITIMER is coded for the physical line because the factors that determine the optimum value are related to the topology of the network.) The default value of 60 seconds is suitable for most applications. Larger values can cause a delay in detecting inactive stations, and smaller values can cause excessive polling.

### Sample Coding for Logical Connection Timers

Figure 6-21 on page 6-47 shows how to code values for NCP timers for a specific logical line. You can also code timer values on the BUILD and PU definition statements.

In the following example, NCP waits 2.5 seconds for replies from nodes on both local and remote Token Rings, after which it sends a specific request for acknowledgment. NCP sends an acknowledgment within the next 0.3 seconds following the reception of an I-frame, regardless of whether the sending node is on a local or remote Token Ring. NCP also sends an acknowledgment when 3 I-frames are received since the last acknowledgment.

```
LSUBLNA LINE T1TIMER=(2.5,2.5)
          T2TIMER=(0.3,0.3,3)
```

Figure 6-21. Example: Defining Timers for Logical Connections

## Logical Line Error Recovery and Retries

Logical connection error recovery is controlled by reply and inactivity timer values and error recovery retry sequence values. If a reply is not received before the reply timer expires, the number and frequency of attempts to retransmit the data is determined by the value coded on the RETRIES keyword on the LINE definition statement. See “Reply Timer” on page 6-44 for complete information about reply timers.

## Logical Line Retries

Logical connections can fail during data transmission from one resource to another over a logical line. Code the following definition statement and keyword to provide NCP with information about how to retransmit data.

```
LINE          RETRIES
```

**RETRIES** on the LINE definition statement specifies the following:

- The number of retry sequences
- The number of retransmissions within each retry sequence
- The pause time in seconds between retry sequences
- The number of retransmissions (there is no pause followed by additional retries for local connections).

You can define RETRIES values for each Token-Ring logical line. For local logical lines, specify only the number of retransmissions. For remote logical lines, specify only the number of retry sequences, the number of retransmissions within each retry sequence, or the pause time before each retry sequence.

NCP cannot detect when a remote Token Ring connected by a bridge is in automatic error recovery, so the retry time for remote Token Rings should be long enough to permit the Token Ring to recover.

### Sample Definition for Error Recovery and Retries

Figure 6-22 shows how to code retry values to define the number of retransmissions to be attempted during error recovery. NCP is to retry the transmission 6 times when the error is for a node on a local Token Ring. NCP is to perform 10 retry sequences of 10 retries with a 4-second wait between retry sequences when the error is for a node on a remote Token Ring.

```
LSUBLNA LINE RETRIES=(10,4,10,6)
```

Figure 6-22. Example: Defining Logical Connection Error Recovery and Retries

### Remote Loading and Activation over a Token-Ring Line

You can use a Token-Ring subarea link to load an NCP load module into a remote communication controller containing an active NCP, and then activate the new NCP through SMMF. To do this, the active NCP in the remote controller must include a Token-Ring subarea link defined with:

- XMONLNK=YES on the PU definition statement for the physical line
- IPL=YES and MONLINK=YES on the LINE definition statement for the logical subarea line.

For a complete description of the process for remote loading and activation, refer to *NCP, SSP, and EP Generation and Loading Guide*.

### Sample Token-Ring Resource Definitions

The following sample generation definition shows how to define Token-Ring subarea and peripheral resources. (See “Defining NTRI Attachments for a Frame-Relay Network” on page 16-63 for a sample generation definition of how to define frame-relay stations on Token-Ring.

NDF adds some of these definition statements and keywords automatically. For more information on NDF-generated keywords, see “NDF-Generated Additions for Token-Ring Resources” on page 6-4.

Figure 6-23 shows an NCP (NCP1) with a NTRI and a 3746 Model 900 physical connection to two separate Token Rings and three logical lines. Two logical lines support connections to peripheral Token-Ring nodes and one logical line supports a subarea connection to another NCP (NCP2).

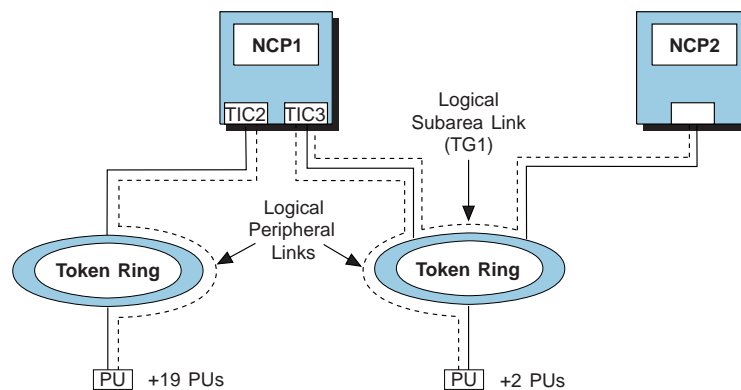

Figure 6-23. Token-Ring Physical and Logical Lines

Figure 6-24 on page 6-49 shows a sample generation definition for NCP1 with the Token-Ring resources shown in Figure 6-23.

## Sample Token-Ring Resource Definitions

```

*****
* NCP/TOKEN RING INTERCONNECT - PHYSICAL CONNECTIONS *
*****
*
A31NTR1 GROUP ADAPTER=TIC2, *
              ANS=CONTINUE, *
              ECLTYPE=(PHYSICAL,ANY), *
              NPACOLL=(YES,EXTENDED), *
              TRSPEED=4, *
              USSTAB=AUSSTAB, VTAM-only keyword *
              XID=NO
*
*****
* NTRI SUBAREA AND PERIPHERAL MIXED PHYSICAL CONNECTION *
*****
*
A31TR88 LINE ADDRESS=(1088,FULL), Line address in controller chassis *
          LOCADD=400000003131, This TIC's ring-station address *
          MAXTSL=4060, *
          PORTADD=1, User-assigned ID number (0-99) *
          RCVBUFC=32000
*
A31PU88 PU
          .
          .
          .
A31PGRP2 GROUP ADAPTER=TIC2, *
              ANS=STOP, *
              ECLTYPE=(PHYSICAL,PER), *
              NPACOLL=(YES,EXTENDED), *
              TRSPEED=16, *
              USSTAB=AUSSTAB, VTAM-only keyword *
              XID=NO
*
*****
* NTRI PERIPHERAL PHYSICAL CONNECTION -- SAME LOCADD AS IN A04REGC *
*****
*
A31TR89 LINE ADDRESS=(1089,FULL), Line address in controller chassis *
          LOCADD=400000000032, This TIC's ring-station address *
          MAXTSL=16384, *
          PORTADD=2, User-assigned ID number (0-99) *
          RCVBUFC=32000
*
A31PU89 PU
*

```

Figure 6-24 (Part 1 of 3). Example: Defining Token-Ring Physical and Logical Lines

## Sample Token-Ring Resource Definitions

```

*****
* NTRI PERIPHERAL LOGICAL LINES - GENERATED IN NEWDEFN          *
*                               USED WITH A31TR88 AND/OR A31TR89  *
*****
*
A31BNG1 GROUP ANS=CONTINUE,                                     *
              AUTOGEN=20,           Adds 20 LINE and PU pairs    *
              CALL=INOUT,          *
              ECLTYPE=LOGICAL,      *
              ISTATUS=ACTIVE,       VTAM-only keyword            *
              MODETAB=AMODETAB,     VTAM-only keyword            *
              NPACOLL=(YES,EXTENDED), *
              PHYPORT=NONE,         Not associated with physical line *
              RETRIES=(10,10,10,10), *
              USSTAB=AUSSTAB,       VTAM-only keyword            *
              XMITDLY=NONE
*
.
.
.
*****
*           3746 MODEL 900 PHYSICAL CONNECTIONS                   *
*****
*
A3137CS GROUP ADAPTER=TIC3,                                     *
              ANS=CONTINUE,                                     *
              ECLTYPE=(PHYSICAL,ANY),                          *
              ISTATUS=ACTIVE,       VTAM-only keyword            *
              TRSPEED=16,           *
              USSTAB=AUSSTAB,       VTAM-only keyword            *
              XID=NO
*
A31L2144 LINE ADDRESS=(2144,FULL), Line address in 3746 Model 900 *
              LOCADD=400000007041, This TIC's ring-station address *
              MAXTSL=3500,          *
              PORTADD=10,           User-assigned ID number (0-99) *
              TRSPEED=16,          *
              XMONLNK=YES
*
A31P2144 PU   PUTYPE=1           PUTYPE=1 added to GROUP by NDF
*
*****
*           3746 MODEL 900 PERIPHERAL LOGICAL LINES               *
*****
*
A31BNG2 GROUP ANS=CONTINUE,                                     *
              AUTOGEN=3,           Adds 3 LINE and PU pairs    *
              CALL=INOUT,          *
              ECLTYPE=(LOGICAL,PER), *
              ISTATUS=ACTIVE,       VTAM-only keyword            *
              MODETAB=AMODETAB,     VTAM-only keyword            *
              PHYRSC=A31P2144,     Associate logical with physical *
              RETRIES=(3,2,1),     *
              USSTAB=AUSSTAB       VTAM-only keyword            *
*

```

Figure 6-24 (Part 2 of 3). Example: Defining Token-Ring Physical and Logical Lines

## Sample Token-Ring Resource Definitions

```
*****
*           ALLOWS SUBAREA TRAFFIC BETWEEN THE 3746 MODEL 900           *
*           2208 LINE AND THE 1088 LINE OF A04 NCP.                       *
*****
*
A31INNG3 GROUP ANS=CONTINUE,                                             *
                ECLTYPE=(LOGICAL,SUBAREA),                               *
                IPL=YES,                                                 *
                ISTATUS=ACTIVE,      VTAM-only keyword                  *
                MAXOUT=3,                                                 *
                MODETAB=AMODETAB,    VTAM-only keyword                  *
                MONLINK=YES,                                               *
                PHYSRSC=A31P2144,    Associate logical with physical    *
                RETRIES=(3,2,1),                                           *
                SDLCST=(,N31SEC),                                          *
                TGCONF=MULTI,                                              *
                USSTAB=AUSSTAB      VTAM-only keyword                    *
*
A31LG2C  LINE  MLTGPRI=60,                                             *
          TGN=1
*
A31PG2C  PU    ADDR=04400000000431,                                     *
          MAXDATA=5000
```

Figure 6-24 (Part 3 of 3). Example: Defining Token-Ring Physical and Logical Lines





---

## Chapter 7. Integrated Services Digital Network (ISDN) Resources

This chapter describes NCP support for the integrated services digital network (ISDN) protocol. It covers the following subjects:

- Introduction to 3746 Model 900 ISDN
- Defining ISDN physical lines
- Defining ISDN logical lines
- Remote loading and activation over an ISDN line
- Coding ISDN definitions for best performance
- ISDN accounting
- Sample ISDN configurations and definitions.

---

### Introduction to 3746 Model 900 ISDN

This section introduces the integrated services digital network (ISDN) protocol and the 3746 Model 900 ISDN functions, defines some important terms used in this chapter, and summarizes the general approach for defining 3746 Model 900 ISDN connections.

### What Is ISDN?

Integrated services digital network (ISDN) is an Open Systems Interconnection (OSI) protocol for a public or private end-to-end digital telecommunications network. ISDN supports multiple services including voice and data transmission. Some examples of devices that might have an ISDN interface are a digital telephone, an integrated digital voice or data terminal, and digital facsimile equipment. An ISDN network is composed of full-duplex digital channels that carry signaling information (on ISDN D-channels<sup>1</sup>) or user data (on ISDN B-channels) between these devices through a 3746 Model 900 connectivity subsystem.

Starting with NCP V7R5, the 3746 Model 900 connectivity subsystem (CSS) supports an interface into existing ISDN environments for SNA sessions routed through the CSS. NCP ISDN resources provide WAN connections to other routers, such as the 2210, or end systems to provide SNA connectivity. Figure 7-1 on page 7-2 shows two 3746 Model 900s functioning in a sample ISDN network.

---

<sup>1</sup> Some devices use the ISDN D-channel to carry X.25 data as well as signaling information. However, with the 3746 Model 900 connectivity subsystem, D-channels are used exclusively for signaling information.

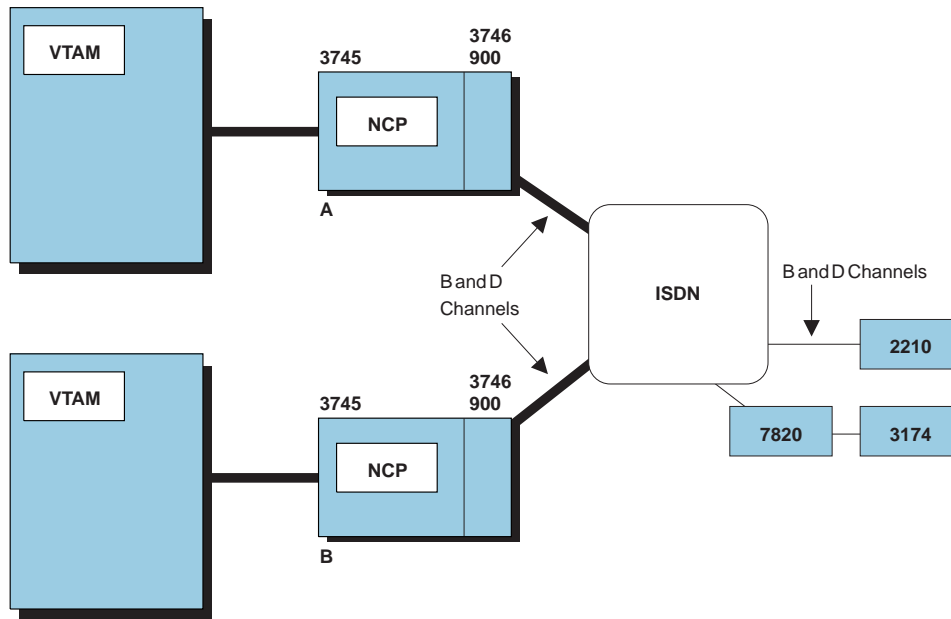

Figure 7-1. ISDN Connections

**NCP ISDN Connections:** The NCP ISDN function supports the Euro-ISDN standard. NCP 3746 Model 900 CSS provides a native primary rate interface, with a combination of 30 ISDN B-channels for user data and one ISDN D-channel for signaling information.

Switched logical lines represent connections over the B-channels. NCP communicates using frame-relay protocols for these logical resources. This support enables multiplexing over the same interface and other functions, such as frame sequencing, error recovery, and congestion recovery. Figure 7-1 illustrates these NCP frame-relay connections. The following list describes some of the connections shown in the figure.

### ISDN subarea links

For A, the terminating equipment function exchanges frames with B over frame-relay subarea links. The subarea link between A and B passes through the ISDN network. An ISDN subarea link can be part of a multilink transmission group (MLTG), along with SDLC and Token-Ring subarea links. MLTG capability enables you to increase bandwidth by aggregating multiple B-channels.

For more information, see “Defining ISDN Logical Subarea Lines” on page 7-13.

### ISDN peripheral links

For B, the terminating equipment function exchanges frames with peripheral devices over frame-relay peripheral links. B can also communicate with A over an APPN peripheral link when each belongs to a composite network node.

For more information, see “Defining ISDN Logical Peripheral Lines” on page 7-18.

**Advantages of ISDN:** ISDN networks are based on 64-Kbps switching technology and are intended to supply current voice facilities, existing data services, and many new and extended services. ISDN is advantageous when you do not need a constant, dedicated connection because you pay only for the duration of a call.

ISDN is a layered protocol that follows the general guidelines set forth in the Open Systems Interconnection (OSI) seven-layer model. ISDN defines a full network architecture. This architecture separates access functions (how to get into the network) from actual network functions (those internal to the network). Of key importance to ISDN is how access nodes interact with the user rather than how elements within the network interact with each other.

**Call-on-Demand:** NCP with the 3746 Model 900 can initiate a call to remote data terminating equipment (DTE) or receive a call from remote DTE. This connection can be set up using the following methods:

- An application request for a temporary connection
- A command list (C-list), for example, one that is used for scheduled data transfer during peak periods.

When you code your generation definition, you need to decide if you will establish and check ISDN connections using the party number or the party subaddress.

**Frame-Relay Backup:** 3746 Model 900 nonswitched frame-relay links can be backed up over an ISDN line attached to the same 3746 Model 900. You must define the 3746 Model 900 nonswitched frame-relay physical line as eligible for ISDN backup. If the frame-relay line fails, the CSS automatically reroutes the traffic to the specified ISDN line. See “Defining Automatic Frame-Relay Backup over an ISDN” on page 16-22 for more information.

## NCP ISDN Terms

It will help you to know the following terms as you read about how to define NCP ISDN resources:

### *ISDN D-Channel*

A full-duplex digital channel that carries signaling information to the ISDN network. An NCP D-channel definition represents the physical line.

### *ISDN B-Channel*

A full-duplex digital channel that carries user data through the ISDN network. An NCP B-channel definition represents a time slot on a D-channel.

### *Primary Rate Interface (PRI)*

A combination of 23 or 30 ISDN B-channels for user data and one ISDN D-channel for signaling information. NCP supports the Euro-ISDN PRI which has an access rate of 2.048 Mbps and uses 30 ISDN B-channels.

### *Terminal Adapter (TA)*

An adapter that enables data terminating equipment (DTE) that does not have a native ISDN interface to connect to the ISDN environment.

### Definition Statements for Defining ISDN Resources

The actual hardware interface to ISDN is represented by the physical line (ISDN D-channel) definitions. The bandwidth of the channel is divided into time slots. An ISDN B-channel definition represents a time slot. Although an ISDN B-channel is a logical entity, it acts similarly to a frame-relay physical line with ISDN resources multiplexed over it. An ISDN B-channel is defined to NCP in a similar way as a physical line.

NCP applies a frame-relay protocol for sending data across logical lines associated with an ISDN B-channel. Data link connection identifiers (DLCIs) identify logical connections. Supports exchange DLCI status information with adjacent nodes on DLCI 0 using the frame-relay local management interface (LMI) protocol over the ISDN-B channels. See Chapter 16, "Frame-Relay Resources" on page 16-1 for information about NCP frame-relay support and definitions. Frame handler subports are not supported with ISDN connections.

The characteristics of the ISDN B-channel and logical station are specified on the DLCADDR keyword on the VTAM PATH definition statement and on the ISDN physical resource definition statements. ISDN physical and logical lines are defined using GROUP, LINE, and PU definition statements. You can define up to 33 physical lines, depending on the controller model. Define at least one and up to 30 ISDN B lines per physical line. The physical line definition statements must appear in the system generation definition before the ISDN logical line definitions.

Use the following general approach to define NCP ISDN connections.

1. Code a GROUP definition statement to define the physical line (D-channel) to represent the actual hardware interface to ISDN.
  - Under the GROUP definition statement, code one or more LINE definition statements to define the physical lines.
  - Under each LINE definition statement, code a PU definition statement to define the link-station subport.
2. Code a GROUP definition statement to define the B-channels as switched resources.
  - Under the GROUP definition statement, code one or more LINE definition statements to define the single-point switched lines.
  - Under each LINE definition statement, code a PU definition statement to define the LMI subport.
3. Code a GROUP definition statement to define a group of switched logical lines. You can define groups of logical lines to support subarea links and peripheral links. A single group can define subarea lines or peripheral lines, but not both. Under the GROUP definition statement, code one or more of the following pairs:
  - A LINE definition statement to define a logical subarea or peripheral line
  - A PU definition statement to define the TESP for the logical line.

Sample definitions of individual NCP ISDN resources appear at the end of each section in this chapter. A definition of a sample NCP ISDN network appears at the end of the chapter.

When defining ISDN resources, code NEWDEFN=(YES,...) to cause NDF to create a new generation definition (*NEWDEFN file*), which must be used to define the NCP major node in the VTAM system definition. For more information on NEWDEFN files, see “NDF-Generated Definition File” on page 2-1.

---

### Defining ISDN Physical Lines (D-Channels)

An ISDN physical line is a single-point leased line providing a connection between the 3746 Model 900 and the ISDN. When you define the ISDN physical line, you are defining the ISDN D-channel that carries signaling information for the ISDN logical connections. Define an ISDN interface as a leased line with a single PU definition statement, which represents the ISDN D-channel and defines the link station subport.

Code the following definition statements and keywords to define an ISDN physical line (ISDN D-channel).

GROUP	DIAL ISDN
LINE	ADDRESS CIR <sup>2</sup> DATBLK ISDNLPN ISDNLSA LOCADD LSPRI MAXDLCI <sup>1</sup> MAXFRAME PORTADD SPEED TITIMER
PU	ANS DYNWIND ERRORT INNPORT ISDNCFG ISDNDSCT LLERP LMI MAXDLCI <sup>1</sup> PUTYPE SPOLL TIMERS XMONLNK
<sup>1</sup> Supported starting with NCP V7R6. <sup>1</sup> Supported starting with NCP V7R7.	

Some of the LINE definition statement keywords, such as DYNWIND, can also be coded at the logical line level. If the characteristic applies to any logical line associ-

## Defining ISDN Physical Lines

ated with the physical line, it is more convenient to define it at this level. The ISDNLPN, ISDNLSA, and LMI keywords can be overridden in the VTAM DLCADDR keyword elements in the switched major node for a specific dial-out connection to a logical line. See “Defining Device Addresses to VTAM” on page 7-22 for more information.

### GROUP

DIAL on the GROUP definition statement specifies whether the lines in the group require switched line control procedures. Code DIAL=NO when you define ISDN physical lines.

ISDN on the GROUP definition statement specifies the type of ISDN line. Code ISDN=PHYSICAL when you define ISDN physical lines.

### LINE

ADDRESS on the LINE definition statement specifies the relative line number of the physical line. Code an address in the range for a 3746 Model 900 CLP port. The address must be the first address of port 0 or 1 for 3746 Model 900 CLP positions.

CIR on the LINE definition statement specifies whether the committed information rate algorithms should be used for bandwidth management. See the *3745 Communication Controller Models A, 3746 Expansion Unit Model 900: Migration and Planning Guide*, GA33-0183, for more information about the Model 900 CIR processing.

DATABLK on the LINE definition statement specifies the minimum transmission bandwidth in bytes that can be allocated to a resource. DATABLK is used with the *priority* suboperand of the COMRATE keyword to determine a relative priority among resources. The value of the *priority* suboperand of COMRATE is multiplied by the value of DATABLK to determine the maximum number of bytes that a resource can transmit before a different resource must be given a transmit opportunity.

ISDNLPN on the LINE definition statement specifies the local party number. The value you specify is the ISDN address for the physical interface. It will be the called number when receiving calls and the calling number when making calls. The local (calling) party number must be defined according to the ITU-T Q.931 recommendation. See *NCP, SSP, and EP Resource Definition Reference* for information about the format.

ISDNLSA on the LINE definition statement specifies the ISDN subaddress for the physical interface. The local (calling) party subaddress must be defined according to the ITU-T Q.931 recommendation. See *NCP, SSP, and EP Resource Definition Reference* for information about the format.

LOCADD on the LINE definition statement specifies the NCP virtual MAC address used by remote BAN routers for ISDN connections. This MAC address is sometimes referred to as the BAN identifier in the BAN router. The value specified for LOCADD must be the same in all routers that will have BAN connections to NCP for all DLCIs over this physical line. The value used for the NCP virtual MAC address should not match the MAC address of a LAN-attached station within your network. The MAC address does not have to be unique across your ISDN or frame-relay interfaces.

LSPRI on the LINE definition statement specifies whether NCP is to use transmission priority to determine the order in which PIUs are sent to the physical unit

over a logical peripheral line. For ISDN physical lines that support logical peripheral lines, you can specify either LSPRI=NO (the default) or LSPRI=PU.

MAXDLCI on the LINE or PU definition statement specifies the maximum number of DLCIs for the associated B-channels, because the value is applied to all of the associated B-channel resources. The value you code should equal or exceed the expected number of DLCIs for any given B-channel. If no LMI support is defined on the physical link-station support, the maximum value for MAXDLCI is 991. If LMI support is defined, the maximum value is determined by the following expression (converted to hexadecimal):

$$((maxframe - fixed) \div 5) + 15$$

where:

*maxframe* is the value of MAXFRAME for this line.

*fixed* is 17 when LMI=CCITT or LMI=CCITT-NUI.

*fixed* is 18 when LMI=ANSI or LMI=ANSI-NUI.

MAXFRAME on the LINE definition statement defines the maximum size frame to be transmitted through the ISDN. The value you code should equal or exceed the maximum possible frame size.

PORTADD on the LINE definition statement identifies to VTAM the port numbers of the ISDN physical lines. PORTADD values of 0–254 are supported for ISDN lines. PORTADD is required. The PORTADD values must be unique for each 3746 Model 900 ISDN adapter, but they can be the same as values coded for 3746 Model 900 Token-Ring or frame-relay physical lines.

See “Defining Device Addresses to VTAM” on page 7-22 for more information about correlating VTAM switched major node addressing information with NCP resources.

SPEED on the LINE definition statement sets the data rate for a line. Code SPEED=2048000. If SPEED=2048000 is not coded, NDF adds it.

TITIMER on the LINE definition statement defines the IEEE 802.2 LLC inactivity timer (TI) value for all SNA logical subarea and peripheral connections (*not* frame-relay PVCs) on the physical line. The inactivity timer determines how long NCP will wait without receiving a frame from the adjacent device. If NCP has not received a frame from the adjacent device by the time the inactivity timer expires, NCP polls the device to determine whether it is still active. NCP starts the inactivity timer when the link to the device is activated, and resets the timer whenever a frame is received from the device. The default value of 60 seconds is suitable for most applications. Larger values can cause a delay in detecting inactive devices, and smaller values can cause excessive polling.

## PU

ANS on the PU definition statement specifies whether the ISDN physical line is to stop or continue to operate when NCP enters automatic network shutdown (ANS). Code ANS=CONTINUE.

DYNWIND on the PU definition statement defines the dynamic characteristics of the frame transmission window for the logical subarea or peripheral physical unit associated with this physical line. This window is the number of frames NCP can send

## Defining ISDN Physical Lines

before waiting for an acknowledgment. The maximum window size for each logical connection is defined by MAXOUT on the PU definition statement.

DYNWIND defines the following values for ISDN physical lines:

*dw* and *dwc*

The rates at which the window size decreases when frame loss or congestion occurs. The default values for these rates cause NCP to decrease the window size to 1 immediately, in conformance with the IEEE 802.2 logical link control (LLC) protocol. You can increase the transmission rate by coding values that cause the window size to decrease more slowly. See the description of the DYNWIND keyword on the PU statement in *NCP, SSP, and EP Resource Definition Reference* for a list of valid *dw* and *dwc* values and their effects on the working window.

*nw*

The rate at which the window size increases after it has been decreased by frame loss or congestion. This is the IEEE 802.2 LLC *Nw* parameter. After NCP has decreased the transmission window size, NCP increases the window size after *Nw* frames transmitted by NCP are received and acknowledged by the adjacent device. This process continues until the window size reaches its maximum.

ERRORT on the PU definition statement defines the error threshold at which NCP terminates communication with an adjacent ISDN node. The threshold is the number of errors out of a number of consecutive events. Code ERRORT and TIMERS on the PU definition statement for the link-station support to monitor the integrity of the ISDN B-channels associated with the physical line. ERRORT is not valid if you specify LMI=NO for the link-station support.

INNPORT on the PU definition statement specifies whether a physical unit will remain active when CDLINK=ACT is specified on either the HALT or VARY INACT commands. Code INNPORT=YES. If INNPORT=YES is not coded, NDF adds it.

ISDNCFG on the PU definition statement specifies the ISDN channel configuration, specifically whether cyclic redundancy check (CRC) is included in frames to detect frame loss. Code ISDNCFG=CRC if the ISDN that you are attaching to requires it.

ISDNDSCT on the PU definition statement specifies the delayed disconnect time, which is the number of seconds that the 3746 Model 900 should wait before bringing down the associated ISDN B-channel after the last logical station disconnects. Coding ISDNDSCT=NO causes an ISDN B-channel to remain active even when the B-channel does not have any associated logical stations. Because ISDN charges are time-related, coding ISDNDSCT=NO is not recommended.

For information about controlling when a logical subarea station disconnects, see the NCP BRKCON keyword description on 7-16. For information about controlling when a logical peripheral station disconnects, see the VTAM DISCNT keyword description in *VTAM Resource Definition Reference*.

LMI specifies whether the link-station support is to support the LMI protocol, and if so, the LMI protocol standard that NCP is to use. If you code LMI=ANSI or LMI=CCITT, NCP determines the level of LMI support required to communicate with the adjacent ISDN node during activation of the LMI support. The level of support used by NCP can be one of the following:



- No LMI support
- Request LMI status only
- Respond to LMI status requests only
- Bidirectional support to request LMI status and respond to LMI status requests.

The LMI standard used by the ISDN node at each end of an ISDN B-channel connection associated with the physical line can be ANSI, the United States standard, or CCITT, the international standard. Code the first suboperand to indicate which standard is to be used by your NCP. Use the same LMI standard at both ends of a connection; mismatched LMI standards can cause an interruption in LMI processing and can prevent activation of a physical link. The connection does not have an intervening network.

When -NUI (CCITT-NUI or ANSI-NUI) is specified, no discovery of the LMI protocol will be done. NUI (Network-to-User Interface) indicates that NCP will respond to LMI status requests but NCP will not request LMI status. The -NUI option can be used when the adjacent node only requests LMI status in order to speed activation of the interface.

For ISDN, you do not need to code the last LMI suboperand because that suboperand is used only to indicate echo detection, which is not required for ISDN.

LLERP on the PU definition statement specifies whether the link station will perform link-level error recovery procedures (ERPs) when sending HPR data on this link station. Specify LLERP=NOTPREF if you want NCP to bypass the error recovery procedures; it is best to bypass link-level ERP when transmitting HPR data over highly reliable lines. Specify LLERP=REQUIRED only if the line quality is poor and the adjacent node supports the use of link-level ERP for HPR data.

PUTYPE specifies the type of physical unit being defined. Code PUTYPE=1 for an ISDN physical line.

SPOLL on the PU definition statement defines the frequency at which LMI full status requests are sent to the adjacent ISDN node over the associated ISDN B-channels by the LMI support. SPOLL is not valid if you specify LMI=NO for the link-station support.

TIMERS on the PU definition statement defines the LMI T391 and T392 intervals. The T391 interval is the interval between transmissions of LMI Link Integrity Verification (LIV) status enquiry messages to the adjacent node. The T392 interval is the interval in which an LMI status enquiry message must be received before the interval is considered an error interval. Code TIMERS and ERRORT on the PU definition statement for the link-station support to monitor the integrity of the ISDN B-channels associated with the physical line. TIMERS is not valid if you specify LMI=NO for the link-station support.

XMONLNK on the PU definition statement specifies whether the SMMF is to initially activate the physical line. If you code XMONLNK=NO, VTAM must activate it. Code XMONLNK=YES for remote loading.

## Defining ISDN B-Channels

### NDF-Added Keywords for ISDN Physical Lines (D-Channels)

When you define ISDN D-channels, NDF adds the following keywords to your generation definition if you do not code them.

```
GROUP DIAL=NO,  
      LNCTL=SDLC,  
      PUDR=NO,  
      PUTYPE=1,  
      SPEED=2048000  
PU    ADDR=01  
      INNPORT=YES,
```

Figure 7-2. NDF-Added Keywords for ISDN D-Channels

### Sample Definition of an ISDN Physical Line (D-Channel)

Figure 7-3 shows how to define an ISDN D-channel with a relative line number of 2176 and a port number of 9.

```
*****  
* ISDN PHYSICAL LINE 2176 *  
*****  
PHYSG  GROUP  DIAL=NO,ISDN=PHYSICAL  
PHYSL  LINE   ADDRESS=2176,PORTADD=9,ISDNLPN=913435363835  
PHYSPU PU     PUTYPE=1
```

Figure 7-3. Example: Defining an ISDN Physical Line (D-Channel)

---

## Defining ISDN B-Channels

The ISDN B-channel carries user data in an ISDN. You define an ISDN B-channel differently from an ISDN D-channel, because B-channels are logical entities representing time slots on an ISDN physical line. Define ISDN B-channels as single-point switched lines to enable flexible and dynamic ISDN connections. Define an ISDN B-channel with a single PU definition statement, which represents the local management interface (LMI) connection to the adjacent node. Do not specify LU definition statements under this PU definition statement.

The link-station support on each ISDN physical line (the first physical unit defined on the physical line) can use the LMI protocol to exchange line status information with adjacent nodes. When you define this capability for the link-station support, it is called the *LMI subport*. When a PVC status request is received from an adjacent node, the LMI subport provides information about PVCs that have been added or deleted, and indicates whether existing PVCs are currently active. For more information on the LMI protocol, refer to *NCP and EP Reference*.

Code the following definition statements and keywords to define ISDN B-channels.

GROUP	DIAL ISDN PHYSRSC
LINE	ADDRESS AUTOCOPY CALL ID NPACOLL SPEED
PU	ANS INNPORT PUTYPE XMONLNK

### GROUP

DIAL on the GROUP definition statement specifies whether the lines in the group require switched line control procedures. Code DIAL=YES when you define ISDN B-channels.

ISDN on the GROUP definition statement specifies the type of ISDN line. Code ISDN=(LOGICAL,B) when you define ISDN B-channels.

PHYSRSC on the GROUP definition statement associates the ISDN B-channels in the group with the link station for a particular physical line. Code PHYSRSC=*name*, where *name* is the name of the D-channel PU definition statement.

### LINE

ADDRESS on the LINE definition statement specifies the relative line number of the physical line as if the ISDN B-channel represents a real physical line. Code an address in the range of reserved addresses following the address of the ISDN physical line.

AUTOCOPY on the LINE definition statement specifies the number of copies to be made of the specified B-channel and its devices. You can use AUTOCOPY to create all the ISDN B-channel definitions for a D-channel without having to specifically code them.

CALL on the LINE definition statement specifies whether this line is to be used for incoming calls, outgoing calls, or both. CALL is valid only if you specify DIAL=YES on the GROUP definition statement. You can specify CALL=IN or CALL=INOUT; CALL=OUT does not apply to ISDN B-channels.

ID on the LINE definition statement specifies the exchange identification (XID) data that NCP builds to identify the station. If a corresponding VTAM switched major node PU definition exists, be sure ID corresponds to the IDNUM and IDBLK keywords in that definition. Read *VTAM Resource Definition Reference* for information about coding VTAM switched major nodes. You can also use the VTAM Configuration Services XID exit routine to provide VTAM with information to create a dynamic representation of the station. See *VTAM Customization* for more information about the exit.

## Defining ISDN B-Channels

If you specify the AUTOCOPY keyword, remember that NCP increments the ID value by one for each subsequent ISDN B-channel LINE definition statement.

NPACOLL on the LINE definition statement specifies whether the network performance analyzer is to collect performance data for the line. ISDN physical lines and stations use extended format COLLECT request/response units; therefore, if EXT is not coded, NDF adds it.

SPEED on the LINE definition statement sets the data rate for a line. SPEED also provides a value for NPM to use when computing line utilization statistics. Code SPEED=64000. If SPEED=64000 is not coded, NDF adds it.

### PU

ANS on the PU definition statement specifies whether the ISDN B-channel is to stop or continue to operate when NCP enters automatic network shutdown (ANS). Code ANS=CONTINUE. An ISDN B-channel might still shutdown during ANS if ANS shuts down all the logical stations associated with the ISDN B-channel.

INNPORT on the PU definition statement specifies whether an ISDN B-channel will remain active when CDLINK=ACT is specified on either the HALT or VARY INACT commands. Code INNPORT=YES. If INNPORT=YES is not coded, NDF adds it.

PUTYPE specifies the type of physical unit being defined. Code PUTYPE=1 for an ISDN B-channel.

XMONLNK on the PU definition statement specifies whether the SMMF is to initially activate the ISDN B-channel and link station. If you code XMONLNK=NO, VTAM must activate it. Code XMONLNK=YES for remote loading.

## NDF-Added Keywords for ISDN B-Channels

When you define ISDN B-channels, NDF adds the following keywords to your generation definition if you do not code them.

```
GROUP DIAL=YES,  
      LNCTL=SDLC,  
      NPACOLL=(YES,EXTENDED),1  
      PUTYPE=1,  
      SPEED=64000  
PU    INNPORT=YES,  
  
1 Added if NPA=YES on the BUILD definition statement.
```

Figure 7-4. NDF-Added Keywords for ISDN B-Channels

## Sample Definition of an ISDN B-Channel

Figure 7-5 on page 7-13 shows how to define two ISDN B-channels for incoming calls.

```

*****
* ISDN B-Channel 2177                                     *
*****
CHANL1 LINE ADDRESS=2177, CALL=IN, ID=00123456
CHANPU1 PU PUTYPE=1
*****
* ISDN B-Channel 2178                                     *
*****
*
CHANL2 LINE ADDRESS=2178, CALL=IN, ID=00234567
CHANPU2 PU PUTYPE=1

```

Figure 7-5. Example: Defining ISDN B-Channels

---

## Defining ISDN Logical Lines

This section describes:

- Defining ISDN logical subarea lines
- Defining ISDN logical peripheral lines
- Defining device addresses to VTAM

## Defining ISDN Logical Subarea Lines

Data can be multiplexed with frame-relay protocols over ISDN B-channels defined as ISDN logical subarea lines. An ISDN logical subarea line is a frame-relay PVC between TESP's in two NCP's, or a connection from NCP to VTAM, or NCP to any number of nodes, if one is a PU type 4 or type 5 node.

Code the following definition statements and keywords to define ISDN logical subarea lines.

## Defining ISDN Logical Lines

BUILD	OWNERPL <sup>1</sup>
SDLCST	GROUP MODE RETRIES
PATH	ER <sub>n</sub>
GROUP	ACTIVTO MODE
GROUP	AUTOGEN DIAL ISDN LINEAUT PHYSRSC PUTYPE
LINE	ADDRESS AUTOCOPY IPL MLTGPRI MONLINK NPACOLL RETRIES SDLCST T1TIMER T2TIMER
PU	BLOCK BRKCON COMRATE NETID PIUCHECK <sup>2</sup>

<sup>1</sup> Supported starting with NCP V7R6.  
<sup>2</sup> Supported starting with NCP V7R7.

### BUILD

OWNERPL on the BUILD definition statement specifies whether unassigned logical ISDN resources will be managed in owner-based pools. See “Unassigned Logical Line Pools” on page 7-22 for more information.

### SDLCST

GROUP on the SDLCST definition statement identifies the stand-alone GROUP definition statement that defines the characteristics of the subarea link.

MODE specifies whether the subarea link characteristics defined by this SDLCST definition statement are to be used when NCP is in a primary or secondary state.

RETRIES specifies how many attempts NCP is to make to recover from errors occurring during transmission over the subarea link.

### PATH

ER*n* on the PATH definition statement defines various characteristics of an explicit route between two subareas. The first suboperand identifies the adjacent subarea along the explicit route.

For ISDN subarea links, you need to code two types of GROUP definition statements:

1. Code one or more stand-alone GROUP definition statements to define characteristics of the link when NCP is in primary or secondary mode.
2. Code one or more GROUP definition statements to define groups of logical lines.

### GROUP

ACTIVTO on the GROUP definition statement specifies the length of time the secondary NCP is to wait for communication with the primary NCP before breaking the connection.

MODE on the GROUP definition statement specifies whether the link characteristics defined by this stand-alone GROUP definition statement are to be used when NCP is in a primary or secondary state.

### GROUP

AUTOGEN on the GROUP definition statement specifies how many LINE and PU definition statement pairs are to be automatically generated under the GROUP definition statement.

DIAL on the GROUP definition statement specifies whether the lines in the group require switched line control procedures. Code DIAL=YES when you define ISDN logical subarea lines.

ISDN on the GROUP definition statement specifies the type of ISDN line. Code ISDN=(LOGICAL,SUB) when you define ISDN logical subarea lines.

LINEAUT on the GROUP definition statement specifies automatic calling for a line group for which no physical address interface is defined. Code LINEAUT=YES for ISDN logical subarea lines; if you do not code LINEAUT, NDF adds it.

PHYSRSC on the GROUP definition statement associates the logical lines in a group with the link station for a particular physical line. You must code PHYSRSC=NONE or PHYSRSC=(NONE,ODLC). This specification defines a pool of ISDN logical lines. See "Unassigned Logical Line Pools" on page 7-22 for more information.

PUTYPE specifies the type of physical unit being defined. Code PUTYPE=4 for an ISDN logical subarea line.

### LINE

ADDRESS on the LINE definition statement specifies the relative line number of a physical line. You must code ADDRESS=NONE for logical lines.

AUTOCOPY on the LINE definition statement specifies the number of copies to be made of the logical subarea line.

IPL specifies whether an NCP can be loaded or dumped over this link. Code IPL=YES to load a remote NCP over an ISDN subarea link. See "Remote Loading and Activation over an ISDN Line" on page 7-32 for more information.

## Defining ISDN Logical Lines

MLTGPRI assigns a priority to each line in an MLTG. Code MLTGPRI only when you define an ISDN line in an MLTG.

MONLINK specifies whether NCP is to include the SSCP monitor mode function (SMMF) for type 4 physical units attached to subarea links. If you code MONLINK=YES for an ISDN subarea link, also code XMONLNK=YES on the PU definition statement for an ISDN B-channel and its D-channel. If you code MONLINK only, the link activation will fail.

NPACOLL specifies whether the link is to be eligible for NPM performance data collection. ISDN logical lines use extended format COLLECT request/response units.

RETRIES specifies how many attempts NCP is to make to recover from errors that occur during transmission over an ISDN logical subarea line.

SDLCST identifies the names of SDLCST definition statements that define the values used for MAXOUT and RETRIES when NCP is in a primary or a secondary state. See "Defining Configurable Point-to-Point Subarea Links" on page 12-8 for more information about how to define NCP to operate in a primary or a secondary state.

T1TIMER specifies the T1 (reply) timer interval for a local link. It is important to code a value for T1TIMER that reflects the maximum amount of time that it takes to receive a solicited response from the adjacent link station. Factors that can affect this time include line speed, propagation delay, maximum frame size, and the number of DLCIs supported by the associated physical line that could create queuing delays for the FRTEs. If the value you code for T1TIMER is too small, the FRTEs can lose synchronization and fail the connection. This is indicated by an INOP 01 and a link event or an alert that indicates a frame reject (FRMR) condition. If this occurs, code a larger T1TIMER value for this FRTE connection.

T2TIMER specifies the acknowledgment (T2) timer interval and I-frame count for this resource. NCP sends an acknowledgment when the T2 timer interval expires or when the number of I-frames received reaches the I-frame count, whichever occurs first.

## PU

BLOCK on the PU definition statement specifies the maximum frame size and the maximum number of PIUs per frame. The value of BLOCK must not exceed the value of MAXFRAME for the physical line. See page 24-7 for more information on the BLOCK keyword.

BRKCON on the PU definition statement specifies the circumstances when an ISDN subarea connection is broken (an activity timeout). A timeout can occur if, during the time defined by ACTIVTO on the GROUP statement, no information frames were sent or received by the line. BRKCON can specify that an activity timeout starts when the two stations establish a connection or when NCP goes into ANS. BRKCON can also prevent a connection break on an ISDN line.

COMRATE on the PU definition statement specifies whether certain frames can be discarded by a frame-relay network (with the first suboperand) and specifies the relative priority of stations (with the second suboperand). In a pure ISDN environment, the first suboperand does not have any effect on throughput because the ISDN provides dedicated bandwidth for the B-channel connections. However, if



part of the connection crosses a frame-relay network, for example, one of the DTEs is an FRTE, the suboperand setting might have an effect on which frames the frame-relay network discards during congestion. You can use the second suboperand to specify the relative priority among ISDN stations associated with an ISDN port.

Frames in an ISDN can be designated as *discard eligible*. When the network is congested, discard-eligible frames can be discarded to expedite the processing of other frames. Code `COMRATE=FULL` to specify that no frames are to be designated as discard eligible. Code `COMRATE=NONE` to cause NCP to designate all but the following frame types as discard eligible:

- S-frames (RR, RNR, and REJ), including RRs piggybacked on I-frames
- Network priority frames (VR pacing and TG sweep)
- XIDs.

To ensure equitable treatment of all traffic in the ISDN, choose a value for `COMRATE` such that NCP is consistent with the rest of the network in the use of discard-eligible frames.

The *priority* suboperand (coded as `COMRATE=(FULL,priority)` or `COMRATE=(NONE,priority)`) specifies a relative priority of an FRTE station. The value of the *priority* suboperand of `COMRATE` is multiplied by the value of `DATABLK` on the `LINE` definition statement for the physical line to determine the maximum number of bytes that a resource can transmit before a different resource must be given a transmit opportunity.

The relative priority of an ISDN station can be determined by the fraction of the total available transmission time on a line that a station gets. This fraction is calculated by dividing the station's `COMRATE priority` value by the sum of the `COMRATE priority` values for all stations on the line:

$$\frac{\text{PU1's } priority \text{ value}}{\text{The sum of } priority \text{ values of all PUs on or associated with the physical line}}$$

For example, if there are three PUs for a line, PU1's transmission fraction is determined like this:

$$\frac{PRIORITY_{PU1}}{PRIORITY_{PU1} + PRIORITY_{PU2} + PRIORITY_{PU3}}$$

Where `PRIORITY` = the value of the respective PU's *priority* suboperand of the `COMRATE` keyword.

`NETID` on the PU definition statement specifies the name of the network containing the adjacent subarea node.

`PIUCHECK` specifies whether a checksum validation should be performed on PIUs sent and received by this station. For the checksum validation support to be enabled, the adjacent link station must also have `PIUCHECK=YES` coded. For more information about the `PIUCHECK` subarea checksum support, see `PIUCHECK` keyword on the PU definition statement on page 24-9.

## Defining ISDN Logical Lines

### NDF-Added Keywords for ISDN Logical Subarea Lines

When you define ISDN logical subarea lines, NDF adds the following keywords to your generation definition if you do not code them.

```
GROUP DIAL=YES,  
      LINEAUT=YES,  
      LNCTL=SDLC,  
      NPACOLL=(YES,EXTENDED), 1  
      PUTYPE=4,  
  
1 Added if NPA=YES on the BUILD definition statement.
```

Figure 7-6. NDF-Added Keywords for ISDN Logical Subarea Lines

### Sample Definition of an ISDN Subarea Link

Figure 7-7 shows how to define a pool of ISDN logical subarea lines.

```
*****  
* ISDN LOGICAL SUBAREA LINE GROUP *  
*****  
LOGIIG GROUP DIAL=YES,ISDN=(LOGICAL,SUB),PHYSRSC=NONE,PUTYPE=4,  
          SDLCST=(PRIST,SECST)  
LOGIIL LINE ADDRESS=NONE  
LOGIIP PU SA TESP PU
```

Figure 7-7. Example: Defining an ISDN Subarea Link

### Defining ISDN Logical Peripheral Lines

An ISDN logical peripheral line is a frame-relay PVC between a TESP in an NCP 3746 Model 900 and a TESP in a peripheral device.

Code the following definition statements and keywords to define ISDN peripheral links.

BUILD	OWNERPL <sup>1</sup>
GROUP	AUTOGEN DIAL ISDN LINEAUT PHYSRSC
LINE	AUTOCOPY NPACOLL RETRIES T1TIMER T2TIMER
PU	COMRATE PUTYPE
<sup>1</sup> Supported starting with NCP V7R6.	

**BUILD**

OWNERPL on the BUILD definition statement specifies whether unassigned logical ISDN resources will be managed in owner-based pools. See “Unassigned Logical Line Pools” on page 7-22 for more information.

**GROUP**

AUTOGEN on the GROUP definition statement specifies how many LINE and PU definition statement pairs are to be automatically generated under the GROUP definition statement.

DIAL on the GROUP definition statement specifies whether the lines in the group require switched line control procedures. Code DIAL=YES when you define ISDN logical peripheral lines.

ISDN on the GROUP definition statement specifies the type of ISDN line. Code ISDN=(LOGICAL,PER) when you define ISDN logical peripheral lines.

LINEAUT on the GROUP definition statement specifies automatic calling for a line group for which no physical address interface is defined. Code LINEAUT=YES for ISDN logical peripheral lines; if you do not code LINEAUT, NDF adds it.

PHYSRSC on the GROUP definition statement associates the logical lines in a group with the link station for a particular physical line. You must code PHYSRSC=NONE or PHYSRSC=(NONE,ODLC). This specification defines a pool of ISDN logical lines. See “Unassigned Logical Line Pools” on page 7-22 for more information.

**LINE**

AUTOCOPY on the LINE definition statement specifies the number of copies to be made of the logical peripheral line.

NPACOLL on the LINE definition statement specifies whether the network performance analyzer is to collect performance data for the line. ISDN logical lines use extended format COLLECT request/response units; therefore, if EXT is not coded, NDF adds it.

## Defining ISDN Logical Lines

RETRIES on the LINE definition statement specifies how many attempts NCP is to make to recover from errors that occur during transmission over a link.

T1TIMER specifies the T1 (reply) timer interval for a local link. It is important to code a value for T1TIMER that reflects the maximum amount of time that it takes to receive a solicited response from the adjacent link station. Factors that can affect this time include line speed, propagation delay, maximum frame size, and the number of DLCIs supported by the associated physical line that could create queuing delays for the FRTEs. If the value you code for T1TIMER is too small, the FRTEs can lose synchronization and fail the connection. This is indicated by an INOP 01 and a link event or an alert that indicates a frame reject (FRMR) condition. If this occurs, code a larger T1TIMER value for this FRTE connection.

T2TIMER specifies the acknowledgment (T2) timer interval and I-frame count for this resource. NCP sends an acknowledgment when the T2 timer interval expires or when the number of I-frames received reaches the I-frame count, whichever occurs first.

## PU

Code one PU definition statement to define the TESP for the peripheral link.

COMRATE on the PU definition statement specifies whether certain frames can be discarded by a frame-relay network (with the first suboperand) and specifies the relative priority of stations (with the second suboperand). In a pure ISDN environment, the first suboperand does not have any effect on throughput because the ISDN provides dedicated bandwidth for the B-channel connections. However, if part of the connection crosses a frame-relay network, for example one of the DTEs is an FRTE, the suboperand setting might have an effect on which frames the frame-relay network discards during congestion. You can use the second suboperand to specify the relative priority among ISDN stations associated with an ISDN port.

Frames in an ISDN can be designated as *discard eligible*. When the network is congested, discard-eligible frames can be discarded to expedite the processing of other frames. Code COMRATE=FULL to specify that no frames are to be designated as discard eligible. Code COMRATE=NONE to cause NCP to designate all but the following frame types as discard eligible:

- S-frames (RR, RNR, and REJ), including RRs piggybacked on I-frames
- Network priority frames (VR pacing and TG sweep)
- XIDs.

To ensure equitable treatment of all traffic in the ISDN, choose a value for COMRATE such that NCP is consistent with the rest of the network in the use of discard-eligible frames.

The *priority* suboperand (coded as COMRATE=(FULL,*priority*) or COMRATE=(NONE,*priority*)) specifies a relative priority of an FRTE station. The value of the *priority* suboperand of COMRATE is multiplied by the value of DATBLK on the LINE definition statement for the physical line to determine the maximum number of bytes that a resource can transmit before a different resource must be given a transmit opportunity.

The relative priority of an ISDN station can be determined by the fraction of the total available transmission time on a line that a station gets. This fraction is calcu-

lated by dividing the station's COMRATE *priority* value by the sum of the COMRATE *priority* values for all stations on the line:

$$\frac{\text{PU1's } \textit{priority} \text{ value}}{\text{The sum of } \textit{priority} \text{ values of all PUs on or associated with the physical line}}$$

For example, if there are three PUs for a line, PU1's transmission fraction is determined like this:

$$\frac{\text{PRIORITY}_{\text{PU1}}}{\text{PRIORITY}_{\text{PU1}} + \text{PRIORITY}_{\text{PU2}} + \text{PRIORITY}_{\text{PU3}}}$$

Where PRIORITY = the value of the respective PU's *priority* suboperand of the COMRATE keyword.

PUTYPE specifies the type of physical unit being defined. Code PUTYPE=2 for a peripheral link.

### NDF-Added Keywords for ISDN Logical Peripheral Lines

When you define ISDN logical peripheral lines, NDF adds the following keywords to your generation definition if you do not code them.

```

GROUP DIAL=YES,
      LINEAUT=YES,
      LNCTL=SDLC,
      NPACOLL=(YES,EXTENDED), 1
      PUTYPE=2,
1 Added if NPA=YES on the BUILD definition statement.
    
```

Figure 7-8. NDF-Added Keywords for ISDN Logical Peripheral Lines

### Sample Definition of a ISDN Peripheral Link

Figure 7-9 shows how to define a pool of logical peripheral lines.

```

*****
* ISDN LOGICAL PERIPHERAL LINE GROUP *
*****
LOGIBG GROUP DIAL=YES,ISDN=(LOGICAL,PER),PHYSRSC=NONE
LOGIBL1 LINE ADDRESS=NONE
LOGIBP1 PU PUTYPE=2 PN TESP
LOGIBL2 LINE ADDRESS=NONE
LOGIBP2 PU PUTYPE=2 PN TESP
    
```

Figure 7-9. Example: Defining an ISDN Peripheral Link

### Unassigned Logical Line Pools

ISDN subarea and peripheral logical resources are managed as unassigned logical line pools. `PHYSRSC=(NONE,ODLC)` is required for ISDN logical subarea and peripheral resources.

#### Allocating Unassigned Logical Line Pools to Owners

In a multiple-owner environment (for example, dual CMCs), it might be advantageous to have multiple unassigned logical line pools that are based on the owning SSCP. To do this, you must:

1. Allocate each physical line to a specific owner by coding the VTAM-only `OWNER` keyword for each physical line with one and only one *owner\_name*.
2. Allocate each logical pool to a specific owner by coding the VTAM-only `OWNER` keyword for each logical pool.
3. Code the `OWNERPL` keyword on the `BUILD` statement.

This function will control call-in connections. An unassigned logical resource will be used for an incoming call only if the logical resource has the same owning SSCP as the physical line over which the call was made. If there are no logical resources available with the same owning SSCP, an incoming call cannot be established.

To create the owner-based unassigned logical pools for ISDN resources, code `OWNERPL=ISDN`.

### Defining Device Addresses to VTAM

You can establish ISDN connections as dial-in or dial-out connections from a device to VTAM. Establishing a dial-out connection is not necessary for B-channel connections. NCP will automatically connect the B-channel when a dial-out or dial-in connection occurs for the logical line. Therefore, you do not have to code dial information for the B-channel. Instead, the necessary B-channel dial information is coded on the logical line.

When you are defining to VTAM a switched major node that uses an ISDN logical line, if the connection to the ISDN device will be initiated by VTAM, you need to specify dial information to enable VTAM to initiate the connection. You can specify the information with the `DLCADDR` keyword on the VTAM `PATH` definition statement.

When you specify dial information to VTAM, you can override some of the values specified by the NCP definition statements or their defaults. For example, the `ISDNLSA` keyword on the physical line's `PU` or `LINE` definition statement can be overridden by specifying the value on the `DLCADDR` keyword for the logical line.

#### VTAM `DLCADDR` keyword

A data link control (DLC) address for an SNA resource has elements that describe the logical line.

Element	Element Indicator Description
1	DLC type
2	Port number

- 3 Destination service access point (DSAP)
- 4 DLCI of the frame-relay PVC
- 5 Source service access point (SSAP) (optional)
- 6 Destination MAC address (if BAN-attached).

An ISDN data link control (DLC) address for an SNA resource also has ISDN-related elements that describe the ISDN B-channel characteristics.

**Element**

	Indicator	<b>Element</b> Description
7		LMI standard (optional)
1		DLC signaling type
2		Port identifier

ISDN-related elements also define connection information.

**Element**

	Indicator	<b>Element</b> Description
21		Remote party number
22		Local party number (optional)
23		Remote party subaddress (optional)
24		Local party subaddress (optional)

Code a DLCADDR keyword for each element.

For the DLCADDR keyword value:

- The first suboperand indicates which element you are defining.
- The second suboperand indicates the format of the third suboperand (C=character, D=decimal, and X=hexadecimal).
- The third suboperand defines the value of the element.

Code the DLCADDR keyword as follows:

1. To specify a DLC type of frame relay, code:

DLCADDR=(1,C,FRPVC)

2. To identify the port number of the ISDN physical line over which the logical connection is made, code:

DLCADDR=(2,D,*nn*)

where *nn* is the decimal number corresponding to the value you code for PORTADD on the LINE definition statement. This value should be the same as the port identifier element that you code on the DLCADDR statement to describe the B-channel.

3. To specify the DSAP, code:

DLCADDR=(3,D,*nn*)    or    DLCADDR=(3,X,*hh*)

## Defining ISDN Logical Lines

where *nn* and *hh* are the SAP of the remote data terminating equipment (DTE), in decimal and hexadecimal, respectively. The value must be even and in the range of X'02' to X'0FE'.

4. To specify the DLCI of the frame-relay PVC, code:

DLCADDR=(4,D,*nnn*) or DLCADDR=(4,X,*hhh*)

where *nnn* and *hhh* are the DLCI of the remote ISDN device, in decimal and hexadecimal, respectively. The value must be in the range of 16 to 991.

For subarea resources, the DLCIs must be unique for each logical line defined for the same B-channel. For peripheral resources, you can multiplex DLCIs. You can define multiple logical peripheral resources on the same B-channels with the same DLCI and specify different DSAPs.

5. To specify the SSAP, code:

DLCADDR=(5,D,*nn*) or DLCADDR=(5,X,*hh*)

where *nn* and *hh* are the SAP of the source NCP, in decimal and hexadecimal, respectively. Specifying this element is optional. If you do not specify a value, NCP uses a value of 04. If you specify the SSAP, you must specify a SAP of 04 for NCP dial processing.

6. To specify the destination MAC address for BAN, code:

DLCADDR=(6,X,*hhhhhhhhhhhh*)

where *hhhhhhhhhhhh* is the destination MAC address of the BAN-attached peripheral device on the LAN that connects it to the remote BAN router. This element is required only when you are defining a BAN connection.

You can code the full range of DSAPs for each BAN MAC address.

7. To specify the frame-relay local management interface (LMI) protocol standard, code:

DLCADDR=(7,X,*hh*)

where *hh* is:

X'00' for no standard

X'40' for the ANSI standard

X'48' for ANSI-NUI (ANSI with Network-to-User Interface)

X'80' for the CCITT (ITU-T) standard

X'88' for CCITT-NUI (ITU-T with Network-to-User Interface)

Specifying this element is optional. If you do not specify a value, NCP uses the coded value or default in the NCP generation definition.

8. To specify the DLC signaling type, code:

DLCADDR=(1,C,ISDNSW)

9. To specify the port identifier of the ISDN physical line over which the connection is made, code:

DLCADDR=(2,D,*nn*)

where *nn* is the decimal number corresponding to the value you code for PORTADD on the LINE definition statement. This value should be the same as the port number element that you code on the DLCADDR statement to describe the logical line.

10. To specify the remote party number, code:



DLCADDR=(21,X,tn3d3d3d3d3d3d3d)

where:

- t* is the type of number
- n* is the numbering plan identification
- d* is a decimal digit of the called party number

For a dial-out connection, the remote party number is the address of the remote DTE (called party).

The remote party number must be defined according to the ITU-T Q.931 recommendation. See the description of the ISDNRPN keyword in the *NCP, SSP, and EP Resource Definition Reference* for more information about the format.

11. To specify the local party number, code:

DLCADDR=(22,X,t<sup>n</sup>ps3d3d3d3d3d3d3d)

where:

- t* is the type of number
- n* is the numbering plan identification
- p* is the optional presentation indicator
- s* is the optional screen indicator
- d* is a decimal digit of the calling party number

For a dial-out connection, the local party number is the address of the local DTE (calling party). This element is optional. If you do not specify a value, NCP uses the coded ISDNLPN keyword value, if present, in the NCP generation definition. The local party number must be defined according to the ITU-T Q.931 recommendation. See the description of the ISDNLPN keyword in the *NCP, SSP, and EP Resource Definition Reference* for more information about the format.

12. To specify the remote party subaddress, code:

DLCADDR=(23,X,tpdd)

where:

- t* is the type of subaddress
- p* is the odd or even indicator
- d* is a decimal digit of the subaddress

For a dial-out connection, the remote party subaddress is the subaddress of the remote DTE (called party).

This element is optional but there is no default. If the called party requires this value, it must be specified.

The remote party subaddress must be defined according to the ITU-T Q.931 recommendation. See the description of the ISDNRSA keyword in the *NCP, SSP, and EP Resource Definition Reference* for more information about the format.

13. To specify the local party subaddress, code:

DLCADDR=(24,X,tpdd)

where *tpdd* is the local DTE subaddress, where:

*t* is the type of subaddress  
*p* is the odd or even indicator  
*d* is a decimal digit of the subaddress

For a dial-out connection, the local party subaddress is the subaddress of the local DTE (calling party).

This element is optional. If you do not specify a value, NCP uses the coded ISDNLSA keyword value, if present, in the NCP generation definition.

The local party subaddress must be defined according to the ITU-T Q.931 recommendation. See the description of the ISDNLSA keyword in the *NCP, SSP, and EP Resource Definition Reference* for more information about the format.

For example, suppose you need to make outgoing connections to an ISDN peripheral device using a frame-relay PVC with a DLCI of X'32' and a DSAP of 4. The ISDN physical line supporting the PVC is identified by port number 9, the physical address is 118039313932353435363132, and the subaddress is A001. The address of the party that you are calling is 9139313932353435363835, and its subaddress is A08F.

To specify this information using the DLCADDR keyword, code:

DLCADDR=(1,C,FRPVC),	Frame Relay protocol
DLCADDR=(2,D,9),	Port address of physical line
DLCADDR=(3,D,4),	DSAP 4
DLCADDR=(4,X,32)	DLCI of PVC (X'32')
DLCADDR=(7,X,40)	LMI=ANSI
DLCADDR=(1,C,ISDNSW),	ISDN switched protocol
DLCADDR=(2,D,9),	Port address of physical line
DLCADDR=(21,X,9139313932353435363835),	Remote DTE address
DLCADDR=(22,X,118039313932353435363132),	Local DTE address
DLCADDR=(23,X,A08F),	Remote DTE subaddress
DLCADDR=(24,X,A001),	Local DTE subaddress

For more information on the VTAM PATH definition statement and DLCADDR keyword, refer to *VTAM Resource Definition Reference*.

---

## Establishing a Connection

The ISDN information coded in NCP and VTAM definitions enable you to establish and receive calls. To establish a connection, a calling (local) party specifies the ISDN number or the ISDN number and subaddress of the called (remote) party in VTAM DLCADDR keyword elements. To receive ISDN calls, the ISDNLSA (local subaddress) keyword or the ISDNLPN (local party number) keyword must be coded on the ISDN physical LINE definition statement. The subaddresses are checked if the called party subaddress is received in the incoming call setup; otherwise the ISDN number is checked. The specific criteria follow:

1. If a called (remote) subaddress is present in the incoming call setup:
  - a. If it is identical to the ISDNLSA (local subaddress) keyword coded on the ISDN physical line, the call is accepted.

- b. If the subaddresses are not identical, each frame-relay line that is eligible for backup over this ISDN line (if any) is checked. See “Defining Automatic Frame-Relay Backup over an ISDN” on page 16-22 for more information.
2. If the called (remote) subaddress is not present in the incoming setup:
  - a. If the called (remote) party number received in the incoming call setup is identical to the local party number specified with the ISDNLPN keyword, the call is accepted.
  - b. If the party numbers are not identical, each frame-relay line that is eligible for backup over this ISDN line (if any) is checked. See “Defining Automatic Frame-Relay Backup over an ISDN” on page 16-22 for more information.

Checking subaddresses is the preferred method, whenever possible, because ISDN networks always transparently carry the subaddress. On the other hand, ISDN networks can change the format of the ISDN number, for example, from a national to an international number. Also some networks (for example, the French Numeris VN4 network) can truncate the called party number to keep only the part it needs. If you intend to use the number based method, ask your service provider how the network delivers the called party number.

The following sections show examples of the information specified and checked for the subaddress and number methods.

**Subaddress method:** The calling party specifies the party number and subaddress of the remote party. The called party checks the subaddress in the incoming call setup with its local subaddress. Table 7-1 shows an example of values coded for the subaddress method:

*Table 7-1. Values Coded with the Subaddress Method*

Calling Party	Called Party
DLCADDR=(21,X,913031)	
DLCADDR=(23,X,A002)	ISDNLSA=A002

**Number method:** The calling party specifies the party number of the NCP that it wants to call. The called party checks the party number in the incoming call setup with its local party number. Table 7-2 shows an example of values coded for the number method.

*Table 7-2. Values Coded with the Number Method*

Calling NCP	Called NCP
DLCADDR=(21,X,913031)	ISDNLPN=913031

## Subscribing to the Network

When you subscribe the ISDN line to the network, you can request the following services:

- The supplementary subaddress service. If you use the subaddress method, you must subscribe to this service.
- The Calling Line Identification Presentation (CLIP) supplementary service. This service provides the called party with the calling party’s ISDN number and subaddress information. This service is recommended because this information might be needed to allow multiple sessions to share a B-channel connection from both DTEs.

- The Calling Line Identification Restriction (CLIR) supplementary service. This service prevents the called party from receiving the calling party's ISDN number and subaddress information.

## Controlling ISDN B-Channel Connections

NCP sets up ISDN B-channels based on the local (calling) party and the remote (called) party information that you supply when you establish dial-out connections. A B-channel is defined between two specific DTEs. Multiple connections between the DTEs can share the same B-channel or multiple B-channels can be set up between the same DTEs. Knowing the guidelines that NCP uses for establishing B-channels for outgoing calls can help you control the setup based on the VTAM DLCADDR element information that you provide.

When you define an ISDN D-channel with the NCP LINE statement, you must specify either the local party number (LPN) or the local subaddress (LSA). When you define a dial-out connection with VTAM DLCADDR elements, you must specify the remote party number (RPN) and, optionally, you can specify the remote subaddress (RSA). You can also override the local party number and the local party subaddress on the NCP LINE definition statement by specifying them in the VTAM DLCADDR elements.

The VTAM DLCADDR element information determines how NCP sets up the ISDN B-channel configuration. When the LPN and LSA (specified by a LINE statement or VTAM DLCADDR elements) and the RPN and RSA match an existing ISDN B-channel, NCP uses that existing B-channel; otherwise, NCP establishes a new B-channel. The following sections describe defining a physical line and some scenarios for setting up B-channel connections on that physical line.

**Defining a Physical Line:** An NCP LINE statement defines an ISDN D-channel. The LINE statement or VTAM DLCADDR elements can indicate the local party number (LPN) and local subaddress (LSA). When establishing a dial-out connection to a remote DTE, you define the remote party number (RPN) and remote subaddress (RSA) using VTAM DLCADDR elements.

In this example, the LINE statement defines D-channel Z with a local party number (LPN) of 913031 and local subaddress (LSA) of A002

```
PHYSL  LINE  ADDRESS=2176,PORTADD=9,ISDNLPN=913031,ISDNLSA=A002
```

Table 7-3 shows the ISDN calling information for D-channel Z:

Table 7-3. ISDN D-Channel Defined

Party Information	ISDN D Channel Z
Local Party Number (LPN)	913031
Local Subaddress (LSA)	A002
Remote Party Number (RPN)	
Remote Subaddress (RSA)	

**Defining B-Channels on the Physical Line:** To establish a connection to a remote DTE, DLCADDR keyword elements on a VTAM PATH statement can specify the party number and subaddress of the remote DTE. In this example, the DLCADDR elements specify an RPN of 913131 and RSA of A012 and the same LPN of 913031 and LSA of A002 as D-Channel Z:

DLCADDR=(21,X,913131), Remote party number (RPN)  
 DLCADDR=(22,X,913031), Local party number (LPN)  
 DLCADDR=(23,X,A012), Remote subaddress (RSA)  
 DLCADDR=(24,X,A002), Local subaddress (LSA)

NCP establishes an ISDN B-channel, which is called B-Channel 1 in this example, on D-Channel Z. B-Channel 1 is attached to an RPN of 913131 and RSA of A012 defined by the VTAM DLCADDR elements. Table 7-4 shows the ISDN calling information for B-channel 1:

Table 7-4. ISDN B-Channel Defined

Party Information	ISDN D Channel Z	ISDN B Channel 1
LPN	913031	913031
LSA	A002	A002
RPN		913131
RSA		A012

Other B-channel connections can be established on the physical line. If you do not specify the LPN and LSA when you establish a connection, NCP uses the local party number and subaddress of the physical line.

DLCADDR keyword elements on another VTAM PATH statement specify the same RPN of 913131 and RSA of A012 and do not specify an LPN or LSA:

DLCADDR=(21,X,913131), Remote party number (RPN)  
 DLCADDR=(23,X,A012), Remote subaddress (RSA)

NCP uses the existing B-Channel 1 path for the connection for the following reasons:

- NCP uses the LPN of 913031 and LSA of A002 specified on D-Channel Z LINE statement, because the LPN and LSA are not specified on the VTAM DLCADDR elements.
- The RPN of 913131 and RSA of A012 are the same as B-Channel 1.

The LPN, LSA, RPN, and RSA match ISDN B-Channel 1 so NCP uses that channel.

**Defining a B-Channel Based on an Incoming Call Setup:** When an incoming call request provides the calling party number and subaddress, a new B-channel is established. In this example, an incoming call request with a calling party number of 914444 and a calling party subaddress of A444 will result in a new B-channel, B-Channel 2. NCP uses the LPN and LSA of the physical line for the incoming call. Therefore, B-Channel 2 will have an LPN of 913031, an LSA of A002, an RPN of 914444, and an RSA of A444 as shown in Table 7-5

Table 7-5. ISDN B-Channel Defined Based on Incoming Call Setup

Party Information	ISDN D Channel Z	ISDN B Channel 1	ISDN B Channel 2
LPN	913031	913031	913031
LSA	A002	A002	A002
RPN		913131	914444
RSA		A012	A444

B-Channel 2 can be shared with an outgoing call. For example, NCP will use B-Channel 2 for a call that specifies the following VTAM DLCADDR elements:

```
DLCADDR=(21,X,914444),      Remote party number (RPN)
DLCADDR=(23,X,A444),       Remote subaddress (RSA)
```

**Defining a B-Channel to Another DTE:** To connect to another remote DTE, you can establish another B-channel on the same physical line. You would specify the remote party number and subaddress. If you do not specify the LPN and LSA when you establish a connection, NCP uses the local party number and subaddress of the physical line.

In this example, DLCADDR keyword elements on another VTAM PATH statement specify an RPN of 913232 and an RSA of A022 to call the DTE and do not specify an LPN or LSA:

```
DLCADDR=(21,X,913232),      Remote party number (RPN)
DLCADDR=(23,X,A022),       Remote subaddress (RSA)
```

NCP establishes a new ISDN B-channel, B-Channel 3, as shown in Table 7-6:

Table 7-6. ISDN B-Channel to Another DTE

Party Information	ISDN D Channel Z	ISDN B Channel 1	ISDN B Channel 2	ISDN B Channel 3
LPN	913031	913031	913031	913031
LSA	A002	A002	A002	A002
RPN		913131	914444	913232
RSA		A012	A444	A022

NCP uses the LPN of 913031 and LSA of A002 specified on D-Channel Z LINE statement, because the LPN and LSA are not specified on the VTAM DLCADDR elements.

**Defining a Different B-Channel to the Same DTE on the Physical Line:** You might want to define a different B-channel on the same DTE. For example, you might have two 64-Kbps leased lines (one for batch traffic and one for interactive transmission) that you want to replace with ISDN connections. You can have NCP set up two B-channels to the remote site, one for batch traffic and one for interactive transmission, even though the remote party number for both connections is the same.

You code the same RPN and RSA as B-Channel 3, because you are calling the same DTE. You indicate that you want a new B-channel by specifying a different local subaddress.

In this example, DLCADDR keyword elements on another VTAM PATH statement specify an RPN of 913232, an RSA of A022, an LPN of 913031, and a different LSA to establish a new B-channel to the same DTE.

```
DLCADDR=(21,X,913232),      Remote party number (RPN)
DLCADDR=(22,X,913031),      Local party number (LPN)
DLCADDR=(23,X,A022),       Remote subaddress (RSA)
DLCADDR=(24,X,A032),       Local subaddress (LSA)
```

NCP establishes a new B-channel, B-Channel 4, to the same DTE as B-Channel 3 by specifying a different LSA of A032 and the same LPN as D-Channel Z as shown in Table 7-7 on page 7-31:

Table 7-7. ISDN B-Channel to the Same DTE

Party Information	ISDN D Channel Z	ISDN B Channel 1	ISDN B Channel 2	ISDN B Channel 3	ISDN B Channel 4
LPN	913031	913031	913031	913031	913031
LSA	A002	A002	A002	A002	A032
RPN		913131	914444	913232	913232
RSA		A012	A444	A022	A022

Reliable B-channel sharing of an additional B-channel connection (achieved by specifying a different LSA in the DLCADDR element than the one coded on the ISDNLSA keyword) can only be done by the NCP that established the dial-out connection.

## Defining ISDN Subarea Connectivity through a Terminal Adapter or BAN Device

This section explains how to establish connections like those shown in Figure 7-10 and Figure 7-11.

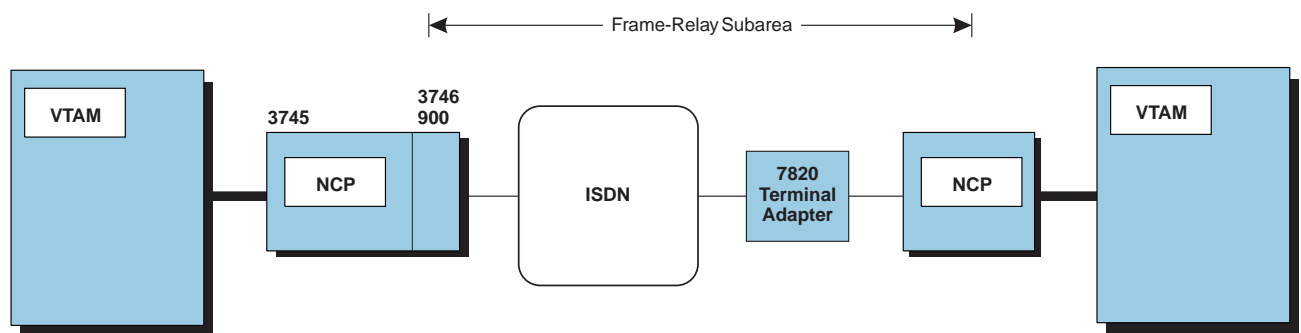

Figure 7-10. Example of a Frame-Relay/ISDN Subarea Connection through a Terminal Adapter

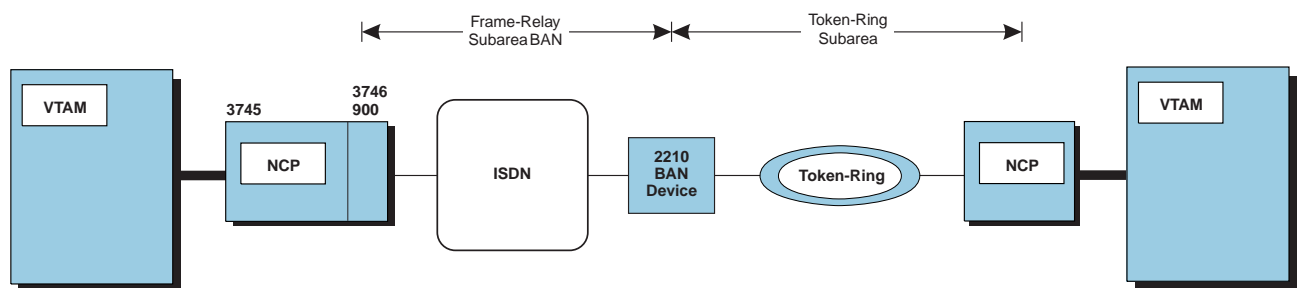

Figure 7-11. Example of a Token-Ring/ISDN Subarea Connection through a BAN Device

In each figure, the left side of the diagram is a switched subarea, and the right side of the diagram is a nonswitched subarea.

The following restrictions apply:

- The NCP on the nonswitched side must be NCP V5R4 or later.
- Remote loading and activation from the nonswitched side to the switched side is not supported.

## Special Configurations

- Remote loading and activation from the switched side to the nonswitched side is supported, except for the case where the nonswitched side of the connection is a 3746 Model 900 frame-relay connection.
- Call security verification, as specified by the PRTCT keyword on the PU statement in the VTAM switched major node definition, is not supported.

For either of these configurations to work, the TGN and IDNUM keyword values must be coded as follows:

- TGN** A specific TG number must be coded when defining the logical PU in the NCP gen on the nonswitched side, and that same TGN or TGN=ANY must be coded when defining the logical PU in the VTAM switched major node definition on the switched side.
- IDNUM** For the switched PU, IDNUM must be coded on the PU statement in the VTAM switched major node definition. IDNUM is not coded for non-switched PUs. IDNUM must be specified as a hexadecimal number consisting of the TGN (converted to hexadecimal) followed by a counter value from X'0' to X'F'.

For example, in Figure 7-10 on page 7-31 if there is one subarea connection between the two NCPs, and the TGN is decimal 25, the IDNUM would be defined by converting the TGN to hexadecimal, X'19', then adding a counter value. Because only one connection is defined between the two subareas, the counter value is X'0'. Therefore, the IDNUM is X'190'.

Using the same figure, if there are multiple subarea connections between the two NCPs with the same TGN (that is, if multilink TGs are defined), the IDNUM for the first PU statement is X'190'. The counter value is then incremented for each subsequent PU statement. That is, the IDNUM for the next PU statement would be X'191', then X'192', up to X'19F' if 16 links were defined in the MLTG. The counter value must always start at X'0' and be incremented for each subsequent PU statement with the same TGN between the same two subareas.

Again in Figure 7-10 on page 7-31, suppose that three connections are defined between the two NCPs, with three different TGNs. The first TGN is 7; the second TGN is 3; and the third TGN is 25. The IDNUMs should be X'70' for the first connection, X'30' for the second connection, and X'190' for the third connection. Because the TGNs are all different, the counter value in each IDNUM is X'0'.

---

## Remote Loading and Activation over an ISDN Line

You can use an ISDN subarea link to load an NCP load module into a remote communication controller containing an active NCP, and then activate the new NCP through SMMF. To do this, the active NCP in the remote controller must include an ISDN subarea link defined with:

- XMONLNK=YES on the PU definition statement for the physical line and any ISDN B-channel associated with the physical line
- IPL=YES and MONLINK=YES on the LINE definition statement for the logical subarea line.

The ISDN subarea link definition also includes:



## Coding ISDN Definitions for the Best Performance

- IDNUM on the SWMMT definition statement. IDNUM provides unique identification of each network. IDNUM is used for sender or receiver verification on each link. If you code IDNUM, it must match the number of the sending station in the VTAM switched major node.

**Note:** Call verification security is not supported for SMMF.

- MAXOUT on the SWMMT definition statement. MAXOUT specifies the number of PIUs that can be sent before NCP requests a response.
- NETID on the SWMMT statement. NETID identifies the network that contains the adjacent link station. The NETID name on the SWMMT definition statement must match the NETID name on the NETWORK definition statement for that network.
- SWMMTID on the LINE definition statement. SWMMTID identifies the switched SMMF table. Code SWMMTID only for switched subarea links. The name you assign to SWMMTID must also appear on the first SWMMT definition statement.

**Note:** If you code SWMMTID, you must code MONLINK=CONTINUOUS or MONLINK=YES.

For a complete description of the process for remote loading and activation, refer to *NCP, SSP, and EP Generation and Loading Guide*.

---

## Coding ISDN Definitions for the Best Performance

There are several keywords that interact with each other to affect the performance of NCP ISDN resources. Because of the many interactions of these performance-related keywords, you need to tune these keywords for best performance in your environment. For most configurations, the defaults of these keywords may provide good performance. For some complex configurations, however, you need to tune some of these performance-related keywords. The following sections describe the keywords that are important to the performance of NCP ISDN resources.

### Performance-Related Keywords

The following keywords interact with each other to affect performance of your ISDN:

Keyword	Definition Statement	Default
CIR	LINE	NO
COMRATE	PU	(,1)
DATABLK	LINE	2048
DYNWIND	PU	(4,1,1)
LMI (TIMERS, ERRORT)	PU	CCITT ((10,15), (3,4))
MAXOUT	PU	8
RETRIES	LINE	(6,0,0)
TITIMER	LINE	
T1TIMER	LINE	(,6)
T2TIMER	LINE	

Try using the defaults of these keywords. If you need to improve performance in these simple configurations, try tuning the DYNWIND keyword. For complex configurations, you must tune all of these keywords to achieve optimal performance.

### Tuning Performance-Related Keywords

For FRTEs, the most important performance-related keywords are DYNWIND and T2TIMER. MAXOUT has a general effect on performance, but does not help in fine-tuning FRTEs.

The DATABLK and COMRATE keywords work together to define the relative priority among PVCs on a line. The amount of bandwidth for each PVC is controlled by these parameters. If you use the defaults of these keywords, the bandwidth is divided equally among all the PVCs on the line.

T1TIMER and RETRIES control frame recovery and line inoperative error condition timers and counts. Adjust these for timely error notifications in your environment. For simple configurations using T1 and E1 speeds, the default value of 6 seconds usually provides good performance and timely error detection. However, for slower speeds, the default may not work well.

TITIMER is an inactivity timer that causes a connection to become inoperative if the timer expires. If LMI is ANSI or CCITT and the remote device supports LMI network node interface (NNI), you can set TITIMER to its maximum value (1500).

---

## ISDN Accounting

Besides general session accounting, you can collect accounting information specific to ISDN. This ISDN data provides information about ISDN B-channel connections, for example, the duration of a call. For a description of the information provided to NPM in the ISDN Accounting Data Control Vector, see the Network Performance Monitor (NPM) Request Unit (RU) Formats chapter in *NCP and EP Reference Summary and Data Areas*, Volume 2.

Code the following definition statement and keywords to enable ISDN accounting:

BUILD	ISDNACC NPA SESSACC
-------	---------------------------

ISDNACC on the BUILD statement specifies whether the CSS is to collect ISDN accounting information. Code ISDNACC=YES to activate ISDN accounting.

NPA on the BUILD statement specifies whether NCP is to include the network performance analyzer in the system generation definition. Code NPA=YES to include the network performance analyzer and enable ISDN accounting.

SESSACC on the BUILD statement specifies whether NCP is to collect session accounting information. Code SESSACC=YES to activate session accounting and enable ISDN accounting.

Besides these keyword specifications, ISDN accounting requires that an ISDN physical line definition exist in the NCP generation definition. When ISDN accounting is enabled, NDF automatically adds the UACCNTG keyword on the GENEND statement with the appropriate entry point for ISDN.

## Sample ISDN Definition

Figure 7-12 shows NCP 1 and NCP 2 connected through an ISDN.

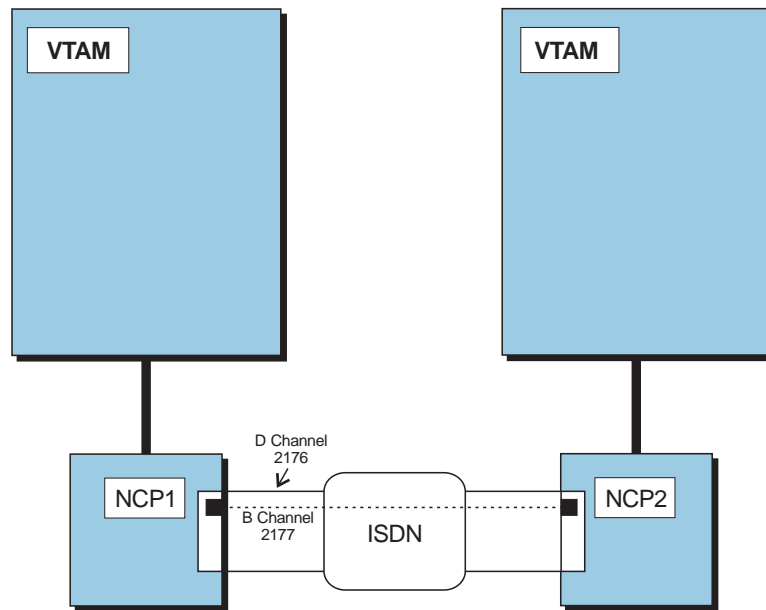

Figure 7-12. Connection through an ISDN

The ISDN connection consists of a physical connection and an ISDN B-channel connection. Figure 7-13 on page 7-36 shows how to define the ISDN connection shown in Figure 7-12.

## Sample ISDN Definition

```
*
*****
*           ISDN PHYSICAL DEFINITIONS           *
*****
PHYSG   GROUP DIAL=NO, ISDN=PHYSICAL
PHYSL   LINE  ADDRESS=2176, PORTADD=9, ISDNLPN=913039313933
PHYSPU  PU    PUTYPE=1
*
*****
*           ISDN B-CHANNEL DEFINITIONS          *
*****
CHANG   GROUP DIAL=YES, ISDN=(LOGICAL, B), PHYSRSC=PHYSPU
CHANL1  LINE  ADDRESS=2177, CALL=IN, ID=00123456
CHANPU1 PU    PUTYPE=1
*
CHANL2  LINE  ADDRESS=2178, CALL=IN, ID=00234567
CHANPU2 PU    PUTYPE=1
*
*****
*           ISDN LOGICAL DEFINITIONS (BNN)      *
*****
LOGIBG  GROUP DIAL=YES, ISDN=(LOGICAL, PER), PHYSRSC=NONE
LOGIBL1 LINE  ADDRESS=NONE
LOGIBP1 PU    PUTYPE=2
LOGIBL2 LINE  ADDRESS=NONE
LOGIBP2 PU    PUTYPE=2
*
*****
*           ISDN LOGICAL DEFINITIONS (INN)      *
*****
LOGIIG  GROUP DIAL=YES, ISDN=(LOGICAL, SUB), PHYSRSC=NONE, PUTYPE=4, *
        SDLCST=(PRIST, SECST)
LOGIIL  LINE  ADDRESS=NONE
LOGIIP  PU
*

```

Figure 7-13. Example: Defining ISDN Resources

---

## Chapter 8. Type 2.1 Node Support

Type 2.1 node support provides communication between logical units attached in a Systems Network Architecture (SNA) subarea network without requiring a host application program, such as VTAM, to establish sessions and relay information between the logical units. This node function enables you to complete the following processes:

- Attach type 2.1 physical units to NCP
- Use a type 2.1 physical unit to communicate through an SNA subarea network
- Improve connectivity of logical unit sessions by supporting independent logical units in the host domain and in the other domains in the network
- Establish multiple and parallel sessions through the SNA subarea network
- Perform adaptive session pacing.

NCP can also use the casual connection function to connect an adjacent NCP or VTAM as an SNA type 2.1 node. See “Defining Casual Connection Links between Subareas” on page 12-29 for information about using casual connection.

This chapter describes how to define type 2.1 node support and other support features available to type 2.1 nodes and composite type 2.1 nodes.

---

### Defining Type 2.1 Physical Units and Independent Logical Units

A type 2.1 physical unit and its associated independent logical units provide type 2.1 peripheral node support. A type 2.1 physical unit serves two purposes in a network:

- It can act as a peripheral node and communicate with any other node in the SNA network using an SSCP-PU session.
- It can communicate with another type 2.1 physical unit without an SSCP-LU session.

Figure 8-1 on page 8-2 shows an NCP linked to a nonswitched type 1 physical unit, a nonswitched type 2 physical unit, a switched type 2.1 physical unit with dependent logical units, and a nonswitched type 2.1 physical unit with dependent and independent logical units.

## Defining Type 2.1 Physical Units and Independent Logical Units

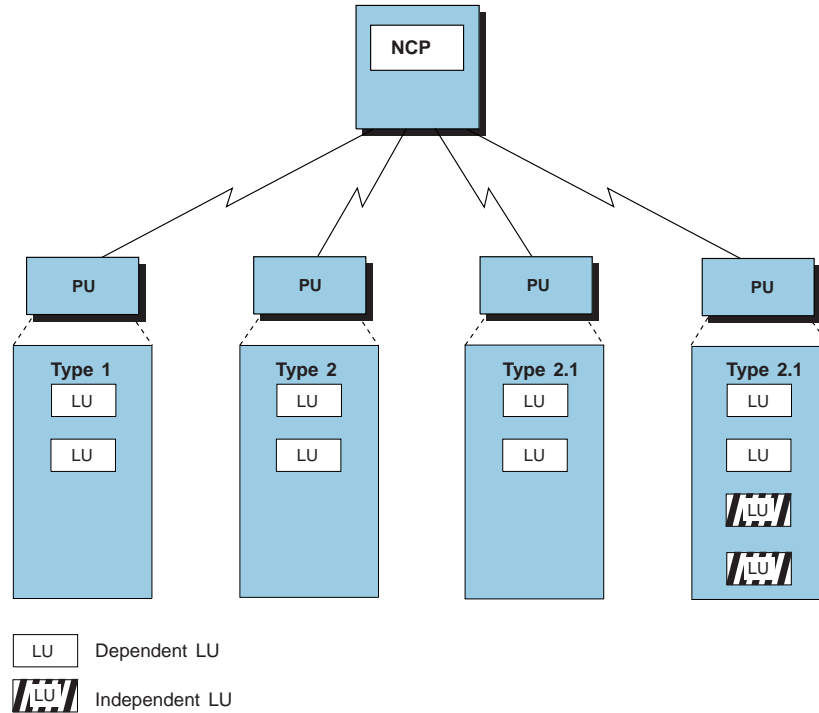

Figure 8-1. Type 2.1 Physical Unit Configuration

Independent logical units do not have to be defined in an NCP system generation definition because VTAM supports dynamic allocation of independent logical units. It is recommended that you define independent logical units as cross-domain resources in the VTAMLST. If your NCP generation definition contains the definition of independent logical units, you can delete the LU definition statements that define the independent logical units, define the LU definition statements as cross-domain resources in the VTAMLST, and increase the size of dynamic reconfiguration pools. As an alternative, you can code the GENILU keyword on the BUILD definition statement.

**Note:** The value of NAMTAB on the BUILD definition statement is affected by the definition of type 2.1 physical units. See page 2-7 for information on how to code the NAMTAB keyword.

Code the following definition statements and keywords to provide NCP with information about how to manage the physical and logical connections and how data is to be transmitted.

## Defining Type 2.1 Physical Units and Independent Logical Units

BUILD	ADPLIMIT
LUDRPOOL	NUMILU
GROUP	XMITDLY
LINE	TRANSFR
PU	MODULO NETID PUTYPE XID
LU	LOCADDR MAXSESS PACING RESSCB VPACING

### BUILD

ADPLIMIT on the BUILD definition statement limits the maximum window size that NCP permits on an adaptively paced session. For more information, see “Session Pacing” on page 8-4.

### LUDRPOOL

NUMILU on the LUDRPOOL definition statement determines how many independent logical units can be added through dynamic reconfiguration. When you increase the size of dynamic reconfiguration pools, you avoid session failures due to insufficient resources; however, when you define values that are too high, NCP can exceed the storage capacity of your communication controller.

### GROUP

XMITDLY on the GROUP definition statement specifies the number of seconds NCP is to delay initial transmission after establishing a connection with an incoming call. The delay gives the calling station time to transmit an XID to the type 2.1 node before the node solicits a response from the calling station.

### LINE

TRANSFR on the LINE definition statement defines the number of NCP buffers allocated to receive data in a single operation.

### PU

MODULO on the PU definition statement specifies how many information frames (I-frames) NCP is to send before it requests a response. If you choose to omit MODULO, type 2.1 physical units create a MODULO value in their format-3 XID exchange. If you choose to code MODULO, NCP selects either your MODULO definition or the XID-generated value, depending on which is smaller.

NETID on the PU definition statement creates a nonnative network attachment between NCP and a type 2.1 node in a different network by naming the adjacent network. VTAM monitors which network identifier the type 2.1 node can use when you code NETID and when LNCTL=SDLC, PUTYPE=2, and XID=YES, or when LNCTL=CA and PUTYPE=2.

## Defining Type 2.1 Physical Units and Independent Logical Units

PUTYPE identifies the physical unit type of a device. Code PUTYPE=2 when you define a type 2.1 physical unit.

XID specifies whether the physical unit can receive and respond to an XID while in normal disconnected mode (NDM). Code XID=YES when you define a type 2.1 physical unit.

### LU

LOCADDR on the LU definition statement specifies the address of the logical unit. Code LOCADDR=0 when you define an independent logical unit.

MAXSESS specifies the maximum number of LU-LU sessions in which an independent logical unit can participate on this link station. If you code MAXSESS on an LU definition statement, it overrides the MAXSESS value coded on the BUILD definition statement only for that independent logical unit. The value you code does not generate control blocks; it only limits the number of sessions in which that logical unit can participate on this link station. The limitation imposed by the MAXSESS value prevents an independent logical unit from monopolizing unreserved boundary session control blocks (BSBs). See page 8-9 for information about how to code MAXSESS on the BUILD definition statement.

RESSCB specifies how many session control blocks are to be generated and reserved for the defined independent logical unit. The number specified here will be added to the BSB pool and set aside for this logical unit. Each session with the independent logical unit requires one control block from the BSB pool. If the independent logical unit uses all the available session control blocks that you define, it can access additional session control blocks defined by the ADDSESS and AUXADDR keywords. Information about how to code ADDSESS and AUXADDR can be found on page 8-8.

**Note:** ADDSESS, AUXADDR, and RESSCB each create empty control blocks in control block pools, such as the BSB pool. Some of the control blocks are in the same pools, some are not. Detailed information about which control blocks get generated for ADDSESS, AUXADDR, and RESSCB can be found in the *NCP and EP Reference*.

PACING and VPACING on the LU statement help control session pacing as described in "Session Pacing."

### Session Pacing

When communication is established between two logical units, the data transfer rate is defined at the outset, using adaptive session pacing or fixed session pacing. Adaptive session pacing helps you to set an appropriate rate of response as conditions change dynamically between the logical units. NCP uses adaptive session pacing when both logical units support it; otherwise, NCP uses fixed session pacing. The pacing values required for fixed session pacing come from values defined in the BIND or from PACING on the LU definition statement.

Adaptive session pacing, which NCP uses by default when possible, can cause congestion within the network by allowing an application to send too much data before pausing for a pacing response from NCP. To avoid this condition, you can use the PACING and VPACING keywords to disable adaptive session pacing. You can also use the ADPLIMIT keyword to limit the maximum window size that NCP permits on an adaptively paced session.



## Defining Type 2.1 Physical Units and Independent Logical Units

Code the following definition statement and keywords to provide NCP with information about the type of session pacing and the specific values to be used.

BUILD	ADPLIMIT
LU	PACING VPACING

### BUILD

ADPLIMIT on the BUILD definition statement specifies the maximum window size that NCP sets in an adaptive pacing response message (IPM).

### LU

PACING on the LU definition statement defines the number of PIUs a logical unit is to send to NCP before transmission stops to await a pacing response from NCP. The pacing response indicates that NCP has received the data sent by the logical unit and that it is ready to accept more data.

For adaptive session pacing, the PACING value specifies an override of the batch mode of adaptive session pacing on the logical unit side of the session. PACING sets a fixed value for the receive window during batch processing. Use PACING to indicate the number of requests NCP can receive before it sends a pacing response.

VPACING specifies an override of the batch mode adaptive session pacing for the subarea side of the session. VPACING sets a fixed value for the receive window during batch processing. Use VPACING to indicate the number of requests NCP can receive before it sends a pacing response.

### Sample Definition for Type 2.1 Physical Units and Independent Logical Units

Figure 8-2 shows an NCP linked to a nonswitched type 2.1 physical unit with independent logical units.

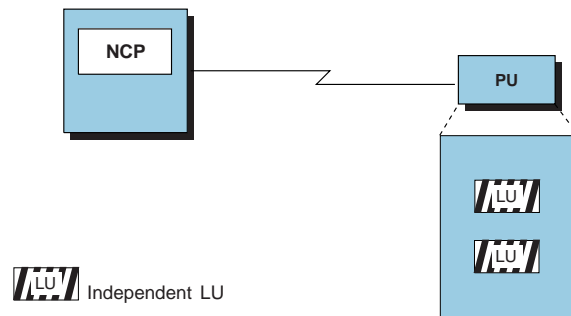

Figure 8-2. Type 2.1 Peripheral Node Configuration

Figure 8-3 on page 8-6 shows how to code the PU definition statements for the nonswitched type 2.1 physical unit shown in Figure 8-2. The LU definition statements for the independent logical units must follow the PU definition statement that defines the nonswitched type 2.1 physical unit. See “Sample Definition of Casual Connection” on page 12-33 for an example that shows you how to define type 2.1 connections to a nonnative network.

## Type 2.1 Support Functions

*	LUDRPOOL NUMILU=1500,	1500 independent LUs for dynamic reconfiguration
*	NUMTYP1=12,	12 dependent LUs for type 1 PUs in dynamic reconfiguration pool
*	NUMTYP2=12,	12 dependent LUs for type 2 or type 2.1 PUs in dynamic reconfiguration pool
*	.	
	.	
	.	
PU	ADDR=C1, IRETRY=YES, MAXDATA=521,	Nonswitched type 2.1 PU VTAM-only keyword
	.	
	.	
	.	
	PUTYPE=2, USSTAB=NOMSG10, XID=YES	VTAM-only keyword
	.	
	.	
	.	
LU	LOCADDR=0, RESSCB=10, PACING=7, ISTATUS=INACTIVE,	Independent logical unit for nonswitched type 2.1 PU VTAM-only keyword
	.	
	.	
	.	
LU	LOCADDR=0, RESSCB=100, PACING=7, ISTATUS=INACTIVE,	Independent logical unit for nonswitched type 2.1 PU
	.	
	.	
	.	

Figure 8-3. Example: Defining a Type 2.1 Physical Unit

## Type 2.1 Support Functions

When you define type 2.1 peripheral nodes, the following additional functions are supported by NCP:

- Independent logical units as cross-domain resources
- Multiple and parallel session support
- Peripheral primary logical units

You can define independent logical units to VTAM as cross-domain resources. When you do this, VTAM automatically creates independent logical units when they are needed and dynamically adds them to NCP. To implement this function, increase the size of dynamic reconfiguration pools for independent logical unit resources in order to avoid session failures due to insufficient resources. The sum of the values of the ADDSESS, AUXADDR, and NUMILU keywords is used to determine the total number of control blocks available in control block pools; therefore, the individual keyword values can be changed to increase or decrease the size of the pools. It is unwise to define an excessive amount of storage for the

dynamic reconfiguration pools, since it can cause NCP to exceed the storage capacity of your communication controller.

A type 2.1 peripheral node enables a logical unit to participate in multiple sessions with other logical units or establish parallel sessions with another logical unit. The logical unit associated with the type 2.1 node can be an application program or a peripheral logical unit. The number of multiple sessions is affected by the values coded on the ADDSESS and MAXSESS keywords.

Figure 8-4 illustrates multiple sessions between an independent logical unit and other logical units as well as parallel sessions between an independent logical unit and another logical unit.

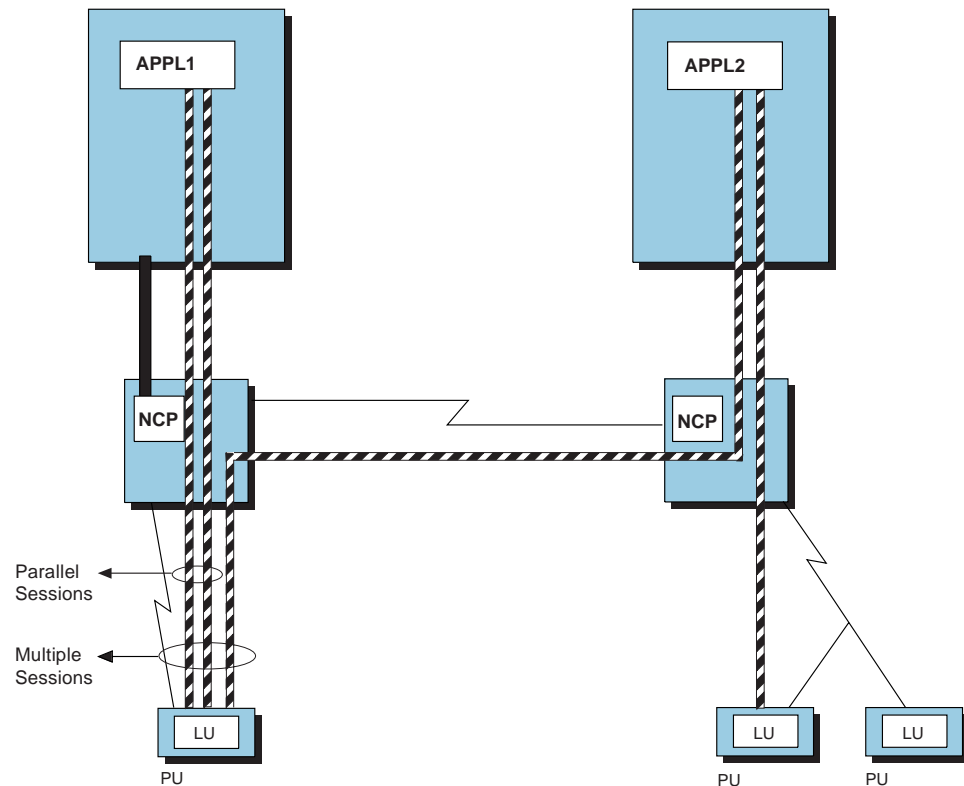

Figure 8-4. Multiple and Parallel Sessions between Logical Units

The NCP boundary function permits two logical units (one primary and one secondary) to communicate with each other without the presence of a host application program, such as VTAM. These logical units are known as peripheral logical units. The AUXADDR keyword provides for additional addresses to be assigned to the peripheral primary logical units.

Code the following definition statements and keywords to provide NCP with information about how to define the various session control blocks needed to make logical connections from a type 2.1 device to other logical units in the network.

## Type 2.1 Support Functions

BUILD	ADDSESS AUXADDR GENILU MAXSESS
LUDRPOOL	NUMILU

### BUILD

ADDSESS on the BUILD definition statement specifies the number of LU-LU boundary session control blocks (BSBs) available for use by any independent logical unit in addition to those reserved by RESSCB on the LU definition statement. The number of control blocks specified on ADDSESS will be added to the unreserved section of the BSB pool. One BSB is needed for every session in which the independent logical unit will be participating. If a particular logical unit needs to participate in more sessions than those reserved by the RESSCB keyword on the LU definition statement, additional session control blocks are obtained from the unreserved section of the BSB pool. See page 8-4 for information about the control blocks defined by the RESSCB keyword.

AUXADDR defines how many additional addresses are needed for all peripheral logical units. For each logical unit defined, one network address is automatically assigned. If any logical unit requires more than one primary logical unit (PLU) address for multiple sessions, code AUXADDR to indicate the total number of additional addresses required by all logical units (independent logical units can have multiple PLU addresses). An additional logical unit address control block is needed for each parallel session in which a given logical unit will participate as a PLU.

The control block total generated by ADDSESS coupled with a limit on the number of assigned addresses imposed by the AUXADDR value enables NCP to produce a pool of control blocks used when sessions are established. At resource definition time you might not know exactly how many control blocks you need until you examine all the factors that influence the number you should define. Before you estimate a total, consider the following guidelines:

- Do not limit your control block total to exactly the number of independent logical units and parallel sessions in the network, or you might not have enough control blocks to begin a session. Some sessions, such as one established by the SNA session service manager, exist briefly when type 2.1 physical unit nodes initiate connections. If the control block pool cannot provide extra control blocks required by these transitory sessions, your independent logical unit sessions might not work.
- Defining excessive values for ADDSESS and AUXADDR can cause NCP to exceed the storage capacity of your communication controller. It is best to determine a value that includes a control block for each independent logical unit that can be involved in parallel sessions plus several control blocks for transitory sessions that are established and broken during the connection process for type 2.1 physical units.

**Notes:**

1. You can cause NCP to dynamically create additional control blocks for LU-LU boundary sessions when needed. See “Dynamically Created Control Blocks” on page 2-10 for more information.
2. ADDSESS, AUXADDR, RESSCB, and NUMILU each create empty control blocks in control block pools, such as the BSB pool. Some of the control blocks are in the same pools, some are not. For detailed information about which control blocks get created for ADDSESS, AUXADDR, RESSCB, and NUMILU, see the chapter on control block management in the *NCP and EP Reference*.

GENILU specifies whether independent logical unit definitions are to be processed or ignored during the system generation. Code GENILU=NO to prevent NDF from generating resource control blocks and element addresses for NCP if you prefer them to be defined as dynamic VTAM cross-domain resources. NDF automatically increases dynamic reconfiguration pool sizes for each independent logical unit defined so that the independent logical unit can be created and added to NCP when needed. VTAM V4R1 and later releases provide dynamic definition of independent logical units.

MAXSESS specifies the maximum number of LU-LU sessions that a boundary logical unit can have per link station in this NCP. The value you code limits the number of sessions in which a single logical unit can participate. The limitation imposed by the MAXSESS value prevents a logical unit from monopolizing unreserved session control blocks. If an independent logical unit is able to establish sessions over more than one link station, the independent logical unit can have the number of sessions specified with MAXSESS=*sessions* on each of those link stations.

Determine a value for MAXSESS by considering the size of your BSB pool, the number of independent logical units, the number of potential logical unit sessions, and the number of transitory sessions established and broken as type 2.1 physical units communicate.

When you code MAXSESS on the BUILD definition statement, all independent logical units associated with NCP are limited to the same number of session control blocks. You can restrict an independent logical unit to different session limits on different link stations by coding MAXSESS on the LU definition statement for the logical unit under the PU statements for the different link stations. See page 8-4 for information about how to code MAXSESS on the LU definition statement.

**LUDRPOOL**

NUMILU on the LUDRPOOL definition statement specifies how many independent logical units can be added through dynamic reconfiguration.

**Sample Definitions for Type 2.1 Support Functions**

Figure 8-5 on page 8-10 shows how to define the parallel and multiple sessions shown in Figure 8-4 on page 8-7. Figure 8-5 also provides for dynamic reconfiguration.

## Type 2.1 Support Functions

BUILD	ADDSESS=200,	200 LU-LU session control blocks
	AUXADDR=1000,	1000 PLU addresses to be assigned
	BACKUP=300,	300 LUs with XRF support
	BFRS=104,	Buffer size
	.	
	.	
	.	
	MAXSESS=2500,	2500 maximum LU-LU sessions
	MAXSSCP=8,	8 concurrent SSCP sessions
	MODEL=3745,	
	NAMTAB=3000,	3000 entries in network names table
	.	
	.	
	.	

Figure 8-5. Example: Defining Parallel and Multiple Sessions

## Independent Logical Unit Resource Pools

Figure 8-6 on page 8-11 shows a configuration with independent logical units in session with other logical units and the NCP logical unit control block pool that supports the independent LU-LU sessions. You can create the control block pool when you define the ADDSESS, AUXADDR, and NUMILU keywords. The sum of the values of ADDSESS, AUXADDR, and NUMILU is used to determine the total number of control blocks available.

**Note:** The ADDSESS, AUXADDR, and NUMILU keywords each create a empty control blocks in control block pools. Some of the control blocks are in the same pools, some are not. For details on which control blocks each keyword creates, see the control block management information in the *NCP and EP Reference*.

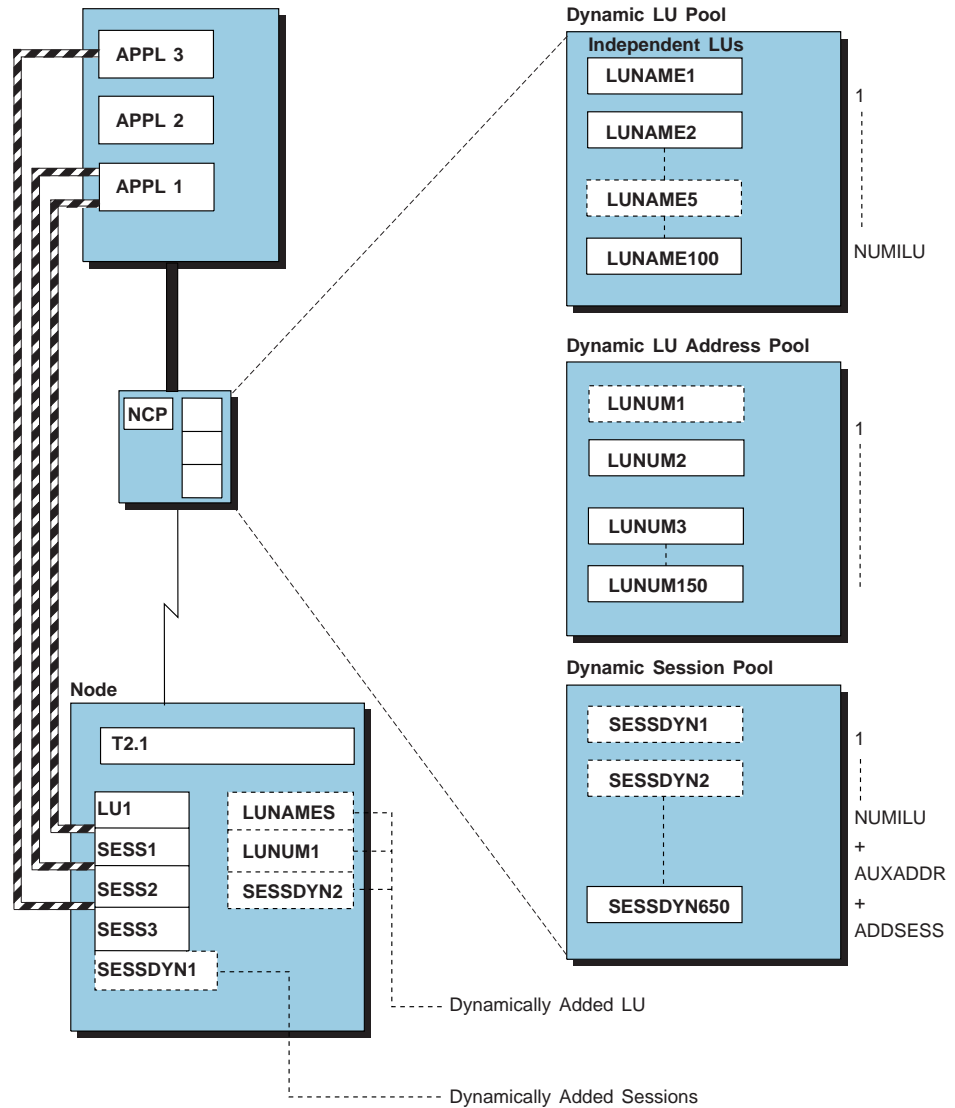

Figure 8-6. Independent Logical Unit Control Block Pools

## Independent LUs in a Nonnative Network

To establish sessions with independent logical units in a nonnative network, you can define the logical units explicitly, although it is not required. If the physical unit associated with the independent logical units is in a separate network, the logical units can be dynamically added when a session with them is initiated.

The configuration of an adjacent APPN network is not apparent to NCP. NCP has definitions only of directly attached nodes. If a session with NCP is established from a node in a nonnative network, NCP cannot predict the path that will be used. Although you define a logical unit to be associated with a particular physical unit, the logical unit can establish a session through a different physical unit. When this happens, the control blocks associated with the logical unit are unused.

Figure 8-7 on page 8-14 shows an LU-LU session between LU1 and LU2 over a path through network node 3 (NN3) and NCP1. When LU1 is associated with the physical unit NN2 in the system generation definition, resource control blocks are generated for LU1. Because the path is through a different physical unit (NN3),

## Type 2.1 Support Functions

NCP1 cannot use the existing resource control blocks; instead, it uses control blocks that are dynamically created.

You can define logical units in nonnative networks or let them be defined dynamically. To define nonnative network logical units:

- Define the physical unit in the adjacent nonnative network with a PU definition statement.
- Identify the network name of each logical unit that is not in the nonnative network by coding NETID on the LU definition statement.
- Increase the NAMTAB value on the BUILD definition statement so that the network names table is large enough to add the name of each network.

Code the following definition statements and keywords to provide NCP with information about how to manage the relationship with the logical unit in the nonnative network.

BUILD	NAMTAB
PU	NETID
LU	LUDR NETID

### BUILD

NAMTAB on the BUILD definition statement defines the number of entries in the network names table. To support connections with logical units in nonnative networks, increment the existing number of network names as follows:

- One entry for each network, not defined in this NCP, which has logical units within the boundary of this NCP in sessions passing through this NCP
- One entry for each independent logical unit, within the boundary of this NCP, which has a unique control point name and will have sessions passing through this NCP
- One entry for each independent logical unit, not within the boundary of this NCP, which has a unique control point name and will have sessions with logical units in the boundary of this NCP.

See page 2-7 for complete information about the minimum number of entries that should be defined for this keyword.

**Note:** You can cause NCP to dynamically create additional network names table entries when needed. See “Dynamically Created Control Blocks” on page 2-10 for more information.

### PU

NETID on the PU definition statement creates a nonnative network attachment between NCP and a type 2.1 node in a different network by naming the adjacent network. VTAM monitors which network identifier the type 2.1 node can use when you code NETID and when LNCTL=SDLC, PUTYPE=2, and XID=YES, or when LNCTL=CA and PUTYPE=2.



### LU

LUDR on the LU definition statement specifies whether the logical unit can be deleted using the dynamic reconfiguration function.

NETID on the LU definition statement specifies the name of the network where the independent logical unit resides. This is useful only when the logical unit and the physical unit are in different networks.

---

## NCP and VTAM As a Composite Type 2.1 Node

NCP and VTAM work together to appear as a type 2.1 node to other attached type 2.1 nodes. VTAM and NCP are individual subareas in a subarea network. But attached type 2.1 nodes treat the VTAM and NCP subarea network as a single type 2.1 node, called a composite type 2.1 node.

The level of function supported in the composite type 2.1 node depends on the level of VTAM that owns the NCP (V7R3 or a later release).

- Before VTAM V4R1:  
A composite type 2.1 node functions as a low-entry networking (LEN) node.
- VTAM V4R1:  
Composite type 2.1 node function supports Advanced Peer-to-Peer Networking (APPN). The composite type 2.1 node is called a composite Automatic Network Routing (ANR) node. It functions as an APPN network node for type 2.1 nodes that are attached to it.
- VTAM V4R3 or later:  
Composite type 2.1 node function supports APPN high performance routing (HPR). The composite type 2.1 node is called a composite ANR node. It functions as an APPN HPR ANR node for type 2.1 nodes attached to it in an APPN HPR network. (It functions as an APPN network node for type 2.1 nodes attached to it in an APPN network that does not support HPR.)

Figure 8-7 on page 8-14 shows a host processor and three NCPs that appear as a composite network node or as a composite ANR node. NN1, NN2, NN3, and NN4 are APPN network nodes. NN1 and NN4 support RTP function and can act as RTP endpoint nodes in an APPN HPR environment. NN2 and NN3 support ANR function and can act as ANR nodes in an APPN HPR environment. NCP1 and NCP3 in the composite node's subarea network attach to adjacent type 2.1 APPN or APPN HPR nodes in the APPN or APPN HPR network. NCP2 does not need to support APPN or APPN HPR for the composite node to perform as a network node or as an ANR node.

The APPN HPR definitions described in the following sections are applicable to the nodes in the composite ANR node's subarea network that attach to adjacent type 2.1 APPN HPR nodes.

## NCP and VTAM as a Composite Type 2.1 Node

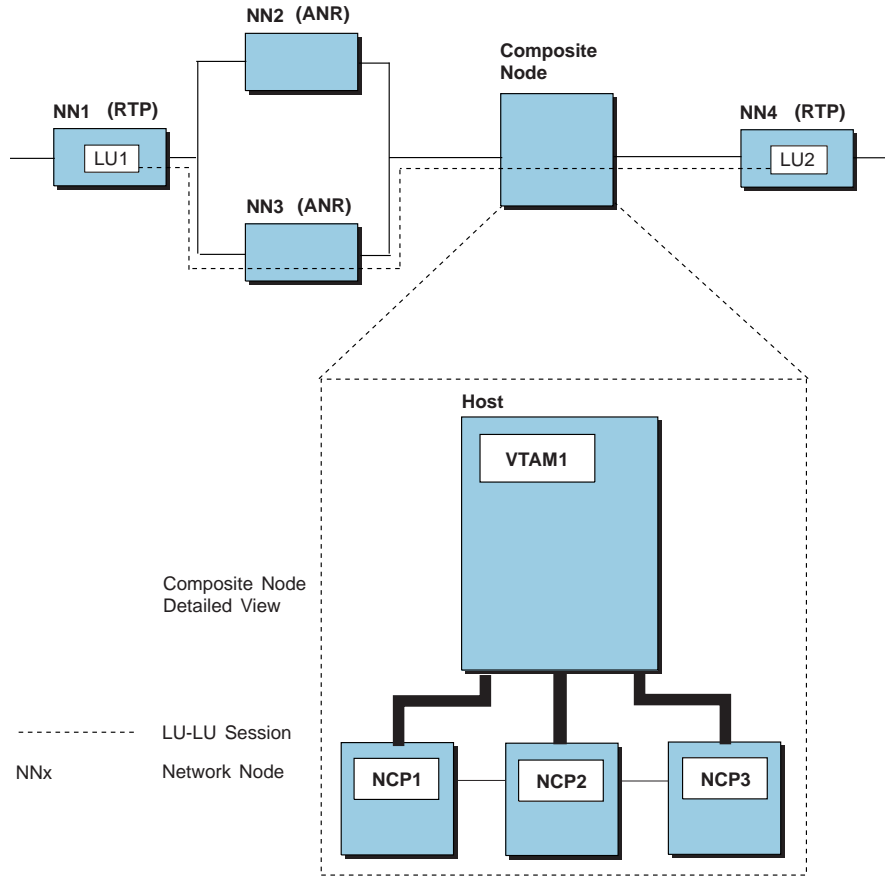

Figure 8-7. The NCP Role in an APPN Network

## Generating APPN and LEN Support

To generate a composite type 2.1 node as a LEN node or as an APPN network node, see the *VTAM Network Implementation Guide* and the *VTAM Resource Definition Reference*.

## Generating APPN HPR Support in NCP

APPN HPR is an enhancement to APPN that improves session performance by minimizing the processing required in intermediate APPN nodes along the session path. Functions performed in intermediate nodes in a non-HPR APPN network are done at the edges of an APPN HPR network.

In an APPN HPR network, there are rapid transport protocol (RTP) nodes and automatic network routing (ANR) nodes. RTP nodes are at the edges of the APPN HPR network. ANR nodes are the intermediate nodes.

### RTP Nodes

RTP nodes set up the high performance route, that is called the RTP connection, across the HPR-capable portion of the APPN network. The RTP nodes map LU-LU sessions to an RTP connection. Session data flows on the RTP connection. If the RTP connection fails because of an intermediate node or link failure, the RTP node sets up an alternate RTP connection. Without disrupting the flow of session data, the RTP node switches sessions over to the alternate RTP connection.

During the setup of the RTP route, the RTP endpoints gather statistics about the intermediate nodes and links over which the RTP route will flow. The flow control mechanism in each RTP endpoint uses these statistics to determine the rate at which to send data on the RTP route.

The RTP nodes also perform the following functions, that are done by the intermediate nodes in a non-HPR APPN network:

- End-to-end error recovery for each PIU (see “Defining the Characteristics of HPR-Capable Links” on page 8-20 for more information)
- Segmentation and reassembly of large PIUs
- Flow control for the entire HPR portion of the session path.

### ANR Nodes

ANR nodes participate in RTP route setup. After the RTP route is established, ANR nodes support low-level routing of data that flows on the RTP route. Because ANR nodes do not perform APPN intermediate session routing functions, ANR nodes are not aware of individual sessions. Storage is saved because the ANR nodes do not need session control blocks. Also, ANR nodes do not have to perform link-level error recovery for data that flows along an RTP route. Therefore, processing in the ANR nodes is reduced.

A composite ANR node, besides performing ANR node function, also does special processing across the subarea network for:

- RTP route setup
- Low-level routing of data on the RTP connection.

### Keywords for APPN Support

The following sections describe the keywords that provide APPN HPR support in NCP. None of these keywords is required. APPN HPR definitions are required only in the NCPs of the subarea network that are attached to the adjacent type 2.1 APPN HPR nodes. The APPN HPR definitions are not required for the intermediate subarea nodes.

### Defining the Characteristics of the Composite ANR Node

The NCP in a composite ANR node, provides values that represent the characteristics of the subarea network portion of the composite ANR node. You define these values using the BUILD statement. The characteristics about the composite ANR node that NCP can provide values for are:

- The maximum packet size
- The accumulated transmission time
- The minimum link capacity.

You can also indicate whether you want NCP to provide snap trace information about HPR resources by specifying the HPRSNAP keyword.

Code the following keywords to define these characteristics for the composite ANR node.

## NCP and VTAM as a Composite Type 2.1 Node

BUILD	HPR
	HPRMPS
	HPRATT
	HPRMLC
	HPRSNAP
PU	HPRQLIM

### BUILD

HPR on the BUILD definition statement enables NCP to be a part of a composite node.

HPRMPS on the BUILD definition statement defines the largest packet that can be sent across the composite ANR node's subarea network without being segmented on any of the subarea links along the path.

**When all NCPs in the subarea network are V7R3 or later:** Code 0 for the value of HPRMPS, or let it default to 0. The correct HPRMPS value will be calculated.

**When intermediate NCPs in the subarea network are V7R2 or earlier:** Carefully code an HPRMPS value for the subarea network on one of the V7R3 or later NCPs in the subarea network.

When you code the MAXDATA keyword for all the subarea links in the composite ANR node subarea network, use the smallest MAXDATA value of all these links as the value for the HPRMPS keyword.

If you have not coded the MAXDATA keyword for all of the subarea links, you must figure out the smallest segment size that can be used in the subarea network. Table 8-1 on page 8-17 shows the segment sizes used for each line protocol. Compare the values for all the subarea links, including those with MAXDATA coded and those without. Use the smallest segment size as the value for the HPRMPS keyword.

**Note:** An HPRMPS value for the V7R3 or later NCPs is calculated but does not include NCPs that are V7R2 or earlier. The value you code on the HPRMPS keyword is compared to the value calculated for the V7R3 or later NCPs, and the smaller of the two values is used. When the HPRMPS value is too large, the RTP nodes might build data packets that must be segmented and reassembled as they flow across the subarea network, thus increasing processing in the composite ANR node.

Table 8-1. Segment Sizes used by NCP

Line Protocol	Keywords that Affect Segment Size	How to Calculate Segment Size
SDLC	TRANSFR, BFRS	$(\text{TRANSFR} * \text{BFRS}) - 18$ bytes <b>1</b>
Token Ring	MAXTSL	MAXTSL value <b>2</b>
NTRI	RCVBUFC	$\text{RCVBUFC value} - 36$ bytes <b>3</b>
Frame relay (BAN)	MAXFRAME	MAXFRAME value-32 bytes or LF-4 or MAXTSL-36 <b>4</b>
Frame relay	MAXFRAME	MAXFRAME value-16 bytes <b>4</b>
ISDN (BAN)	MAXFRAME	MAXFRAME value-32 bytes or LF-4 or MAXTSL-36 <b>5</b>
ISDN	MAXFRAME	MAXFRAME value-16 bytes <b>5</b>

**1** The PIU segment size for an SDLC link depends on the TRANSFR value and the BFRS value of the adjacent NCP, which are transferred when the XID exchange takes place. Multiply the TRANSFR value of the adjacent NCP by the BFRS value and subtract 18 bytes from the result.

**2** The PIU segment size for a 3746 Model 900 Token Ring or NTRI depends on the MAXTSL value.

**3** When you define a NTRI link, you can code RCVBUFC to limit the maximum segment size to be received. NCP uses the smaller of the MAXTSL value of this node or the RCVBUFC-36 value of the adjacent node as the segment size of the NTRI link.

**4** For a frame-relay boundary access node (BAN) format, the PIU segment size for a frame-relay link is the smaller of (1) this link's MAXFRAME-32 or LF-4, whichever is smaller, or (2) the adjacent node's LF-4 or MAXTSL-36, if the adjacent connection is to an NCP, whichever is smaller. LF is the largest frame indicator field in the routing information field in a frame-relay BAN frame. For all other connections, the PIU segment size for a frame-relay link is the smaller of (1) this link's MAXFRAME-16 or (2) the adjacent node's MAXFRAME-16.

**5** For a frame-relay boundary access node (BAN) format, the PIU segment size for an ISDN link is the smaller of (1) this link's MAXFRAME-32 or LF-4, whichever is smaller, or (2) the adjacent node's LF-4 or MAXTSL-36, if the adjacent connection is to an NCP, whichever is smaller. LF is the largest frame indicator field in the routing information field in a frame-relay BAN frame. For all other connections, the PIU segment size for an ISDN link is the smaller of (1) this link's MAXFRAME-16 or (2) the adjacent node's MAXFRAME-16.

See "MLTG Segment Size" on page 12-23 for more information about PIU segment sizes.

HPRATT is used to define the average time in microseconds that it takes to route 1200 bits across the composite ANR node's subarea network. NCP estimates this time for the subarea network if the value is greater than or equal to 200 000 microseconds. If the value is less than 200 000 microseconds, code a value on the HPRATT keyword. The value you provide is used when transmission begins. After transmission has begun, the actual value, which the RTP endpoints track, is used.

## NCP and VTAM as a Composite Type 2.1 Node

To estimate the value to use, if needed, determine the time it takes to send 1200 bits across a typical path in the subarea network. Table 8-2 on page 8-18 shows the time it takes to send 1200 bits across the different subarea line types for times less than 200 000 microseconds. If the typical path through the subarea network requires more than one subarea node, use the sum of all the links along the path.

*Table 8-2. Accumulated Transmission Time By Line Type and Speed*

Line Type	Line Speed (bits per second)	Accumulated Transmission Time (microseconds)
Token Ring	—	776 (TIC1)
	—	362 (TIC2)
	—	90 (TIC3)
ESCON Channel	—	90
Type 6 Channel	—	390
Type 7 Channel	—	203
SDLC or Frame Relay	9600	125000
	19200	62500
	38400	31250
	55855	21485
	64000	18750
	245760	4883
	256000	4688
	512000	2344
	1024000	1172
	1474560	814
	1536000	782
	1843200	652
2048000	586	
ISDN	64000	18750

HPRMLC specifies the capacity in kilobits per second of the slowest subarea transmission group in the composite ANR node's subarea network that can carry APPN HPR data. Use Table 8-3 on page 8-19 to help you determine the value to use. If a transmission group is a MLTG, use the sum of the capacities of all its links.

The default is 9 kilobits per second.

## NCP and VTAM as a Composite Type 2.1 Node

<i>Table 8-3. Minimum Link Capacity by Line Type and Speed</i>		
Line Type	Line Speed (bits per second)	Minimum Link Capacity (kilobits per second)
Token Ring	—	1510 (TIC1) 3238 (TIC2) 13062 (TIC3)
ESCON Channel	—	13062
Type 6 Channel	—	3008
Type 7 Channel	—	5760
SDLC or Frame Relay	75	1
	100	1
	110	1
	134	1
	200	1
	300	1
	600	1
	1200	1
	2400	2
	4800	4
	9600	9
	19200	18
	38400	37
	55855	54
	64000	62
	245760	240
	256000	250
	512000	500
	1024000	1000
1474560	1440	
1536000	1500	
1843200	1800	
2048000	2000	
ISDN	64000	62

HPRSNAP specifies whether you want the NCP snap trace enabled for APPN HPR resources. You can trace one or both of the following:

- Route setup requests that NCP receives and routes for route setup processing.
- Network layer packets (NLPs), which are the basic transmission units for APPN HPR, that NCP receives and routes for ANR.

## NCP and VTAM as a Composite Type 2.1 Node

**Note:** The snap trace can degrade NCP performance and should be used only when requested by an IBM support representative.

### PU

HPRQLIM lets you control the amount of APPN HPR data queued for transmission on link stations in the composite ANR node's subarea network. If an APPN HPR frame arriving at a link station would cause the transmission queue to exceed its limit, the frame is discarded. If the limit is coded as 0, which is the default, there is no limit to the amount of APPN HPR data that can be added to the transmission queue. Note that flow control mechanisms such as session pacing or VR pacing, which work for other SNA data, do not affect APPN HPR data. The flow control mechanisms used by the RTP endpoints detect queueing delays and slow the transmission rate to prevent transmission queues from getting too large.

**Note:** A small HPRQLIM defined for a boundary channel-link may eliminate the effectiveness of the channel attention delay. NCP will defeat the blocking delay if the HPR queue limit is exceeded.

### Defining the Characteristics of HPR-Capable Links

You do not need to define a maximum packet size, accumulated transmission time, or a minimum link capacity for links to an adjacent HPR-capable node. NCP determines values for these based on parameters that are already coded on link station definitions (such as TRANSFR or SPEED) and based on values that are negotiated with the adjacent node during link station activation. However, there are keywords that allow you to tune link station operation in an APPN HPR environment.

Code the following keywords to tune link station operation in a composite ANR node.

BUILD	HPRQLIM
LINE	SPEED
PU	LLERP HPRQLIM

### BUILD

HPRQLIM lets you control the amount of APPN HPR data queued for transmission on link stations in the composite ANR node's subarea network. If an APPN HPR frame arriving at a link station would cause the transmission queue to exceed its limit, the frame is discarded. If the limit is coded as 0, which is the default, there is no limit to the amount of APPN HPR data that can be added to the transmission queue. Note that flow control mechanisms such as session pacing or VR pacing, which work for other SNA data, do not affect APPN HPR data. The flow control mechanisms used by the RTP endpoints detect queueing delays and slow the transmission rate to prevent transmission queues from getting too large.

### LINE

SPEED specifies the line speed, which NCP uses to calculate the link capacity and transmission time that it reports to the RTP node for SDLC peripheral lines and frame-relay physical peripheral lines. The flow control mechanism of the RTP node uses this information. Code the SPEED keyword for SDLC peripheral lines and frame-relay physical peripheral lines that support APPN HPR data to ensure that the APPN HPR flow control mechanism works correctly.



### PU

Starting with VTAM V4R4 and NCP V7R6, the CAPACITY value from VTAM's topology database is used to determine link capacity and transmission time instead of the SPEED keyword. The value coded on the SPEED keyword is still used for earlier versions of VTAM and NCP.

LLERP specifies whether the link station will perform link-level error recovery procedures (ERPs) when sending HPR data on this link station. Specify LLERP=NOTPREF if you want NCP to bypass the error recovery procedures; it is best to bypass link-level ERP when transmitting HPR data over highly reliable lines. Specify LLERP=REQUIRED only if the line quality is poor and the adjacent node supports the use of link-level ERP for HPR data.

NCP supports the use of link-level ERP for HPR data on all link stations which support HPR. NCP supports sending HPR data without using link-level error recovery only on the following link station types:

- Frame-relay logical subarea
- Frame-relay logical peripheral
- NTRI logical peripheral
- 3746 Model 900 Token-Ring logical peripheral
- 3746 Model 900 Token-Ring logical subarea
- ISDN logical subarea
- ISDN logical peripheral

Link level ERP support for HPR data is defined on the physical port definition: on the frame-relay LMI PU, ISDN physical PU, or on the Token-Ring physical PU for SNA (the one with NETWORK=SNA). The logical connections that map to the physical port will inherit that physical's defined (or defaulted) support for LLERP. If LLERP=NOTPREF was coded on the physical port, you may override that by coding LLERP=REQUIRED on the logical definitions as follows:

**Frame-Relay Logical Subarea:** Code LLERP=REQUIRED on the logical subarea PU statement in the NCP definition deck.

**3746 Model 900 Token-Ring Logical Subarea:** Code LLERP=REQUIRED on the logical subarea PU statement in the NCP definition deck (starting with NCP V7R4).

See the *VTAM Network Implementation Guide* for information about VTAM in an APPN or APPN HPR environment.

For X.25 ODLC stations, you do not code LLERP because ERP is always required. For information about HPR support for X.25 ODLC stations, see *NCP Version 7 and X.25 NPSI Version 3 Planning and Installation*.

### Session Control Block Requirements in a Composite ANR Node

As you move LU-LU sessions to the APPN HPR network, you may find that you can lower the values you generate for the following keywords, which define session control block requirements:

- ADDSESS (BUILD)
- AUXADDR (BUILD)
- NAMTAB (BUILD)
- NUMILU (LUDRPOOL)
- SESSACC (the *nscnum* and *nscx* parameters) (BUILD).

## NCP and VTAM as a Composite Type 2.1 Node

**Note:** You can monitor your session control block usage with NTuneMON.

---

## Chapter 9. Block Handlers

You can write block handlers and block handler sets to add certain data handling functions to NCP for BSC or start-stop devices. These functions typically examine and manipulate incoming or outgoing data contained in NCP buffers. If you understand NCP and your access method, adding such routines to NCP is unlikely to disrupt the NCP code. However, adding more complex functions, such as leasing and releasing buffers or scheduling I/O operations, requires a thorough understanding of the internal operation of NCP and the access method. Approach the adding of such routines with care to avoid disrupting NCP logic. See *NCP and SSP Customization Guide* for information about how to write a block handler.

This chapter describes how to define the block handler to NCP, and how to use a block handler and a block handler set.

---

### Defining a Block Handler

A block handler performs special functions for blocks of message data received by NCP. These functions can be performed on data received by NCP either from the access method before it sends it to the BSC or start-stop device, or from the device before it sends the data to the access method. The requirements for determining how NCP processes message data depend on the application and can vary for different devices and different components of devices.

Block handlers run at the following points:

- Point 1 Processes output data immediately upon receipt from the access method before NCP determines that a link is available for communication with the output device.
- Point 2 Processes output data just before sending data on the link after NCP determines that a link is available for communication with the output device.  
Processes input data just after receiving data from the link and while the link is still being held for the input device.
- Point 3 Processes input data received from an input device after NCP releases the link to which the device is attached so that the link can be used to communicate with another device.

Code the following definition statements and keywords to provide NCP with control information for the block handler and the execution point of the block handler routines.

## Defining a Block Handler

STARTBH	BHEXEC
EDIT	BKSP
DATETIME	DATE DATEFMT INSERT PT2EXEC TIME
UBHR	ACCESS COMMAND ENTRY NAME PT2EXEC
REMOVCTL	
ENDBH	

### STARTBH

BHEXEC on the STARTBH definition statement names the point at which the block handling routine executes. The STARTBH definition statement identifies the beginning of a block handling routine definition; The ENDBH definition statement ends the definition of a block handling routine.

### EDIT

BKSP on the EDIT definition statement designates a character to be used as a text-canceling character by the keyboard operator. The operator uses the text-canceling character to mark text characters for deletion. NCP corrects the entered text by scanning each block of data received for any text-canceling characters and deleting each text-canceling character it finds, plus the text character preceding each canceling character.

For example, a keyboard operator types COMMUNCIATE and, seeing that it is misspelled, enters 5 text-canceling characters to return to the first incorrect character. The keyboard operator continues by entering the correct characters. If BKSP identifies the backspace character as the text-canceling character, the keyboard operator enters:

```
COMMUNCIATE bks bks bks bks bks ICATE
```

NCP deletes the 5 text-canceling characters (backspaces) plus the 5 text characters before those backspaces. The remaining characters form the correctly spelled word, COMMUNICATE. The text-canceling character does not have to be a backspace character. Use any other character (except a line-control character) that is not used in any other way within message text. Code the EDIT definition statement if the block handling routine processes input data at point 2 or point 3.

## DATETIME

DATE on the DATETIME definition statement gives NCP the current date to insert into the block handler. When you code DATE=YES, NCP places the date immediately before the first text character in the block.

DATEFMT specifies the format of the date inserted into the block. Select one of the following four formats:

- Month/day/year (10/21/93)
- Year/month/day (93/10/21)
- Day/month/year (21/10/93)
- Julian date (93.294).

INSERT specifies whether NCP is to insert the date and time only in the first block of each message or in all blocks.

PT2EXEC informs NCP that the block handling routine is executable only at point 2 and indicates whether the date and time are to be inserted before or after the I/O operation.

TIME gives NCP the current time to insert into the block handler. When you code TIME=YES, NCP places the continental time immediately before the first text character in the block. If you code both DATE and TIME, the time follows the date.

**Note:** DATE and TIME both have a default of YES; however, you cannot code both DATE=NO and TIME=NO. Either DATE or TIME must be included in the block.

## UBHR

ACCESS on the UBHR definition statement specifies whether the user-written block handling routine processes only error-free blocks of data or only blocks containing errors. Code ACCESS only if the block handling routine is executable at point 2 or point 3.

COMMAND indicates whether the user-written block handling routine processes input data received in response to a read request, an invite request, or both. Code COMMAND only if the block handling routine is executable at point 2 or point 3 and processes error-free, incoming data.

ENTRY specifies the entry point within the user-written module identified on the NAME keyword.

NAME identifies the name of the user-written module. The name of the user-written module is included in the JCL or EXEC for the linkage editor step in the NCP generation procedure.

PT2EXEC specifies whether the user-written block handling routine processes outgoing message data before the I/O operation, or input message data after the I/O operation. Use PT2EXEC if the block handling routine is executable only at point 2.

## Defining a Block Handler

### REMOVCTL

The REMOVCTL definition statement causes NCP to remove the ending control characters from incoming data blocks for TWX terminals. NCP removes these control characters only from data blocks in which it detects an ending sequence. This definition statement has no keywords. Code the REMOVCTL definition statement if start-stop devices are to be defined.

### ENDBH

The ENDBH definition statement ends the definition of a block handling routine.

## Defining a Block Handler Set

A block handler set is a collection of block handlers that process message data received at point 1, point 2, or point 3. Code the following definition statement and keywords to provide NCP with information about running the block handler set and the execution points for individual block handlers.

BHSET	EXEC
	PT1
	PT2
	PT3

EXEC on the BHSET definition statement specifies whether the block handler set can run by command from the access method when it is dynamically assigned to a BSC or start-stop device.

PT1, PT2, and PT3 identify the names of the block handlers running at points 1, 2, and 3, respectively.

### Sample Definition of a Block Handler and a Block Handler Set

Figure 9-1 on page 9-5 shows sample coding to produce a block handler and a block handler set.

```

GENEND ORDHI=(XXXSSBH,...)
.
.
*
SSBH1  STARTBH BHEXEC=PT1
*
        UBHR  NAME=XXXSSBH,
        ENTRY=XXXSSBH1
*
        ENDBH
*
SSBH2  STARTBH BHEXEC=PT2
*
        EDIT  BKSP=16
*
        DATETIME TIME=YES,
        DATE=NO,
        INSERT=FIRST,
        PT2EXEC=BEFORE
*
        UBHR  NAME=XXXSSBH,
        ENTRY=XXXSSBH2,
        ACCESS=GOOD,
        COMMAND=BOTH
*
        ENDBH
*

```

Figure 9-1 (Part 1 of 2). Example: Defining a Block Handler and Block Handler Set

```

SSBH3  STARTBH BHEXEC=PT3
*
        UBHR  NAME=XXXSSBH,
        ENTRY=XXXSSBH3
*
        ENDBH
*
SSBH3A STARTBH BHEXEC=PT3
*
        UBHR  NAME=ZZZSSBH,
        ENTRY=ZZZSSBH3
*
        ENDBH
*
SSBHSET1 BHSET EXEC=YES,
        PT1=SSBH1,
        PT2=SSBH2,
        PT3=SSBH3
*
SSBHSET2 BHSET EXEC=YES,
        PT1=SSBH1,
        PT2=SSBH2,
        PT3=SSBH3Z
*
        .
        .
        .
*
GENEND ORDHI=(XXXSSBH,ZZZSSBH,...)

```

Figure 9-1 (Part 2 of 2). Example: Defining a Block Handler and Block Handler Set

---

### Defining Resources to Use a Block Handler Set

BSC cluster control units, devices, and device components can be defined to use block handling routines at designated execution points. Code the following definition statements and keywords to provide NCP with information about the block handler to use and the point at which it executes.

CLUSTER	BHEXEC BHSET EXEC PT3EXEC
TERMINAL	BHEXEC BHSET PT3EXEC
COMP	BHEXEC BHSET PT3EXEC

BHEXEC on the CLUSTER, TERMINAL, and COMP definition statements identifies the block handling routine associated with a device.

BHSET names the block handler set containing the block handling routine. BHSET also specifies whether the block handler set runs without being activated by the access method. If so, the block handler set is activated during initialization of NCP. If not, it must be activated by a request from the access method. You can use BHSET to specify that no block handler set is initially assigned to the station but that one can be assigned dynamically by the access method. For an IBM 3270 operating as a BSC device, VTAM ignores BHSET.

EXEC specifies that the block handler set can be used without being activated by the access method.

PT3EXEC specifies whether a block handler running at point 3 is associated with a device.

**Note:** Device refers to:

- A clustered BSC control unit on the CLUSTER definition statement
- A BSC or start-stop device on the TERMINAL definition statement
- The input or output component of the BSC or start-stop device on the COMP definition statement.

#### Sample Resource Definition for a Block Handler

Figure 9-2 on page 9-7 shows how to define the resources that activate a block handler set.



```
SSGRP1  GROUP LNCTL=SS,  
          BHEXEC=ALL,  
          BHSET=SSBHSET1,  
          PT3EXEC=YES,...  
  
*  
SSLN1   LINE  
*  
S1      SERVICE  
*  
T1      TERMINAL  
*  
C1      COMP  
*  
T2      TERMINAL  
*  
C2      COMP .  
          .  
          .  
*  
T7      TERMINAL BHSET=SSBHSET2  
*  
C7      COMP
```

Figure 9-2. Example: Defining Resources That Use a Block Handler Set



---

## Chapter 10. Dynamic Reconfiguration

Use this chapter only if you define SDLC devices, frame-relay resources, or ESCON peripheral channel links.

Dynamic reconfiguration changes the configuration of a nonswitched SDLC telecommunication link connected to an NCP without having to regenerate NCP. You can add and delete type 1 and type 2 SDLC physical and logical units. You can also add and delete the physical and logical units associated with ESCON links for a peripheral host node (a type 2.1 physical unit). You cannot add links or add and delete BSC and start-stop devices or programmed resources.

---

### Adding and Deleting Dynamically Reconfigurable Resources

The dynamic reconfiguration data set (DRDS) consists of ADD or DELETE definition statements, or both, and their associated PU and LU definition statements.

**Note:** Dynamic reconfiguration using a DRDS is not available for frame-relay resources. Use the permanent dynamic reconfiguration function of VTAM to dynamically alter resources in a frame-relay network. See *VTAM Network Implementation Guide* for more information about the permanent dynamic reconfiguration function.

Code the following definition statements and keywords to provide NCP with information about adding and deleting dynamically reconfigurable resources.

ADD	TO
DELETE	FROM

TO on the ADD definition statement names the link or physical unit to which the new device will be added. Code the ADD definition statement to add a physical unit to an existing link or add a logical unit to a physical unit.

FROM on the DELETE definition statement names the link or physical unit from which the device will be deleted. If a physical unit is deleted from a link, all logical units associated with that physical unit are also deleted. Code the DELETE definition statement to delete a physical or logical unit from an existing link or physical unit.

Each time you change the NCP configuration, define a new DRDS containing only the current modifications. For example, do not add and then delete the same physical unit or logical unit in one DRDS. If you want to delete a device added through dynamic reconfiguration, define a new DRDS to delete it.

If an ADD or DELETE definition statement specifies a link on the TO or FROM keyword, a PU definition statement must follow it. The PU definition statement can then be followed by one or more LU definition statements. If the ADD or DELETE definition statement specifies a physical unit on the TO or FROM keyword, one or more LU definition statements must follow it. See Figure 10-1 on page 10-2 for an example of how to reconfigure a physical unit.

## Defining Physical Unit Resources

**Note:** When deleting a physical unit or logical unit from the configuration, code only the symbol on the respective PU and LU definition statements. If you code any keywords, they are ignored.

For information on defining and using the DRDS with VTAM, see *VTAM Network Implementation Guide*.

### Sample Dynamic Reconfiguration Data Sets

If you want to move PU6 and its associated logical units (LU1 and LU2) from LINE6 to LINE7, code the statements shown in Figure 10-1 in the DRDS.

```
        DELETE FROM=LINE6
PU6     PU
*
        ADD     TO=LINE7
PU6     PU     ...
*
LU1     LU     ...
*
LU2     LU     ...
*
```

Figure 10-1. Example: Defining the Reconfiguration of a Physical Unit

If you want to move only one logical unit (LU1) from PU3 to PU4, code the statements shown in Figure 10-2 in the DRDS.

```
        DELETE FROM=PU3
LU1     LU
*
        ADD     TO=PU4
LU1     LU     ...
```

Figure 10-2. Example: Defining the Reconfiguration of a Logical Unit

---

## Defining Dynamically Reconfigurable Physical Unit Resources

NCP enables you to dynamically change your configuration by adding or deleting telecommunication link devices to maintain system flexibility. See page 16-59 for more information about dynamic reconfiguration for frame-relay devices.

Code the following definition statements and keywords to provide NCP with information about the number of links to be dynamically reconfigured and the devices attached to those links.

```
PUDRPOOL  NUMBER
LINE      MAXPU
SERVICE  MAXLIST
PU        PUDR
```

NUMBER on the PUDRPOOL definition statement defines the number of physical units included in the physical unit pool. The physical unit pool contains empty physical unit control blocks used when new SDLC devices are added to links connected to NCP. NUMBER should define how many devices you expect to add to links connected to your NCP at a later date.

**Note:** You can cause NCP to dynamically create additional physical unit control blocks when needed. See “Dynamically Created Control Blocks” on page 2-10 for more information.

MAXPU on the LINE definition statement specifies how many SDLC devices can be attached to a telecommunication link. MAXPU should define the number of SDLC devices attached to the link plus the number of devices you expect to add to the link at a later date.

MAXLIST on the SERVICE definition statement defines the maximum number of entries needed in the service order table. This value is the number of entries in the service order table plus the number of SDLC devices you expect to add at a later date.

PUDR on the PU definition statement specifies whether the device can be deleted through dynamic reconfiguration. Code PUDR if the SDLC device is not a type 4 physical unit and is attached to a nonswitched link.

### Sample Coding to Dynamically Reconfigure Link Devices

Figure 10-3 shows how to code the dynamic reconfiguration of link devices. This example defines a line that supports up to four dynamically reconfigurable physical units. One of these physical units (P00321A) is explicitly defined.

```

*****
*           DYNAMIC RECONFIGURATION - NCP POOL DEFINITIONS           *
*****
*
*           PUDRPOOL NUMBER=16           16 physical units in physical unit pool
*
*           .
*           .
*           .
*****
*           SDLC LEASED LINE DEFINITIONS                             *
*****
*
*           GA03SDL1 GROUP .
*           .
*           .
*
*           L00321  LINE  MAXPU=4,           4 physical units associated with line
*           .
*           .
*
*           SERVICE ORDER(P00321A),   Order of line service
*           MAXLIST=4                 4 entries in service order table
*
*           P00321A PU  PUDR=YES,       Dynamic reconfiguration can delete PU
*           .
*           .

```

Figure 10-3. Example: Defining the Reconfiguration of Link Devices

---

### Defining Dynamically Reconfigurable Logical Unit Resources

You can dynamically add new logical units to SDLC devices attached to NCP. Code the following definition statements and keywords to provide NCP with information about those logical units to be added or deleted.

LUDRPOOL	NUMILU NUMTYP1 NUMTYP2
PU	MAXLU
LU	LUDR

NUMILU on the LUDRPOOL definition statement defines the number of independent logical units eligible for dynamic reconfiguration. NUMTYP1 and NUMTYP2 define the number of dependent logical units eligible for dynamic reconfiguration. NUMTYP1 specifies the number of dependent logical units for type 1 physical units. NUMTYP2 specifies the number of dependent logical units for type 2 and type 2.1 physical units. The values of NUMILU, NUMTYP1, and NUMTYP2 are used to create empty control blocks in logical unit control block pools. The control blocks get used when new logical units are added to SDLC devices attached to NCP.

#### Notes:

1. The NUMILU, NUMTYP1, and NUMTYP2 keywords each create control blocks in several control block pools. Some of these control blocks are in the same pools, some are not.

For the LUB control block pool, for example, the values of NUMILU, NUMTYP1, and NUMTYP2 are added together to form a single pool of resources. A result of this is that you may be able to dynamically add more logical units for type 2 physical units than what you defined on the NUMTYP2 keyword. This is because the LUBs and the other control blocks created for NUMTYP2 are also created for NUMTYP1. But, you will not be able to dynamically add more logical units for type 1 physical units than what you defined on the NUMTYP1 keyword (see note 2 for an exception). This is because the LTX control block pool is created only for the NUMTYP1 keyword.

See the chapter on control block management in the *NCP and EP Reference* for detailed information on the control blocks created from the NUMILU, NUMTYP1, and NUMTYP2 keywords.

2. You can cause NCP to dynamically create additional logical unit resources to supplement those defined by NUMILU, NUMTYP1, and NUMTYP2 when needed. See “Dynamically Created Control Blocks” on page 2-10 for more information.

MAXLU on the PU definition statement specifies the maximum number of logical units to be associated with an SDLC device. MAXLU should represent the actual number of logical units associated with the SDLC device plus the number of logical units you expect to add to the SDLC device at a later date. MAXLU is not supported if you code VIRTUAL=NO on the GROUP definition statement.

LUDR on the LU definition statement determines whether the logical unit can be deleted from its associated device at a later date.

### Sample Coding for Dynamic Reconfiguration of Logical Units

Figure 10-4 shows a coding sample that provides dynamic reconfiguration of logical units. P00324A is a physical unit definition that will use dynamically reconfigurable logical units. Because there are no logical units explicitly defined under the physical unit, all logical units for this device are defined using dynamic reconfiguration. When VIRTUAL=YES is not coded on the group definition statement, MAXLU cannot be coded for the physical unit.

```

*****
*          DYNAMIC RECONFIGURATION - NCP POOL DEFINITIONS          *
*****
*
*          LUDRPOOL NUMTYP1=12,      12 LUs for type 1 PUs
*          NUMTYP2=12                12 LUs for type 2 PUs
*
*****
*          LINE GROUP DEFINITIONS                                  *
*****
*
*          .
*          .
*          .
*****
*          SWITCHED SDLC LINK TO SDLC DEVICES                    *
*****
*
*          .
*          .
*          .
P00324A  PU      PUTYPE=(1,2)      Physical unit types 1 and 2 supported

```

Figure 10-4. Example: Adding and Deleting Logical Units

## Dynamic Reconfiguration for SDLC 3270 Devices

You can dynamically reconfigure an SDLC type 1 physical unit that is a 3270 device. Code the following definition statement and keyword to provide NCP with information about IBM 3270 devices to be dynamically reconfigured.

```

BUILD      DR3270

```

DR3270 on the BUILD definition statement allows the dynamic reconfiguration function of your NCP to add IBM 3270 Information Display System devices at a later date to links connected to your network.

## Dynamic Reconfiguration for Frame-Relay Devices

You can dynamically reconfigure a frame-relay frame handler support (FHSP) if you code all the definition statements and keywords, except the SERVICE definition statement, described in “Defining Dynamically Reconfigurable Physical Unit Resources” on page 10-2.

## Frame-Relay Internet Devices

If you want to provide NCP with information about NPM data collection for dynamically reconfigured FHSPs, code the following definition statement and keyword.

PUDRPOOL	FRSEDRPU
----------	----------

FRSEDRPU on the PUDRPOOL definition statement specifies the total number of FHSPs that can be added through dynamic reconfiguration and that are eligible for NPM performance data collection. FRSEDRPU is valid only if you specify NPA=(YES,DR) or NPA=(YES,DRTP) on the BUILD definition statement.

**Note:** The second operand is valid only for NCP V7R3.

**3746 Model 900:** 3746 Model 900 frame-relay resources do not use the storage reserved by FRSEDRPU. Therefore, do not include these resources when calculating the value of FRSEDRPU.

---

## Dynamic Reconfiguration for Frame-Relay Internet Devices

You can dynamically reconfigure a frame-relay internet host if you code all the definition statements and keywords, except the SERVICE definition statement, described in “Defining Dynamically Reconfigurable Physical Unit Resources” on page 10-2.

If you want to use dynamic reconfiguration to add internet resources to a frame relay line that does not already have internet resources defined, code the following definition statements and keywords:

LINE	ARPTAB
IPOWNER	NUMDRIF

ARPTAB specifies the maximum number of temporary entries that can exist in the Address Resolution Protocol (ARP) table, at any given time. ARPTAB must be coded to indicate that internet resources can be added through dynamic reconfiguration. The line type determines the proper location for the ARPTAB keyword:

- For a **leased** frame-relay physical line, code ARPTAB on the physical line.
- For a **switched** frame-relay physical line, code ARPTAB on the logical line.

NUMDRIF on the IPOWNER definition statement specifies the number of internet interfaces that can be dynamically reconfigured to this NCP, and how many of the dynamically reconfigured interfaces are eligible for NPM data collection.

### Notes:

1. DYNPOOL coded on the BUILD definition statement might cause the number of dynamically allocated control blocks to exceed the value specified by NUMDRIF, which can affect storage utilization. See the chapter on control block management in the *NCP and EP Reference* for additional information.
2. To dynamically add an internet interface, any IP keywords such as LADDR, METRIC, PROTOCOL, P2PDEST, and SNETMASK should be coded on the PU statement, not on an IPLOCAL statement.



- To dynamically add an internet interface that requires NCP variable subnetting support (multiple internet interfaces to the same network using different subnet masks), you must code VSUBNETS=YES on the BUILD statement in your NCP definition.

---

### Defining NCP Channel Connections from the Host

SSP supports the use of MVS Hardware Configuration Definition (HCD) to provide the capability to define NCP channel connections from the host. An HCD dialog (a set of interactive panels) lets you specify values for the following keywords:

<b>Keyword</b>	<b>Value</b>
PUTYPE	2, 4, or omitted
TIMEOUT	0 (indicating NONE), 20–840 seconds, or omitted
DELAY	Up to one-half the TIMEOUT value. If the TIMEOUT value is 0 or is omitted, the DELAY value can be 0–420 seconds.
MAXBFRU	1–255 or omitted
INBFRS	1–255 or omitted
MAXDATA	1–65535 or omitted
TRANSFR	1–255 or omitted
BFRPAD	0–255 or omitted
TPSFEAT	TCS, TPS, NONE (indicating that the two-processor switch feature is not installed), or omitted

HCD saves the values you enter for these keywords and uses them to automatically configure and activate the connection when the channel is varied online. For more information on these keywords, see *NCP, SSP, and EP Resource Definition Reference*.

Define the first channel connection to the host in the NCP generation definition. You can use HCD to define subsequent connections. If you define a particular channel connection both in the NCP generation definition and through HCD, the HCD values can override the generation definition values. The generation definition values can also be overridden by a user CLIST that uses VTAM.

For additional information on HCD, see *MVS/ESA System Programming Library: Processor and Device Support* and *IBM MVS/ESA Hardware Configuration Definition: Using the Dialog*.



---

## Chapter 11. Routes between Subareas

Data travels from subarea to subarea in the network along physical and logical paths called routes. A physical connection between two subareas is called an explicit route, which can also span several subarea-to-subarea connections to create a communication path from one subarea to a distant subarea.

A logical connection between two subareas is called a virtual route. Each virtual route in the network is assigned to an explicit route and a reverse explicit route. The virtual route assumes the physical characteristics of the associated explicit route. Virtual routes are defined to the access method and, in some cases, to NCP.

The following sections explain how to define explicit and virtual routes to NCP. See *VTAM Network Implementation Guide* or *TCAM Networking Installation Guide* for information about defining explicit and virtual routes to the access method. Before attempting to define routes in your network, it might be useful to read the information on routing contained in *SNA Technical Overview*.

---

### Transmission Groups Between Subareas

A transmission group consists of one or more telecommunication links used to transfer data between subareas or between NCP and the access method. Messages are automatically distributed among the lines that make up the transmission groups between NCPs, causing more data to be passed simultaneously between NCPs and permitting data to be rerouted if one of the lines fails.

A maximum of 255 transmission groups can be defined between two subareas in a native or non-native network, but the total number of transmission groups that can be active is limited by the ERLIMIT keyword and the PATH definition statement values for ERn and VRn. When you code a value for ERLIMIT, you can define 8 or 16 explicit routes between two subareas. Transmission groups are defined using the TGN keyword on the PU definition statement, which is described in "Transmission Groups" on page 12-15.

---

### Explicit Routes

An explicit route is a connection from one subarea to another using transmission group lines. A subarea can communicate with an adjacent subarea over a single transmission group or it can communicate with a distant subarea through an interconnection of subarea nodes and transmission groups.

You can define up to 16 explicit routes between one subarea in the network and a destination subarea. Explicit routes are numbered from 0 through 15, depending on the maximum number of routes specified. Figure 11-1 on page 11-2 shows five subareas in communication with one another over explicit routes. In this illustration, a subarea can communicate with an adjacent subarea, or a subarea can communicate with a distant subarea over an explicit route that passes through other subareas. Data is assigned to travel a particular route when the session between a resource in an origin subarea and a resource in a destination subarea is established. The same route may not be selected each time a session between the same subareas is established.

## Explicit Routes

Data travels over an explicit route in one direction; it travels over a virtual route in both directions. Because virtual routes are assigned to explicit routes, for every explicit route defined to carry data in one direction, another explicit route, called the reverse explicit route, must be defined to carry data in the other direction. Both explicit routes use the same set of subareas and transmission groups in both directions; however, they do not have to have the same explicit route number.

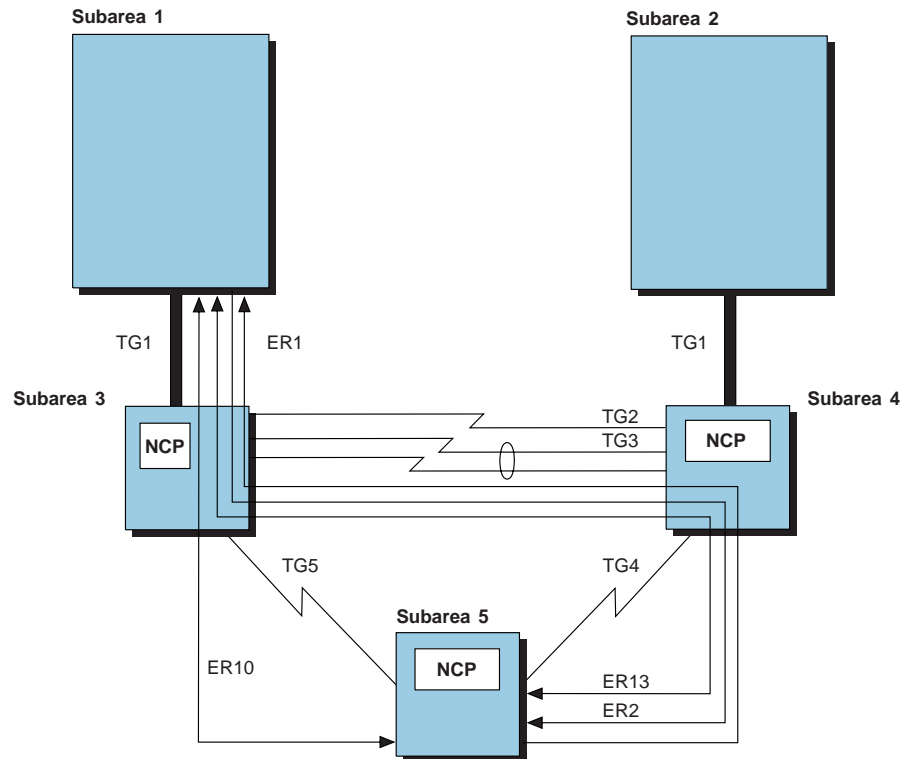

Figure 11-1. Explicit Routes to Connect Five Subareas in One Network

Notice the following relationships among the different subareas in Figure 11-1:

- NCP subarea 5 communicates with VTAM subarea 1 over explicit route 1 (ER1). Data travels from NCP subarea 5 to NCP subarea 4 over transmission group 4 (TG4), from NCP subarea 4 to NCP subarea 3 over TG2, and finally, from NCP subarea 3 to the destination subarea, VTAM subarea 1, over TG1.
- NCP subarea 5 can also communicate with VTAM subarea 1 (the final destination) over ER13 and ER10. ER13 is almost identical to ER1, except that data travels from NCP subarea 4 to NCP subarea 3 over TG3 instead of over TG2. Data travels over ER10 from NCP subarea 5 to NCP subarea 3 over TG5, and from NCP subarea 3 to VTAM subarea 1 over TG1.
- Data travels from VTAM subarea 1 to NCP subarea 5 over ER2. Data along this route travels from VTAM subarea 1 to NCP subarea 3 over TG1, from NCP subarea 3 to NCP subarea 4 over TG2, and finally, from NCP subarea 4 to NCP subarea 5 over TG4, using the same set of subareas and transmission groups as ER1 from NCP subarea 5 back to VTAM subarea 1. ER13, however, is defined as having the same explicit route number in both directions.
- Data traveling along ER13 from VTAM subarea 1 to NCP subarea 5 uses the same subareas and transmission groups as data traveling along ER13 from

NCP subarea 5 to VTAM subarea 1. Likewise, ER10 from VTAM subarea 1 to NCP subarea 5 has the same explicit route number as ER10 from NCP subarea 5 to VTAM subarea 1. It, too, uses the same set of subareas and transmission groups in both directions.

- NCP subarea 4 has three explicit routes passing through it. They are ER1, ER2, and ER13. The destination subarea for NCP subarea 4 over ER1 is VTAM subarea 1; the destination subarea over ER2 is NCP subarea 5. Data travels on ER13 in two directions. For data traveling in one direction, the destination subarea for NCP subarea 4 over ER13 is VTAM subarea 1; for data traveling in the other direction, the destination subarea is NCP subarea 5. The same relationship holds true for NCP subarea 3 over ER10.
- Because an explicit route originates in NCP subarea 5 and no routes pass through it, the only destination subarea for data traveling from NCP subarea 5 over ER1 is VTAM subarea 1.

## Guidelines for Defining Explicit Routes

Use the following guidelines when you define explicit routes:

- You can define up to 16 explicit routes between an origin subarea and a destination subarea. You can assign a number from 0 to 15 to an explicit route.
- For a particular explicit route, use the same explicit route number in every PATH definition statement that defines its destination subarea.
- For every explicit route defined to carry data in one direction, define a reverse explicit route to carry data in the other direction.
- Between the origin subarea and a destination subarea, you can use the same explicit route number to define the forward data flow and the reverse data flow, or you can use different explicit route numbers to define the forward and reverse data flows.
- Do not use the same explicit route number to define the same direction of data flow for multiple routes between the same origin subarea and the same destination subarea.
- For a given destination subarea, you can code only one PATH definition statement in each NCP definition; code all explicit routes or segments of explicit routes to that given destination subarea on the same PATH definition statement.
- Many explicit routes can use the same transmission group as part of their routes; if a transmission group becomes inoperative, all explicit routes using that transmission group also become inoperative.
- When defining an explicit route for backup, use different subareas and transmission groups wherever possible for the primary route and the backup route to ensure the backup route will be available if the primary route becomes inoperative due to the failure of a physical component of the route.
- Explicit routes that are part of a cross-network path are defined independently in each network the cross-network path travels through. The data flowing between subareas in separate networks is not likely to travel on the same-numbered explicit routes in each network. Therefore, you do not have to specify the same explicit route number from network to network. See Chapter 14 and “Defining Cross-Network Paths” on page 14-15 for more information.

### Defining Explicit Routes

Code the following definition statements and keywords to provide NCP with information about how to define an explicit route.

BUILD	ERLIMIT
NETWORK	ERLIMIT
PATH	DESTSA ER $n$

#### BUILD

ERLIMIT on the BUILD definition statement defines the maximum number of explicit routes supported between subarea pairs in the native network.

#### NETWORK

ERLIMIT on the NETWORK definition statement defines the maximum number of explicit routes supported between subarea pairs in a non-native network. You can define as many as 16 explicit routes; however, if you omit ERLIMIT, the default is 8 explicit routes. If you do not code ERLIMIT on the NETWORK definition statement, NCP uses the value coded on the BUILD definition statement.

#### PATH

DESTSA on the PATH definition statement identifies the subarea address of a destination subarea that is the end point in an explicit route. The destination subarea can be either an access method or another NCP. Multiple destination subareas can be defined on one PATH definition statement; however, it is recommended that each destination subarea be identified with a unique path definition statement.

ER $n$  defines the number assigned to each explicit route that either originates in or passes through NCP on its way to the destination subarea specified by DESTSA on the PATH definition statement. Identify the adjacent subarea that will forward data over the explicit route to the destination subarea, the transmission group number, and the flow-control thresholds.

The explicit route number can be a value from 0 to 15. ER8 through ER15 are valid only if you specify 16 explicit routes on ERLIMIT on the BUILD definition statement. You can specify the low, medium, high, and total flow-control thresholds that detect transmission group congestion. When a threshold is exceeded, flow-control congestion indicators are included in the PIUs sent to destination subareas, notifying these destination subareas of the congestion situation. Appropriate flow-control actions then take place.

**APPN HPR:** The total flow-control threshold is also used as the limit on the number of bytes of APPN HPR data that can be queued on the transmission group at one time. When the threshold is exceeded, NCP discards additional APPN HPR data that arrives. This causes the RTP endpoints to reduce the rate at which they send APPN HPR data into the subarea network of the composite ANR node.

The ER $n$  keywords define entire routes through the network. However, these routes are made up of segments that must be defined in each subarea that originates a route, or functions as an intermediate subarea along the explicit route.

### Sample Definitions of Explicit Routes

Figure 11-2 shows explicit routes between NCP subarea 5 and VTAM subarea 1.

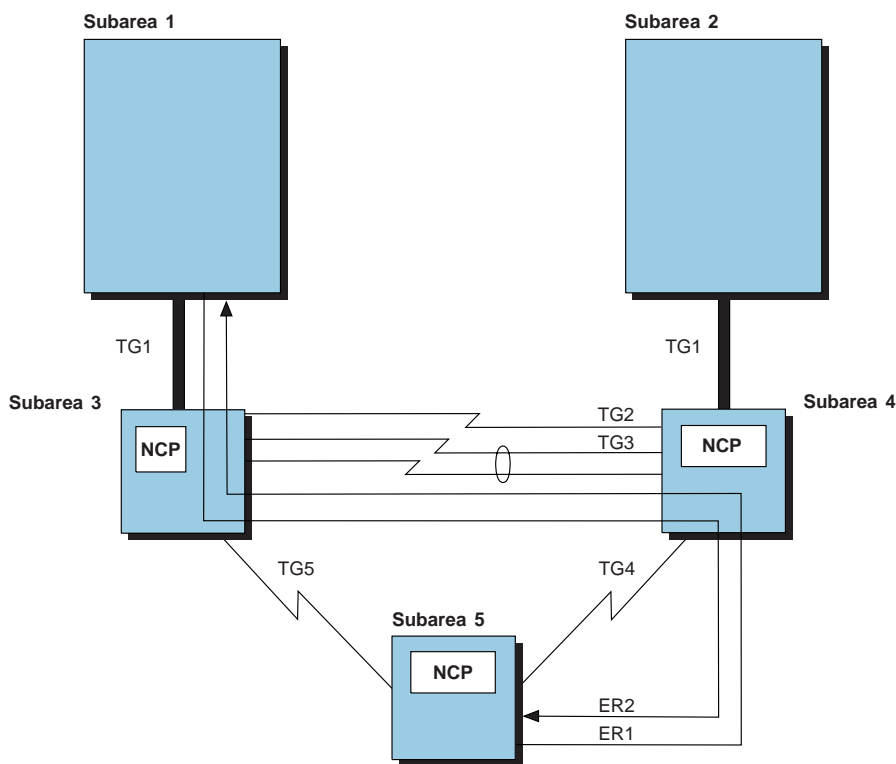

Figure 11-2. Explicit Routes between NCP Subarea 5 and VTAM Subarea 1

Figure 11-3 shows the five NCP PATH definition statements and one VTAM PATH definition statement required to define the explicit routes shown in Figure 11-2.

Subarea 5 to Subarea 1		Subarea 1 to Subarea 5	
In NCP Subarea 5:	PATH DESTSA=1, ER1=(4,4)	In VTAM Subarea 1:	PATH DESTSA=5, ER2=(3,1)
In NCP Subarea 4:	PATH DESTSA=1, ER1=(3,2)	In NCP Subarea 1:	PATH DESTSA=5, ER2=(4,2)
In NCP Subarea 3:	PATH DESTSA=1, ER1=(1,1)	In NCP Subarea 4:	PATH DESTSA=5, ER2=(5,4)

Figure 11-3. Example: Defining Explicit Routes between NCP Subarea 5 and VTAM Subarea 1

The PATH definition statements in the left column define an explicit route from NCP subarea 5 to VTAM subarea 1, identified as ER1. The PATH definition statements in the right column define an explicit route from VTAM subarea 1 to NCP subarea 5, identified as ER2. A virtual route handles data traveling in either direction using the same set of subareas and transmission groups in both directions when you code PATH statements this way. In NCP subarea 5, data is defined as traveling over ER1 from NCP subarea 5 to an adjacent subarea, NCP subarea 4, over TG4 (ER1=(4,4)). In NCP subarea 4, the data is routed over ER1 from NCP subarea 4 to an adjacent subarea, NCP subarea 3, over TG2 (ER1=(3,2)). In

## Explicit Routes

NCP subarea 3, the data is routed to the adjacent subarea (which also is the destination subarea), VTAM subarea 1, over TG1 (ER1=(1,1)). Follow ER2 from VTAM subarea 1 to NCP subarea 5 in the same way by looking at the path definitions in the right column. An explicit route is defined as an entire route when you give it the same explicit route number in *every* PATH definition statement that defines its destination subarea.

Figure 11-4 and Figure 11-6 on page 11-7 illustrate how a segment of one explicit route can often serve as a segment of another explicit route, provided the other explicit route is going to the same destination subarea. Figure 11-4 shows an explicit route from VTAM subarea 2 to VTAM subarea 1.

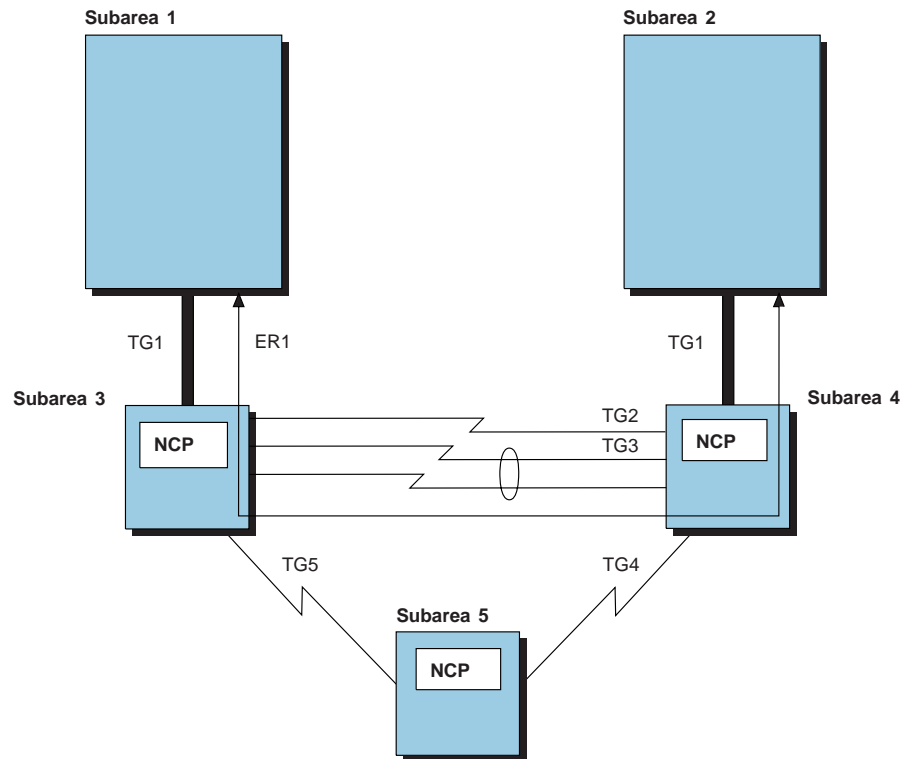

Figure 11-4. Explicit Route between VTAM Subarea 2 and VTAM Subarea 1

The explicit route shown in Figure 11-4 shares the same definitions in NCP subarea 4 and NCP subarea 3 as ER1 shown in Figure 11-2 on page 11-5. If these two explicit routes were defined in the same network, you would not need to code duplicate PATH definition statements for ER1 connecting NCP subarea 5 to VTAM subarea 1, and for ER1 connecting VTAM subarea 2 to VTAM subarea 1 when you define the NCPs in subareas 3 and 4.

Figure 11-5 on page 11-7 shows how to code the PATH definition statements for the explicit route shown in Figure 11-4. Notice that the PATH definition statements to destination subarea 1 in NCP subareas 3 and 4 are identical to the PATH definition statements coded in Figure 11-3 on page 11-5.



Subarea 2 to Subarea 1		Subarea 1 to Subarea 2	
In VTAM Subarea 2: PATH	DESTSA=1, ER1=(4,1)	In VTAM Subarea 1: PATH	DESTSA=2, ER1=(3,1)
In NCP Subarea 4: PATH	DESTSA=1, ER1=(3,2)	In NCP Subarea 3: PATH	DESTSA=2, ER1=(4,2)
In NCP Subarea 3: PATH	DESTSA=1, ER1=(1,1)	In NCP Subarea 4: PATH	DESTSA=2, ER1=(2,1)

Figure 11-5. Example: Defining an Explicit Route between NCP Subarea 2 and VTAM Subarea 1

Figure 11-6 shows a different explicit route, ER2, connecting VTAM subarea 2 to VTAM subarea 1. If this explicit route existed in the same network as ER1 shown in Figure 11-4 on page 11-6, it would be defined on the same PATH definition statements coded in Figure 11-5; however, it is intended to be a second explicit route between subareas 1 and 2.

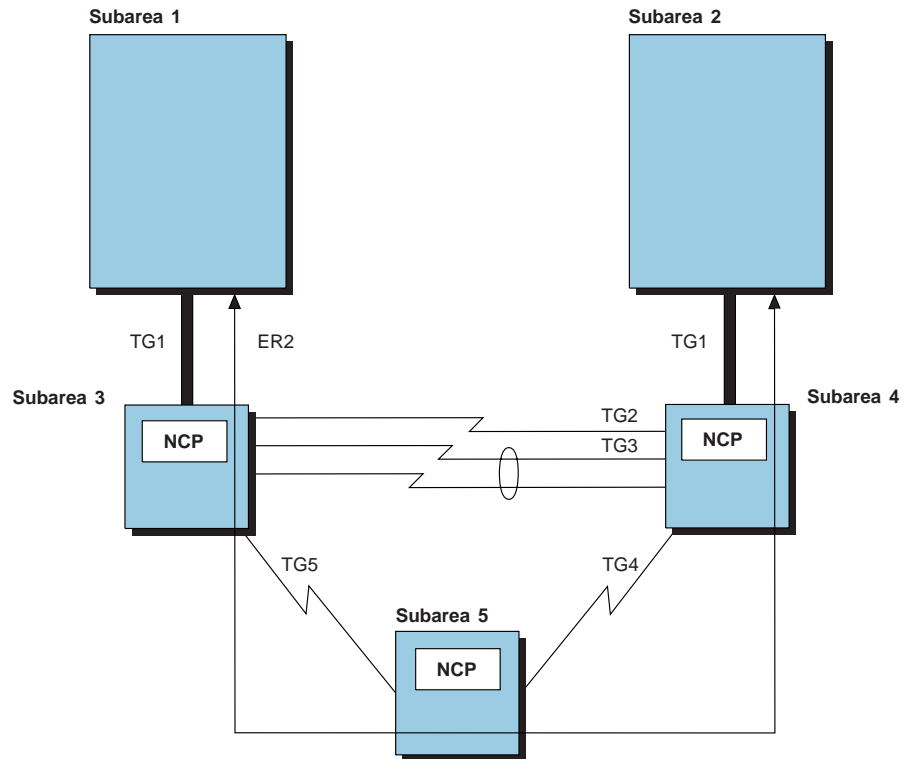

Figure 11-6. Explicit Route ER2 between VTAM Subarea 2 and VTAM Subarea 1

## Explicit Routes

Figure 11-7 shows you how to code ER2, shown in Figure 11-6 on page 11-7.

Subarea 2 to Subarea 1		Subarea 1 to Subarea 2	
In VTAM Subarea 2:	PATH DESTSA=1, ER2=(4,1)	In VTAM Subarea 1:	PATH DESTSA=2, ER2=(3,1)
In NCP Subarea 4:	PATH DESTSA=1, ER2=(5,4)	In NCP Subarea 3:	PATH DESTSA=2, ER2=(5,5)
In NCP Subarea 5:	PATH DESTSA=1, ER2=(3,5)	In NCP Subarea 5:	PATH DESTSA=2, ER2=(4,4)
In NCP Subarea 3:	PATH DESTSA=1, ER2=(1,1)	In NCP Subarea 4:	PATH DESTSA=2, ER2=(2,1)

Figure 11-7. Example: Defining Explicit Route ER2

Figure 11-8 shows the four explicit routes shown in Figure 11-2, Figure 11-4, and Figure 11-6 together in one network. Notice that ER1 and ER2 from VTAM subarea 2 to VTAM subarea 1 have the same explicit route numbers in both directions.

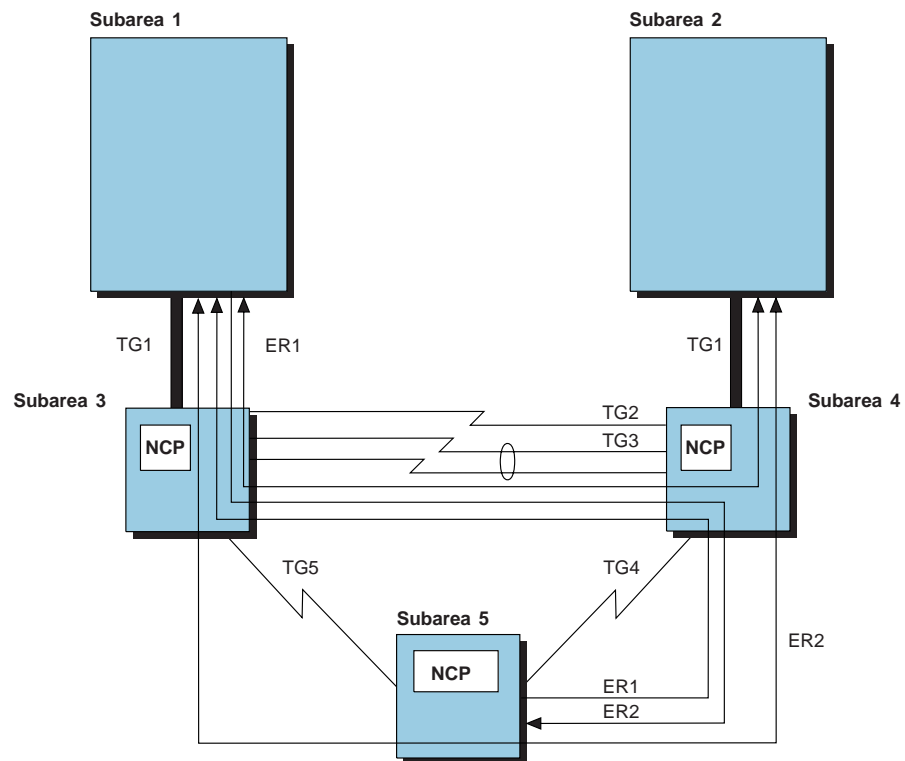

Figure 11-8. Four Explicit Routes in One Network

Figure 11-9 shows the PATH definition statements for all the routes shown in Figure 11-8 on page 11-8. Part 1 shows the explicit routing paths from VTAM subarea 1 to destination subareas 2 and 5. Part 2 shows the explicit routing paths from VTAM subarea 2 to destination subarea 1 and from NCP subarea 5 to destination subarea 1. In all other respects, the two parts of the example are identical.

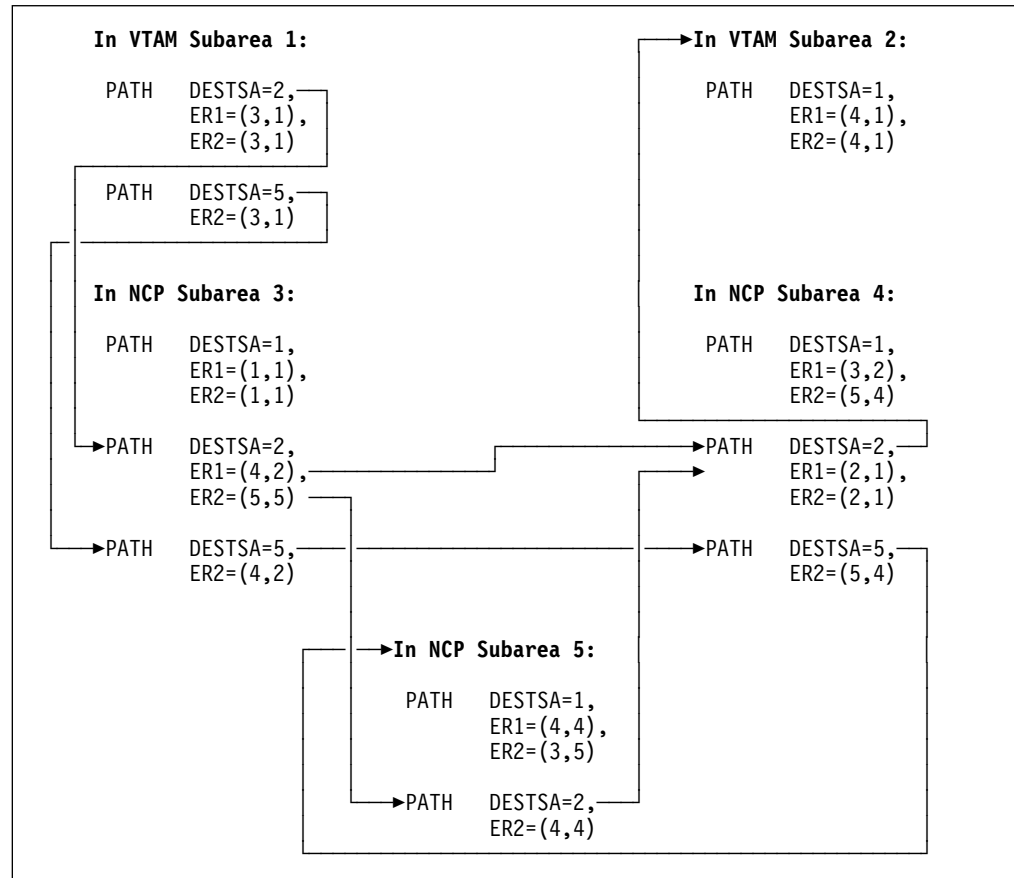

Figure 11-9 (Part 1 of 2). Example: Defining Four Explicit Routes in One Network

## Virtual Routes

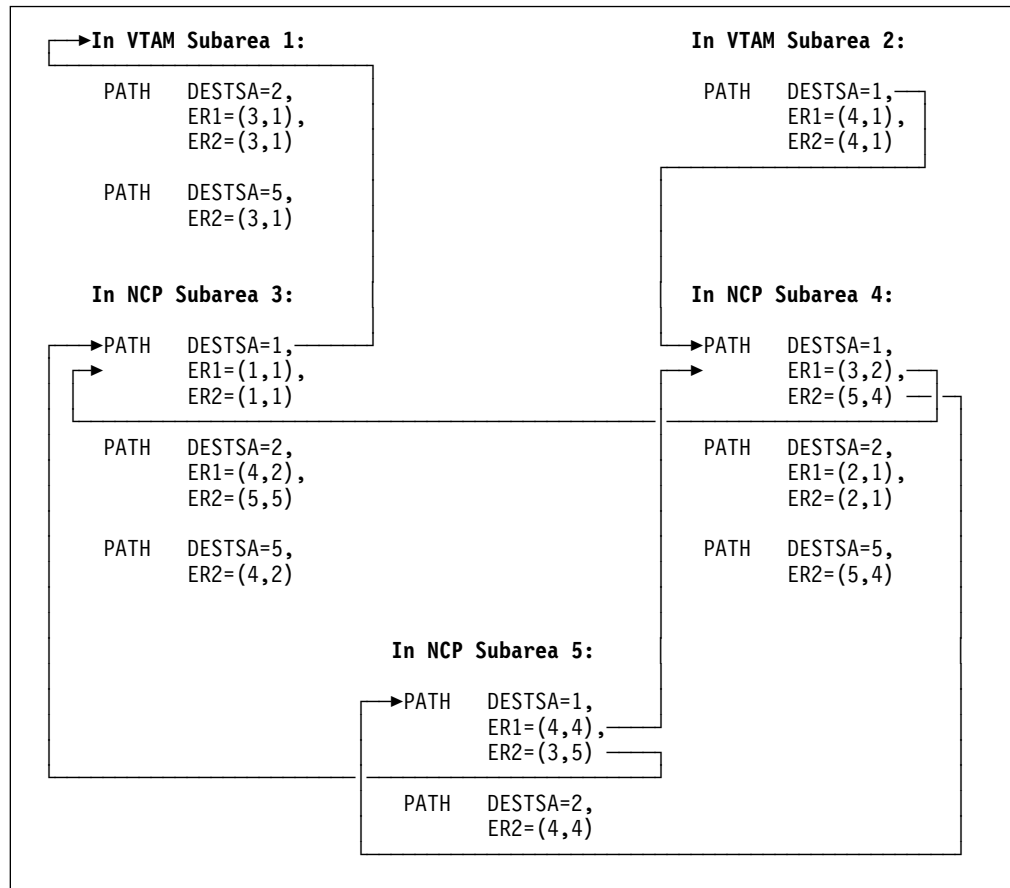

Figure 11-9 (Part 2 of 2). Example: Defining Four Explicit Routes in One Network

## Virtual Routes

A virtual route is a logical connection between an origin subarea and a destination subarea. Virtual routes are assigned to the explicit routes that transmit data from the origin to the destination. A virtual route takes on the physical characteristics of the explicit route to which it is assigned.

Virtual routes have assigned data flow-control characteristics, such as transmission priorities and pacing specifications. Transmission priorities are assigned to virtual routes in class-of-service tables defined in the access method. Pacing specifications for virtual routes are defined to the access method and to NCP. A virtual route, and the explicit route or pair of explicit routes it is assigned to, is selected for a particular session based on the way you define your class-of-service tables. See the appropriate VTAM installation and resource definition manual or *TCAM Networking Installation Guide* for information on defining class-of-service tables.

Define virtual routes if your NCP activates routes. An NCP activates routes when it performs one of the following activities:

- It functions as a gateway NCP (for more information about gateway NCPs and interconnected networks, see Chapter 14).
- It supports the type 2.1 peripheral node PLU.
- It works with the IBM Network Routing Facility (NRF).
- It works with the IBM Non-SNA Interconnection (NSI).

Code the following definition statement and keywords to provide NCP with information about a virtual route in your network that originates, terminates, or passes through your NCP and how to manage the virtual connection and its performance.

PATH	VR <i>n</i> VRPWS <i>nm</i>
------	--------------------------------

VR*n* on the PATH definition statement defines a virtual route to be assigned to an explicit route defined by the same PATH definition statement. Code a VR*n* keyword for each virtual route to be defined on a PATH definition statement. They are numbered VR0 through VR7 and correspond directly to the assigned explicit route number.

Use the following guidelines to assign virtual routes in NCP:

- You can assign a number from 0 to 7 as a virtual route number.
- You can assign many virtual routes to the same explicit route. If an explicit route becomes inoperative, the virtual routes using it are no longer available for session traffic.
- Do not assign the same virtual route to more than one explicit route between an origin subarea and a destination subarea.
- If you define a virtual route between your NCP and a subarea that can also activate the same virtual route, assign the same virtual route number to:

The explicit route in the origin subarea that defines the route's forward data flow

The explicit route in the destination subarea that defines the route's reverse data flow.

VRPWS*nm* specifies the minimum and maximum virtual route pacing window sizes for high-speed or long-delay transmission facilities (for example, satellites) for the virtual routes. Valid values for *n* are 0 to 7. For each virtual route, you can code 0, 1, or 2 for an *m* value to establish three levels of priority for minimum and maximum virtual route pacing window sizes.

### Sample Definition of Virtual Routes

Figure 11-10 shows a virtual route assigned to explicit routes.

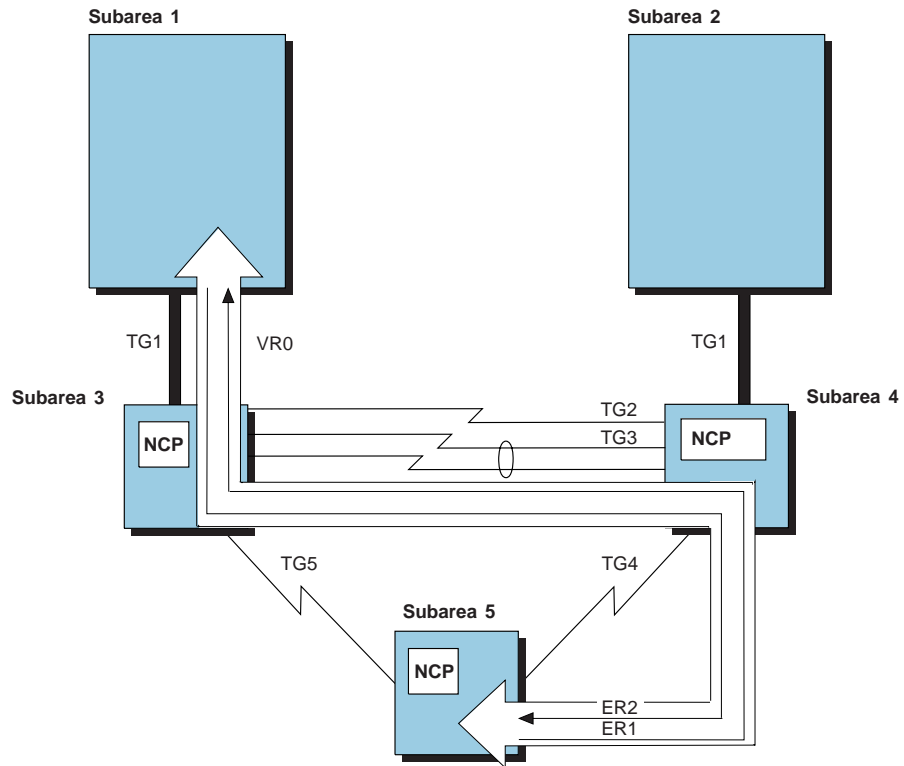

Figure 11-10. Virtual Route between NCP Subarea 5 and VTAM Subarea 1

Figure 11-11 shows how to code the virtual route shown in Figure 11-10. VR0 is assigned to ER1 on the NCP side and to ER2 on the VTAM side.

Subarea 5 to Subarea 1		Subarea 1 to Subarea 5	
In NCP Subarea 5:	PATH DESTSA=1, ER1=(4,4), VR0=1	In VTAM Subarea 1:	PATH DESTSA=5, ER2=(3,1), VR0=2
In NCP Subarea 4:	PATH DESTSA=1, ER1=(3,2)	In NCP Subarea 1:	PATH DESTSA=5, ER2=(4,2)
In NCP Subarea 3:	PATH DESTSA=1, ER1=(1,1)	In NCP Subarea 4:	PATH DESTSA=5, ER2=(5,4)

Figure 11-11. Example: Defining a Virtual Route between NCP Subarea 5 and VTAM Subarea 1

## Dynamic Path Update

The dynamic path update function enables you to delete, add, and change entries in the explicit routing tables of one or more NCPs without disrupting network operation. Dynamic path update performs the following functions:

- Delete               Deletes an explicit route entry if it is defined and not operational.
- Add or Replace    Adds an explicit route entry if one does not exist or replaces it if it is defined and not operating.

These dynamic path update functions enable you to define a transmission group dynamically, change transmission priority thresholds of a transmission group, and change or add explicit-route-to-virtual-route mapping and virtual route pacing window size.

VTAM allows dynamic path update members to be filed in the VTAM definition library. These dynamic path update members are activated by a VTAM operator command or by including the member name in the PCCU definition statement in the NCP generation definition. See *VTAM Network Implementation Guide* for more information about using the dynamic path update function.

Code the following definition statements and keywords to include the dynamic path update function in your NCP generation definition and to provide NCP with information about how to manage the updates to the explicit routing table.

BUILD	PATHEXT TGBXTRA VRPOOL
NETWORK	PATHEXT TGBXTRA
PCCU	NEWPATH

PATHEXT on the BUILD definition statement generates extra transit routing table rows (and explicit route-to-user route-mapping list rows) for a native network.

PATHEXT on the NETWORK definition statement generates extra table rows for a non-native network. Each extra transit routing table row causes one destination subarea to be defined during a dynamic update. This destination subarea appears in the dynamic path update members in VTAM rather than on the PATH or NETWORK definition statement in the NCP generation definition.

TGBXTRA specifies the number of extra transmission group control blocks generated after processing all the PATH definition statements in the network. Code TGBXTRA on the BUILD definition statement for the native network. Code TGBXTRA on the NETWORK definition statement for a non-native network. Each extra transmission group control block (TGB) allows one pair (adjacent subarea, transmission group number) to be defined during dynamic update. This pair appears with the dynamic path update members rather than on the PATH definition statement in the NCP generation definition.

## Mixed-Level Networks

VRPOOL defines the number of entries in the virtual route pool for your NCP. VRPOOL enables you to specify the number of extra rows in the flow control parameter table. Each extra table row causes one virtual route window size specification to be defined during a dynamic update. This virtual route window size specification appears with the dynamic path update members in VTAM rather than on a PATH definition statement in the NCP generation definition.

Consult the *NCP, SSP, and EP Resource Definition Reference* for specific instructions on how to determine the correct values to code on PATHEXT, TGBXTRA, and VRPOOL. If you define excessive values, NCP storage can be wasted.

NEWPATH on the PCCU definition statement is a VTAM-only keyword representing the path table update members. See *VTAM Customization* for a complete description of NEWPATH.

**Note:** After you make the dynamic path update for NCP paths, you can place the new PATH definition statements that were included in the dynamic path update member in the NCP generation definition for reference. If you do this, be sure to remove NCPPATH statements and any DELETER keywords on PATH definition statements before you run your next NCP generation. Refer to the VTAM manuals for information about NCPPATH and DELETER.

### Sample Definition of Dynamic Path Update

Figure 11-12 shows how to define dynamic path update to NCP.

```

DNETID  BUILD  PATHEXT=10,      10 extra routing table rows
          TGBXTRA=6,          6 extra transmission group CBs
          VRPOOL=30           30 entries in virtual route pool
*
          .
          .
          .
*****
*                               NON-NATIVE NETWORK B                               *
*                                                                           *
*   - EXTRA ROUTING TABLE ENTRIES SO THAT DYNAMIC PATH UPDATE             *
*   CAN BE USED TO ADD PATHS TO NETB NETWORK                               *
*****
NETB    NETWORK  PATHEXT=2,      2 extra routing table rows for NETB
          TGBXTRA=3             3 extra transmission groups for NETB
```

Figure 11-12. Example: Defining Dynamic Path Update

---

## Defining Routes for Mixed-Level Networks

A mixed-level network contains NCP nodes supported by different releases of NCP. When you define a mixed-level network, you must be particularly attentive to explicit route definition, request/response units, and request/response unit filtering, because different releases of NCP support different numbers of explicit routes. Refer to *NCP and EP Reference* for examples of network routing with a mixed-level network.



---

## Using IBM Network Design Products to Define Routes

The Network Traffic Analyzer (NTA) service calculates the correct virtual route parameter settings and helps optimize your network data flow. When you define transmission group flow-control thresholds and virtual route window sizes with optimum values, you can significantly affect the performance of your network. The correct value for these settings is determined by your network configuration and data flow. With NTA, you can identify SNA traffic congestion problems in the network. The NTA expert system assists in network tuning by recommending actions to optimize virtual route performance. Your IBM representative can offer advice concerning this service offering.

IBM Network Design and Analysis (NETDA) is a networking systems product that assists in the definition and optimization of SNA networks. It provides network definition, availability analysis, performance analysis, and optimal route selection. It selects primary and backup routes based on capacity and defined traffic load. For more information about NETDA, consult *Network Design and Analysis General Information*.

The IBM Route Table Generator (RTG) simplifies network definition by selecting routes and generating PATH definition statements based on your input about network resources. RTG selects the most direct route, the connecting subareas and nodes, and the quality and speed of transmission. Additional information about RTG is found in *Introduction to the Routing Table Generator*.



---

## Chapter 12. Connections between Subarea Nodes

This chapter describes the relationship of NCP with other type 4 or type 5 nodes in the network, including an adjacent NCP or VTAM. It shows you how to define SDLC links to subareas in the network, how to define point-to-point or multipoint link connections, and how to use the casual connection function, which connects two NCPs, two VTAMs, or a VTAM and an NCP as SNA type 2.1 nodes. You can also define Token-Ring, frame-relay, and ISDN subarea connections, which are described in detail in Chapter 6, Chapter 16, and Chapter 7, respectively.

---

### Subarea Links and Link Stations

SDLC subarea links can connect the following network nodes:

- NCP to NCP
- NCP to VTAM
- NCP to any number of network nodes, if one is a type 4 or type 5 node.

There are two types of SDLC subarea links, point-to-point and multipoint. Point-to-point subarea links connect two NCPs or an NCP and a VTAM. Multipoint subarea links connect an NCP to any number of subarea nodes.

Each NCP connected to another NCP by an SDLC subarea link is identified as a link station. A link station is a logical combination of hardware and software within the communication controller that provides an attachment point and control for a subarea link. One exists at both ends of each subarea link connecting two NCPs, even if the link belongs to a multilink transmission group. Figure 12-1 shows three subarea links with a link station at each end of each subarea link.

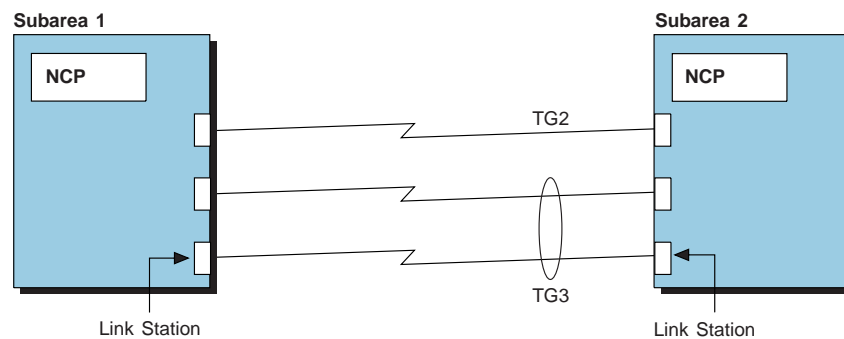

Figure 12-1. Link Stations at Ends of Subarea Links

When you define the link stations in the communication controller where your NCP resides, you provide a logical connection to the NCP in an adjacent controller. For example, in Figure 12-1, when you define NCP subarea 1, you define the link stations in NCP subarea 1 in a logical relationship with NCP subarea 2. Likewise, when you define NCP subarea 2, you define the link stations in NCP subarea 2 in a logical relationship to NCP subarea 1.

### Point-to-Point Subarea Links

Defining SDLC point-to-point subarea links enables one NCP to connect to another NCP. The NCP at each end of a point-to-point subarea link is the primary NCP when it initiates polling; it is the secondary NCP when it is polled. The role of each NCP connected by point-to-point subarea links is determined by defining an explicit role or by defining the role to be configurable. Configurable point-to-point subarea links enable the system to determine whether an NCP is primary or secondary when a communication link is established. At SDLC CONTACT (XID) time, NCPs exchange subarea addresses and additional information to ensure compatibility.

An NCP contacting another NCP is the primary NCP if it has the higher subarea address; it is the secondary NCP if it has the lower subarea address. In some cases, an NCP connected to two NCPs over separate lines can be the primary NCP when communicating with one and the secondary NCP when communicating with the other. See “Defining Configurable Point-to-Point Subarea Links” on page 12-8 for more information.

You can define the role of an NCP to be primary or secondary in the NCP system generation definition by coding MODE on the GROUP definition statement and SDLCST on the LINE definition statement. See “Defining Nonconfigurable Point-to-Point Subarea Links” on page 12-10 for more information.

### Multipoint Subarea Links

Defining multipoint subarea links enables NCP to connect to more than one other NCP over the same link. When you code the system generation definition for a multipoint subarea link, define one NCP as primary and all others as secondary. Each secondary NCP can communicate only with the primary NCP. The primary NCP can communicate with all of the secondary NCPs; therefore, the primary NCP becomes the source of all communication along the subarea link. Figure 12-2 on page 12-3 illustrates a multipoint subarea link in a network.

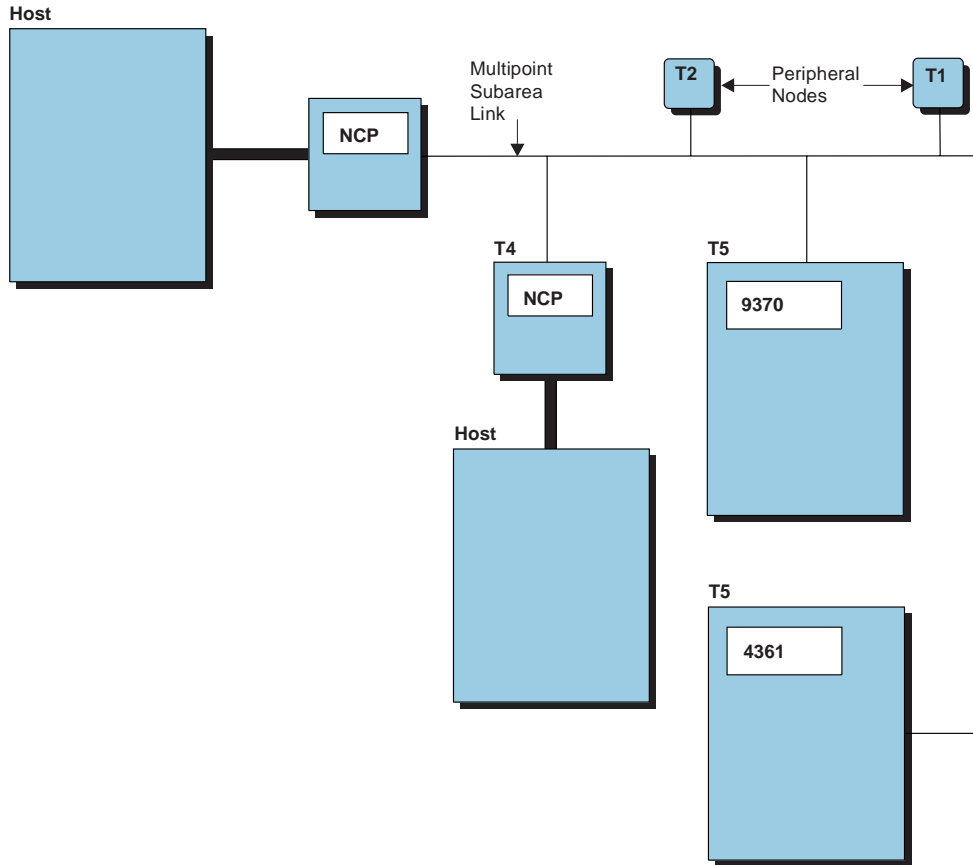

Figure 12-2. Multipoint Subarea Link

## Defining SDLC Subarea Links

Code the following definition statements and keywords to provide NCP with information about how to manage point-to-point and multipoint SDLC subarea links, improve performance, and recover from errors. See “Nonswitched Telecommunication Links” on page 5-1 and “Switched Links” on page 5-4 for additional information.

## Subarea Links and Link Stations

SDLCST	GROUP MAXOUT MODE PASSLIM PAUSE RETRIES SERVLIM TADDR
GROUP	ACTIVTO MODE RNRLIMIT
LINE	CONFIG DUPLEX SDLCST TADDR TRANSFR
PU	ADDR BLOCK MAXDATA MODULO NPACOLL PIUCHECK <sup>1</sup> PUTYPE TGN

<sup>1</sup> Supported starting with NCP V7R7.

### SDLCST

The SDLCST definition statement is used exclusively to define a point-to-point SDLC subarea link. SDLCST defines one entry (set of parameters) about your NCP in a selection table used by any subarea link connecting your NCP to another NCP. SDLCST definition statements define the primary or secondary role of the NCP on each side of a subarea link. Code two SDLCST definition statements when you define configurable point-to-point subarea links. One SDLCST definition statement defines NCP when executing in the primary mode; the second SDLCST definition statement defines NCP when executing in the secondary mode. Omit the SDLCST definition statement and its keywords when you define multipoint subarea links.

GROUP on the SDLCST definition statement identifies the name of the GROUP definition statement that describes either a primary or a secondary subarea node.

MAXOUT specifies the maximum number of frames NCP is to receive from the adjacent NCP before a response is required. MAXOUT values are exchanged by configurable NCPs during the contact procedure when primary and secondary roles are assigned. The secondary NCP uses the MAXOUT value of the primary NCP as the number of frames to send before an acknowledgment is required. The primary NCP uses the MAXOUT value of the secondary NCP as the number of frames to send before an acknowledgment is required. See "Sample Definitions of

Configurable Point-to-Point Subarea Links” on page 12-8 for more information on how to code a value for MAXOUT when NCPs have the same MODULO or a different MODULO value.

MODE specifies whether your NCP is to be the primary NCP or the secondary NCP.

PASSLIM defines the number of consecutive PIUs or PIU segments that an NCP is to send at one time to the adjacent NCP.

PAUSE specifies the average duration of the polling cycle for primary or secondary NCPs. In a primary NCP, if a polling cycle equals or exceeds the PAUSE limit, the next polling cycle begins immediately. If the polling cycle is shorter than the PAUSE limit, the beginning of the next polling cycle is deferred until the PAUSE time has elapsed.

### Notes:

1. For large subarea configurations, the PAUSE limit for a secondary NCP should be at least 0.5 seconds.
2. You can improve performance of HPTSS lines by defining a pause of at least one second for a secondary NCP.
3. For improved performance, code different values for the primary and secondary NCPs.

RETRIES specifies the number of attempts NCP is to make to recover from errors that occur during transmission over the subarea link to an adjacent NCP. An error condition occurs when NCP does not receive a positive indication that a frame it sends is received by the adjacent NCP. NCP continues to retransmit the frame until the frame is successfully received or the number of retries you define for this keyword has been attempted. If an error occurs while NCP is receiving data from the adjacent NCP over a duplex link, it sends the adjacent NCP a command that causes it to retransmit all frames starting with the frame in error. It repeats this command until one of the following is true:

- It successfully receives the frame.
- It repeats the receive operation the number of times you specify for RETRIES.
- The adjacent NCP sends an abnormal response (for example, a request for initialization).

If an error occurs while NCP is receiving data from the adjacent NCP over a half-duplex link, the error frame is rejected by the next receive (NR) count of a poll or poll response.

SERVLIM determines how often NCP interrupts its regular scans of the service order table, during normal processing of the stations attached to the link, to make a special scan. Use SERVLIM to specify one of the following limits:

- Maximum number of regular scans before NCP performs a special scan
- Minimum time elapsed between special scans.

For a subarea link connecting two NCPs, the service order table contains an entry for the link station that connects to the adjacent NCP. (See “Service Order Table” on page 24-4 for more information.) The regular scan of the table accommodates

## Subarea Links and Link Stations

normal transmission of PIUs between the access method or host processor application programs and the link station.

In a special scan of the service order table, NCP determines whether there are any outstanding commands from the access method to interrogate or alter the status of the link station. If so, NCP fulfills the first such command and then resumes regular scans of the table to perform normal servicing. If no stations require service during the special scan and no stations had required service during the preceding regular scan, a regular scan resumes after a delay of 2.2 seconds. If more than one status command is outstanding, only one is honored each time the special scan is made; the remaining status commands are fulfilled one at a time, in turn, during subsequent special scans of the table.

Upon completing a regular scan, NCP begins the special scan if one of the following is true:

- NCP found no active link station during the regular scan.
- The defined number of regular scans has been completed.
- A station completed an initial XID exchange but did not complete the activation procedure.

For example, type 2.1 nodes require an exchange of format 3 XIDs followed by a set normal response mode/unnumbered acknowledgement (SNRM/UA) sequence to complete activation. A special scan can be started after the XID3 exchange is complete even if an SNRM/UA sequence has not occurred.

TADDR specifies the physical address of the communication controller in which the secondary NCP is to reside. If you prefer, you can specify the subarea address instead of the physical address of the communication controller.

## GROUP

ACTIVTO on the GROUP definition statement defines values used when the NCP is in a secondary state. ACTIVTO specifies the time NCP waits for communication from the primary NCP before it deactivates the link. Code a value for ACTIVTO that is longer than the PAUSE value in the primary NCP.

MODE specifies whether the NCP is to operate in primary or secondary mode. In a point-to-point connection, MODE must be the same on the SDLCST and GROUP definition statements. If you are defining a multipoint subarea link, MODE=PRIMARY appears only on the GROUP definition statement for the primary NCP; all other nodes in the multipoint connection are coded with MODE=SECONDARY.

**Note:** You can code the REPLYTO and TEXTTO keywords on a GROUP definition statement that defines a primary NCP. Code only REPLYTO on a GROUP definition statement that defines a secondary NCP. Chapter 24 describes these keywords in more detail.

RNRLIMIT specifies the interval a given station has to reject data before NCP identifies the station as inoperative. A station is considered inoperative if it responds with a receive-not-ready (RNR) command to data or a poll sent by NCP during the interval defined.



**LINE**

CONFIG on the LINE definition statement specifies whether the subarea link is a switched or nonswitched link. A multipoint subarea link can be defined only as nonswitched.

DUPLEX specifies a duplex or half-duplex facility. A multipoint subarea link in a secondary state must be half-duplex.

SDLCST names each SDLCST definition statement that describes the primary or secondary NCP in a point-to-point subarea link. Code only the first suboperand when defining a primary subarea node; code only the second suboperand when defining a secondary subarea link.

TADDR specifies the hexadecimal address of a secondary link station attached to a subarea link. See *NCP, SSP, and EP Resource Definition Reference* for the specific instances when TADDR is required.

TRANSFR specifies how many buffers NCP is to receive during a data transfer. Code the same TRANSFR value for all links within the same transmission group; otherwise, you may experience link activation problems. See “Transmission Groups” on page 12-15 for more information.

**Note:** If you use the VTAM MODIFY LOAD command to add or replace a load module on the controller’s hard disk, the value of TRANSFR times the NCP buffer size (BFRS on the BUILD definition statement) must be at least 2048.

**PU**

ADDR on the PU definition statement identifies the polling address of the primary physical unit on a multipoint subarea link.

BLOCK on the PU definition statement specifies the maximum frame size and the maximum number of PIUs per frame. The value of BLOCK must not exceed the value of MAXFRAME for the physical line. See page 24-7 for more information on the BLOCK keyword.

MAXDATA limits the maximum amount of data the individual link station sends or receives in one data transfer. Code MAXDATA to minimize the coordination problems among different line types if the SDLC line is part of a mixed-media MLTG. The limit you specify includes one PIU or PIU segment and header information. Refer to the documentation for a specific device to determine the amount of data it can receive. See “MLTG Segment Size” on page 12-23 for more information about how to calculate the correct MAXDATA value for a line in a mixed-media MLTG.

MODULO specifies whether the link operates as a modulo-8 or a modulo-128 link for a switched subarea link. A modulo-8 link delivers up to seven information frames (I-frames) before a response is required. A modulo-128 link delivers up to 127 I-frames before a response is required. If you define a modulo-128 link, the link can operate as either modulo-8 or modulo-128, depending on the value coded for MAXOUT on the PU definition statement of the connecting NCP. See the description of MAXOUT on the SDLCST definition statement for more information and “Sample Definitions of Configurable Point-to-Point Subarea Links” on page 12-8 for examples of how a MODULO value is determined.

NPACOLL causes the NetView Performance Monitor (NPM) to collect performance statistics about the physical unit. When you define multipoint subarea links, NPM can collect performance data about type 4 or type 5 physical units.

## Subarea Links and Link Stations

PIUCHECK specifies whether a checksum validation should be performed on PIUs sent and received by this station. For the checksum validation support to be enabled, the adjacent link station must also have PIUCHECK=YES coded. For more information about the PIUCHECK subarea checksum support, see PIUCHECK keyword on the PU definition statement on page 24-9.

PUTYPE defines the type of physical unit associated with the connection. Code PUTYPE=4 to define the adjacent subarea node.

TGN specifies the number of the transmission group associated with the subarea link. See "Transmission Groups" on page 12-15 for additional information.

## Defining Configurable Point-to-Point Subarea Links

A point-to-point subarea link is considered to be configurable when a primary or secondary role is not assigned to a specific NCP in the system generation definition. Instead, roles are assigned dynamically by the system as connections are made between subareas. To define a configurable point-to-point subarea link, provide a definition for a primary NCP, a secondary NCP, and an interconnecting link between the NCPs. There must be two SDLCST definition statements: one for the primary NCP and one for the secondary NCP. There must be three GROUP definition statements: the first defines characteristics of the primary NCP, the second defines characteristics of the secondary NCP, and the third defines characteristics of the point-to-point subarea link connecting the two NCPs before XIDs are exchanged.

Follow the GROUP definition statement that defines the subarea link between the two NCPs with a LINE and a PU definition statement. These LINE and PU definition statements define the link connecting the two NCPs and the type of physical unit where the adjacent NCP resides. The SDLCST keyword on the LINE definition statement names the SDLCST definition statements for the primary and secondary NCPs.

The two GROUP definition statements that define the primary and secondary NCPs are called stand-alone definition statements. Stand-alone GROUP definition statements have no LINE or PU definition statements associated with them. Code the MODE keyword on the two stand-alone GROUP definition statements but not on the GROUP definition statement that defines the interconnecting link. The MODE value on the stand-alone GROUP definition statements must be consistent with the MODE value on the associated SDLCST definition statement.

### Sample Definitions of Configurable Point-to-Point Subarea Links

Figure 12-3 shows an example of a point-to-point subarea link with two NCPs.

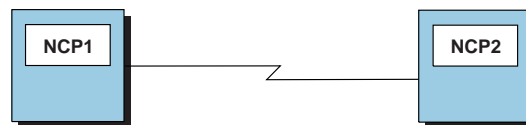

Figure 12-3. Point-to-Point Subarea Links

Figure 12-4 on page 12-9 shows how to define the point-to-point subarea link shown in Figure 12-3. The sample code enables the system to determine the role of the NCPs at either end of the point-to-point subarea link. The SDLCST definition

statements reference the names of the corresponding stand-alone GROUP definition statements that identify the primary NCP and the secondary NCP. The SDLCST keyword on the LINE definition statement contains the names of both the primary and secondary SDLCST definition statements.

The coding sample shows the relationship between the SDLCST group definition statement and the primary NCP, secondary NCP, and subarea link GROUP definition statements. A similar definition is required for the NCP at the other end of the point-to-point subarea link. See “Nonswitched Telecommunication Links” on page 5-1 for more information about how to code additional definition statements and keywords that define nonswitched telecommunication links.

APRI	SDLCST GROUP=A,MODE=PRI	Primary selection table entry (A)
*		
ASEC	SDLCST GROUP=B,MODE=SEC	Secondary selection table entry (B)
*		
A	GROUP MODE=PRI	Primary line group operation mode
*		
B	GROUP MODE=SEC	Secondary line group operation mode
*		
C	GROUP	SDLC group of subarea links
	LINE ADDRESS=(064,FULL),	Relative line number
	SDLCST=(APRI,ASEC)	Primary and secondary selection table entries
*		
	PU PUTYPE=4	NCP subarea node

Figure 12-4. Example: Defining Configurable Point-to-Point Subarea Links

Figure 12-5 shows how to define a configurable link with both NCPs specifying MODULO=128.

NCP1		NCP2	
BUILD	SUBAREA=4	BUILD	SUBAREA=2
	.		.
	.		.
SDLCST	MAXOUT=20, MODE=SECONDARY	SDLCST	MAXOUT=70, MODE=SECONDARY
*		*	
SDLCST	MAXOUT=10, MODE=PRIMARY	SDLCST	MAXOUT=50, MODE=PRIMARY
	.		.
	.		.
LINE	MODULO=128	LINE	MODULO=128
*		*	
PU	MAXOUT=10	PU	MAXOUT=50

Figure 12-5. Example: Defining Point-to-Point Subarea Links Using MODULO=128

During the contact procedure between the NCPs shown in Figure 12-5, NCP2 sends NCP1 its subarea number (SUBAREA=2) and the MAXOUT value from the PU definition statement (MAXOUT=50). NCP1 then sends its subarea number (SUBAREA=4) and the MAXOUT value from its PU definition statement (MAXOUT=10). Because the NCP1 subarea number is greater than the NCP2 subarea number, NCP1 becomes the primary NCP. NCP2 uses a MAXOUT value of 10 as the number of frames to send before an acknowledgment is required.

## Subarea Links and Link Stations

NCP2 then sends the MAXOUT value from its SDLCST definition statement with MODE=SECONDARY specified (MAXOUT=70), and the exchange is concluded. NCP1 uses a MAXOUT value of 70 as the number of frames to send before requiring an acknowledgment.

Figure 12-6 shows how to define a configurable link with each NCP specifying a different MODULO value. In Figure 12-6, NCP1 and NCP2 are adjacent NCPs connected by a subarea link. MODULO=128 is specified on the LINE definition statement for NCP1, and MODULO=8 is specified for NCP2.

NCP1		NCP2	
BUILD	SUBAREA=4	BUILD	SUBAREA=2
	.		.
	.		.
	.		.
SDLCST	MAXOUT=20, MODE=SECONDARY	SDLCST	MAXOUT=5, MODE=SECONDARY
*		*	
SDLCST	MAXOUT=10, MODE=PRIMARY	SDLCST	MAXOUT=2, MODE=PRIMARY
	.		.
	.		.
	.		.
LINE	MODULO=128	LINE	MODULO=8
*		*	
PU	MAXOUT=10	PU	MAXOUT=2

Figure 12-6. Example: Defining NCPs with Different MODULO Values

During the contact procedure between these NCPs, NCP2 sends NCP1 its subarea number (SUBAREA=2) and the MAXOUT value from the PU definition statement (MAXOUT=2). NCP1 then sends its subarea number (SUBAREA=4) and the MAXOUT value from the PU definition statement (MAXOUT=10). Because the NCP1 subarea number is greater than the NCP2 subarea number, NCP1 becomes the primary NCP. NCP2 operates only in modulo-8, so NCP2 cannot use 10 as the MAXOUT value. Instead, NCP2 uses a MAXOUT value of 7 (the default) as the number of frames to send to NCP1 before requiring an acknowledgment. NCP then sends the MAXOUT value from its SDLCST definition statement with MODE=SECONDARY specified (MAXOUT=5), and the exchange is concluded. NCP1 uses 5 as the number of frames to send before an acknowledgment is required.

## Defining Nonconfigurable Point-to-Point Subarea Links

A point-to-point subarea link is considered to be nonconfigurable when you use the system generation definition to define an NCP as primary or secondary. Use the MODE keyword on the SDLCST definition statement to assign the primary or secondary role to a particular NCP. Two GROUP definition statements are required: the first defines the NCP to be primary or secondary and the second defines characteristics of the point-to-point subarea link connecting the two NCPs.

LINE and PU definition statements are coded under the GROUP definition statement that defines the subarea link between the NCPs. These LINE and PU definition statements define the link connecting the two NCPs and the type of physical unit where the adjacent NCP resides. The SDLCST keyword on the LINE definition

statement names the SDLCST definition statement for either the primary or the secondary NCP.

Code the MODE keyword on the GROUP definition statement that defines NCP. The MODE value on this GROUP definition statement must be consistent with the MODE value on the associated SDLCST definition statement.

### Sample Definition of a Nonconfigurable Point-to-Point Subarea Link

Figure 12-7 shows how to define the point-to-point subarea link for the primary NCP shown in Figure 12-3 on page 12-8. Notice that this generation definition is very similar to the one shown in Figure 12-4 on page 12-9. The difference is that this sample definition contains only the primary SDLCST and GROUP definition statements. The NCP on the other end of the point-to-point subarea link is the secondary NCP.

APRI	SDLCST	GROUP=A,MODE=PRI	Primary selection table entry (A)
*			
A	GROUP	MODE=PRI	Primary line group operation mode
*			
C	GROUP		SDLC group of subarea links
	LINE	ADDRESS=(064,FULL),	Relative line number
		SDLCST=(APRI,)	Primary selection table entry
	PU	PUTYPE=4	NCP subarea node

Figure 12-7. Example: Defining Point-to-Point Subarea Links for a Primary NCP

Figure 12-8 shows how to define a point-to-point subarea link for the secondary NCP shown in Figure 12-3 on page 12-8.

ASEC	SDLCST	GROUP=B,MODE=SEC	Secondary selection table entry (B)
*			
B	GROUP	MODE=SEC	Secondary line group operation mode
*			
C	GROUP		SDLC group of subarea links
	LINE	ADDRESS=(064,FULL),	Relative line number
		SDLCST=(,ASEC)	Secondary selection table entry
	PU	PUTYPE=4	NCP subarea node

Figure 12-8. Example: Defining Point-to-Point Subarea Links for a Secondary NCP

## Defining Multipoint Subarea Links

Multipoint subarea links are defined by one GROUP definition statement with MODE defined as primary, a LINE definition statement that defines the interconnecting multipoint link, and multiple PU definition statements. Because a multipoint link enables many NCPs, hosts, and devices to connect to the single primary NCP, there must be as many PU definition statements as there are secondary physical units on the multipoint link. Code the ADDR keyword on each PU definition statement to define the polling address of each physical unit.

Secondary NCPs, hosts, or devices on a multipoint subarea link are defined with a GROUP, a LINE, and a PU definition statement. Code MODE=SECONDARY on the GROUP definition statement. Code TADDR on the LINE definition statement to specify the physical address of the secondary NCP, host, or device. Do not code

## Subarea Links and Link Stations

the following keywords on the LINE definition statement: CALINE, CHANLA, CHNLZ, CLINES, CORNUM, TAILING, LPDATS, and SERVLIM. Do not code ADDR or RETRIES on the PU definition statement.

**Note:** The following steps enable you to load or dump a communication controller in a secondary state on a multipoint subarea link:

1. Specify the secondary address of the controller to MOSS-E.
2. At the MOSS-E console, choose option G for G:GCS/IPL PORTS, and then choose option 2 for IPL PORTS.
3. On the next MOSS-E panel, select 9 for LINK COMMON OPTIONS.
4. Fill in your controller's secondary address on the SDLC CONTROLLER ADDRESS line. (A communication controller can have only one secondary address.)

### Sample Definition of Multipoint Subarea Links

Figure 12-9 shows an example of a multipoint subarea link configuration.

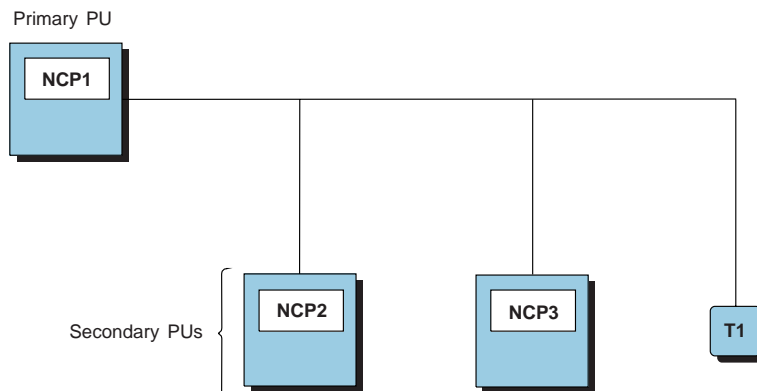

Figure 12-9. Multipoint Subarea Link Configuration

Figure 12-10 shows how to define the primary NCP shown in Figure 12-9. The multipoint subarea link definition contains a PU definition statement for each secondary physical unit on the multipoint link. The ADDR keywords specify the symbolic link station addresses of the secondary physical units. The other NCPs on the multipoint link are secondary NCPs.

C	GROUP	MODE=PRI	Primary NCP SDLC line group
*	LINE	ADDRESS=32	Relative line number
*	PU	ADDR=C1, PUTYPE=4	Polling address for this link NCP subarea node
*	PU	ADDR=C2, PUTYPE=4	Polling address for this link NCP subarea node
*	PU	ADDR=C3, PUTYPE=2	Polling address for this link Peripheral host node

Figure 12-10. Example: Defining a Multipoint Subarea Link for a Primary NCP

Figure 12-11 on page 12-13 shows how to define the secondary NCPs shown in Figure 12-9. TADDR on the LINE definition statement specifies the symbolic link station address for this NCP. This is the value coded on the ADDR keyword in the primary NCP generation definition.

C	GROUP	MODE=SEC	Secondary NCP SDLC line group
*	LINE	ADDRESS=31, TADDR=C1	Relative line number Symbolic link station address
*	PU	PUTYPE=4	NCP subarea node

Figure 12-11. Example: Defining a Multipoint Subarea Link for a Secondary NCP

## Defining Switched Subarea Links

Switched subarea support increases the flexibility of network communication by providing subarea-to-subarea communication over switched subarea links. Switched subarea links offer the following advantages over switched peripheral links:

- Switched subarea links negotiate their primary or secondary characteristics at XID exchange when connecting two NCPs. When the switched subarea link connects NCP and VTAM, whichever licensed program calls the other becomes the primary station. This designation overrides the values found in NCP and VTAM subareas.
- Switched subarea links can exist in networks that are defined at NCP system generation.
- Switched subarea links can belong to a transmission group.
- Switched subarea links can connect an NCP to either a type 4 physical unit or a type 5 physical unit.

In addition to these advantages, switched subarea support provides switched subarea links with activity timeout. Activity timeout breaks the subarea-to-subarea connection if no information is sent between the two stations for a predetermined time.

**Note:** You need to use an automatic calling unit for a switched subarea link. Manual dialing is not supported.

Code the following definition statements and keywords to provide NCP with information about how to define and manage switched subarea connections.

GROUP	ACTIVTO DIAL LINEAUT NETID PUTYPE
PU	BRKCON NETID

### GROUP

ACTIVTO on the GROUP definition statement specifies the length of time the secondary NCP is to wait for communication with the primary NCP before breaking the connection.

**Note:** For ISDN subarea lines, the PAUSE value does not affect ACTIVTO and does not need to be taken into account when determining a value. For other subarea lines, you should code a value for ACTIVTO that is longer than the PAUSE value in the primary NCP.

DIAL specifies whether the links in the group require switched connections. Code DIAL=YES when you define switched subarea links.

LINEAUT on the GROUP definition statement specifies automatic calling for a line group for which no physical address interface is defined. Code LINEAUT=YES for ISDN logical subarea lines.

NETID on the GROUP definition statement names the native network defined on the BUILD definition statement or the non-native network defined on the NETWORK definition statement. When you identify the native or non-native network, you associate the switched subarea group with that network.

PUTYPE defines the type of physical unit associated with the connection. Code PUTYPE=4 to define a switched subarea link.

### PU

BRKCON on the PU definition statement specifies the circumstances when a switched subarea connection is broken (an activity timeout). A timeout can occur if, during the time defined by ACTIVTO on the GROUP statement, no information frames were sent or received by the line. BRKCON can specify that an activity timeout starts when the two stations establish a connection or when NCP goes into ANS. BRKCON can also prevent a connection break on a switched line.

NETID on the PU definition statement specifies the name of the network containing the adjacent subarea node.

### Sample Definition of a Switched Subarea Link

Figure 12-12 shows an example of a switched subarea link.

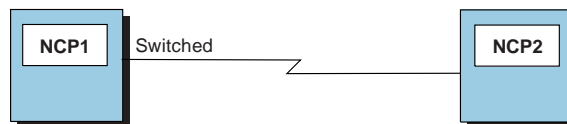

Figure 12-12. Switched Subarea Link Configuration

Figure 12-13 on page 12-15 shows how to define the switched subarea link shown in Figure 12-12. Notice that this generation definition is very similar to the one shown in Figure 12-4 on page 12-9. The difference is that DIAL=YES is coded on the subarea link GROUP definition statement, indicating a switched telecommunication link, and that PUTYPE=4 is coded on the GROUP definition statement, instead of on the PU definition statement.

**Note:** Additional definition statements and keywords that can be coded for switched telecommunication links are shown in “Switched Links” on page 5-4 and “SMMF for Switched SDLC Subarea Links” on page 5-13.



APRI	SDLCST	GROUP=A,MODE=PRI	Primary selection table entry (A)
*			
ASEC	SDLCST	GROUP=B,MODE=SEC	Secondary selection table entry (B)
*			
A	GROUP	MODE=PRI	Primary line group operation mode
*			
B	GROUP	MODE=SEC	Secondary line group operation mode
*			
C	GROUP	DIAL=YES, PUTYPE=4	SDLC group of switched subarea links
*			
	LINE	ADDRESS=(064,FULL),	Relative line number
		SDLCST=(APRI,ASEC)	Primary and secondary selection table entries
*			
	PU		

Figure 12-13. Example: Defining a Switched Subarea Link

---

## Token-Ring Subarea Links

You can define a Token-Ring connection between subarea nodes. You can assign one or more Token-Ring subarea links, along with one or more frame-relay or SDLC subarea links, to the same transmission group. For more information, see “Token-Ring Subarea Links” on page 6-27 and “Transmission Groups.”

---

## Frame-Relay Subarea Links

You can define frame-relay connections between subarea nodes. A frame-relay subarea link can join two adjacent nodes, or can pass through a frame-relay network. You can assign one or more frame-relay subarea links, along with one or more Token-Ring or SDLC subarea links, to the same transmission group. Frame-relay subarea links can provide greater efficiency than SDLC subarea links for connections among three or more NCPs. For more information, see “Transmission Groups,” “Defining Frame-Relay Logical Subarea Lines” on page 16-27, and “Converting SDLC Subarea Links to Frame Relay” on page 16-38.

---

## ISDN Subarea Links

You can define an ISDN connection between subarea nodes. The subarea link passes through an ISDN. For more information, see “Defining ISDN Logical Subarea Lines” on page 7-13.

---

## Transmission Groups

A transmission group is a group of one or more links between adjacent subarea nodes that appear as a single logical link for routing data. This section describes the following types of transmission groups:

- Single link transmission groups
- Multilink transmission groups (MLTGs)
- Parallel transmission groups.

### Single-Link Transmission Groups

A single-link transmission group contains a single channel link or SDLC, Token-Ring, frame-relay, or ISDN subarea link. Code the following definition statement and keyword to define a single-link transmission group.

PU	TGCONF
----	--------

TGCONF on the PU definition statement specifies whether a transmission group contains one or more logical subarea links. To improve NCP performance, code TGCONF=SINGLE when a transmission group contains a single Token-Ring, frame-relay, ISDN, or 3746 Model 900 SDLC line. Coding TGCONF=SINGLE for a transmission group with a single 3745-attached SDLC line does not affect NCP performance.

### Multilink Transmission Groups

A multilink transmission group (MLTG) is a group of two or more subarea connections. An MLTG permits larger bandwidth and continued transmission without loss of data if one or more links in the transmission group fail.

You can assign up to 255 SDLC, Token-Ring, frame-relay, and ISDN lines in any combination to the same MLTG. An MLTG that contains more than one line type is called a *mixed-media MLTG*.

**Note:** For an MLTG that contains at least one Token-Ring or frame-relay line, the NCP at the other end of the link must be NCP V6R2 or later. Otherwise, link activation will fail.

When a PIU is transmitted over an MLTG, NCP selects a subarea link for transmission of the PIU in order of line activation or in order of a user-defined priority. When a user-defined priority scheme is not defined, this selection process always begins with the first station in the chain of currently operative stations. When a line goes out of service and is later reactivated, it is queued after all other currently active lines in the MLTG.

If lines in an MLTG have different speeds, you can define a line selection priority that causes NCP to use high-speed lines first. When you prioritize line selection, and a line goes out of service, it is placed in the selection order according to its assigned priority when it is reactivated.

Defining MLTG links requires examination of the transmission characteristics of each link and any required common values. Be sure to assign the same transmission group number to all links in an MLTG and carefully determine a common transmission segment size. See "MLTG Segment Size" on page 12-23 for more information about how to define the segment size for individual links in the MLTG.

Code the following definition statements and keywords to provide NCP with information about how to select MLTG lines, identify resources, and improve NCP performance.

BUILD	MLTGORDR
PATH	DESTSA ER $n$
LINE	MLTGPRI
PU	PUTYPE TGCONF TGN

## BUILD

MLTGORDR is used to control link station selection. When a PIU is to be transmitted over an MLTG, the transmission group layer selects a station in the MLTG using the station selection mode specified on the MLTGORDR keyword on the BUILD definition statement. You can use the following station selection modes:

- Using MLTGORDR=FIFO

When station selection is first in, first out (MLTGORDR=FIFO), NCP searches for an available station in the MLTG in the order in which the stations were activated. The MLTG station-selection process always begins with the first station in the chain of operative stations.

- Using MLTGORDR=MLTGPRI

When station selection is by user-defined priority (MLTGORDR=MLTGPRI), NCP selects a station in the MLTG based on the value specified for the MLTGPRI keyword on the LINE or GROUP definition statement. The MLTG station-selection process uses either a round-robin or a combination fixed/round-robin search scheme to determine the next available station.

When transmission group stations have the same priority, the next available station is selected using a round-robin scheme. A round-robin search for an available station begins with the station in the MLTG following the last station over which a PIU was sent.

When transmission group stations have different priorities, a combination fixed/round-robin search can be in effect. This means that:

- The search for an available station always begins with one of the stations that has the highest value coded for MLTGPRI.
- If the MLTG includes more than one station with the highest value coded for MLTGPRI and if one of these stations is selected, the next search for an available station starts with one of these highest priority stations but not the one that was just selected.
- If a station is selected that does not have the highest MLTGPRI value, the next search for an available station begins with the same highest priority station that was used as the starting point for the current search.
- If a station is selected that does not have the highest MLTGPRI value and if the MLTG includes more stations with the same MLTGPRI value as that of the just-selected station, the MLTG is reordered so that the just-selected station becomes the last station of its priority.

## Transmission Groups

For example, if the MLTG consists of stations A and B with a priority level of 1, the round-robin search scheme is used to find an available station. However, if station C with a priority level of 2 is added to the MLTG, the combination fixed/round-robin is used. This means that station C will always be the first one checked for availability.

### PATH

DESTSA on the PATH definition statement specifies the destination subarea address.

ER $n$  identifies the explicit route number, the adjacent subarea number, and the transmission group number.

### LINE

MLTGPRI on the LINE definition statement specifies the priority value assigned to each line in the MLTG. Code MLTGPRI when you define a Token-Ring, frame-relay, ISDN, or SDLC line that is activated in an MLTG.

### PU

PUTYPE on the PU definition statement defines the type of physical unit associated with the connection. Code either PUTYPE=4 or PUTYPE=5 on the PU definition statement.

TGCONF specifies whether this subarea link station is in a multilink or single-link transmission group. TGCONF is valid only if you specify PUTYPE=4.

**Multilink Transmission Groups:** Code TGCONF=MULTI or omit TGCONF for all subarea link stations in a multilink transmission group.

**Single-Link Transmission Groups:** You do not need to code TGCONF for a single-link transmission group. However, coding TGCONF=SINGLE for a transmission group that contains a single SDLC, Token-Ring, frame-relay, or ISDN line can improve NCP performance for the transmission group.

**Standby Transmission Groups:** TGCONF=STANDBY designates whether a subarea station is to be used in Hot-Standby mode. TGCONF=STANDBY is not valid when TGCONF=SINGLE is coded.

TGCONF=(MULTI,STANDBY, $nn$ ) designates that a hot-standby subarea station transmit data for transmission group congestion relief if queued data reaches the value specified by  $nn$ .  $nn$  indicates the percent reached of the threshold specified by the *totthresh* suboperand of the ER $n$  keyword on the associated PATH statement. The *totthresh* suboperand defines the total number of bytes that can be queued for transmission to an MLTG before NCP takes control measures to slow down the TG traffic. If, for example, you code TGCONF=(MULTI,STANDBY,50), the standby station begins transmitting data when the queue reaches 50 % of the number of bytes specified by the *totthresh* value.

As the amount of data queued for transmission continues to increase, standby stations begin transmitting data as their  $nn$  value is reached. When the queue decreases, the stations return to standby mode successively. If the queue drops suddenly below the  $nn$  value of several stations, the stations still return to standby one at a time. For example, the transmission of a large PIU could drop the queue below several stations'  $nn$  values, the station with the highest value returns to standby mode. The next station returns to standby mode with the transmission of the next PIU. If the queue

suddenly empties, all operative standby stations return to standby mode simultaneously.

The coded congestion threshold is not taken into consideration if all normal (not standby) stations are inoperative. The standby stations transmit data regardless of threshold values. Also all standby stations become active regardless of whether some are already active for congestion relief. When a normal station becomes active again, all standby stations return to standby mode.

TGN identifies the number of the transmission group to which this link belongs. All links in an MLTG must share the same transmission group number. Failure to do so results in link activation problems.

You can choose a number from 1 to 255, or, if you code TGN=ANY, NCP or VTAM assigns the transmission group number passed in the XID from the adjacent subarea node. Transmission group exchanges (XIDs) between NCP and an adjacent subarea node are accepted if the transmission group numbers match, or if TGN=ANY, as shown in Table 12-1. You can code TGN=ANY for either NCP or an adjacent subarea node, but not for both. Do not code the same transmission group number for more than 255 physical and logical lines that can be concurrently activated.

Table 12-1. Format-2 XID and TGN Exchanges

Adjacent Node	NCP	XID Status
TGN=0 (ANY)	TGN=0 (ANY)	XID 2 is rejected and returned with TGN=0
TGN=0 (ANY)	TGN=x	XID 2 is accepted and returned with TGN=x
TGN=x	TGN=0 (ANY)	XID 2 is accepted and returned with TGN=x
TGN=x	TGN=x	XID 2 is accepted and returned with TGN=x
TGN=x	TGN=y	XID 2 is rejected and returned with TGN=y

**Note:** x and y are valid transmission group numbers from 1 to 255 inclusive.

### Sample Definition of an MLTG

Figure 12-14 shows an example of an MLTG.

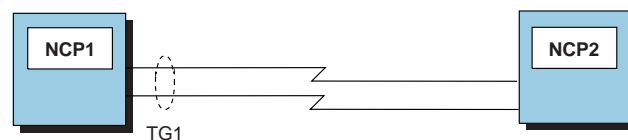

Figure 12-14. Multilink Transmission Group (MLTG)

Figure 12-15 on page 12-20 shows how to define the NCP1 MLTG shown in Figure 12-14. There are two SDLC links that can be used to route data through NCP2. They are both assigned to transmission group 1. Because MLTGORDR is not coded on the BUILD definition statement and MLTGPRI is not coded on the LINE definition statements, the lines are to be selected in the order of activation.

## Transmission Groups

GINN1	GROUP	LCNTL=SDLC	SDLC group of subarea links
*			
S01	LINE	ADDRESS=(001,FULL)	Relative line number
*			
P01	PU	PUTYPE=4, TGN=1	NCP subarea node Transmission group number is 1
*			
GINN4	GROUP	LCNTL=SDLC	SDLC group of subarea links
*			
S20	LINE	ADDRESS=(020,FULL)	Relative line number
*			
P20	PU	PUTYPE=4, TGN=1	NCP subarea node Transmission group number is 1 (same as P01)
*			

Figure 12-15. Example: Defining an MLTG

### Sample Definition of a Mixed-Media MLTG

Figure 12-16 shows an example of a mixed-media MLTG that supports Token-Ring and SDLC lines.

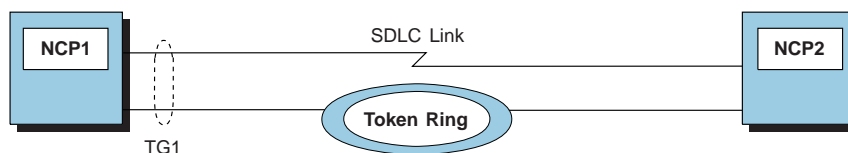

Figure 12-16. Mixed-Media MLTG

Figure 12-17 on page 12-21 shows how to define the NCP1 mixed-media MLTG shown in Figure 12-16. This MLTG includes an SDLC link and a 3746 Model 900 Token Ring connection. Both lines have TGCONF=MULTI coded on their session partner PU definition statements and are assigned to transmission group 1. The Token-Ring logical connection is assigned the highest MLTG priority. This means that if the Token-Ring logical line is available, it is selected for transmission.

**Note:** If you omit the TGCONF keyword, the default is TGCONF=MULTI.

```

A31NCP  BUILD MLTGORDR=MLTGPRI, MLTG links selected by MLTG priority *
.
*****
*** NCP SDLCST MACRO - SDLC SUBAREA COMMUNICATIONS CONTROLLER LINKS ***
*****
*
N31PRI  SDLCST MODE=PRI,GROUP=NTRINN
N31SEC  SDLCST MODE=SEC,GROUP=NTRSEC
*
S31PRI  SDLCST MODE=PRI,GROUP=A31GPRI
S31SEC  SDLCST MODE=SEC,GROUP=A31GSEC
.
.
*****
*      SUBAREA LINK:  SDLC FOR PRIMARY/SECONDARY STATION      *
*****
*
A31GPRI  GROUP  ACTIVTO=60.0,                                     *
          DIAL=NO,                                             *
          LNCTL=SDLC,                                          *
          MODE=PRI,                                           *
          REPLYTO=30,                                         *
          TYPE=NCP
*
A31GSEC  GROUP  ACTIVTO=60.0,                                     *
          DIAL=NO,                                             *
          LNCTL=SDLC,                                          *
          MODE=SEC,                                           *
          REPLYTO=30,                                         *
          TYPE=NCP
.
.

```

Figure 12-17 (Part 1 of 3). Coding Example: Defining a Mixed-Media MLTG

## Transmission Groups

```

*****
*SDLC SUBAREA LINES - 9.6 KBPS LINK - TGN=1 - LPDATS=LPDA2 TESTING *
*          CONNECT TO A04NCP LINE 001 OR LINE 033          *
*****
*
A31GINN1 GROUP ANS=CONT, *
                CLOCKNG=EXT, *
                DIAL=NO, *
                DUPLEX=FULL, *
                LNCTL=SDLC, *
                LPDATS=LPDA2, *
                MONLINK=NO, *
                NRZI=YES, *
                REPLYTO=3, *
                RETRIES=(30,1,3), *
                SDLCST=(S31PRI,S31SEC), *
                TGCONF=MULTI,      Part of MLTG *
                TGN=1 *
*
*****
* SUBAREA LINE ADDRESS=001 FULL DUPLEX *
*****
*
A31S01  LINE  ADDRESS=(001,FULL), *
                MLTGPRI=10          MLTG priority is 10 (2nd choice) *
*
A31P01  PU    LPDA=BLOCK, *
                MAXDATA=5000,      Maximum MLTG segment size is 5000 *
                PUTYPE=4 *
                . *
                . *
*
*****
*   TOKEN-RING SUBAREA LINK: SDLC FOR PRIMARY/SECONDARY STATION *
*****
*
NTRINN  GROUP ACTIVTO=420, *
                DIAL=NO, *
                LNCTL=SDLC, *
                MODE=PRI, *
                REPLYTO=3 *
*
NTRSEC  GROUP ACTIVTO=420, *
                DIAL=NO, *
                LNCTL=SDLC, *
                MODE=SEC *
                . *
                .

```

Figure 12-17 (Part 2 of 3). Coding Example: Defining a Mixed-Media MLTG



```

*****
*           3746 MODEL 900 PHYSICAL CONNECTIONS           *
*****
*
A3137CS  GROUP  ADAPTER=TIC3,                               *
                ANS=CONTINUE,                               *
                ECLTYPE=(PHYSICAL,ANY),                    *
                ISTATUS=ACTIVE,                            *
                TRSPEED=16,                                *
                USSTAB=AUSSTAB,                            *
                XID=NO                                     *
*
A31L2144  LINE  ADDRESS=(2144,FULL),                        *
                LOCADD=400000007041,                       *
                MAXTSL=3500,                                *
                PORTADD=10,                                 *
                TRSPEED=16,                                *
                XMONLNK=YES                                 *
*
A31P2144  PU    PUTYPE=1
                .
                .
*****
*  ALLOWS SUBAREA TRAFFIC BETWEEN THE CSS 2144 LINE AND THE 1088 LINE *
*  OF A04 NCP.                                                         *
*****
*
A31INNG3  GROUP  ANS=CONTINUE,                               *
                ECLTYPE=(LOGICAL,SUBAREA),                 *
                IPL=YES,                                   *
                ISTATUS=ACTIVE,                            *
                MAXOUT=3,                                  *
                MODETAB=AMODETAB,                          *
                MONLINK=YES,                               *
                PHYSRSC=A31P2144,                          *
                RETRIES=(3,2,1),                           *
                SDLCST=(,N31SEC),                           *
                TGCONF=MULTI,                               Part of a multilink MLTG *
                USSTAB=AUSSTAB                             *
*
A31LG2C   LINE  MLTGPRI=60,                                MLTG priority is 60 (1st choice) *
                TGN=1                                     Transmission group number is 1   *
*                                                         (same as SDLC PU A31P01 - defaulted)
A31PG2C   PU    ADDR=0440000000431,                         *
                MAXDATA=5000                               Maximum MLTG segment size is 5000 *
*                                                         (MAXDATA >= MAXTSL)
*                                                         (same as SDLC PU A31P01)

```

Figure 12-17 (Part 3 of 3). Coding Example: Defining a Mixed-Media MLTG

## MLTG Segment Size

NCP supports segmenting and blocking of PIUs when transmitting data over links in a mixed-media MLTG. Segmenting enables a link to transfer a PIU that is greater than the MLTG segment size. If a PIU is received that is larger than the segment size of the MLTG, it is broken up into PIU segments that are sent to the adjacent NCP and reassembled there. Blocking causes a link to transfer multiple PIUs in a single frame over an MLTG link. You can choose to block PIUs on some links in a mixed-media MLTG without defining blocking on all other links in the MLTG. See

## Transmission Groups

“Data Transfer” on page 24-6 for more information about how to define the BLOCK keyword.

Each link in a mixed-media MLTG has an individual segment size that may not be compatible with the segment sizes of other links in the MLTG. When you define different types of links, the value you code on the keywords TRANSFR, BFRS, MAXFRAME, MAXTSL, or RCVBUFC determines the segment size of all logical connections associated with that physical line.

You need to determine a common MLTG segment size that ensures uninterrupted transmission of data, regardless of the types of lines in the MLTG. By evaluating segment sizes for different links, you can identify the optimum segment size for all links transmitting data in the MLTG. Table 12-2 describes the line type, its associated keyword, and the method used by NCP to determine segment size for each type of line.

Table 12-2. How NCP Determines Segment Size

Line Protocol	Keywords that Affect Segment Size	How to Calculate Segment Size
SDLC	TRANSFR, BFRS	$(\text{TRANSFR} * \text{BFRS}) - 18$ bytes <b>1</b>
Token Ring	MAXTSL	MAXTSL value <b>2</b>
NTRI	RCVBUFC	RCVBUFC value-36 bytes <b>3</b>
Frame relay (BAN)	MAXFRAME	MAXFRAME value-50 bytes or LF-4 or MAXTSL-36 <b>4</b>
Frame relay	MAXFRAME	MAXFRAME value-16 bytes <b>4</b>
ISDN (BAN)	MAXFRAME	MAXFRAME value-50 bytes or LF-4 or MAXTSL-36 <b>5</b>
ISDN	MAXFRAME	MAXFRAME value-16 bytes <b>5</b>

**1** The PIU segment size for an SDLC link depends on the TRANSFR value and the BFRS value of the adjacent NCP, which are transferred when the XID exchange takes place. Multiply the TRANSFR value of the adjacent NCP times the BFRS value and subtract 18 bytes from the result.

**2** The PIU segment size for a 3746 Model 900 Token Ring or NTRI depends on the MAXTSL value.

**3** When you define a NTRI link, code RCVBUFC to limit the maximum segment size to be received. NCP uses the smaller of the MAXTSL value of this node or the RCVBUFC-36 value of the adjacent node as the segment size of the NTRI link.

**4** For a frame-relay boundary access node (BAN) format, the PIU segment size for a frame-relay link is the smaller of (1) this link's MAXFRAME-50 or LF-4, whichever is smaller, or (2) the adjacent node's LF-4 or MAXTSL-36, if the adjacent connection is to an NCP, whichever is smaller. LF is the largest frame indicator field in the routing information field in a frame-relay BAN frame. For all other frame-relay connections, the PIU segment size for a frame-relay link is the smaller of (1) this link's MAXFRAME-16 or (2) the adjacent node's MAXFRAME-16.

**5** For an ISDN connection with the frame-relay boundary access node (BAN) format, the PIU segment size for an ISDN link is the smaller of (1) this link's MAXFRAME-50 or LF-4, whichever is smaller, or (2) the adjacent node's LF-4 or

MAXTSL-36, if the adjacent connection is to an NCP, whichever is smaller. LF is the largest frame indicator field in the routing information field in a frame-relay BAN frame. For all other ISDN connections, the PIU segment size for an ISDN link is the smaller of (1) this link's MAXFRAME-16 or (2) the adjacent node's MAXFRAME-16.

Figure 12-18 shows how keyword values affect segment size.

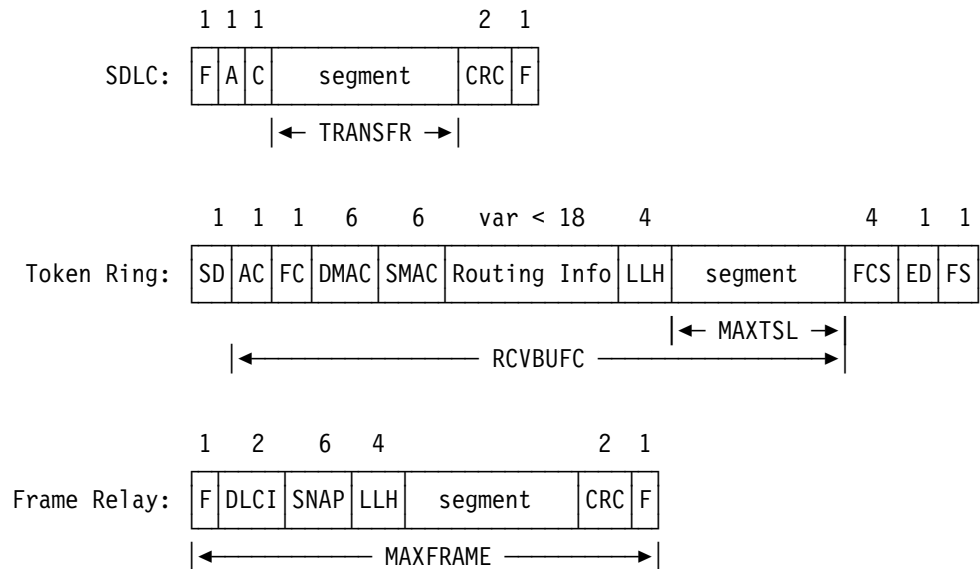

Figure 12-18. PIU Segment Size

Code MAXDATA on the PU definition statement for a logical connection to define a value that is equal to the smallest segment size used by any link in the MLTG, thereby eliminating transmission problems due to incompatible segment sizes for different links in the MLTG. For a leased line, code MAXDATA on the PU definition statement in the NCP generation definition and for a switched line, code MAXDATA on the PU definition statement in the VTAM switched major node definition. Follow these steps to arrive at a common MLTG segment size:

1. Define each link in the MLTG using optimum performance values without considering a common MLTG segment size.
2. Calculate the segment size for each link in the MLTG using Table 12-2 on page 12-24 and Figure 12-18.
3. Code MAXDATA on each PU definition statement that defines a link station in the MLTG. The MAXDATA value should be the smallest segment size used by any link in the MLTG.

If you do not define a common MLTG segment size using MAXDATA, the order of link activation determines the segment size for the transmission group. The segment size of the first link to be activated becomes the transmission group segment size used by all other links in the group, even if the defined segment size of other links is greater. If a link has a smaller defined segment size than the transmission group segment size, it will fail when an attempt is made to activate the link. However, if the transmission group is inactive with no PIUs outstanding, the link can be successfully activated and the segment size of the transmission group is reduced to the segment size of the activated link.

## Transmission Groups

When you code the definition statements and keywords described in “Multilink Transmission Groups” on page 12-16, add the following definition statements and keywords to provide NCP with information about individual links and their segment size limitations.

BUILD	BFRS TRANSFR
LINE	MAXFRAME MAXTSL RCVBUFC
PU	MAXDATA

### BUILD

BFRS on the BUILD definition statement defines the size of the buffers in the NCP buffer pool. Buffers from this pool contain PIU messages from access methods in channel-attached host processors, other NCPs, and link-attached devices. Code a BFRS value that is a multiple of four to provide fullword alignment.

TRANSFR specifies how many buffers NCP can receive during a data transfer.

### LINE

MAXFRAME on the LINE definition statement specifies the maximum size frame to be transmitted over a physical frame-relay line.

MAXTSL specifies the maximum amount of data, including the transmission header, the request header, and the response unit, to be transmitted over a physical line in a single Token-Ring frame.

RCVBUFC defines the NCP buffer capacity for receiving data over a NTRI physical line connection during one data transfer. The RCVBUFC value must be greater than or equal to the maximum amount of data (in bytes) that a NTRI physical line can receive in one data transfer operation.

### PU

MAXDATA on the logical PU definition statement limits the amount of data an individual link station sends or receives in one data transfer. The limit you specify includes one PIU or PIU segment and header information. Calculate the segment size each link in the MLTG is capable of transmitting and select the smallest as the MAXDATA value. When the MAXDATA value is the smallest segment size of any link in the MLTG, it eliminates the coordination problems among different line types in the MLTG.

## Parallel Transmission Groups

Parallel transmission groups are multiple transmission groups that exist between NCP and a type 5 physical unit node. Parallel transmission groups within a network allow VTAM and NCP to communicate over as many as 16 channel links, each of which is a separate transmission group. This can be any combination of type 6, type 7, and ESCON channel links. You can assign a specific transmission group number, or you can let the adjacent link station (NCP or VTAM) determine the transmission group number during the XID exchange.

Code the following definition statements and keywords to provide NCP with information about how to define and manage parallel transmission groups.

PATH	DESTSA ER $n$
GROUP	LNCTL
PU	PUTYPE TGN

**PATH**

DESTSA on the PATH definition statement specifies the destination subarea address.

ER $n$  identifies the explicit route number, the adjacent subarea number, and the transmission group number.

**GROUP**

LNCTL on the GROUP definition statement identifies the type of line control used for all lines defined in the group. Code LNCTL=CA for parallel transmission groups.

**PU**

PUTYPE on the PU definition statement defines the type of physical unit associated with the connection. Code PUTYPE=5 when you define a parallel transmission group.

TGN identifies the number of the transmission group to which this link belongs. You can choose a number from 1 to 255, or, if you code TGN=ANY, NCP or VTAM assigns the transmission group number passed in the XID from the adjacent subarea node.

**Sample Definition of a Parallel Transmission Group**

Figure 12-19 shows an example of a parallel transmission group configuration.

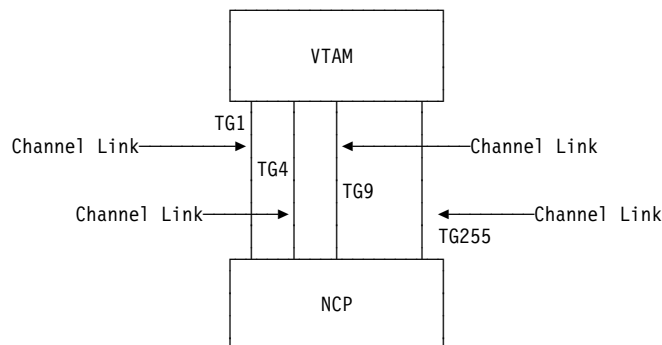

Figure 12-19. Parallel Transmission Groups

Figure 12-20 on page 12-28 shows how to code the parallel transmission group shown in Figure 12-19. Notice that four explicit routes are defined to subarea 81 through transmission groups 1, 4, 9, and 255.

## Power-Off Feature in a Link-Attached Controller

	PATH	DESTSA=81, ER0=(81,1), ER1=(81,4), ER2=(81,9), ER3=(81,255)	Paths to destination subarea 81 via transmission group 1 via transmission group 4 via transmission group 9 via transmission group 255
*			
CAG1	GROUP	LCNTL=CA, CA=TYPE7	Define channel adapters Channel adapter type 7
*			
CAP1 P01A	LINE PU	ADDRESS=P1 PUTYPE=5, TGN=1	Physical position 1 Subarea host node Transmission group number is 1
*			
CAP3 P03A	LINE PU	ADDRESS=P3 PUTYPE=5, TGN=4	Physical position 3 Subarea host node Transmission group number is 4
*			
CAP5 P05A	LINE PU	ADDRESS=P5 PUTYPE=5, TGN=9	Physical position 5 Subarea host node Transmission group number is 9
*			
CAP7 P07A	LINE PU	ADDRESS=P7 PUTYPE=5, TGN=255	Physical position 7 Subarea host node Transmission group number is 255

Figure 12-20. Example: Defining Parallel Transmission Groups

---

## Power-Off Feature in a Link-Attached Controller

The power-off feature enables the access method to instruct an NCP to issue a power-off command to another link-attached NCP. Code the following definition statement and keyword to activate the NCP power-off feature.

BUILD	PWROFF
-------	--------

PWROFF specifies whether NCP turns off an adjacent link-attached controller's power upon command from a channel-attached access method. Code PWROFF if your NCP is channel-attached.

---

### Remote Loading and Activation of a Link-Attached NCP

You can use an SDLC or X.21 subarea link to load an NCP load module into a remote communication controller containing an active NCP, and then activate the new NCP through SMMF. There are two ways to do this:

- You can use the IBM 3745 Controller Load and Dump Program (CLDP) to perform a remote load over a TSS or HPTSS SDLC subarea link or a TSS or HPTSS nonswitched X.21 subarea link.
- You can use NCP to perform a remote load over a Token-Ring, frame-relay, X.25 or switched X.21 subarea link attached to an IBM 3745. You can also use NCP to perform a remote load over an SDLC, Token-Ring, frame-relay, ISDN, X.25 NPSI, X.25 ODLC, or nonswitched X.21 SDLC subarea link attached to a 3746 Model 900. To do this, the active NCP in the remote controller must include one of these subarea links defined with:
  - XMONLNK=YES on the PU definition statement for the physical line  
For ISDN, XMONLNK=YES must be coded on the PU definition statement for the ISDN B-channel as well as the physical line.
  - IPL=YES and MONLINK=YES on the LINE definition statement for the logical subarea line.

For a complete description of the process for remote loading and activation using CLDP or NCP, refer to *NCP, SSP, and EP Generation and Loading Guide*.

---

### Defining Casual Connection Links between Subareas

The casual connection function enables NCP to communicate with adjacent NCPs as type 2.1 nodes rather than as subarea nodes. Composite type 2.1 nodes can communicate through the casual connection function by having cross-defined independent logical units that do not need to exchange explicit route, virtual route, or path information. Session information is defined by the BIND, which is sent by a primary logical unit to a secondary logical unit. Casual connection also supports attachment of composite type 2.1 nodes over switched SDLC links, Token-Ring links, ISDN links, X.25 NPSI, X.25 ODLC, frame-relay links, and nonswitched SDLC connections, including multipoint lines. See “Defining Switched Subarea Links” on page 12-13 and “Token-Ring Subarea Links” on page 6-27 for more information about subarea links. Figure 12-21 on page 12-30 illustrates a casual connection.

## Defining Casual Connection Links between Subareas

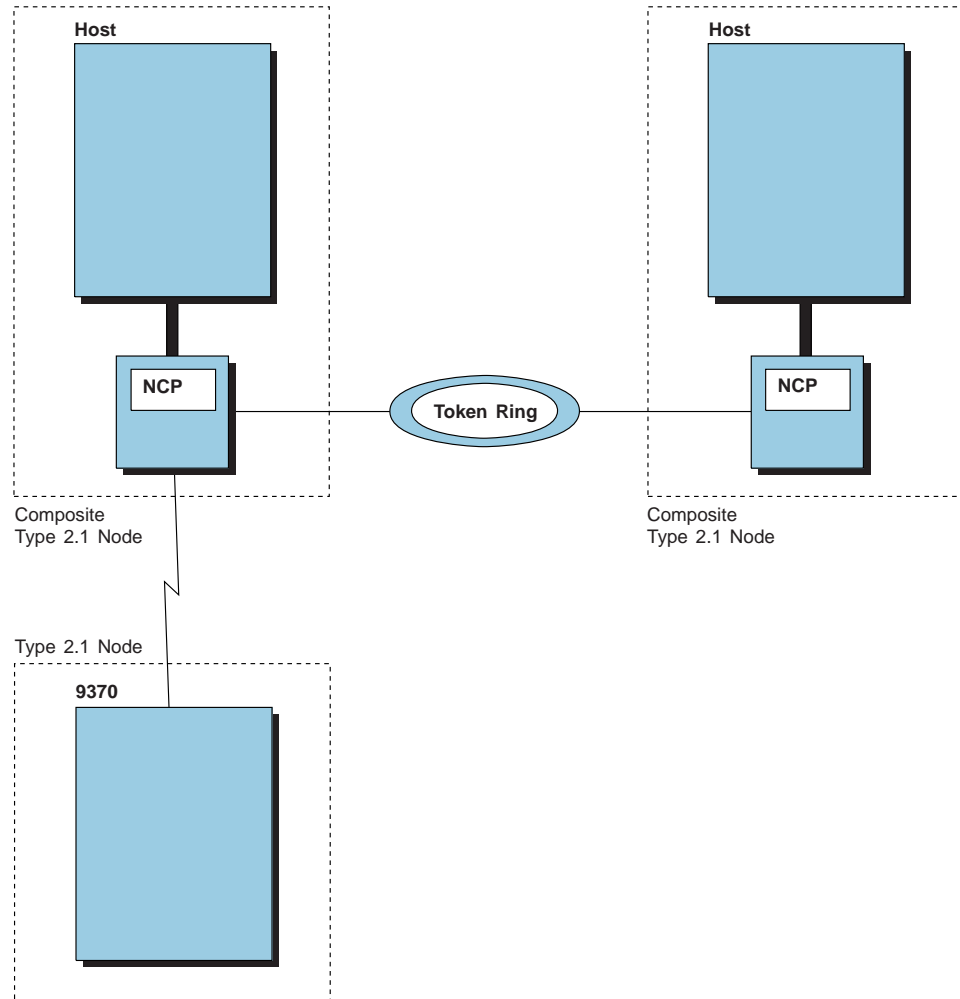

Figure 12-21. Casual Connection Links Between Subareas

Because composite type 2.1 nodes that are in different networks can communicate by using the nonnative network attachment and casual connection features, they do not need to have matching network identifiers.

Addressing another node as a type 2.1 node avoids much of the overhead involved in connecting subareas. Casual connection provides simpler generation definitions to specify this connection between subarea nodes because PATH definition statements are not needed. Since you need to code fewer PATH definition statements, making configuration changes is easier. However, because casual connection does not support multilink transmission groups, it is more appropriate for composite type 2.1 nodes that require occasional, rather than permanent, connections.



## Defining Casual Connection Links between Subareas

The following restrictions apply to casual connection:

- The link station role must be predefined as primary or secondary on non-switched peripheral lines (NCP performs role negotiation on nonswitched subarea lines).
- LPDA is not supported on a line that is defined as secondary.
- A line that is defined as secondary can have only one physical unit.
- A physical unit that is defined as the secondary link station cannot be added, moved, or deleted using dynamic reconfiguration.

Code the following definition statements and keywords to provide NCP with information about how to manage the resources, performance considerations, and error recovery.

GROUP	ACTIVTO DIAL MODE
LINE	DUPLEX HDXSP LPDATS MAXPU NEWSYNC RETRIES SRETRY TADDR TAILING
SERVICE	MAXLIST ORDER
PU	ADDR IRETRY PASSLIM PUDR PUTYPE ROLE XID

### GROUP

ACTIVTO on the GROUP definition statement specifies the amount of time that the secondary NCP is to wait for communication from the primary NCP. Code ACTIVTO when you define switched SDLC lines.

DIAL specifies whether the links in the group require switched connections.

MODE specifies whether NCP is the primary or secondary link station on the line. When defining a nonswitched casual connection between two NCPs, you must code MODE=SEC in the secondary NCP. Do not code the MODE keyword in the primary NCP. Code MODE when you define nonswitched SDLC lines. When

## Defining Casual Connection Links between Subareas

defining switched SDLC lines, Token-Ring lines, ISDN logical peripheral lines, or frame-relay logical peripheral lines, do not code MODE in either NCP; link station roles are negotiated on these connections.

### LINE

DUPLEX on the LINE definition statement controls the request-to-send (RTS) signal on the line. Code DUPLEX=HALF when defining the secondary NCP in a casual connection.

HDXSP specifies whether sending data to a device has priority over polling the device. Secondary link stations do not poll, so code HDXSP=NO when defining the secondary NCP in a casual connection. Code HDXSP for SDLC lines.

LPDATS on the LINE definition statement specifies the LPDA mode. Code LPDATS=NO (or let LPDATS default to NO) when defining the secondary NCP in a casual connection on an SDLC line.

MAXPU defines the maximum number of physical devices you can attach to the link. Code MAXPU=1 when defining the secondary NCP in a casual connection.

NEWSYNC determines whether the communication controller supplies the new-sync signal to the modem attached to the controller for the telecommunication link. Code NEWSYNC=NO when defining the secondary NCP in a casual connection on an SDLC line.

RETRIES specifies how many attempts NCP is to make to recover from errors that occur during transmission over a link. Code only the *m* suboperand of RETRIES when defining the secondary NCP in a casual connection. Suboperands *t* and *n* are not valid.

SRETRY specifies how many retries a secondary physical unit can attempt. This keyword is valid only for switched SDLC lines.

TADDR specifies the physical address of the secondary NCP on an SDLC line. It is required if the line is a nonswitched SDLC line, but it is optional if the line is a switched SDLC line. The value coded on TADDR in the secondary NCP should be the same as the value coded on the ADDR keyword of the PU statement in the primary NCP.

TAILING specifies whether a second-level LPDA circuit (second line segment) is attached to the line. If you specify TAILING=YES, do not use X'FD' or X'FF' for the station address of an SDLC device.

### SERVICE

**Note:** You can omit the SERVICE definition statement when defining the secondary NCP in a casual connection.

MAXLIST on the SERVICE definition statement defines the maximum number of entries needed in the service order table. If you choose to code the SERVICE definition statement for the secondary NCP in a casual connection, code MAXLIST=1.

ORDER enables you to specify the sequence of the entries in the service order table for nonswitched telecommunication links and whether you want more than one poll for each cycle. If you choose to code the SERVICE definition statement

### PU

for the secondary NCP in a casual connection, code only a single entry on the ORDER keyword.

ADDR on the PU definition statement specifies the hexadecimal representation of the 8-bit address of the physical unit. For a physical unit on an SDLC line, do not code ADDR when defining the secondary NCP in a casual connection; the address is coded on the TADDR keyword of the LINE statement.

IRETRY on the PU definition statement specifies whether NCP repolls a given secondary station before advancing to the next station in the service order table. Code IRETRY=NO when defining the secondary NCP in a casual connection.

PASSLIM defines the number of consecutive PIUs to be sent to a type 2.1 physical unit. The default is PASSLIM=254 when defining the secondary NCP in a casual connection.

PUDR specifies whether you can later delete the device from the link. Code PUDR=NO when defining the secondary NCP in a casual connection.

PUTYPE defines the type of physical unit associated with the connection. Code PUTYPE=2 to define the adjacent node.

ROLE specifies which operating mode the physical unit assumes at CONTACT time if format-3 XIDs are exchanged during the connect sequence on a switched SDLC line. When defining a casual connection between two NCPs on a switched SDLC line, code ROLE=NEG (or let ROLE default to NEG) in both NCPs. This allows the NCPs to negotiate the link station roles. If you prefer to predefine one of the NCPs to be primary, code ROLE=PRI in that NCP, and code ROLE=NEG (or let ROLE default to NEG) in the other NCP.

XID specifies whether the type 2.1 physical unit can receive and respond to an XID while in normal disconnected mode (NDM). Code XID=YES when defining the secondary NCP in a casual connection.

### Sample Definition of Casual Connection

Figure 12-22 on page 12-34 shows an example of a casual connection between two subareas that appear to be type 2.1 nodes.

## Defining Casual Connection Links between Subareas

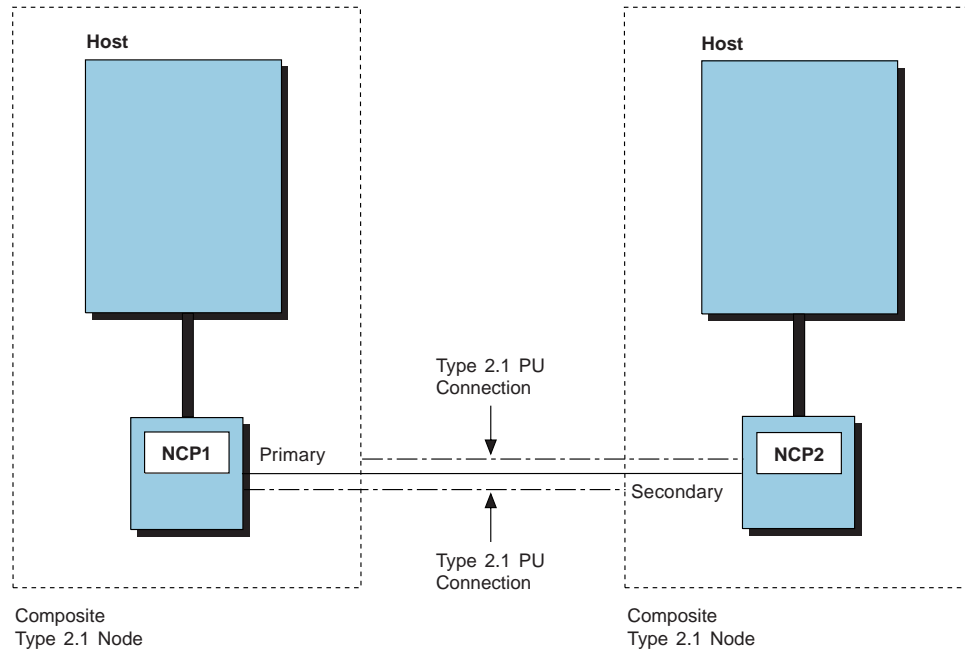

Figure 12-22. Casual Connection between Composite Type 2.1 Nodes

Figure 12-23 and Figure 12-24 on page 12-35 show how to define a casual connection between the subareas shown in Figure 12-22. Figure 12-23 shows how to define the primary NCP shown in Figure 12-22. Notice that instead of coding PUTYPE=4, you code PUTYPE=2 and XID=YES, indicating a type 2.1 node.

CCNP	GROUP		Primary NCP SDLC line group
*			
CCN16	LINE	ADDRESS=(016,FULL)	Relative line number
*			
PU16	PU	ADDR=C1, PUTYPE=2, XID=YES	Polling address for this link PU type 2 connection Type 2.1 connection

Figure 12-23. Example: Defining the Primary NCP in a Casual Connection

Figure 12-24 shows how to define the secondary NCP shown in Figure 12-22. PUTYPE=2 and XID=YES are coded to define a type 2.1 node.

## Defining Casual Connection Links between Subareas

```
CCNG2  GROUP MODE=SEC           Secondary NCP SDLC line group
*
CCN16  LINE ADDRESS=(016,FULL), Relative line number
        DUPLEX=HALF,
        HDXSP=NO,
        LPDATS=NO,
        MAXPU=1,
        NEWSYNC=NO,
        RETRIES=(5),           Maximum of 5 retry attempts
        TADDR=C1              Symbolic link station address
*
PU16   PU  IRETRY=NO,
        PASSLIM=12,          Up to 12 PIU segments sent at a time
        PUDR=NO,
        PUTYPE=2,           PU type 2 connection
        XID=YES            Type 2.1 connection
```

Figure 12-24. Example: Defining the Secondary NCP in a Casual Connection



---

## Chapter 13. Customized Functions

You can include special device support and functions in your NCP through IBM special products such as Network Terminal Option (NTO), Network Routing Facility (NRF), and X.25 NCP Packet Switching Interface (NPSI), or user-written code. This chapter describes the definition statements and keywords you need to customize NCP. Use *NCP and SSP Customization Guide* and *NCP and SSP Customization Reference* to provide information about the support and functions of IBM special products and how to write and include user-written code in your NCP. See the installation manuals for NTO, NRF, and NPSI for detailed information about how to define these programs and how to modify NCP to include them.

---

### User Line Control

You can connect non-SNA devices and implement customized line control protocols if you define line control routines to NCP. When you define your own line control protocol to NCP, you create routines that replace normal NCP processing. Customized line control requires the following minimum functions:

- An SNA command handler
- A level 2 interrupt handler
- Level 2 and level 3 routers
- A link scheduler, which includes:
  - XIO handlers
  - Link-scheduling routines
  - Error handlers
  - Command enders
- Timer routines.

Code the following definition statements and keywords to provide NCP with information about control block compatibility, level 2 and level 3 routers, link schedulers, and timer routines.

GROUP	COMPACB COMPOWN COMPSWP COMPTAD LEVEL2 LEVEL3 LEVEL5 LINEADD LINEAUT TIMER USERID XIO
LINE	AUTUACB UACB

NCP provides user adapter control blocks (UACBs) for line groups governed by user-defined line control. UACBs provide an interface between your line and NCP; therefore, UACBs must have a format similar to the control blocks used by NCP. A control block is compatible when certain fields in the UACB are at the same offsets as those in an NCP adapter control block (ACB). Code COMPACB, COMPOWN, COMPSWP, and COMPTAD to ensure the required compatibility.

### GROUP

COMPACB on the GROUP definition statement specifies whether a UACB for a line defined in this line group is compatible in format to an NCP ACB.

COMPOWN specifies that the control blocks for the lines in this group are compatible in format with the fallback, switchback, and LA disconnect functions.

COMPSWP specifies whether the user-defined control block structure is compatible with the NCP control block structure for port swapping of the lines in this line group. Code COMPTAD=YES to specify a compatible control block structure that allows initialization, updating of the configuration data set, and bus switching.

LEVEL2 identifies the entry points of the user-written or NTRI code for level 2 scanner interrupts. If you code LEVEL2, also code LEVEL3 on the GROUP definition statement and SRCLO on the GENEND definition statement. Level 2, level 3, and level 5 routers receive control from NCP routers when an interrupt is generated for a customized line.

LEVEL3 identifies the entry points of the user-written or NTRI code for level 3 interrupts.

LEVEL5 specifies whether level 5 code is provided by NCP or is user-written. Do not code LEVEL5 unless you code the LEVEL2 and LEVEL3 keywords. If level 5 code is user-written, code only the GROUP, LINE, and SERVICE definition statements for this group.

LINEADD specifies that a telecommunication line group has no physical address interface defined.

LINEAUT specifies auto-call for the line group. Code LINEAUT only if the telecommunication line group is made up of switched links and has no physical address interface defined.

TIMER specifies the four entry points for user-written or NTRI timer routines. These routines are the timer error service routine, the RAS service routine, the shoulder-tap routine, and the lagging shoulder-tap routine. NCP timer routines provide timeout services for communication lines. If you define a customized line control protocol, user-defined timeout routines must be defined to NCP.

USERID specifies the names assigned to user-defined control blocks associated with the line group, the entry label of the block dump table, and the type of RECMS processing to be performed for this line group.

XIO names the four entry points in the following user-written service routines:

- The execute-I/O-line-service routine
- The execute-I/O-set-mode-service routine
- The execute-I/O-immediate-service routine
- The execute-I/O-link-service routine.



The XIO handler is the interface from NCP peripheral and physical services in level 5 to the user-written link scheduler.

**LINE**

AUTUACB on the LINE definition statement specifies the name of the user adapter control block associated with the automatic calling unit (ACU) defined by AUTO on the LINE definition statement. See page 5-6 for more information about the AUTO keyword.

UACB specifies the names of the user adapter control blocks associated with the line.

**Programmed Resources**

Programmed resources are physical and logical units that reside in the controller. They provide unique functions that are external to NCP, such as specialized data collection or customized SSCP functions.

Code the following definition statements and keywords to provide NCP with information that identifies the physical and logical resource, associated control blocks, and function vector tables.

GROUP	VIRTUAL
LINE	LINECB LINEFVT
PU	PUCB PUFVT PUNTFY
LU	LUCB LUFVT LUNTFY NUMSESS

**GROUP**

VIRTUAL on the GROUP definition statement specifies whether the line group supports programmed resources.

**LINE**

LINECB on the LINE definition statement specifies the name of a user-defined control block associated with the virtual line.

LINEFVT names the function vector table associated with the virtual line.

**PU**

PUCB on the PU definition statement specifies the name of a user-defined control block associated with the virtual physical unit.

PUFVT specifies the name of the function vector table associated with the virtual physical unit.

## User Channel Control Code

### LU

PUNTFY specifies whether the notify byte is included in user-written code for the virtual physical unit and whether control is passed to the user-written notify task.

LUCB on the LU definition statement specifies the names of user-defined control blocks associated with the virtual logical unit.

LUFVT names the function vector tables associated with the virtual logical unit.

LUNTFY specifies whether the notify byte is included in user-written control blocks for the virtual logical unit and whether control is passed to a user-written notify task.

NUMSESS specifies the number of half-session control blocks (HSCBs) associated with the virtual logical unit.

---

## Network Addressable Units

A network addressable unit (NAU) is a programmed resource that is internal to NCP and provides SSCP functions. Code the following definition statements and keywords to provide NCP with information about function vector tables, control blocks, and how the NAU is to function.

NCPNAU	NAUCB
	NAUFVT
	NOTIFY
	NUMSESS
	TYPE

NAUCB on the NCPNAU definition statement names the user-defined control blocks associated with the NAU.

NAUFVT names the function vector tables associated with the NAU.

NOTIFY specifies the use of the notify byte in user-written control blocks for the NAU and whether control is passed to a user-written notify task.

NUMSESS specifies the number of HSCBs associated with the NAU.

TYPE specifies whether the NAU functions as a system services control point (SSCP) or a logical unit.

---

## User Channel Control Code

User channel control code is user-written line control for emulation subchannels. Code the following definition statements and keywords to provide NCP with information about function vector tables, control blocks, and how the emulation subchannel is to function.

BUILD	UCHAN
GROUP	CAEXIT CHANLNK
LINE	ADDRESS
LU	UCCB

**BUILD**

UCHAN on the BUILD definition statement specifies whether user-written channel control code is provided for any channel adapter.

**GROUP**

CAEXIT on the GROUP definition statement specifies the entry points of the following user-written channel adapter service routines:

- Level 1 error recovery procedure routine
- System reset routine
- Timer interrupt routine
- The routine to handle program request interrupts, suppress-out monitor requests, and permission-to-process stacked requests.

CHANLNK specifies whether this line group defines a communication link and emulator subchannel combination for which user-written routines handle emulator channel operations.

**LINE**

ADDRESS on the LINE definition statement defines the channel adapter logical addresses.

**LU**

UCCB on the LU definition statement specifies the name of the user channel control block associated with the logical unit when the channel operation is handled by user-written code.

---

**Entry Points and Library Member Names**

When you customize NCP, the user-written routines must be link-edited into the NCP load module and entry points defined for each routine. Code the following definition statements and keywords to provide NCP with information about the entry points and library names of modules to be assembled in the system generation definition.

GENEND	INIT SRCHI SRCLO TMRTICK UACCTNG UGLOBAL
--------	---

INIT on the GENEND definition statement specifies the symbolic entry point of user-written, NTRI, or 3745 frame-relay initialization routines. These routines must

## Linkage Editor Statements

be object modules cataloged in the appropriate MVS, VM, or VSE object library. If you code INIT, also code INCINIT, INCHI, or INCLO on the GENEND definition statement. If you specify entry points for NTRI routines, you do not need to code INCINIT, INCHI, INCLO, or SRCLO on the GENEND statement.

SRCHI and SRCLO identify the cataloged names of the source code modules containing the user-defined control blocks and tables that must be assembled with NCP control blocks and tables. The source code must be in definition statement form using assembler instructions. Source code modules identified by the SRCHI keyword reside above the NCP code in controller storage. This can place them above the 4MB boundary. Source code modules identified by the SRCLO keyword reside below the 4MB boundary.

TMRTICK specifies the symbolic entry point of a user-written, NTRI, or 3745 frame-relay timer-tick service routine. This routine must be an object module cataloged in the appropriate object library, depending on which operating system you run.

UACCTNG specifies the symbolic entry point of one or more user-written accounting notification routines. You can code user-written accounting routines only if NCP is collecting session data, that is, only if you code SESSACC=YES on the BUILD definition statement.

UGLOBAL specifies the symbolic entry point of user-written, NTRI, or 3745 frame-relay routines working as global routers to other functions that (1) have no existing entry points and (2) are controlled by IBM special products or user-written code. The parameter and status area of such a product or code contains information for the router about the function controlled and other status information.

---

## Library Members That Contain Linkage Editor Statements

You can specify library members that contain linkage editor INCLUDE or ORDER statements when you link-edit user-written routines into the NCP load module. Code the following definition statements and keywords to provide NCP with information about the names of modules containing those statements to be included or ordered.

**Note:** If you include special device support and functions in NCP through certain IBM products or user-written code that use the NDF standard attachment facility, some of these keywords are not applicable. See the documentation for the specific IBM products you use or *NCP and SSP Customization Guide* and *NCP and SSP Customization Reference* for more information.

GENEND	INCHI
	INCINIT
	INCLO
	INCL2HI
	INCL2LO
	KEY0INC
	KEY0ORD
	ORDHI
	ORDINIT
	ORDLO
	ORDL2HI
	ORDL2LO

INCHI and INCLO on the GENEND definition statement specify the library members that contain linkage-editor INCLUDE statements for object modules that are *not* level 2 or level 3 code. These modules execute with a storage protect key of 1. If you code INCHI, also code ORDHI. The generation procedure assumes the block-handling routine linkage-editor control statements are included in the members defined for INCHI and ORDHI.

If you code INCLO, also code ORDLO. Object code specified with the INCHI and ORDHI keywords resides above the NCP code in controller storage. This can place it above the 4MB boundary. Object code specified with the INCLO and ORDLO keywords resides below the 4MB boundary.

INCINIT specifies the library members that contain linkage-editor INCLUDE statements for user-written initialization code. Modules included in the NCP generation procedure by INCINIT are overlaid after initialization is complete. If you do not want user-written initialization code overlaid, use INCHI or INCLO to specify the library members that contain the linkage-editor INCLUDE statements.

INCL2HI and INCL2LO specify the library members containing linkage-editor INCLUDE statements for object modules that are level 2 or level 3 code. These modules execute with a storage protect key of 0. INCL2HI specifies the object modules residing anywhere in controller storage. If you code INCL2HI, also code ORDL2HI. INCL2LO specifies the object modules that reside in the low 64KB of controller storage. If you code INCL2LO, also code ORDL2LO.

KEY0INC and KEY0ORD specify the library members containing linkage-editor INCLUDE or ORDER statements for object modules to be included in read-only storage.

ORDHI and ORDLO name the library members containing linkage-editor ORDER statements for object modules that are *not* level 2 or level 3 code. ORDHI specifies the object modules residing anywhere in controller storage. ORDLO specifies the object modules residing in the lower 64K of controller storage.

Code ORDINIT only if you code INCINIT. ORDINIT specifies the library members containing linkage-editor ORDER statements for user-written initialization code. The members included in NCP generation by ORDINIT are overlaid after the initialization is complete. If you do not want user-written initialization code overlaid, use

## NDF Standard Attachment Facility

ORDHI or ORDLO to specify the library members containing the ORDER statements.

ORDL2HI and ORDL2LO specify the library members containing linkage-editor ORDER statements for object modules that are level 2 or level 3 code. ORDL2HI identifies object modules residing anywhere in controller storage. ORDL2LO identifies object modules residing in the lower 64K of controller storage.

---

## NDF Standard Attachment Facility

The NDF standard attachment facility enables generation applications to process definition statements, keywords, and linkage editor control statements to customize the generation process. You can write your own generation application to define user-written line control and programmed resources. For information about the NDF standard attachment facility and generation applications, see *NCP, SSP, and EP Generation and Loading Guide*. X.25 users should also see *NCP Version 7 and X.25 NPSI Version 3 Planning and Installation*.

Code the following definition statements and keywords to customize the generation process by providing NCP with information about the name of the load module, and link-level and virtual processing.

OPTIONS	USERGEN
GROUP	LNKOWNER VIROWNER
NCPNAU	VIROWNER

### OPTIONS

USERGEN on the OPTIONS definition statement specifies the names of the generation application load modules or IBM products designated to use the NDF standard attachment facility. Each generation application must have a separate generation application load module to process its definition statements and keywords and generate table source statements. You can specify a maximum of 25 generation load modules in a single generation.

### GROUP

LNKOWNER on the GROUP definition statement specifies the name of the user-written generation load module that does the link-level processing of resources defined on the GROUP definition statement. The name must match one of the user-written generation load module names specified for USERGEN on the OPTIONS definition statement.

VIROWNER names the user-written generation load module that does the virtual processing of resources defined on the GROUP definition statement. The name must match one of the user-written generation load module names specified for USERGEN on the OPTIONS definition statement.

### NCPNAU

VIROWNER on the NCPNAU definition statement specifies the name of the user-written generation load module that owns this NCPNAU definition statement. The

name must match one of the user-written generation load module names specified for USERGEN on the OPTIONS definition statement.





---

## Chapter 14. Interconnected Networks

Interconnected subarea networks are those joined by a gateway NCP and a gateway SSCP. The combination of gateway NCPs and gateway SSCPs enables two or more independently defined subarea networks to communicate with each other while still maintaining their own individual network characteristics, functions, naming, control, evolution, and security.

Interconnected subarea networks are connected to each other by subarea transmission groups. The links in these transmission groups can be any link type which support subarea protocols. See Chapter 12, "Connections between Subarea Nodes" on page 12-1 for more information about subarea connections.

Figure 14-1 on page 14-2 shows how a gateway NCP and a gateway SSCP connect two networks by working together to establish sessions and route data between resources in each network. More complex configurations can have more than one gateway NCP and gateway SSCP connecting two or more networks. See *Planning for Integrated Networks* for descriptions of possible interconnected network configurations.

**Note:** Do not use this chapter if you define NCP to operate in emulation mode.<sup>1</sup>

---

<sup>1</sup> An NCP running in emulation mode does not operate with SNA network interconnection. Therefore, the concept of separate or native and nonnative networks does not apply to devices operating in emulation mode. If a gateway NCP works with the partitioned emulation program (PEP), however, link-attached devices operable in emulation mode can communicate with any channel-attached host processor.

## Defining a Gateway NCP

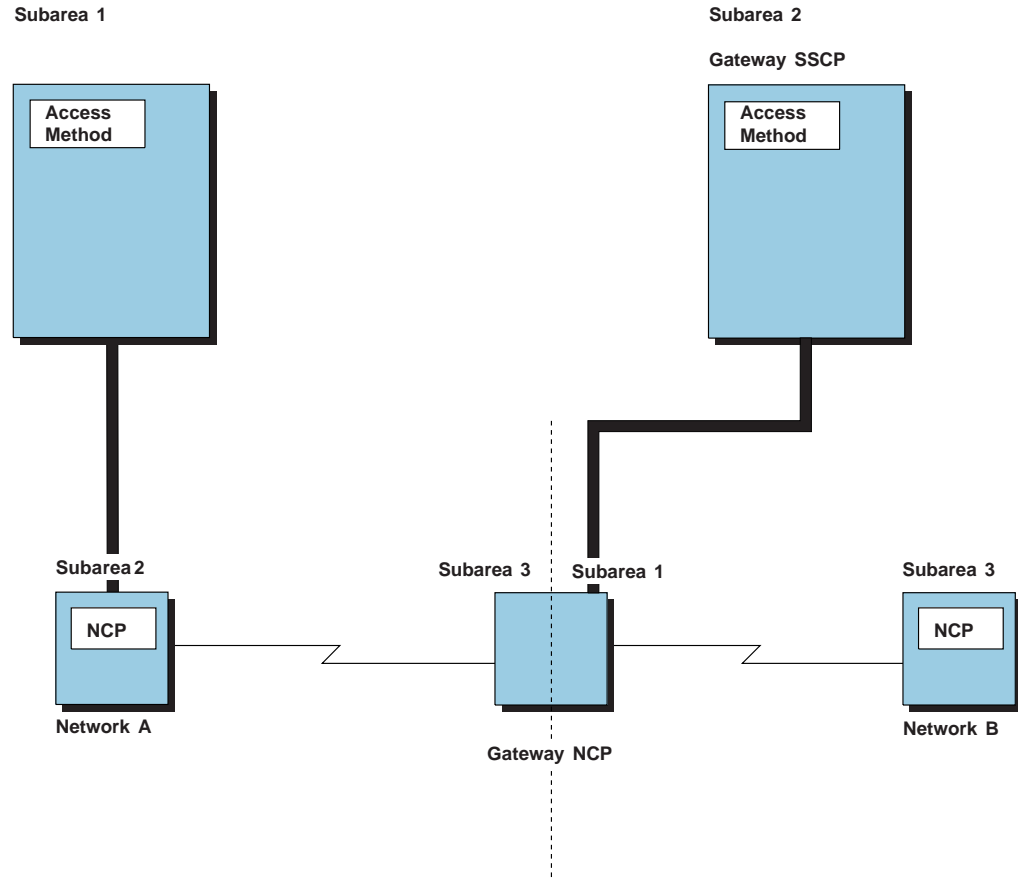

Figure 14-1. Two Networks Connected by a Gateway NCP and a Gateway SSCP

---

## Defining a Gateway NCP

An interconnected network identified by a BUILD definition statement is called a *native network*. It is the network containing the access method that can own any of the resources attached to a gateway NCP. All other interconnected networks are identified by NETWORK definition statements and are called *nonnative networks*.

Although the gateway NCP is only one NCP, it is identified by a subarea address in each network that it joins. For example, in Figure 14-1 the gateway NCP is defined as subarea 3 in network A and subarea 1 in network B. The characteristics and functions of the resources in the native network must be compatible with certain characteristics and functions of all the nonnative networks it joins.

Any interconnected network can be the native network. Native or nonnative status is determined at resource definition time. For example, in Figure 14-1, if you define network A as the native network, only the access method in subarea 1 owns resources attached to the gateway NCP. However, if you define network B as the native network, only the access method in subarea 2 owns these resources.

The access method in which the gateway SSCP resides does not have to own the resources attached to the gateway NCP, although it can. Likewise, the access method in which the gateway SSCP resides does not have to be in the native

network, although it can be. For more information about the SNA network interconnection function, see *Planning for Integrated Networks*.

Code the following definition statement and keywords to provide NCP with a description of the network characteristics and network name for an interconnected network.

```
BUILD          HSBPOOL
                NAMTAB
                NETID
```

HSBPOOL specifies that the generation definition includes the SNA interconnection function and how many half-session control blocks (HSCBs) are to be available for the SSCPs and logical units that participate in cross-network sessions.

NAMTAB defines the maximum number of entries in the network names table. One network names table exists for each NCP. Each entry contains a name and a count of the number of uses for the name. The names stored in this table are SSCP names, control point names, and network names received in various session activation PIUs. See page 2-7 for information about the minimum number of entries that should be coded for this keyword.

NETID names the native network in which the gateway NCP resides.

### Sample Definition of a Gateway NCP

Figure 14-2 shows a sample of a native network configuration with a gateway NCP connecting the native network to a nonnative network.

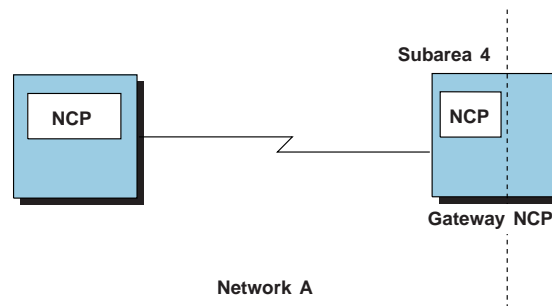

Figure 14-2. Gateway NCP in a Native Network Configuration

Figure 14-3 shows how to define the native network shown in Figure 14-2. The number of entries in the network names table is 30, which is the default.

```
DNETID  BUILD NETID=NETA,      Native network is NETA
          SUBAREA=04,         Subarea 04 in native network
          HSBPOOL=50,         50 HSCBs available
          .
          .
```

Figure 14-3. Example: Defining a Gateway NCP

---

### Defining Nonnative Networks

A nonnative network can communicate with a native network through cross-network sessions if the gateway NCP is defined as a subarea address in the nonnative network. Cross-network sessions include LU-LU, SSCP-SSCP, and FIDO sessions.

Code the following definition statement and keywords to provide NCP with information about network resources, session activation, and the name of the nonnative network.

NETWORK	ACTPU
	COPIES
	ERLIMIT
	MAXSUBA
	NETID
	NUMHSAS
	SALIMIT
	SUBAREA

The NETWORK definition statement is valid only if you code HSBPOOL on the BUILD definition statement to define a gateway NCP. Code one NETWORK statement for each nonnative network.

ACTPU on the NETWORK definition statement specifies whether access methods in the nonnative network can activate the gateway NCP.

COPIES on the NETWORK definition statement not only specifies how many networks can be added concurrently but also causes the other characteristics defined on the NETWORK definition statement to become common characteristics of the dynamically added networks. See “Defining Dynamic Network Allocation” on page 14-18 for more information about the COPIES keyword.

ERLIMIT defines the maximum number of explicit routes supported between subarea pairs in this network. You can define ERLIMIT as either 8 or 16. If you do not code ERLIMIT on the NETWORK definition statement, NCP uses the value coded on the BUILD definition statement; however, if you do not code ERLIMIT on either definition statement, NCP assumes the default of 8 explicit routes. See “Defining Subarea Addressing Limits” on page 4-26 for information on ERLIMIT.

MAXSUBA specifies the largest subarea resource address used by NCPs that do not have extended network addressing ability within a network. The MAXSUBA value must match the MAXSUBA values coded on all other host systems and communication controllers in the nonnative network. For a description of extended network addressing, see “Defining Subarea Addressing Limits” on page 4-26.

NETID identifies the name of the nonnative network.

NUMHSAS specifies the expected number of subareas in the nonnative network that have virtual routes ending in this NCP. The total number of available virtual routes is a combination of the number coded on the NUMHSAS keyword on the BUILD and NETWORK definition statements. Virtual route resources coded on the BUILD or NETWORK definition statement are available for use by any network

## Defining Connections to Adjacent Networks

defined to this NCP. NCP does not keep a separate resource pool for each network.

SALIMIT specifies the largest subarea address supported by a node in the nonnative network. See “Defining Subarea Addressing Limits” on page 4-26 for information on SALIMIT.

SUBAREA identifies the subarea address of the gateway NCP in the nonnative network; if you code SUBAREA on the BUILD definition statement, it identifies the subarea address of the gateway NCP in the native network. For example, in Figure 14-1 on page 14-2, if network A is the native network, network B defines the gateway NCP as subarea 1 and network A defines it as subarea 3. Although the gateway NCP could be given the same subarea address in each network it joins, its address in any one particular network must be a unique address within that network. In Figure 14-1, the gateway NCP could not be defined as subarea 3 in network B because subarea 3 already exists in network B.

### Sample Definition of a Nonnative Network

Figure 14-4 shows the connection of a nonnative network to a gateway NCP.

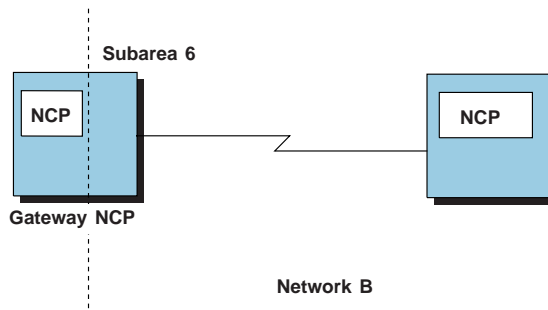

Figure 14-4. Gateway NCP in Nonnative Network Configuration

Figure 14-5 shows how to define the nonnative network shown in Figure 14-4. ACTPU=YES is the default, which means that SSCPs in this nonnative network are allowed to activate the gateway NCP.

NETB	NETWORK NETID=NETB, SUBAREA=06, NUMHSAS=12, .	Nonnative network is NETB Subarea 06 in nonnative network 12 subareas with VRs to this NCP .
------	--	---

Figure 14-5. Example: Defining a Nonnative Network

## Defining Connections to Adjacent Networks

Define the connection to an adjacent network by providing NCP with the name of the adjacent network.

PU	NETID
----	-------

## Defining Connections to Adjacent Networks

NETID on the PU definition statement names the adjacent nonnative network connected by the link station. Although the link station in the adjacent node always resides in the native network and can be activated by access methods in the native network, you should code the name of the nonnative network on the NETID keyword if the adjacent node resides in a nonnative network. If you do not code NETID, the gateway NCP assumes the adjacent node resides in the native network.

You can establish a connection to any of the known nonnative networks over the link by coding NETID=ANY on the PU definition statement. The network ID you code is used as the default network ID for the link, but if you also code ANY on the NETID keyword, any other network ID generated in the NCP is also valid.

Switched subarea lines are identified during link activation. For nonswitched subarea lines, the network ID is passed at negotiation time. If the network ID defaults differ, negotiation can be performed when one or both network definitions contain NETID=ANY.

In Figure 14-6, the link station connecting NCP subarea 3 resides in the gateway NCP and is activated by access methods in network A, the native network. However, NCP subarea 3 itself resides in network B. Therefore, the NETID associated with the link station connecting NCP subarea 3 to the gateway NCP must be the name of network B.

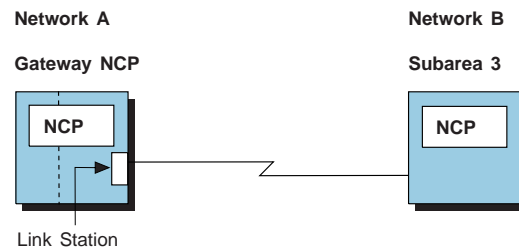

Figure 14-6. Link Station Representing NCP in Nonnative Network

When you define two adjacent gateway NCPs to each other (in separate generation definitions), the link stations at the ends of a subarea link connecting two gateway NCPs must both be defined to reside in the same network. Code the same NETID on each PU definition statement that defines a link station connecting one NCP to another. Use this rule when defining adjacent gateway NCPs in multiple or back-to-back configurations. For example, in Figure 14-6, if NCP subarea 3 were another gateway NCP, both of the NETID keywords on the PU definition statements that define each link station would define the name of the null network created by the back-to-back configuration. See *Planning for Integrated Networks* for more information about back-to-back configurations.

Figure 14-7 on page 14-7 shows a more complex configuration with link stations in different networks at the ends of two subarea links connecting two gateway NCPs. Although subarea link 1 and subarea link 2 both connect gateway NCP1 to gateway NCP2, the link stations at the ends of subarea link 1 reside in network A, while the link stations at the ends of subarea link 2 reside in network B.

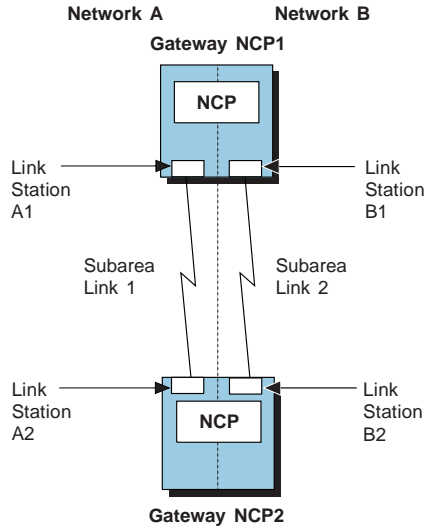

Figure 14-7. Link Stations Representing Adjacent Gateway NCPs

**Sample Definition of a Connection to an Adjacent Network**

Figure 14-8 shows a sample network configuration with a link station in a nonnative network.

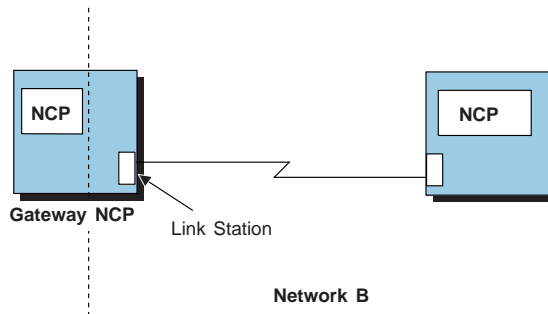

Figure 14-8. Link Station in Nonnative Network

Figure 14-9 shows how to define the link station shown in Figure 14-8.

GSW	GROUP NETID=(NETB,ANY)	Links are to NETB and any others
*	.	
LSW	LINE .	
*	.	
PSW	PU PUTYPE=4,	Link station to adjacent NCP
	.	
	.	

Figure 14-9. Example: Defining Nonnative Network Connections

## Defining Cross-Network Sessions

The gateway NCP reserves two types of control blocks to support cross-network sessions between an SSCP or logical unit in one network and an SSCP or logical unit in another network: address control blocks and half-session control blocks (HSCBs).

### Address Control Blocks

Address control blocks enable the gateway NCP to assign alias addresses to SSCPs or logical units that reside in, and have real addresses in, one network, but that participate in sessions with SSCPs or logical units in another network. For example, in Figure 14-10 TERMA1 in network A can participate in a session with IMSB in network B (both TERMA1 and IMSB are logical units, so this represents an LU-LU session). For TERMA1 to be able to participate in a session with IMSB, IMSB must appear to TERMA1 to reside in network A. Likewise, TERMA1 must appear to IMSB to reside in network B. By reserving address control blocks, the gateway NCP is able to assign an alias address to IMSB, making it appear as if it resides in network A. The gateway NCP does the same for TERMA1 to make it appear as if it resides in network B.

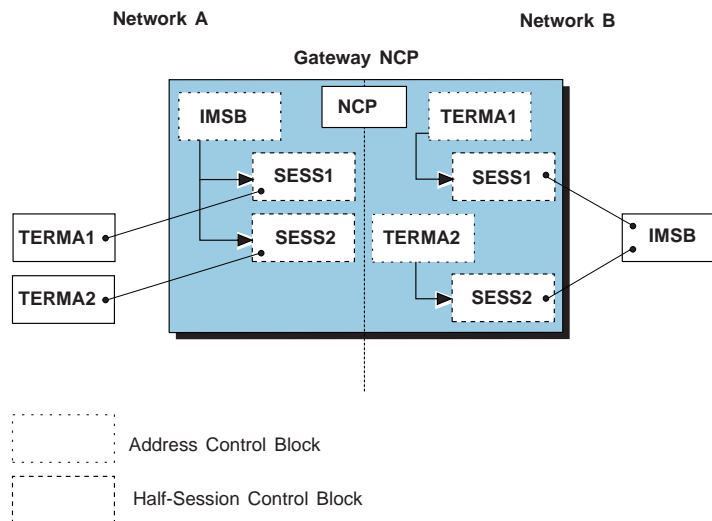

Figure 14-10. Address Control Blocks and HSCBs Used to Represent Cross-Network Sessions

Each cross-network session uses an address control block that represents each of the two session partners. However, some logical units can participate in multiple concurrent sessions, and although they can participate in more than one session at the same time, they require only one address. In Figure 14-10, IMSB can participate in concurrent sessions with both TERMA1 and TERMA2, but requires only one address to represent it in network A. In network B, however, TERMA1 and TERMA2, because they can each participate in only one session at a time, require separate addresses to represent them. In this case, two sessions are possible, but only three addresses are required. Had IMSB been an application program such as TSO, which participates in only one session at a time, four addresses would have been required: the first to represent TSO to TERMA1 in network A, the second to represent TSO to TERMA2 in network A, the third to represent TERMA1 to TSO in network B, and the fourth to represent TERMA2 to TSO in network B.



You can reserve address control blocks in two ways: by defining specific addresses or by defining a pool of addresses. If you define specific addresses, they are always reserved and assigned to the same SSCPs or logical units whenever those SSCPs or logical units participate in cross-network sessions. If you define a pool of addresses, the gateway NCP assigns an alias address whenever one is needed to establish a cross-network session. The gateway NCP returns the address to the pool when the session ends.

### Defining Addresses

You can define specific addresses to be assigned to an SSCP or to a logical unit. Code the following definition statement and keywords to provide NCP with the assigned address, SSCP name, and network name.

GWNAU	ELEMENT NAME NETID
-------	--------------------------

ELEMENT on the GWNAU definition statement specifies the element address to be assigned to the SSCP or logical unit. Define ELEMENT only when assigning a specific element address to a resource that is to participate in cross-network sessions.

NAME specifies the name associated with the defined element address of an SSCP or logical unit. This is the name the resource is known by in its own network.

NETID identifies the network that contains the SSCP or logical unit.

### Defining a Pool of Addresses

You can define a pool of addresses to be used in cross-network sessions. Code the following definition statement and keyword to provide NCP with a definition of the address pool limits.

GWNAU	NUMADDR
-------	---------

NUMADDR on the GWNAU definition statement specifies the number of addresses the gateway NCP reserves in a pool to represent SSCPs and logical units that participate in cross-network sessions with SSCPs and logical units in the network.

#### Notes:

1. The location of the GWNAU definition statements in your NCP generation definition determines the network to which the cross-network session addresses are assigned. See "Placement of GWNAU Definition Statements" on page 14-12 for more information.
2. You can cause NCP to dynamically create additional addresses for cross-network sessions when needed. See "Dynamically Created Control Blocks" on page 2-10 for more information.

### Half-Session Control Blocks

In addition to reserving address control blocks to represent SSCP and logical units that participate in cross-network sessions, the gateway NCP also reserves HSCBs to represent each session. HSCBs are assigned to address control blocks and represent the number of concurrent sessions the SSCP or logical unit can participate in. The address control block representing IMSB in network A (Figure 14-10 on page 14-8) has two HSCBs associated with it. These HSCBs represent the number of concurrent sessions IMSB can participate with in network A: one with TERMA1 and one with TERMA2. Unlike the assignment of addresses, where one address sometimes represents multiple concurrent sessions, two HSCBs are required for each cross-network session that occurs. This means the assignment of HSCBs requires that one HSCB be assigned to *each* session partner. Therefore, in Figure 14-10, although IMSB requires only one address for its multiple sessions with TERMA1 and TERMA2 in network A, it requires two HSCBs to be associated with these sessions. TERMA1 and TERMA2 each require one HSCB in network B, indicating that they each participate in one session at a time.

You can reserve HSCBs in two ways: by defining a specific number of HSCBs or a pool of HSCBs. If you define a specific number of HSCBs, the same number of HSCBs is always reserved and assigned to the same specifically defined address control block whenever the SSCP or logical unit participates in cross-network sessions. If you define a pool of HSCBs, the gateway NCP assigns the required number of HSCBs to an address control block whenever they are needed to establish a cross-network session. The gateway NCP returns the HSCBs to the pool when the session ends.

#### Defining HSCBs

You can define a specific number of HSCBs to be used when SSCPs or logical units establish cross-network sessions. Code the following definition statement and keyword to provide NCP with information about the number of HSCBs to be reserved.

<code>GWNAU</code>	<code>NUMSESS</code>
--------------------	----------------------

NUMSESS specifies the number of HSCBs the gateway NCP reserves and assigns to the address control block whenever the SSCP or logical unit establishes a session. Code NUMSESS on the same GWNAU definition statement that defines an address control block. The NUMSESS value defines how many cross-network sessions the SSCP or defined logical unit can participate in simultaneously. If the value of SESSLIM on the BUILD definition statement for the native network or the NETWORK definition statement for the nonnative network is greater than the NUMSESS value, the gateway NCP can dynamically assign HSCBs from the pool to that defined address, if needed, until the SESSLIM value is reached. When the sessions involving the defined addresses end, the gateway NCP returns these HSCBs to the pool.

### Defining a Pool of HSCBs

You can define a pool of HSCBs to be used when SSCP or logical units establish cross-network sessions. Code the following definition statements and keywords to provide NCP with information about the number of HSCBs in the pool and how to enhance session performance.

BUILD	HSBPOOL NETLIM SESSLIM
NETWORK	NETLIM SESSLIM

#### BUILD

HSBPOOL on the BUILD definition statement specifies how many HSCBs the gateway NCP reserves in a pool for SSCP and logical units that can participate in cross-network sessions. The HSBPOOL total should equal at least twice the number of concurrent cross-network sessions you expect to occur through your gateway NCP. Recognize that cycle and storage usage affects HSCBs when you code HSBPOOL.

**Note:** You can cause NCP to dynamically create additional HSCBs for cross-network sessions when needed. See “Dynamically Created Control Blocks” on page 2-10 for more information.

NETLIM specifies how many HSCBs can be assigned at any given time to all addresses in the native network.

SESSLIM on the BUILD definition statement specifies the maximum number of HSCBs assigned to any address in the native network. Although the address resides in the native network, the SSCP or logical unit it represents resides in a nonnative network. The number coded on SESSLIM restricts the number of concurrent sessions the SSCP or logical unit can participate in with resources in the native network.

#### NETWORK

**Note:** The NETWORK definition statement is valid only if you code HSBPOOL on the BUILD definition statement.

NETLIM on the NETWORK definition statement specifies how many HSCBs can be assigned at any given time to all addresses in the nonnative network. The sum of the NETLIM values coded on the BUILD and all NETWORK definition statements for native and nonnative networks is the total number of HSCBs that can be concurrently assigned to all addresses. This prevents any single network connected through the gateway NCP from monopolizing the HSCB pool.

SESSLIM on the NETWORK definition statement specifies the maximum number of HSCBs assigned to any address in the nonnative network. Although the address resides in the nonnative network, the SSCP or logical unit it represents resides in another network. This other network can be the native network or another nonnative network. The value of SESSLIM limits the number of concurrent sessions the SSCP or logical unit can participate in with resources in the nonnative network.

### Placement of GWNAU Definition Statements

GWNAU definition statements, whether they define a pool of addresses or define specific addresses, follow either the SYSCNTRL or NETWORK definition statement in the NCP generation definition. However, GWNAU definition statements defining specific addresses come before GWNAU definition statements defining a pool of addresses.

Although the BUILD definition statement defines characteristics about the native network, GWNAU definition statements that follow the SYSCNTRL definition statement do not define characteristics of the SSCPs and logical units in the native network. Instead, they define values for SSCPs and logical units in a nonnative network that participate in sessions with the native network. In the same manner, GWNAU definition statements that follow the NETWORK definition statement define values for SSCPs and logical units in any network (including the native network) that participate in sessions with SSCPs and logical units in the nonnative network defined by the NETWORK definition statement.

For example, in Figure 14-11, LU2 and LU3, residing in network B, can participate in sessions with LU1, residing in network A. To participate in cross-network sessions with LU1, LU2 and LU3 must appear to LU1 as if they are in network A. Likewise, LU1 must appear to LU2 and LU3 as if it is in network B. If network A is the native network, the GWNAU definition statements that define values for LU2 and LU3 must follow the SYSCNTRL definition statement. GWNAU definition statements defining values for LU1 must follow the NETWORK definition statement that defines network B.

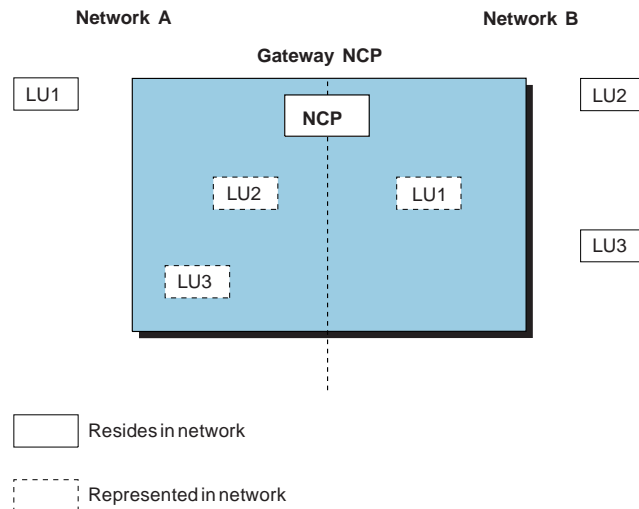

Figure 14-11. Logical Units Requiring Cross-Network Session Specifications

If LU2 and LU3 are dynamically allocated addresses from a pool for participation in cross-network sessions with LU1, the cross-network session values for LU2 and LU3 in network A are defined in the gateway NCP, as shown in Figure 14-12.

BUILD	NETID=A, HSBPOOL=4, SESSLIM=1, NETLIM=2, . .	Native network is network A 4 HSCBs available Limit 1 session per native resource Limit 2 sessions for all native rscs
SYSCNTRL	.	
GWNAU	NUMADDR=2	2 NAU addresses available for native network

Figure 14-12. Example: Defining Cross-Network Session Values

The GWNAU definition statement in this example follows the SYSCNTRL definition statement. It defines resources in a nonnative network to be connected to the native network through a cross-network session. NUMADDR on the GWNAU definition statement specifies that two addresses reserved by the gateway NCP are to be assigned to two resources (LU2 and LU3) in network A. SESSLIM and NETLIM on the BUILD definition statement are also coded to affect cross-network resources. SESSLIM specifies the maximum number of HSCBs assigned to a resource in the native network (LU2 and LU3); this limits them to one session each with the resource defined in nonnative network B. NETLIM limits the maximum number of HSCBs the native network assigns to two, one for LU2 and one for LU3.

Unlike SESSLIM and NETLIM, HSBPOOL on the BUILD definition statement defines characteristics of SSCPs and logical units in all networks. The value coded specifies that the gateway NCP is to reserve four HSCBs for cross-network sessions between LU1, LU2, and LU3. These are allocated as follows: one for LU1 and one for LU2 when they are in session, and one for LU1 and one for LU3 when they are in session. LU1 can be in session with both LU2 and LU3 at the same time, and therefore requires two HSCBs. (In Figure 14-11 on page 14-12, LU1 is probably a subsystem, such as CICS, while LU2 and LU3 are probably terminals.)

In the same way that LU2 and LU3 are defined to appear in network A, LU1 must be defined to appear in network B, as shown in Figure 14-13. These statements and keywords define dynamic allocation of addresses and are in the same definition of the gateway NCP as the BUILD, SYSCNTRL, and GWNAU definition statements listed previously.

NETWORK	NETID=B, SESSLIM=2, NETLIM=2, . .	Nonnative network is network B Limit 2 sessions per nonnative resource Limit 2 nonnative network sessions
GWNAU	NUMADDR=1	1 NAU address available for nonnative network

Figure 14-13. Example: Defining Dynamic Allocation of Addresses

The GWNAU definition statement in this example follows the NETWORK definition statement defining network B. This indicates that the GWNAU definition statement defines resources in another network (which could be the native network, as it is in this case, or another nonnative network) that must be represented in network B. NUMADDR on the GWNAU definition statement specifies that one address must be reserved by the gateway NCP to represent LU1 in network B. SESSLIM and

## Defining Cross-Network Sessions

NETLIM on the NETWORK definition statement also define characteristics for resources in another network represented in network B. SESSLIM specifies that LU1 can participate in a maximum of two sessions, one with LU2 and one with LU3. NETLIM specifies that the maximum number of HSCBs that the gateway NCP assigns to LU1 is two, one for when it is in session with LU2 and one for when it is in session with LU3. In Figure 14-12 on page 14-13, HSBPOOL on the BUILD definition statement reserves two HSCBs for LU1 when LU1 is in session simultaneously with LU2 and LU3.

Figure 14-14 shows the definition statements and keywords coded in the gateway NCP if LU2 and LU3 are permanently assigned addresses for participation in cross-network sessions with LU1.

```
BUILD  NETID=A,           Native network is network A
      .
      .
SYSCNTRL
      .
      .
GWNAU  NETID=B,           Gateway NAU for network B side
      NAME=LU2,           Network B LU name is LU2
      NUMSESS=1           1 session allowed
GWNAU  NETID=B,           Gateway NAU for network B side
      NAME=LU3,           Network B LU name is LU3
      NUMSESS=1           1 session allowed
```

Figure 14-14. Example: Defining Cross-Network Sessions in the Gateway NCP

The GWNAU definition statements in this example follow the SYSCNTRL definition statement, indicating that they define characteristics for resources in a nonnative network that can participate in sessions with LU1 in the native network. This example also has two GWNAU definition statements, one for each logical unit represented in network A. The NETID keywords on these definition statements indicate that the logical units they define reside in network B. The NAME keywords specify the names of the logical units, and the NUMSESS keywords indicate that each logical unit participates in only one session with LU1.

Figure 14-15 shows the definition statements and keywords used to define LU1 to network B in the same definition of the gateway NCP. These definition statements and keywords also define permanent assignment of an address.

```
NETWORK NETID=B,           Nonnative network is network B
      .
      .
GWNAU  NETID=A,           Gateway NAU for native side
      NAME=LU1,           Native network LU name is LU1
      NUMSESS=2           2 sessions allowed
```

Figure 14-15. Example: Defining a Logical Unit in the Gateway NCP

The GWNAU definition statement in this example follows the NETWORK definition statement that defines network B, indicating that this GWNAU definition statement defines resources in another network that participate in sessions with LU2 and LU3 in network B. The NETID keyword of this definition statement indicates that the logical unit it defines resides in network A. NAME specifies the name of the logical

unit, and NUMSESS indicates that the maximum number of sessions the logical unit can participate in with LU2 and LU3 is two.

## Defining Cross-Network Paths

A path between a pair of networks consists of as many separate explicit routes as the number of networks the path passes through. Define these explicit routes independently for each network. The definition statements and keywords used to define cross-network paths between interconnected networks are the same definition statements and keywords used to define routes between subareas in an independent network.

The explicit routes for each network need not have the same explicit route number. For example, in Figure 14-16, data traveling from VTAM subarea 1 in network A to NCP subarea 5 in network B travels over an explicit route defined in network A as ER0 and over a separate explicit route defined in network B as ER1.

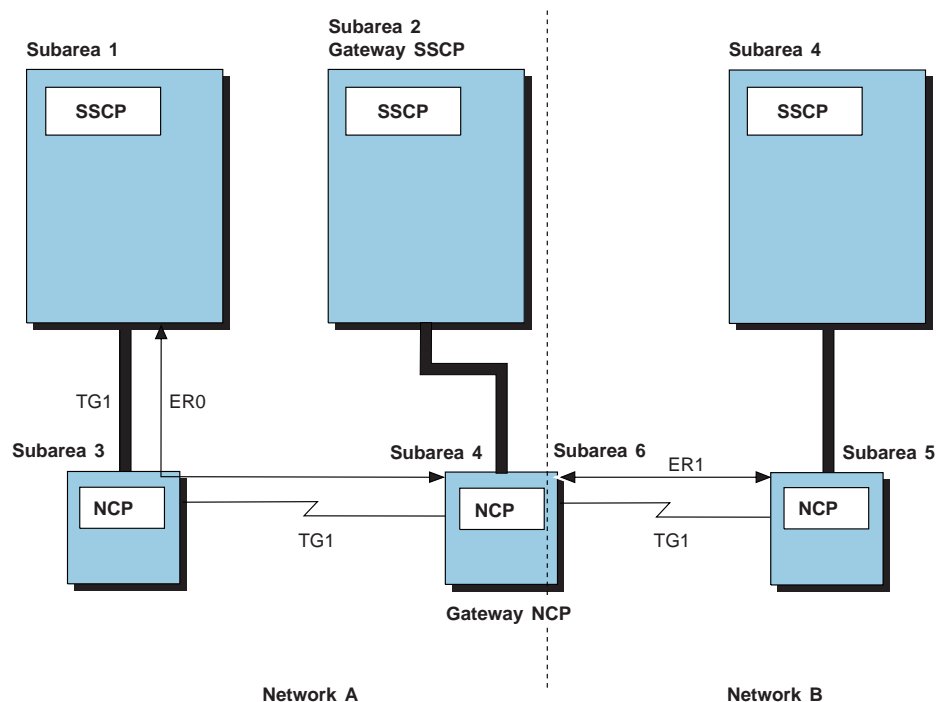

Figure 14-16. An Interconnected Network with a Cross-Network Path

Between any two adjacent networks in a cross-network path, the gateway NCP serves as a destination subarea and an origin subarea for the explicit routes comprising the path. In network A (Figure 14-16) the gateway NCP serves as the destination subarea of ER0 (defining forward data flow) from VTAM subarea 1 and as the origin subarea of ER0 (defining reverse data flow) to VTAM subarea 1. Likewise, in network B the gateway NCP serves as the origin subarea of ER1 (defining forward data flow) to NCP subarea 5 and as the destination subarea of ER1 (defining reverse data flow) from NCP subarea 5.

Code the following definition statements and keywords to provide NCP with information about cross-network routes and paths and how to improve NCP performance.

## Defining Cross-Network Paths

NETWORK	ERLIMIT
PATH	DESTSA ER $n$ VR $n$ VRPWS $nm$

### NETWORK

ERLIMIT on the NETWORK definition statement defines how many explicit routes are to be supported between subarea pairs in a nonnative network. You can define as many as 16 explicit routes; however, if you omit ERLIMIT, the default is 8 explicit routes. If you do not code ERLIMIT on the NETWORK definition statement, NCP uses the value coded on the BUILD definition statement.

### PATH

DESTSA on the PATH definition statement specifies the subarea address of a destination subarea that is the end point in an explicit route. The destination subarea can be either an access method or another NCP. Multiple destination subareas can be defined on one PATH definition statement; however, it is recommended that each destination subarea be identified with a unique path definition statement.

ER $n$  assigns an explicit route number to each explicit route that either originates in or passes through NCP on its way to the destination subarea defined by DESTSA on the PATH definition statement. Identify the adjacent subarea that will forward data over the explicit route to the destination subarea, the explicit route number, and flow-control thresholds.

The explicit route number can be a value from 0 to 15. ER8 through ER15 are valid only if you specify 16 explicit routes on ERLIMIT on the BUILD definition statement. You can set transmission group congestion thresholds by specifying low, medium, high, and total flow-control thresholds. When a threshold is exceeded, flow-control congestion indicators are included in the PIUs sent to destination subareas, notifying these destination subareas of the congestion situation. Appropriate flow-control actions then take place.

**APPN HPR:** The total flow-control threshold can also be used to specify the limit on the number of bytes of APPN HPR data that can be queued on the transmission group at one time. When the threshold is exceeded, NCP discards additional APPN HPR data that arrives. This causes the RTP endpoints to reduce the rate at which they send APPN HPR data into the subarea network of the composite ANR node.

ER $n$  keywords define entire routes through the network. However, these routes are made up of segments that must be defined in each subarea which originates a route or functions as an intermediate subarea along the explicit route.

VRPWS $nm$  defines the minimum and maximum virtual route pacing window sizes in support of high-speed or long-delay transmission facilities (for example, satellites) for the virtual routes. Valid values for  $n$  are 0 to 7. For each virtual route, you can code 0, 1, or 2 for an  $m$  value to establish three levels of priority for minimum and maximum virtual route pacing window sizes.



VR*n* defines a virtual route to be assigned to an explicit route defined by the same PATH definition statement. They are numbered VR0 through VR7 and correspond directly to the assigned explicit route number.

Use the following guidelines to assign virtual routes in NCP:

- You can assign a number from 0 to 7 as a virtual route number.
- You can assign many virtual routes to the same explicit route. If an explicit route becomes inoperative, the virtual routes using it are no longer available for session traffic.
- Do not assign the same virtual route to more than one explicit route between an origin subarea and a destination subarea.
- If you define a virtual route between your NCP and a subarea that can also activate the same virtual route, assign the same virtual route number to:

The explicit route in the origin subarea that defines the route's forward data flow

The explicit route in the destination subarea that defines the route's reverse data flow.

**Note:** The PATH definition statements defining explicit routes from the gateway NCP to destination subareas in a nonnative network must follow the NETWORK definition statement that defines its nonnative network. These PATH definition statements also must follow the GWNAU definition statements defining cross-network session characteristics for resources in another network that can participate in sessions with resources in the nonnative network defined by the NETWORK definition statement. If the PATH definition statement defines explicit routes from the gateway NCP to destination subareas in the native network, it must also follow its associated GWNAU definition statements. These GWNAU definition statements define cross-network session characteristics for resources in a nonnative network that can participate in sessions with resources in the native network.

### Sample Definition of Cross-Network Paths

Figure 14-17 on page 14-18 shows PATH definition statements that define the cross-network path from VTAM subarea 1 to NCP subarea 5 shown in Figure 14-16 on page 14-15. Figure 14-17 also shows the PATH statements that define the reverse path over which data travels from NCP subarea 5 to VTAM subarea 1.

## Defining Dynamic Network Allocation

NETA Subarea 1 to NETB Subarea 5		NETB Subarea 5 to NETA Subarea 1	
<b>In NETA Subarea 1:</b>	PATH DESTSA=4, ER0=(3,1), VR0=0	<b>In NETB Subarea 5:</b>	PATH DESTSA=6, ER1=(1,1)
<b>In NETA Subarea 3:</b>	PATH DESTSA=4, ER0=(4,1)	<b>In Gateway NCP:</b>	BUILD NETID=NETA, SUBAREA=4, . . GWNAU . 1 . . PATH DESTSA=1, ER0=(3,1), VR0=0, . .
<b>In Gateway NCP:</b>	BUILD NETID=NETA, SUBAREA=4, . . NETWORK NETID=B, SUBAREA=6, . . GWNAU . 2 . . PATH DESTSA=5, ER1=(5,1), VR1=1	<b>In NETA Subarea 3:</b>	PATH DESTSA=1, ER0=(1,1)
1	Gateway path to native network		
2	Gateway path to nonnative network		

Figure 14-17. Example: Defining Cross-Network Paths

## Defining Dynamic Network Allocation

In addition to the explicit definition of a network (described in “Defining a Gateway NCP” on page 14-2), the gateway NCP can dynamically allocate or deallocate network resources if you define a model network that can be replicated when the gateway NCP receives an unknown network identifier (NETID). The gateway NCP uses the dynamically added network for all sessions with this NETID. When all sessions with this NETID have ended, the gateway NCP frees the dynamically allocated network.

Varying levels of the dynamic network allocation function are supported. The level of variation depends on the level of the NCP in the adjacent subarea node. See *NCP and EP Reference* for more detailed information on the dynamic network allocation function.

Code the following definition statement and keyword to provide NCP with the number of network copies permitted for dynamic allocation.

```
NETWORK    COPIES
```

COPIES on the NETWORK definition statement not only defines how many networks can be added concurrently but also causes the other characteristics defined on the NETWORK definition statement to become common characteristics of the dynamically added networks. The maximum value for COPIES depends on how

many explicit networks are defined. The total number of nonnative networks (the number of explicit networks plus the number of dynamically added networks) cannot exceed 254. If the NETWORK definition statement coded with the COPIES keyword is not the last NETWORK statement, the maximum number of nonnative networks cannot exceed 253.

When you define the network model, omit the NETID keyword from the NETWORK definition statement and replace it with the COPIES keyword. The remaining keywords on the NETWORK definition statement determine the common characteristics of any dynamically allocated network. All GWNAU and PATH definition statements that follow this NETWORK definition statement complete the definition of the dynamic network model. The PATH definition statement defines a route to the adjacent subarea. For dynamically added networks, code a separate PATH definition statement for each unique subarea and transmission group combination that can be used during XID exchange processing.

You can minimize the number of PATH definition statements defined under this NETWORK definition statement by defining the adjacent subarea for all possible nonnative networks to be dynamically allocated with the same subarea number and by defining the subarea links with the same transmission group number.

### Sample Definition of a Dynamically Added Network

Figure 14-18 shows how to provide connections for six nonnative networks to be dynamically added to an NCP node.

COPIES	NETWORK COPIES=6,	6 nonnative networks supported
	SUBAREA=05,	Subarea 05 in nonnative networks
	NUMHSAS=12,	12 subarea VRs from each network
	.	
	.	

Figure 14-18. Example: Defining the Number of Dynamically Added Networks

## Defining Dynamic Network Allocation

Figure 14-19 shows five interconnected networks, each containing a gateway NCP. The gateway NCP in network A is in a back-to-back configuration with the other four NCPs. The dummy networks XBA, XCA, XDA, and XEA support this back-to-back configuration.

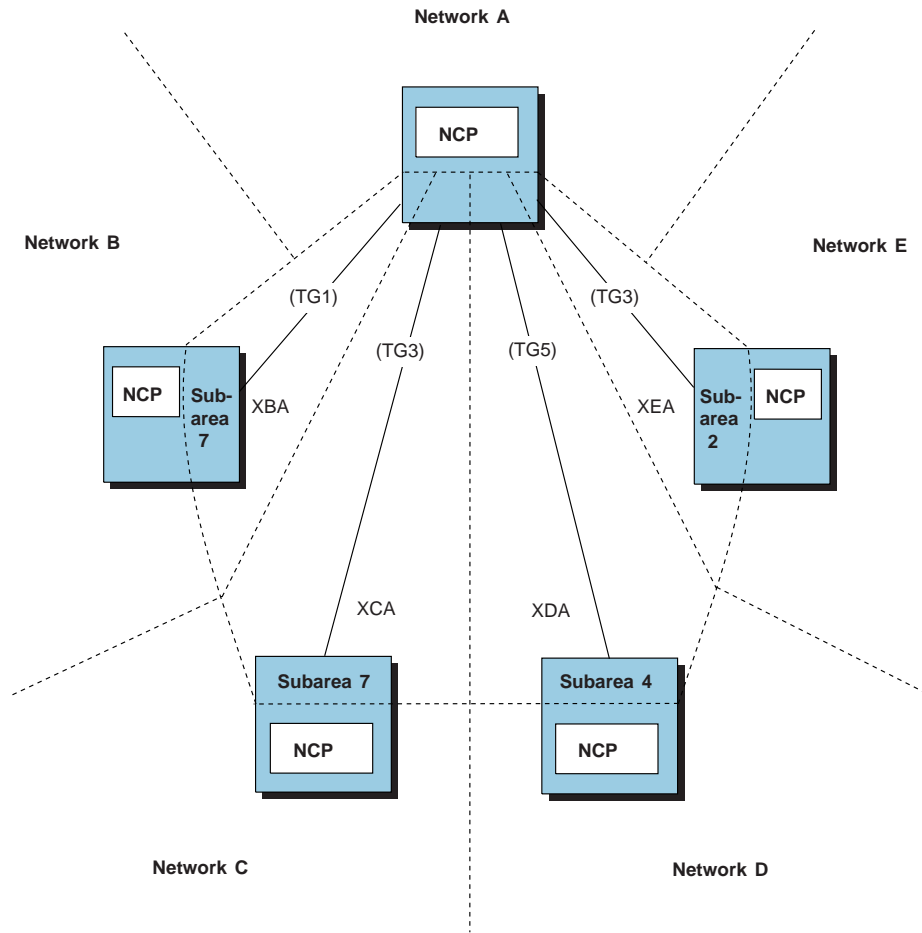

Figure 14-19. Back-to-Back Configuration with Five NCPs. The dotted lines represent network boundaries.

Figure 14-20 shows how to define the configuration shown in Figure 14-19 on page 14-20. The gateway NCP in network A supports up to two dynamically added networks. This requires three separate PATH definition statements because of the variety of possible subarea and transmission group combinations required to connect all the possible adjacent networks shown in Figure 14-19 on page 14-20.

```

Network A Gateway: BUILD NETID=A,
                        SUBAREA=9,
                        .
                        .
                        NETWORK COPIES=2,
                        .
                        .
                        GWNAU .
                        .
                        PATH  DESTSA=2,
                        ER0=(2,3),
                        VR1=0
                        PATH  DESTSA=4,
                        ER0=(4,5),
                        VR1=0
                        PATH  DESTSA=7,
                        ER0=(7,1),
                        ER1=(7,3),
                        VR1=0,
                        VR2=1

Network B Gateway: BUILD NETID=B,
                        .
                        .
                        NETWORK NETID=XBA,
                        SUBAREA=7,
                        .
                        .
                        GWNAU .
                        .
                        PATH  DESTSA=9,
                        ER0=(9,1),
                        VR1=0

Network E Gateway: BUILD NETID=E,
                        .
                        .
                        NETWORK NETID=XEA,
                        SUBAREA=2,
                        .
                        .
                        GWNAU .
                        .
                        PATH  DESTSA=9,
                        ER0=(9,3),
                        VR1=0

Network C Gateway: BUILD NETID=C,
                        .
                        .
                        NETWORK NETID=XCA,
                        SUBAREA=7,
                        .
                        .
                        GWNAU .
                        .
                        PATH  DESTSA=9,
                        ER0=(9,3),
                        VR1=0

Network D Gateway: BUILD NETID=D,
                        .
                        .
                        NETWORK NETID=XDA,
                        SUBAREA=4,
                        .
                        .
                        GWNAU .
                        .
                        PATH  DESTSA=9,
                        ER0=(9,5),
                        VR1=0
    
```

Figure 14-20. Example: Defining PATH Statements for Dynamically Added Networks

## Defining Dynamic Network Allocation

Figure 14-21 shows how you can minimize the number of cross-network paths required for the gateway NCP in network A by defining the cross-network resources of the adjacent subarea with the same subarea and transmission group values.

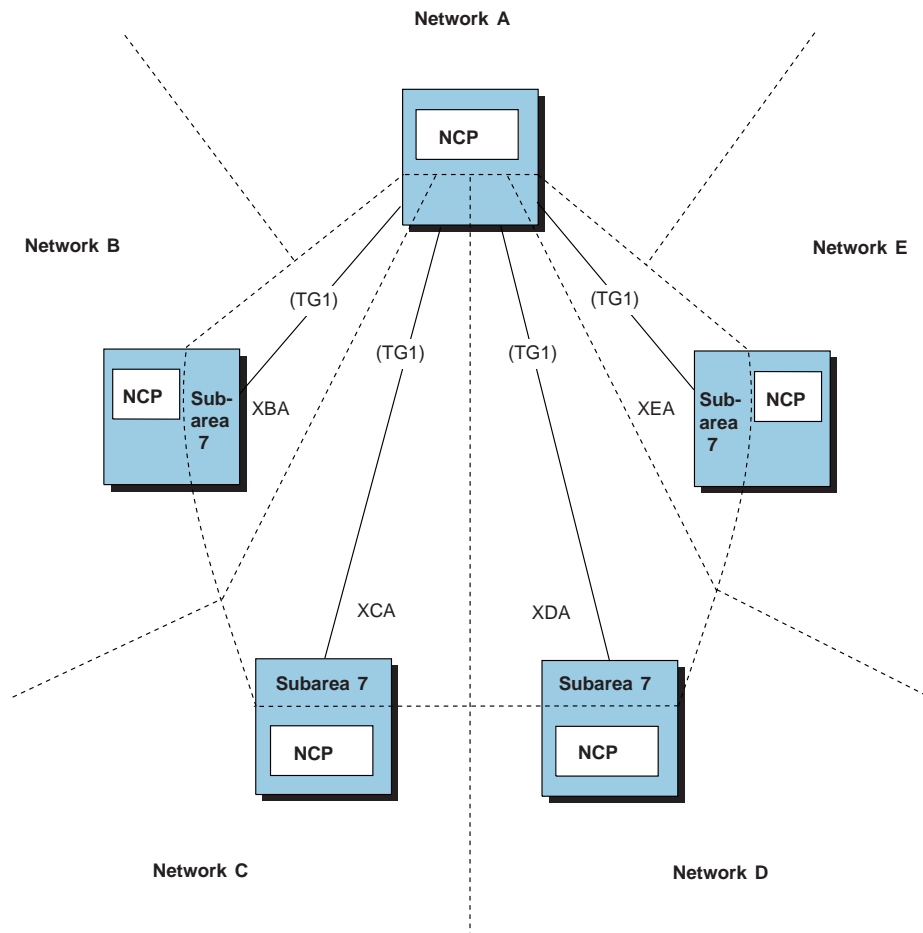

Figure 14-21. Back-to-Back Configuration with Five NCPs (Optimized). The dotted lines represent network boundaries.

Figure 14-22 shows how to define the optimized back-to-back NCP configuration shown in Figure 14-21 on page 14-22.

```

Network A Gateway: BUILD NETID=A,
                        SUBAREA=9,
                        .
                        .
                        NETWORK COPIES=2,
                        .
                        .
                        GWNAU .
                        .
                        PATH  DESTSA=7,
                        ER0=(7,1),
                        VR1=0

Network B Gateway: BUILD NETID=B,
                        .
                        .
                        NETWORK NETID=XBA,
                        SUBAREA=7,
                        .
                        .
                        GWNAU .
                        .
                        PATH  DESTSA=9,
                        ER0=(9,1),
                        VR1=0

Network C Gateway: BUILD NETID=C,
                        .
                        .
                        NETWORK NETID=XCA,
                        SUBAREA=7,
                        .
                        .
                        GWNAU .
                        .
                        PATH  DESTSA=9,
                        ER0=(9,1),
                        VR1=0

Network E Gateway: BUILD NETID=E,
                        .
                        .
                        NETWORK NETID=XEA,
                        SUBAREA=7,
                        .
                        .
                        GWNAU .
                        .
                        PATH  DESTSA=9,
                        ER0=(9,1),
                        VR1=0

Network D Gateway: BUILD NETID=D,
                        .
                        .
                        NETWORK NETID=XDA,
                        SUBAREA=7,
                        .
                        .
                        GWNAU .
                        .
                        PATH  DESTSA=9,
                        ER0=(9,1),
                        VR1=0
    
```

Figure 14-22. Example: Defining PATH Statements to a Dynamically Added Network (Optimized)

## Defining Cross-Network Paths to VTAM

Code the following definition statements and keywords to provide VTAM with information about the class of service table.

BUILD	COSTAB
NETWORK	COSTAB

## Defining Gateway Session Accounting

COSTAB on the BUILD and NETWORK definition statements is a VTAM keyword used to define a class of service table for a gateway NCP. See *VTAM Resource Definition Reference* for a description of this keyword.

---

## Defining Cross-Network Session Pacing

Code the following definition statements and keywords to provide NCP with information about the pacing window, the type of pacing, and what action to take when a BIND request is processed.

BUILD	GWPACING
NETWORK	GWPACING

GWPACING on the BUILD and NETWORK definition statements establishes pacing for cross-network sessions. If session BIND processing results indicate that the session will run unpaced, the gateway NCP forces the session to use session pacing.

---

## Defining Gateway Session Accounting and Accounting Exit Routines

You can create user-written accounting exit routines for cross-network sessions, or you can use the NPM data collection facility to collect statistics about gateway cross-network sessions. You can track the following data for LU-LU, FIDO, and SSCP-SSCP sessions:

- Names of session partners (PLU and SLU)
- Network identifiers of the session partners
- PLU and SLU alias names
- Session start and end times
- Virtual route used for the session
- Transmission priority used for the session
- Explicit route used for the session
- Number of control PIUs sent and received
- Number of text PIUs sent and received
- PIU by size frequency counts (control and text).

Code the following definition statements and keywords to provide NCP with information about how to establish user-written accounting exit routines or invoke the NPM data collection facility.

BUILD	GWAEXIT GWSESAC NPA SESSACC
-------	--------------------------------------

GWAEXIT on the BUILD definition statement names a user-written accounting exit routine for cross-network sessions. Code the name exactly as it is known in the user library identified by INCHI and ORDHI on the GENEND definition statement.



GWSESAC enables you to include the gateway session accounting function in your NCP. Code GWSESAC to specify:

- Whether you want your NCP to collect cross-network accounting information.
- Whether you want to defer data collection.
- The number of NPM session counter control blocks (NSCs) and NSC extensions (NSXs) NCP is to create for gateway session accounting.

**Note:** You can cause NCP to dynamically create additional NSCs and NSXs when needed. See “Dynamically Created Control Blocks” on page 2-10 for more information.

- The number of bytes or PIUs counted before cross-network accounting data is sent to NPM.
- PIU by size frequency counts (control and text).
- Whether the procedure-correlation identifier (PCID) received during session setup is overridden by the PCID received at session establishment. You should use the PCID received at session establishment when you are using a model network.

NPA specifies whether the network performance analyzer function is to be included in the system generation definition. Refer to Chapter 24 for more information about the network performance analyzer.

SESSACC determines whether NCP is to collect session accounting information for all peripheral function sessions. If you invoke this function, you must also code NPA=YES.



---

## Chapter 15. Internet Resources

An *internet* is a virtual network composed of one or more physical networks, whose nodes communicate with one another using *Internet Protocol (IP)*. The nodes in an internet are called *internet hosts*. Information is transmitted between internet hosts in packets called *IP datagrams*. Some internet hosts serve as *internet routers*, which receive IP datagrams from other internet hosts and forward them toward their destinations. NCP can function as an internet router.

### Notes:

1. To define the NCP internet resources described in this chapter, you should be familiar with your internet configuration and should know the internet address of each internet host. Your LAN administrator can provide this information.
2. The general approach for defining NCP internet resources has changed for NCP V7R1 and later releases. For a detailed description of the process for migrating internet resources from earlier NCP releases to NCP V7R1 or later, see “Migrating Internet Resources to NCP V7R1 and Later Releases” on page 15-57.

*IBM Transmission Control Protocol/Internet Protocol (TCP/IP)* provides a logical connection service between internet hosts and improves the reliability of the Internet Protocol data transfer process. NCP uses IBM TCP/IP to route IP datagrams to other internet hosts through the following connections:

- An SNA session with another NCP or other IBM TCP/IP host
- A *carrier sense multiple access/collision detection (CSMA/CD)* local area network (referred to in this book as an *Ethernet-type LAN*)
- A Token Ring attached to NCP through NCP/Token-Ring interconnection (NTRI)<sup>1</sup>
- A physical connection into a frame-relay network
- An internal NCP to Model 900 point-to-point IP connection
- A 370 I/O channel or ESCON channel connection

To use this chapter, you should be familiar with TCP/IP. For more information about TCP/IP, refer to *Internetworking with TCP/IP Volume I: Principles, Protocols, and Architecture*.

IP datagrams are transported through SNA networks using *NCP connectionless SNA transport (NCST)* sessions. You can define NCST logical units in your NCP to participate in NCST sessions with IBM TCP/IP and its SNALINK application and with NCST logical units in other NCPs. For more information about SNALINK, refer to the documentation listed in “TCP/IP Publications” on page X-38.

NCP can route IP datagrams over Ethernet-type LANs, NTRI-attached Token Rings, frame-relay networks, internal NCP to Model 900 point-to-point IP connections, and channel connections (370 I/O channel or ESCON). For Ethernet-type LAN attachments, NCP uses Ethernet Version 2 and Institute of Electrical and Elec-

---

<sup>1</sup> In this chapter, the term *LAN* refers to both Ethernet-type LANs and NTRI-attached Token Rings unless otherwise specified.

tronic Engineers (IEEE) standard 802.3. NCP can use both standards on a single Ethernet-type subsystem (ESS) physical line. For NTRI attachments, NCP uses IEEE standard 802.5. NCP can route both internet and SNA traffic on a single Token-Ring physical line.

Figure 15-1 shows an NCP with an Ethernet-type LAN attachment, a NTRI attachment, and an NCST logical unit in session with a SNALINK logical unit.

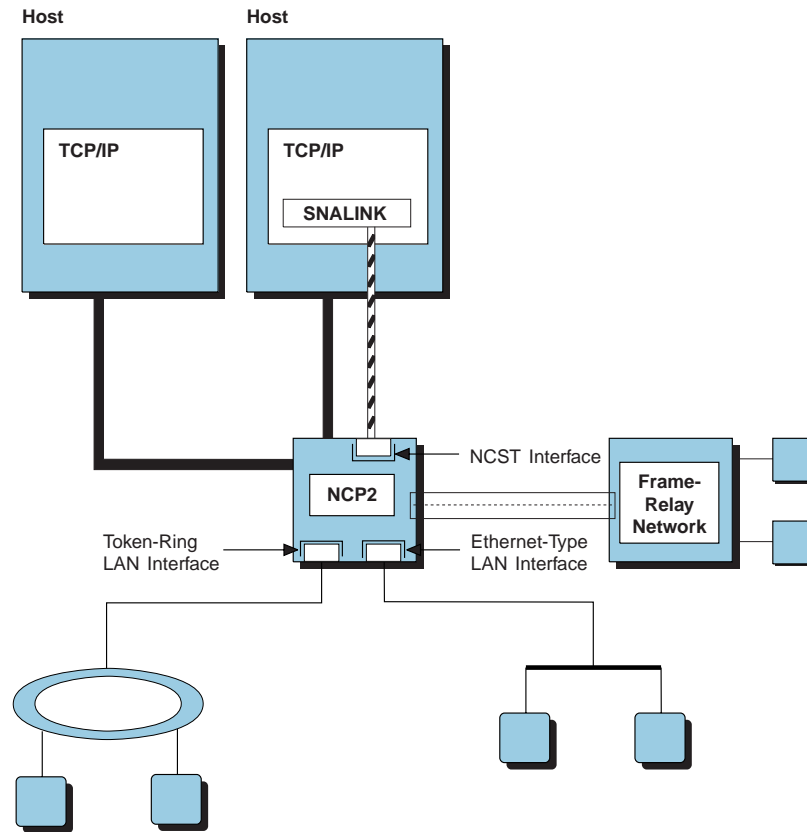

Figure 15-1. NCP with an NCST Session and LAN Attachments

NCST sessions, Ethernet-type LAN attachments, NTRI attachments, frame-relay attachments, internal NCP to Model 900 point-to-point IP connections, and channel attachments for internet are all *NCP internet routing interfaces*. Each interface has its own internet address. For each interface, you can also define internet routing addresses, addresses for internet hosts on a LAN, and subnetwork addresses, all of which enable the interface to route datagrams through the internet.

You can divide an internet network into *subnetworks*. You can then route IP datagrams to specific subnetwork destinations rather than to all destinations in the network, thereby reducing network traffic.

The remainder of this chapter describes the following:

- Definition statements for defining NCP internet resources
- Specifying internet addresses
- Defining NCST session interfaces
- Defining channel attachments
- Defining Ethernet-type LAN attachments
- Defining NTRI attachments

- Defining internal NCP to Model 900 point-to-point IP connections
- Defining frame-relay attachments
- Defining internet routes
- Migrating internet resources to NCP V7R1 and later releases
- Internet performance
- Sample internet resource configurations and definitions.

---

### Definition Statements for NCP Internet Resources

Use the following general approach to define NCP internet resources. Be sure to code the definition statements in the order given here. Read the sections cited here for more information on defining specific resources.

1. Code GROUP, LINE, PU and LU definition statements to define groups of lines to support various internet connections. You can also code IPHOST definition statements to define other internet hosts in your network.
  - If you want an NCST session with the owning TCP/IP host, code a GROUP definition statement with NCST=IP. Also, if you want an NCST session with NCST logical units in other NCPs, code a GROUP definition statement with NCST=IP. Code one or more LU definition statements to define NCST logical units. (See “Defining NCST Session Interfaces” on page 15-8.)
  - If you want to route internet traffic to an Ethernet-type LAN, code a GROUP definition statement with ETHERNET=PHYSICAL to define the connection to the LAN. You can also code one or more IPHOST definition statements in the group to define internet hosts attached to the LAN. (See “Defining Ethernet-Type LAN Attachments” on page 15-25.)
  - If you want to route internet traffic to a NTRI-attached Token Ring, code a GROUP definition statement with ECLTYPE=PHYSICAL to define the physical connection to the Token Ring. You can also code one or more IPHOST definition statements in the physical line group to define internet hosts attached to the Token Ring. (See “Defining NTRI Attachments for IP” on page 15-31.)
  - If you want to route internet traffic between the 3746 Model 900 IP router and NCP’s IP router via an internal NCP to Model 900 point-to-point IP connection, code a GROUP definition statement with ECLTYPE=PHYSICAL. In addition, code a PU statement with PUTYPE=1 and NETWORK=IP beneath a LINE statement that defines an 3746 Model 900-attached Token-Ring physical link. (See “Defining an Internal NCP to Model 900 Point-to-Point IP Connection” on page 15-39.)
  - If you want to route internet traffic to a frame-relay network, code a GROUP definition statement with FRELAY=PHYSICAL to define the physical connections to the frame-relay network. Code INTFACE or LADDR on one or more PU definition statements to define internet hosts attached to the frame-relay network. (See “Defining Frame-Relay Attachments for IP” on page 15-44.)
  - If you want to route internet traffic to a channel-attached host, code a GROUP definition statement with LNCTL=CA to define the physical connections to the channel. Code INTFACE or LADDR on the PU definition statement to define an internet host attached to a channel. (See “Defining 370 I/O Channels for IP” on page 15-18.)

## Specifying Internet Addresses

2. If you want dynamic route management, define the owning IBM TCP/IP host. Code exactly one IPOWNER definition statement to define the owning IBM TCP/IP host. (See “Defining the Owing TCP/IP Host” on page 15-7.) IPOWNER and all subsequent internet definition statements must follow the last GROUP definition statement in your generation definition.
3. Code one or more IPLOCAL definition statements to define NCP internet interfaces to the following:
  - The SNALINK application running in the host, or NCST logical units in other NCPs (see “Defining NCST Session Interfaces” on page 15-8)
  - Ethernet-type LANs (see “Defining Ethernet-Type LAN Attachments” on page 15-25)
  - NTRI-attached Token Rings (see “Defining NTRI Attachments for IP” on page 15-31)
  - Internal NCP to Model 900 point-to-point IP connections (see “Defining an Internal NCP to Model 900 Point-to-Point IP Connection” on page 15-39)
  - Frame-relay networks (see “Defining Frame-Relay Attachments for IP” on page 15-44)
  - Channel interfaces (see “Defining 370 I/O Channels for IP” on page 15-18)

These IPLOCAL definition statements also define internet routes to directly attached logical units, Ethernet-type LANs, Token Rings, frame-relay networks, and channel interfaces. (See “Routes Implicitly Defined by NCP Internet Interfaces” on page 15-53.)

4. If your network supports Routing Information Protocol (RIP), you do not need to explicitly define internet routes to the various destinations in your network; NCP will automatically discover these routes through RIP. (See “Routes Defined by NCPROUTE through RIP” on page 15-53.) However, if your internet network does not support RIP, or if you want internet routes that cannot be changed by RIP, you can code one or more IPROUTE definition statements to define routes explicitly. (See “Defining Routes Explicitly” on page 15-54.)

---

## Specifying Internet Addresses

Internet addresses identify the source and destination of an IP datagram as well as each node in the network that forwards the datagram. This section describes how to specify internet addresses in NCP. For more information about internet addresses in general, refer to *Internetworking with TCP/IP Volume I: Principles, Protocols, and Architecture*.

### Internet Address Formats

Internet addresses are 4 bytes long and can be specified in either of two formats: dotted-decimal or hexadecimal.

- In dotted-decimal format, each byte is specified as a decimal value, and the bytes are separated by periods (for example, 128.81.0.254). This is the more commonly used format.
- In hexadecimal format, the address is specified as a 4-byte hexadecimal number (for example, 805100FE, which is the same value as the preceding dotted-decimal example).

Internet addresses consist of a network address portion followed by a host address portion. The network address portion is assigned by a central network authority to identify the local network within the internet.

### Internet Address Classes

NCP supports three internet address classes. All addresses in an internet must be in the same class. The difference among the classes is in the number of networks and internet hosts that can be defined. In general, the more networks you define, the fewer internet hosts you can define. Choose the address class that best meets the needs of your configuration. Table 15-1 shows the structures of the internet address classes in dotted-decimal format.

Table 15-1. Internet Address Structure

Address Class	Range of First Byte <sup>1</sup>	Address Structure <sup>2</sup>
A	1–126 (X'01'–X'7E')	nnn.hhh.hhh.hhh
B	128–191 (X'80'–X'BF')	nnn.nnn.hhh.hhh
C	192–223 (X'C0'–X'DF')	nnn.nnn.nnn.hhh
D <sup>3</sup>	224–239 (X'E0'–X'EF')	mmm.mmm.mmm.mmm

- <sup>1</sup> The value of the first byte identifies the address class.
- <sup>2</sup> nnn represents 1 byte (in decimal) of the network address.  
 hhh represents 1 byte (in decimal) of the host address.  
 mmm represents 1 byte (in decimal) of the multicast group ID.
- <sup>3</sup> Only the RIP-2 class D address (224.0.0.9) is supported.

### Broadcast Addresses

A broadcast is an IP datagram that is sent to all destinations in the network rather than to a particular destination.

Any address whose host portion is all B'0' or all B'1' is a broadcast address.

### Multicast Addresses

A multicast is a special form of broadcast where the IP datagram is sent to a selected group of destinations.

NCP supports multicasting for RIP Version 2 packets only, and only when multicast support is configured in NCPROUTE. NCP broadcasts RIP-2 multicast packets on NTRI interfaces. RIP-2 multicast packets are multicast on Ethernet interfaces if VSUBNETS=YES; otherwise they are broadcast.

### Specifying Internet Network Addresses

When you specify an internet network address as a keyword value, specify zero for the host address portion. For example, to define the class B network address 128.81 for the DESTADDR keyword, code DESTADDR=128.81.0.0 or DESTADDR=80510000 since the third and fourth bytes of a class B address are the host address portion.

### Specifying Internet Host Addresses

When specifying an internet host address as a keyword value, specify a nonzero value for the host address portion. If you are using subnetworks, specify a nonzero value for the portion of the host address that is not used to identify a subnetwork. The following section describes this in more detail.

### Specifying Internet Subnetwork Addresses

You can divide a single internet network into multiple logical networks called *subnetworks*. Subnetwork addressing can enhance local routing capabilities while reducing the number of internet network addresses required. When you use subnetworks, the host portion of an internet address is divided into a subnetwork address portion and a subnetwork host portion. To designate a subnetwork, specify a non-zero value for the subnetwork address portion.

You identify the subnetwork portion of the host address by defining a *subnetwork mask*. Figure 15-2 shows an example of a subnetwork mask for a Class B network address. In this example, the first 6 bits of the host address portion of the mask are set to 1 to identify the subnetwork portion of the address. The resulting 6-bit subnetwork portion can provide a unique address for 64 ( $2^6$ ) subnetworks.

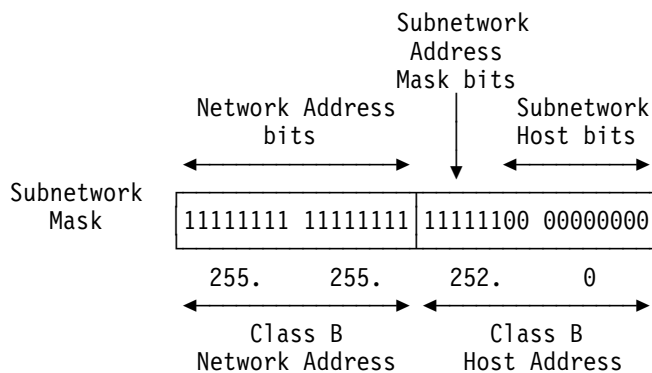

Figure 15-2. Sample Internet Subnetwork Mask

Subnetwork masks are defined by SNETMASK on the IPLOCAL, IPRROUTE, or PU definition statement. The subnetwork mask you define applies to the internet network address defined by LADDR on the same IPLOCAL or PU definition statement, or defined by DESTADDR on the same IPRROUTE definition statement. To define the subnetwork mask in the preceding example, code either SNETMASK=255.255.252.0 or SNETMASK=FFFFC00. NCP supports variable subnetting (more than one subnet mask per network) starting with V7R6.

**Note:** When considering your network design, remember that the host address is affected by the value chosen for a subnetwork mask. If a subnetwork mask causes the host address to contain all zeros or all ones, NCP treats datagrams with this destination address as broadcast datagrams.

For an example showing how to use a subnetwork mask, see "Sample Coding to Define an Internet Route to a Subnetwork" on page 15-56. For more information about internet subnetting in general, refer to *Internetworking with TCP/IP Volume 1: Principles, Protocols, and Architecture*.



## Defining the Owing TCP/IP Host

The owing IBM TCP/IP host provides dynamic updating of NCP internet routes by exchanging routing information with NCP to update the NCP internet route table. If you will use the dynamic route update function, code exactly one IPOWNER definition statement in your generation definition to define the owing IBM TCP/IP host. For more information about dynamic route updating, see “Routes Defined by NCPROUTE through RIP” on page 15-53.

Code the following definition statements and keywords to define the owing IBM TCP/IP host.

IPOWNER	HOSTADDR
	INTERFACE
	MAXHELLO
	NUMROUTE
	UDPPORT

HOSTADDR on the IPOWNER definition statement specifies the internet address of the owing IBM TCP/IP host. The value of HOSTADDR must match the value defined on the HOME statement in the TCP/IP profile data set. The value of HOSTADDR should also match the value of P2PDEST on the IPLOCAL definition statement that defines the interface (either NCST or IP channel) specified by INTERFACE on the IPOWNER definition statement.<sup>2</sup> If backup IP channel interfaces are defined (see “Backup IP Channel Interfaces” on page 15-8), they do not affect HOSTADDR. HOSTADDR only needs to match the P2PDEST on the IPLOCAL definition statement for the **primary** IP channel interface.

INTERFACE identifies the internet router interface over which the owing IBM TCP/IP host is reached. The interface name you specify must identify an NCST session interface or an IP channel interface. You can define backup IP channel interfaces; see “Backup IP Channel Interfaces” on page 15-8.

MAXHELLO specifies how many *hello* datagrams NCP is to send to the owing IBM TCP/IP host without receiving an acknowledgment. NCP sends a hello datagram every 30 seconds. If NCP has not received an acknowledgment after sending this many hello datagrams, NCP issues an alert and pauses for 9 minutes to enable the operator to correct the error, and then begins sending hello datagrams again. MAXHELLO=NONE disables this function and sends hello datagrams every 30 seconds without pause. However, MAXHELLO=NONE is not recommended because no alert will be issued to inform the operator of the problem. In addition, MAXHELLO=NONE is not valid if multiple IP channel interfaces are coded on INTERFACE.

NUMROUTE specifies how many internet routes the owing IBM TCP/IP host can add dynamically to each Internet host, subnetwork, and network beyond the number defined in your generation definition.

<sup>2</sup> This restriction does not apply in the absence of SNALINK, where the remote NCP definition must use an indirect path to NCPROUTE via an NCST connection to a local NCP that has an IP channel connection to the NCPROUTE host.

## Defining NCST Session Interfaces

**Note:** You can cause NCP to dynamically create control blocks for additional internet routes when needed. See “Dynamically Created Control Blocks” on page 2-10 for more information.

UDPPORT specifies the User Datagram Protocol (UDP) port number used by the owning IBM TCP/IP host to communicate with the NCP internet router. This port number must be the same as the port number used by the NCPROUTE server in the owning IBM TCP/IP<sup>3</sup> host, as specified by NCPROUTE on the HOME statement in the TCP/IP profile data set. The default port number is 580.

### Backup IP Channel Interfaces

The INTFACE keyword of the IPOWNER statement can list multiple interfaces if they are all IP channel interfaces. The first interface listed will be the primary interface used to route UDP datagrams to the owning IBM TCP/IP host. All other interfaces listed will be used as backup interfaces.

---

## Defining NCST Session Interfaces

You can route IP datagrams through an SNA network by defining LU-LU sessions. These sessions are defined when you define NCP connectionless SNA transport (NCST) sessions. A single NCST interface can have multiple logical units defined; if this is the case, the first one defined is the primary LU-LU session partner and the others are backups. An NCST link needs to be defined on both sides of the session for successful routing of IP datagrams. In Figure 15-4 on page 15-13, the SNALINK application (H1APPL) provides this function in the IBM 370 host.

**Note:** NCP does not support internet broadcasts for point-to-point connections. NCP NCST connections are point to point, so they do not support broadcasts.

Code the following definition statements and keywords to define the NCST sessions and interfaces.

GROUP	NCST
LINE	
PU	VPACING
LU	INTFACE REMLU
IPLOCAL	INTFACE LADDR METRIC P2PDEST PROTOCOL SNETMASK

---

<sup>3</sup> For information on which IBM TCP/IP product releases and operating systems support NCPROUTE, refer to the TCP/IP documentation for your host operating system.

### GROUP

NCST on the GROUP definition statement defines a line group for an NCST routing interface that supports Internet Protocol. Code NCST=IP to define this NCST routing interface. You can code only one GROUP definition statement with NCST=IP in your generation definition, and you can code only one LINE definition statement in that group.

### PU

VPACING on the PU definition statement is a VTAM-only keyword that defines the send pacing window to be used in the primary to secondary direction on any NCST sessions defined on this PU definition statement. For NCST-NCST sessions, code VPACING=0 to maximize throughput over the virtual route.

### LU

The LU definition statement defines an NCST logical unit in NCP and identifies the remote logical unit partner with which an LU-LU NCST session can be established. Code the label for the LU definition statement as follows:

- For an NCST-SNALINK session, the name of the LU definition statement must match the SNALINK logical unit name defined on the DEVICE statement in the TCP/IP profile data set.
- For an NCST-NCST session, the name of the LU definition statement must match the VALUE of REMLU on the LU definition statement that defines the logical unit partner in the remote NCP.

INTERFACE on the LU definition statement assigns a name to the NCST logical unit. This name is used to associate the NCST logical unit with a particular NCST interface. To make this association, specify the same name for the following keywords:

- INTERFACE on the LU definition statement that defines the NCST logical unit
- INTERFACE on the IPLOCAL definition statement that defines the NCST interface.

INTERFACE also establishes the maximum transfer unit (MTU) for the session, which is the maximum size of the IP datagrams to be routed by this session. Take the following performance issues into consideration when you define the MTU size:

- The maximum inbound PIU size (BFRS on the BUILD definition statement times TRANSFR on the BUILD, LINE, or PU definition statement) must be greater than or equal to the value of MAXRU in the SNALINK start procedure.
- The maximum outbound PIU size (MAXBFRU on the PU definition statement times UNITSZ on the VTAM HOST definition statement) must be greater than or equal to the MTU. This PIU size must match VTAM IOBUF values.
- The owning IBM TCP/IP host bundles datagrams into packets to be sent over the same interface. NCP unbundles the datagrams for further routing. The maximum packet size is 32KB. Any TCP/IP packets or individual datagrams larger than the SNALINK MAXRU value will cause PIUs to be chained to NCP, which can degrade performance.
- The MTU plus 29 bytes should be less than or equal to the maximum data transfer size defined for the channel. If it is not, an exception request with sense code X'800A' is generated when data larger than the maximum data transfer size is sent across the channel.
- The MTU must be the same for primary and backup sessions.

## Defining NCST Session Interfaces

You can define more than one logical unit with the same INTFACE name. The first logical unit defined is used as the primary LU-LU session and all others serve as backups. Backup NCST sessions are used when:

- The primary session fails.
- NCP enters pseudo-slowdown and the size of the primary session queue exceeds the queue size limit (CNLSQMAX on the BUILD definition statement).

REMLU specifies the name of the logical unit partner for the NCST logical unit. Specify the value of REMLU as follows:

- For an NCST-SNALINK session, REMLU must match (1) the name of the VTAM APPL definition statement in the major node definition, and (2) the name specified by ACBNAME on that APPL definition statement.
- For an NCST-NCST session, REMLU must specify the name of the LU definition statement that defines the logical unit partner in the remote NCP.

Note the following:

- If you are defining a primary NCST-NCST or NCST-SNALINK session, REMLU must specify the name of the logical unit partner.
- If you are defining a backup NCST-NCST session, REMLU cannot specify the name of the primary logical unit partner.
- If you are defining a backup NCST-SNALINK session, REMLU can specify the name of the primary logical unit partner or a different partner.

You can also use the REMLU keyword to specify the name of the VTAM logmode table entry to use and to indicate that the remote logical unit is always to be the secondary logical unit.

## IPLOCAL

The IPLOCAL definition statement defines characteristics of the NCST session interface to the NCP internet router, and also implicitly defines a route to the NCST session partner. (For more information on implicitly defined routes, see “Routes Implicitly Defined by NCP Internet Interfaces” on page 15-53.) Code an IPLOCAL definition statement, including the INTFACE keyword, for each NCST session interface.

INTFACE on the IPLOCAL definition statement assigns a name to the NCST interface. This name is used to associate the NCST interface with a particular NCP NCST logical unit. To make this association, specify the same name for the following keywords:

- INTFACE on the LU definition statement that defines the NCST logical unit
- INTFACE on the IPLOCAL definition statement that defines the NCST interface.

INTFACE is required. The value of INTFACE on each IPLOCAL definition statement in your generation definition must be unique.

LADDR defines the internet address for the internet router interface. This address is used by all other nodes in the network to refer to this interface. The value of LADDR must be a valid address in the network or subnetwork to which this interface is attached. LADDR is required. The value of LADDR on each IPLOCAL definition statement in your generation definition must be unique.

METRIC assigns a metric (a value from 1 to 15) to the interface. NCP and TCP/IP use the metric to determine the best route to a destination. For more information,

see the description of METRIC on the IPRROUTE definition statement on page 15-55.

P2PDEST specifies the internet address of the session partner for a point-to-point connection. (NCST connections are point to point.) For an NCST connection, specify the internet address of the NCST session partner in the host or remote NCP.

For an NCST session to the owning IBM TCP/IP host (that is, when the name specified by INTFACE on the IPLOCAL definition statement is the same as the name specified by INTFACE on the IPOWNER definition statement), the address specified by P2PDEST should be the same as the address specified by HOSTADDR on the IPOWNER definition statement.<sup>4</sup>

PROTOCOL specifies whether this interface is to be managed by NCPROUTE in the owning IBM TCP/IP host through RIP. If you code PROTOCOL=NONE, the interface is not defined to NCPROUTE, and NCP does not broadcast RIP information about NCP internet routes through this interface. This enables you to define interfaces that are managed through protocols other than RIP. For more information on NCPROUTE, refer to *NCP and EP Reference*.

SNETMASK defines a mask that identifies the subnetwork address portion of the internet host address. The subnetwork mask determines which portion of the internet address, defined by the LADDR keyword, identifies the subnetwork. For more information, see “Specifying Internet Subnetwork Addresses” on page 15-6.

### NDF-Added Keywords for NCST Interfaces

When you code NCST=IP on the GROUP definition statement to define an NCST interface, NDF adds the following keywords to your generation definition if you do not code them.

```

GROUP LNCTL=SDLC,
      VIRTUAL=YES
LINE  LINECB=CXSXLNK,
      LINEFVT=CXSXFVT,
      LUFVT=(CXSXFVT,CXSXFVT),
      PUFVT=CXSXFVT
PU    PUCB=CXSP1111, 1
      PUTYPE=2
LU    LOCADDR=mmm, 2
      LUCB=(CXSLnnnn,CXSSnnnn) 2

```

<sup>1</sup> 1111 is a counter that is incremented for each physical unit.  
<sup>2</sup> mmm and nnnn are counters that are incremented for each logical unit.

Figure 15-3. NDF-Added Keywords for NCST Interfaces

<sup>4</sup> This restriction does not apply in the absence of SNALINK, where the remote NCP definition must use an indirect path to NCPROUTE via an NCST connection to a local NCP that has an IP channel connection to the NCPROUTE host.

### Establishing NCST Sessions

An NCST logical unit can establish a session with another NCST logical unit or SNALINK logical unit. When the NCST-NCST session is established, the BIND is sent by the primary logical unit.

You can code a logmode table entry on the REMLU keyword on the NCST LU definition statement. This REMLU table entry must also be entered in the VTAM logmode table; however, the entry will not appear in the DLOGMOD field when you display the logical unit from VTAM. If you omit the logmode table entry on the REMLU keyword, the NCST logical unit uses default values.

When an NCST-SNALINK session is established, code the VTAM DLOGMOD keyword on the LU definition statement instead of coding a logmode table entry on the REMLU keyword. If the NCST logical unit is secondary, code DLOGMOD on the LU definition statement. If the SNALINK logical unit is secondary, code DLOGMOD in the VTAM application major node for the SNALINK logical unit. If no logmode table entry is coded, the NCST logical unit and SNALINK logical unit use default values.

Information about coding VTAM keywords can be found in *VTAM Resource Definition Reference* and *VTAM Customization*. Consult *NCP and EP Reference* for information about the BIND and how the NCST logical unit uses logmode table default entries. See *TCP/IP Installation and Maintenance* for information about SNALINK.

If you define an NCST interface with a primary logical unit and a backup logical unit, Internet Control Message Protocol (ICMP) echo messages are supported only on the primary logical unit defined for that interface. The secondary NCST logical unit can participate in concurrent LU-LU sessions with other partners but will not respond to an ICMP echo message from a connected host.

### Sample Coding to Define NCST Interfaces and Logical Units

Figure 15-4 on page 15-13 shows NCST interfaces and logical units in two NCPs, NCP1 and NCP2. In this configuration, these interfaces and logical units provide the following LU-LU sessions:

- Logical unit A03NCSA7 in NCP1 provides an LU-LU session with SNALA17, the SNALINK application in NCP1's owning IBM TCP/IP host. NCP1's NCST interface for this session is called IPOWNER.
- Logical unit B31NCSB1 in NCP2 provides an LU-LU session with SNALB01, the SNALINK application in NCP2's owning IBM TCP/IP host. NCP2's NCST interface for this session is called IPOWNER.
- Logical unit A03NCS1P in NCP1 provides a primary LU-LU session with B31NCS1P in NCP2, and A03NCS1B in NCP1 provides a backup session with B31NCS1B in NCP2. NCP1's NCST interface for these sessions is called INTF2, and NCP2's NCST interface for these sessions is called INTF1.

This configuration is a subset of the network configuration shown in Figure 15-18 on page 15-61.

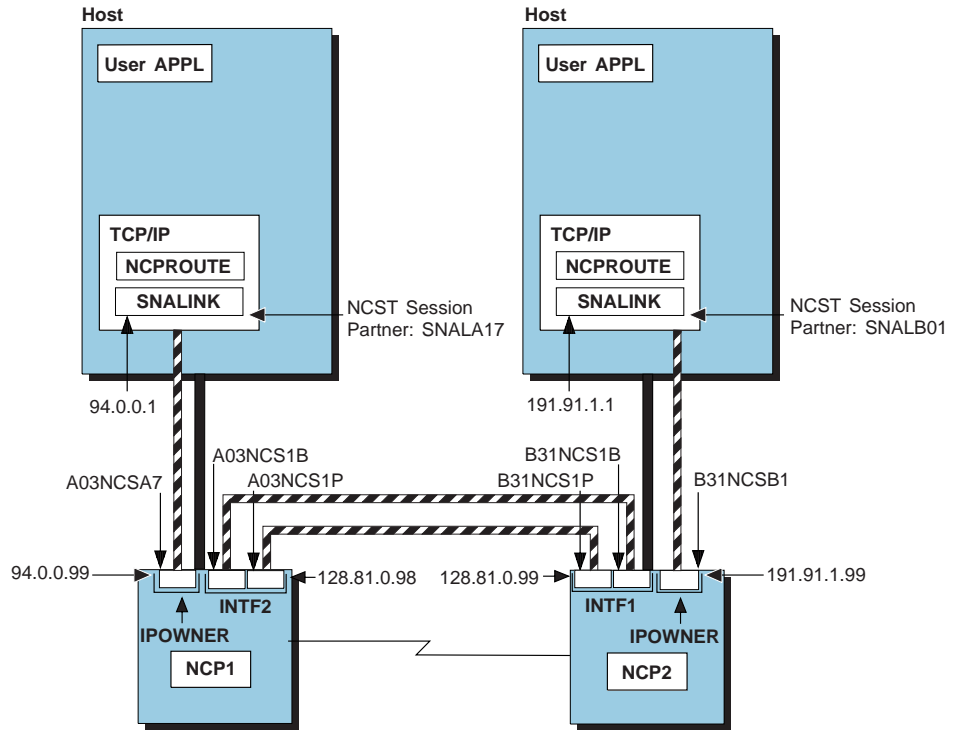

Figure 15-4. NCST Interfaces and LU-LU Sessions

Figure 15-5 on page 15-14 shows how to define the NCST interfaces and LU-LU sessions shown in Figure 15-4. Notice that Figure 15-5 on page 15-14 shows portions of two separate generation definitions, one for NCP1 and one for NCP2.

## Defining NCST Session Interfaces

```

*****
*                               NCP1                               *
*****
*   NCST IP INTERFACES                                           *
*****
*
A03NCSTG GROUP NCST=IP,           Line group for internet router LUs*
                LNCTL=SDLC,           *
                ANS=CONT,             *
                ISTATUS=ACTIVE       VTAM-only keyword
A03NCSTL LINE
A03NCSTP PU
*****
A03NCSA7 LU   INTERFACE=IPOWER,    IPOWER is routing interface to A17*
              REMLU=SNALA17        SNALA17 is the remote LU name
*****
A03NCS1P LU   INTERFACE=INTF2,     INTF2 is routing interface to B31 *
              REMLU=(B31NCS1P)     B31NCS1P is the remote primary LU
A03NCS1B LU   INTERFACE=INTF2,     INTF2 is routing interface to B31 *
              REMLU=(B31NCS1B)     B31NCS1B is the remote backup LU
*****
A03NCSA1 LU   INTERFACE=HOSTA01,   HOSTA01 is routing interface to A01*
              REMLU=SNALA01        SNALA01 is the remote LU name
*
*                               Channel adapter, non-native
*                               network, and path definitions
*
*****
*   IP ROUTING DEFINITIONS                                       *
*****
*
*   IP OWNER IDENTIFICATION
*
*       IPOWER INTERFACE=IPOWER,   IPOWER is interface to owning host*
*       HOSTADDR=94.0.0.1,        94.0.0.1 is the host's IP address *
*       NUMROUTE=(25,25,25)      Maximum number of dynamically added
*                               routes per host/subnet/network
*
*   IP ADDRESSES ASSIGNED TO LOCAL NCP INTERFACES
*
*       NCST INTERFACES
*
*       IPLOCAL LADDR=94.0.0.99,   94.0.0.99 is the IP address *
*       INTERFACE=IPOWER,         IPOWER is the interface name *
*       METRIC=1,                 Standard hop in an internet route *
*       P2PDEST=94.0.0.1,        94.0.0.1 SNALINK's IP addr in host *
*       PROTOCOL=RIP              The default is RIP
*       IPLOCAL LADDR=95.0.0.99,   95.0.0.99 is the IP address *
*       INTERFACE=HOSTA01,        HOSTA01 is the interface name *
*       METRIC=1,                 Standard hop in an internet route *
*       P2PDEST=95.0.0.1,        95.0.0.1 SNALINK's IP addr in host *
*       PROTOCOL=RIP              The default is RIP
*       IPLOCAL LADDR=128.81.0.98, 128.81.0.98 is the IP address *
*       INTERFACE=INTF2,         INTF2 is the interface name *
*       METRIC=1,                 Standard hop in an internet route *
*       P2PDEST=128.81.0.99,     128.81.0.99 IP addr in other NCP *
*       PROTOCOL=RIP              The default is RIP
*

```

Figure 15-5 (Part 1 of 5). Example: Defining NCST Interfaces and LU-LU Sessions



```

*****
*                               NCP2                               *
*****
*   NCST INTERFACES                                               *
*****
*
B31NCSTG GROUP NCST=IP,           Line group for internet router LUsX
                LNCTL=SDLC,             X
                ANS=CONT,               X
                ISTATUS=ACTIVE         VTAM-only keyword

*
B31NCSTL LINE
*
B31NCSTP PU
*
*****
B31NCSB1 LU    INTERFACE=IPOWER,     IPOWER is routing interface to B0IX
                REMLU=SNALB01        SNALB01 is the remote LU name
*****
B31NCS1P LU    INTERFACE=INTF1,      INTF1 is routing interface to A03 X
                REMLU=(A03NCS1P)     A03NCS1P is the remote primary LU
B31NCS1B LU    INTERFACE=INTF1,      INTF1 is routing interface to A03 X
                REMLU=(A03NCS1B)     A03NCS1B is the remote backup LU
*****
B31NCS1C1 LU   INTERFACE=HOSTC01,    HOSTC01 is routing interface to C0IX
                REMLU=SNALC01        SNALC01 is the remote LU name
*
                .                   Channel adapter, non-native
                .                   network, and path definitions
                .
*****
*   IP ROUTING DEFINITIONS                                       *
*****
*
*   IP OWNER IDENTIFICATION
*
                IPOWER INTERFACE=IPOWER, IPOWER is interface to owning hostX
                HOSTADDR=191.91.1.1, 191.91.1.1 is the host's IP addressX
                NUMROUTE=(25,25,25) Maximum number of dynamically added
                routes per host/subnet/network
*
*
*   IP ADDRESSES ASSIGNED TO LOCAL NCP INTERFACES
*
                NCST INTERFACES
*
                IPLOCAL LADDR=191.91.1.99, 191.91.1.99 is the IP address X
                INTERFACE=IPOWER, IPOWER is the interface name X
                METRIC=1,           Standard hop in an internet route X
                P2PDEST=191.91.1.1, 191.91.1.1 SNALINK's IP addr n hostX
                PROTOCOL=RIP        The default is RIP
                IPLOCAL LADDR=201.74.19.99, 201.74.19.99 is the IP address X
                INTERFACE=HOSTC01,  HOSTC01 is the interface name X
                METRIC=1,           Standard hop in an internet route X
                P2PDEST=201.74.19.1, 201.74.19.1 SNALINK's IP addr host X
                PROTOCOL=RIP        The default is RIP
                IPLOCAL LADDR=128.81.0.99, 128.81.0.99 is the IP address X
                INTERFACE=INTF1,    INTF1 is the interface name X
                METRIC=1,           Standard hop in an internet route X
                P2PDEST=128.81.0.98, 128.81.0.98 IP addr in other NCP X
                PROTOCOL=RIP        The default is RIP

```

Figure 15-5 (Part 2 of 5). Example: Defining NCST Interfaces and LU-LU Sessions

## Defining NCST Session Interfaces

```

*****
***** B31NCP - NCP FOR SAMPLES NETWORK SUBAREA = 31 *****
*****
          .
          .
          .
*****
*      NCP TOKEN-RING INTERCONNECT PHYSICAL LINES      *
*****
*
B31NTRI  GROUP ADAPTER=TIC2,                               *
            ANS=CONTINUE,                                   *
            ECLTYPE=(PHYSICAL,ANY),                       *
            MAXTSL=4060,                                   *
            RCVBUFC=32000,                                 *
            RETRIES=(20,5,5),                             *
            USSTAB=AUSSTAB,                               *
            XID=NO,                                       *
            TYPE=NCP,                                     *
            DIAL=NO,                                       *
            LNCTL=SDLC,                                   *
            LEVEL2=ECLNARL2,                             *
            LEVEL3=ECLNARL3,                             *
            LEVEL5=NCP,                                   *
            TIMER=(ECLNART1,,ECLNART2,ECLNART3),         *
            XIO=(ECLNARXL,ECLNARXS,ECLNARXI,ECLNARXK),   *
            USERID=(5668854,ECLRBDT,NORECMS,,ECLNMVT),   *
            SPEED=9600,                                   *
            NPACOLL=NO,                                   *
            PUTYPE=1,                                     *
            PUDR=NO,                                      *
            COMPTAD=YES,                                  *
            COMPSWP=YES,                                  *
            COMPOWN=YES
*
*****
*      ADDRESS 1092:  NTRI PHYSICAL LINE                  *
*****
B31TR92  LINE ADDRESS=(1092,FULL),                         *
            INTFACE=TR92,                                 *
            LOCADD=400000017335,                         *
            PORTADD=5,                                   *
            TRSPEED=4,                                   *
            UACB=(X$P1AX,X$P1AR)
*
*      PU FOR SNA TRAFFIC
*
B31PU92  PU ADDR=01,                                     *
            NETWORK=SNA,                                 *
            PUTYPE=1,                                    *
            INNPORT=YES
*
*      PU FOR IP TRAFFIC
*
B31PU92A PU ADDR=02,                                     *
            ARPTAB=(1000,20,NOTCANON),                  *
            NETWORK=IP,                                  *
            PUTYPE=1,                                    *
            INNPORT=YES
          .
          .
          .

```

Figure 15-5 (Part 3 of 5). Example: Defining NCST Interfaces and LU-LU Sessions

```

*****
*   ETHERNET ADAPTER INTERFACES   *
*****
*
B31ETHG  GROUP DIAL=NO,                *
          ETHERNET=PHYSICAL,          *
          ISTATUS=ACTIVE,             *
          LNCTL=SDLC,                 *
          VIRTUAL=NO
*****
*
B31E170  LINE ADDRESS=(1070,FULL),     *
          FRAMECNT=(100000,5000),     *
          INTFACE=ETH1,               *
          LANTYPE=DYNAMIC,            *
          ANS=CONT
*
B31P170  PU ANS=CONT,                 *
          ARPTAB=(2000,20),           *
          INNPORT=YES,                *
          PUTYPE=1,                   *
          NPACOLL=NO,                 *
          LPDA=BLOCK
*
*****
*
B31E171  LINE ADDRESS=(1071,FULL),     *
          ANS=CONT,                   *
          FRAMECNT=(100000,5000),     *
          INTFACE=ETH3,               *
          LANTYPE=DYNAMIC
*
B31P171  PU ANS=CONT,                 *
          ARPTAB=(2000,20),           *
          INNPORT=YES,                *
          PUTYPE=1,                   *
          NPACOLL=NO,                 *
          LPDA=BLOCK
*
*****
*   NCST INTERFACES               *
*****
*
B31NCSTG GROUP NCST=IP,LNCTL=SDLC,ANS=CONT,ISTATUS=ACTIVE, *
          VIRTUAL=YES
*
B31NCSTL LINE LINEFVT=CXSXFVT,        *
          PUFVT=CXSXFVT,              *
          LUFVT=(CXSXFVT,CXSXFVT),    *
          LINECB=CXSXLNK
*
B31NCSTP PU PUTYPE=2,                 *
          PUCB=CXSP0000
*
*****
B31NC SB1 LU INTFACE=IPOWER,REMLU=SNALB01, * TO B01 *
          LUCB=(CXSL0000,CXSS0000),     *
          LOCADDR=1
*****

```

Figure 15-5 (Part 4 of 5). Example: Defining NCST Interfaces and LU-LU Sessions

## Defining 370 I/O Channels for IP

```
B31NCS1P LU INTERFACE=INTF1,REMLU=(A03NCS1P),          * TO A03 *
              LUCB=(CXSL0001,CXSS0001),                *
              LOCADDR=2
B31NCS1B LU INTERFACE=INTF1,REMLU=(A03NCS1B),          * TO A03 *
              LUCB=(CXSL0002,CXSS0002),                *
              LOCADDR=3
*****
B31NCS1C LU INTERFACE=HOSTC01,REMLU=SNALC01,          * TO C01 *
              LUCB=(CXSL0003,CXSS0003),                *
              LOCADDR=4
.
.
.
*****
*   IP ROUTING DEFINITIONS                               *
*****
*
*   IP OWNER IDENTIFICATION
*
      IPOWNER INTERFACE=IPOWNER,HOSTADDR=191.91.1.1,    *
      NUMROUTE=(25,25,25)
*
*   IP ADDRESSES ASSIGNED TO LOCAL NCP INTERFACES
*
*
*       NCST INTERFACES
*
      IPLOCAL LADDR=191.91.1.99,INTERFACE=IPOWNER,METRIC=1, *
      P2PDEST=191.91.1.1,PROTOCOL=RIP
      IPLOCAL LADDR=201.74.19.99,INTERFACE=HOSTC01,METRIC=1, *
      P2PDEST=201.74.19.1,PROTOCOL=RIP
      IPLOCAL LADDR=128.81.0.99,INTERFACE=INTF1,METRIC=1,  *
      P2PDEST=128.81.0.98,PROTOCOL=RIP
*
*       TOKEN RING INTERFACES
*
      IPLOCAL LADDR=128.81.0.95,INTERFACE=TR92,METRIC=1,PROTOCOL=RIP
*
*       ETHERNET INTERFACE CHARACTERISTICS
*
      IPLOCAL LADDR=191.91.2.99,INTERFACE=ETH1,METRIC=1,PROTOCOL=RIP
      IPLOCAL LADDR=128.81.0.97,INTERFACE=ETH3,METRIC=1,PROTOCOL=RIP
*
```

Figure 15-5 (Part 5 of 5). Example: Defining NCST Interfaces and LU-LU Sessions

## Defining 370 I/O Channels for IP

NCP can use a channel interface as an internet transmission medium. The NCP internet router forwards IP and UDP datagrams through channel adapters to hosts or routers attached to the channel. NCP can use a channel as a direct transmission medium, without using NCST sessions. The NCP internal router forwards IP and UDP datagrams to the channel interface.

Code the following definition statements and keywords to define 370 I/O channels for IP.

GROUP	LNCTL
LINE	ADDRESS CA CASDL DELAY DYNADMP HICHAN INBFERS LOCHAN NCPCA TIMEOUT TRANSFR
PU	ANS INTERFACE MAXBFRU PUTYPE
IPLOCAL	INTERFACE LADDR <sup>2</sup> P2PDEST <sup>2</sup> SNETMASK <sup>2</sup>

<sup>2</sup>LADDR, P2PDEST, and SNETMASK can also be coded on the PU definition statement if the channel is not used for direct communication with NCPROUTE.

## GROUP

LNCTL on the GROUP definition statement specifies the type of line control used for the lines in this group. Code LNCTL=CA to define a group of channel links. GROUP definition statements for channel links must follow all GROUP definition statements for SDLC lines in the generation definition. See *NCP, SSP, and EP Resource Definition Reference* for further details.

## LINE

ADDRESS on the LINE definition statement specifies the logical or physical address of the channel adapter in the communication controller.

CA specifies the type of channel adapter attached to the communication controller. You can define either a type 6 or a type 7 channel adapter. The following rules apply to the definition of channel adapters:

- Code CA=TYPE7 to define a type 7 channel adapter in buffer-chaining mode.
- Code CA=TYPE7-TPS to define a type 7 channel adapter in buffer-chaining mode with a two-processor switch.
- Code CA=TYPE6 to define a type 6 channel adapter.
- Code CA=TYPE6-TPS to define a type 6 channel adapter with a two-processor switch.

You can use a type 7 channel adapter in compatibility mode by defining it to NCP as a type 6 channel adapter. Compatibility mode causes a type 7 channel adapter to interface with NCP as a type 6 channel adapter without emulation subchannel

## Defining 370 I/O Channels for IP

(ESC) support because type 7 channel adapters do not support ESC. If you code CA=TYPE7 or CA=TYPE7-TPS for both type 6 and type 7 channel adapters, NCP automatically selects the correct operation mode for each type of adapter.

When you use a type 7 channel adapter, do not code the DYNADMP, HICHAN, or LOCHAN keyword on the LINE definition statement. When you code CA=TYPE7 or CA=TYPE7-TPS, NCP ignores the INBFRS keyword on the LINE definition statement.

CASDL (CA slowdown limit) defines the maximum amount of time the peripheral channel link can block inbound data before signaling that the station is inoperative.

DELAY defines the maximum amount of time NCP is to wait between the time data is available for the host and the time the attention signal is sent over the peripheral channel link to a peripheral host node.

DYNADMP specifies whether you want to include the dynamic dump facility in NCP. If you include this facility, DYNADMP also specifies the address of the emulation subchannel in the channel adapter over which dynamic dump data can be sent to the host processor.

HICHAN defines either the highest subchannel address on the channel adapter associated with any line operating in emulation mode or the address of the subchannel used for dynamic dump data transfer.

INBFRS specifies the default number of controller buffers initially allocated for the first data transfer received from the host processor. The number of controller buffers subsequently allocated dynamically depends on the amount of data received.

LOCHAN defines the lowest subchannel address on the channel adapter associated with any line operating in emulation mode.

NCPCA determines whether the channel is to be enabled for use in network control mode. When a channel adapter is disabled, it is available only for emulation subchannel use. Any type 6 channel adapter not connected to an operational host processor must be disabled.

TIMEOUT specifies the amount of time NCP waits for a response to an attention signal it sent to the host. When the timeout interval expires, NCP initiates channel discontact.

TRANSFR defines the maximum number of buffers that are available to NCP for a single data transfer operation from a channel link. If the value coded on TRANSFR is greater than the largest frame to be received by NCP, buffer storage and NCP cycles are wasted.

## PU

ANS on the PU definition statement specifies whether the link station is to continue operation when NCP enters automatic network shutdown (ANS). ANS=CONTINUE causes NCP to continue to service the link station when automatic network shutdown is initiated.

INTERFACE on the PU assigns a name to the internet interface. The attachment name is used to associate the attachment with a particular direct channel internet

interface. To make this association, specify the same name for the following keywords:

- INTERFACE on the PU definition statement that defines the internet interface for the direct channel attachment
- INTERFACE on the IPLOCAL definition statement that specifies to the direct channel attachment the name of the internet interface for which the local internet address is being defined.

MAXBFRU defines the maximum number of buffer units the access method allocates to receive data from NCP.

PUTYPE defines the type of physical unit associated with the channel link.

PUTYPE=1 defines a channel connection to an internet host.

### IPLOCAL

INTERFACE on the IPLOCAL definition statement assigns a name to the internet interface. This name is used to associate the interface with a particular channel. To make this association, specify the same name for the following keywords:

- INTERFACE on the PU definition statement that defines the internet interface to the channel.
- INTERFACE on the IPLOCAL definition statement that defines the attachment to the channel.

INTERFACE is required. The value of INTERFACE on each IPLOCAL definition statement in your generation definition must be unique.

LADDR defines the internet address for the internet router interface. This address is used by all other nodes in the network to refer to this interface. The value of LADDR must be a valid address in the network or subnetwork to which this interface is attached. LADDR is required. The value of LADDR on each IPLOCAL definition statement in your generation must be unique.

P2PDEST specifies the host address of the destination internet host partner for this direct channel internet connection.

For a channel connection to the owning IBM TCP/IP host, the address specified by P2PDEST should be the same as the address specified by HOSTADDR on the IPOWNER definition statement.<sup>5</sup> In the case where backup IP channel interfaces are defined (see “Backup IP Channel Interfaces” on page 15-8), this paragraph applies only to the IPLOCAL statement for the primary IP channel interface.

SNETMASK defines a mask that identifies the subnetwork address portion of the internet host address. The subnetwork mask determines which portion of the internet address, defined by the LADDR keyword, identifies the subnetwork. For more information, see “Specifying Internet Subnetwork Addresses” on page 15-6.

---

<sup>5</sup> This restriction does not apply in the absence of SNALINK, where the remote NCP definition must use an indirect path to NCPROUTE via an NCST connection to a local NCP that has an IP channel connection to the NCPROUTE host.

## Defining ESCON Channels for IP

### Optional Interface Definition for 370 I/O Channel Resources

For 370 I/O channel internet resources, there are two methods of defining internet interfaces.

- The first method is to code an IPLOCAL definition statement and its associated keywords. This method is also supported for NCST, frame relay, ESCON channels, Ethernet, and Token Ring.
- The second method is to define the necessary interface definition keywords on the PU statement (for example, LADDR and P2PDEST). The IPLOCAL statement must be omitted when using this option. In addition, this option is not available if a channel is used for direct communication with NCPROUTE.

---

## Defining ESCON Channels for IP

NCP can use a channel interface as an internet transmission medium. The NCP internet router forwards IP and UDP datagrams through channel adapters to hosts or routers attached to the channel. NCP can use a channel as a direct transmission medium, without using NCST sessions. The NCP internal router forwards IP and UDP datagrams to the channel interface.

Code the following definition statements and keywords to define ESCON channels for IP (logical connection).

GROUP	LNCTL PHYSRSC
LINE	ADDRESS HOSTLINK SPEED
PU	ADDR ANS CASDL DELAY INTERFACE MAXBFRU PUTYPE TIMEOUT TRANSFR
IPLOCAL	INTERFACE LADDR <sup>2</sup> P2PDEST <sup>2</sup> SNETMASK <sup>2</sup>

<sup>2</sup>LADDR, P2PDEST, and SNETMASK can also be coded on the PU definition statement if the channel is not used for direct communication with NCPROUTE.

### GROUP

LNCTL on the GROUP definition statement identifies the type of line control used for all lines in the group. Code LNCTL=CA to define an ESCON logical line.



PHYSRSC associates the logical line definitions with the corresponding ESCON physical line definition. Make sure the keyword value for PHYSRSC matches the label coded on the PU definition statement that defines the ESCON physical line.

### LINE

ADDRESS on the LINE definition statement specifies the relative line number of the physical line. Do not assign an address to an ESCON logical line. Omit the ADDRESS keyword or code ADDRESS=NONE.

HOSTLINK assigns a logical line number to an ESCON logical line. Assign logical line numbers in sequential order from 1 to 32. The number you assign associates the logical line with attributes defined using MOSS-E. See "Using MOSS Extended to Configure ESCON Links" on page 4-22 for more information.

SPEED sets an estimated data transmission rate to be used by NPM to compute line utilization statistics.

### PU

ADDR on the PU definition statement identifies the ESCON device address to the host node on the logical line. The number you code must correspond to the UNITADD value specified in the host IODEVICE definition statement and to the physical unit address defined to MOSS-E. All the ADDR values for a logical line must be unique. Valid ADDR values range from X'01' to X'20'. See "Using MOSS Extended to Configure ESCON Links" on page 4-22 for more information.

ANS specifies whether the ESCON link is to continue operation when NCP enters automatic network shutdown (ANS). Code ANS=CONTINUE to cause NCP to continue to service the ESCON link when automatic network shutdown is initiated.

CASDL defines the maximum amount of time the ESCON station can block inbound traffic due to slowdown before signaling that the station is inoperative.

DELAY specifies the maximum amount of time NCP is to wait between the time data is available to the host and the time the attention signal is presented by an ESCON station to a host node.

INTERFACE on the PU assigns a name to the internet interface. The attachment name is used to associate the attachment with a particular direct channel internet interface. To make this association, specify the same name for the following keywords:

- INTERFACE on the PU definition statement that defines the internet interface for the direct channel attachment
- INTERFACE on the IPLOCAL definition statement that specifies to the direct channel attachment the name of the internet interface for which the local internet address is being defined.

MAXBFRU identifies the maximum number of buffer units the access method allocates to receive data from NCP.

PUTYPE defines the type of physical unit associated with the channel link. PUTYPE=1 defines a channel connection to an internet host.

TIMEOUT specifies the amount of time NCP is to wait for a response to an attention signal sent to the host before NCP initiates channel discontact.

## Defining ESCON Channels for IP

TRANSFR limits the length of the PIU accepted from a logical line during one data transfer. The value you code should not be greater than the amount of data the access method in the destination host processor accepts in a single channel operation.

### IPLOCAL

INTERFACE on the IPLOCAL definition statement assigns a name to the internet interface. This name is used to associate the interface with a particular channel. To make this association, specify the same name for the following keywords:

- INTERFACE on the PU definition statement that defines the internet interface to the channel.
- INTERFACE on the IPLOCAL definition statement that defines the attachment to the channel.

INTERFACE is required. The value of INTERFACE on each IPLOCAL definition statement in your generation definition must be unique.

LADDR defines the internet address for the internet router interface. This address is used by all other nodes in the network to refer to this interface. The value of LADDR must be a valid address in the network or subnetwork to which this interface is attached. LADDR is required. The value of LADDR on each IPLOCAL definition statement in your generation must be unique.

P2PDEST specifies the host address of the destination internet host partner for this direct channel internet connection.

For a channel connection to the owning IBM TCP/IP host, the address specified by P2PDEST should be the same as the address specified by HOSTADDR on the IPOWNER definition statement.<sup>6</sup> In the case where backup IP channel interfaces are defined (see “Backup IP Channel Interfaces” on page 15-8), this paragraph applies only to the IPLOCAL statement for the primary IP channel interface.

SNETMASK defines a mask that identifies the subnetwork address portion of the internet host address. The subnetwork mask determines which portion of the internet address, defined by the LADDR keyword, identifies the subnetwork. For more information, see “Specifying Internet Subnetwork Addresses” on page 15-6.

### Optional Interface Definition for ESCON Channel Resources

For ESCON channel internet resources, there are two methods of defining internet interfaces.

- The first method is to code an IPLOCAL definition statement and its associated keywords. This method is also supported for NCST, frame relay, 370 I/O channels, Ethernet, and Token Ring.
- The second method is to define the necessary interface definition keywords on the PU statement (for example, LADDR and P2PDEST). The IPLOCAL statement must be omitted, when using this option. Also, this option is not available if a channel is used for direct communication with NCPROUTE.

---

<sup>6</sup> This restriction does not apply in the absence of SNALINK, where the remote NCP definition must use an indirect path to NCPROUTE via an NCST connection to a local NCP that has an IP channel connection to the NCPROUTE host.

## Defining Ethernet-Type LAN Attachments

An ESS adapter in the communication controller enables you to connect a physical line between NCP and an Ethernet Version 2 or IEEE 802.3 network. The NCP internet router forwards IP datagrams through an Ethernet-type LAN to internet hosts or routers attached to the LAN. NCP can also be an internet gateway between different LAN types (IEEE 802.3, Ethernet V2, and Token Ring).

**Notes:**

1. To support dynamic route table update through RIP, the ESS adapter in your controller must have one of the following microcode levels:
  - C38006 for the IBM 3745 Models 130, 150, 160, and 170
  - C37967 for the IBM 3745 Models 210, 310, 410, and 610
  - D39888 for the IBM 3745 Models 21A, 31A, 41A, and 61A
  - D400002 for the IBM 3745 Model 17A.
2. To support ESS adapter multicasting of RIPv2 multicast packets, the ESS adapter microcode patch EGAL2 is required.

Code the following definition statements and keywords to define a line group with an Ethernet-type LAN attachment.

GROUP	ETHERNET
LINE	ADDRESS FRAMECNT INTERFACE LOCADD
PU	ANS ARPTAB LANTYPE PUTYPE
IPLOCAL	INTERFACE LADDR METRIC PROTOCOL SNETMASK

**GROUP**

ETHERNET on the GROUP definition statement specifies that the lines in a group are connected to an Ethernet-type LAN. Code ETHERNET=PHYSICAL.

**LINE**

ADDRESS on the LINE definition statement specifies the relative line number associated with the ESS adapter.

FRAMECNT defines reporting threshold values for the total number of frames transmitted or received during an error cycle and the total number of frames that can be lost due to transmission and receive errors during an error cycle. If either threshold is reached, NCP generates an alert and sends it to the NetView program. NCP

## Defining Ethernet-type LAN Attachments

also builds a box event record (BER 08B7) to be sent to MOSS. Refer to *NCP and EP Reference* and *NCP and EP Reference Summary and Data Areas*, Volume 2 for information about Ethernet-type LAN alerts. Information about BERs can be found in *NCP and EP Reference Summary and Data Areas*, Volume 1.

**Note:** The minimum recommended value for the transmission error threshold is 300 for normal operation; however, lower FRAMECNT threshold values can be useful for testing and problem determination. Low values used for normal operation can reduce performance and cause an excessive number of statistical messages to be sent to the host.

INTERFACE assigns a name to the ESS adapter for the line and, optionally, specifies the maximum frame size for the adapter. The adapter name is used to associate the adapter with a particular Ethernet-type LAN interface. To make this association, specify the same name for the following keywords:

- INTERFACE on the LINE definition statement that defines the physical line to the LAN
- INTERFACE on the IPLOCAL definition statement that defines the internet interface to the LAN.

LOCADD defines the locally administered address of the ESS adapter. You do not need to code LOCADD; if you omit LOCADD, NCP uses the hardware address of the ESS adapter. You can determine the hardware address of the ESS adapter by using the MOSS EID function. Refer to *IBM 3745 Advanced Operations Guide* for information about this function.

## PU

ANS on the PU definition statement specifies whether service to the Ethernet-type LAN continues or stops when your NCP enters automatic network shutdown. Code ANS=CONTINUE to ensure link operation if NCP enters automatic network shutdown. Sessions will continue with other access methods and applications that are unaffected by the shutdown.

ARPTAB defines the following Address Resolution Protocol (ARP) characteristics:

- The maximum number of temporary entries in the ARP table. NCP uses the ARP table to convert internet addresses to physical hardware addresses. The value you specify should equal the maximum number of temporary devices you expect to be attached to the Token Ring at any one time. This number does not include the number of permanent addresses defined by the IPHOST definition statement.

**Note:** An ARPTAB value that is too large will waste memory. An ARPTAB value that is too small can result in poor performance because of the increased number of ARP requests. Refer to *NCP and EP Reference* for information on how NCP manages ARP tables.

- How long NCP is to wait after the last ARP exchange to a host has taken place before removing the corresponding temporary entry from the table. If NCP has data to transmit to a host whose entry has been removed from the table, NCP and the host perform an ARP exchange to create a new table entry for the host before NCP transmits the data. This ensures that the ARP table is always current.

LANTYPE specifies which frame formats the Ethernet-type attachment is to support: IEEE 802.3, Ethernet Version 2, or both.

**Note:** NCP performance is slightly lower when you define support for both formats, so you should not do so unless the attachment will actually carry both formats.

PUTYPE defines the type of physical unit associated with the connection. Code PUTYPE=1 to identify an Ethernet-type LAN link station.

### IPLOCAL

The IPLOCAL definition statement defines characteristics of the Ethernet-type LAN interface to the NCP internet router; it also implicitly defines a route to the LAN. (For more information on implicitly defined routes, see “Routes Implicitly Defined by NCP Internet Interfaces” on page 15-53.) Code an IPLOCAL definition statement, including the INTFACE keyword, for each LAN interface.

INTFACE on the IPLOCAL definition statement assigns a name to the LAN interface. This name is used to associate the interface with a particular ESS adapter. To make this association, specify the same name for the following keywords:

- INTFACE on the LINE definition statement that defines the physical line to the LAN
- INTFACE on the IPLOCAL definition statement that defines the internet interface to the LAN.

INTFACE is required. The value of INTFACE on each IPLOCAL definition statement in your generation definition must be unique.

LADDR defines the internet address for the internet router interface. This address is used by all other nodes in the network to refer to this interface. The value of LADDR must be a valid address in the network or subnetwork to which this interface is attached. LADDR is required. The value of LADDR on each IPLOCAL definition statement in your generation definition must be unique.

METRIC assigns a metric (a value from 1 to 15) to the interface. NCP and TCP/IP use the metric to determine the best route to a destination. For more information, see the description of METRIC on the IPRROUTE definition statement on page 15-55.

PROTOCOL specifies whether this interface is to be managed by NCPROUTE in the owning IBM TCP/IP host through RIP. If you code PROTOCOL=NONE, the interface is not defined to NCPROUTE, and NCP does not broadcast RIP information about its internet routes through this interface. This enables you to define interfaces that are managed through protocols other than RIP. For more information on NCPROUTE, refer to *NCP and EP Reference*.

SNETMASK defines a mask that identifies the subnetwork address portion of the internet host address. The subnetwork mask determines which portion of the internet address, defined by the LADDR keyword, identifies the subnetwork. For more information, see “Specifying Internet Subnetwork Addresses” on page 15-6.

### NDF-Added Keywords for Ethernet-Type LAN Attachments

When you code ETHERNET=PHYSICAL on the GROUP definition statement to define an Ethernet-type LAN attachment, NDF adds the following keywords to your generation definition if you do not code them.

## Defining Ethernet-type LAN Attachments

```
GROUP DIAL=NO,  
      LNCTL=SDLC  
PU    INNPORT=YES,  
      LPDA=BLOCK,  
      NPACOLL=NO, 1  
      PUTYPE=1
```

<sup>1</sup> Added if NPA=YES is coded on the BUILD definition statement.

Figure 15-6. NDF-Added Keywords for Ethernet-Type LAN Attachments

### Defining an Internet Host Attached to an Ethernet-Type LAN

NCP Address Resolution Protocol (ARP) support enables internet router LAN interfaces to dynamically determine the hardware addresses of internet hosts.

However, the IPHOST definition statement lets you create a permanent internet address, which means that you associate an internet host's hardware address with its internet address in your generation definition.

IPHOST is required for all internet hosts that communicate with NCP but do not support ARP. When you change the hardware address associated with the internet address of an internet host that does not support ARP, you must update your NCP generation definition and regenerate NCP.

**Note:** IPHOST is not valid for internet connections to a frame-relay network or a channel.

Defining a permanent internet address for internet hosts that support ARP may improve performance because storage is already defined for these internet hosts. ARP transmits ARP frames to determine the internet host's hardware address and dynamically creates storage, both of which can affect performance.

However, consider the following when defining a permanent internet address:

- Defining a permanent internet address uses more storage, which you must define in your NCP generation definition.
- If you change the hardware address of your internet host, you have to update your NCP generation definition and regenerate NCP.
- Without ARP, if you add internet hosts to your LAN, you have to update your NCP generation definition and regenerate NCP.
- With ARP, internet frames can be lost if the ARP process fails.
- All internet hosts defined in your NCP generation definition are permanent. If an internet host is removed from the LAN, NCP storage for that host remains allocated.

**Note:** You do not need to define temporary ARP table entries for permanent internet addresses. See "Defining Ethernet-Type LAN Attachments" on page 15-25 for more information.

To define a permanent address for an internet host attached to a LAN, the IPHOST definition statement must follow the PU definition statement that defines the LAN interface. If you have more than one permanent internet host, code one IPHOST definition for each host on the LAN.

Code the following definition statements and keywords to define a permanent internet host address.

IPHOST	HDWADDR
	LANTYPE

HDWADDR on the IPHOST definition statement specifies the hardware address of the internet host. To determine the hardware address, refer to the documentation for the workstation.

IPADDR specifies the 4-byte internet address of the internet host.

LANTYPE specifies which frame formats will be transmitted between NCP and the internet host: IEEE 802.3, Ethernet Version 2, or both. If you code LANTYPE=DYNAMIC on the PU definition statement to define support for both formats, also code LANTYPE on the IPHOST definition statement to specify which format the host supports.

### Sample Coding to Define an Ethernet-Type LAN Attachment

Figure 15-7 shows an NCP with two Ethernet-type LAN attachments. Interface ETH2 has internet address 96.0.0.99, and interface ETH3 has internet address 128.81.0.96. This configuration is a subset of the network configuration shown in Figure 15-18 on page 15-61.

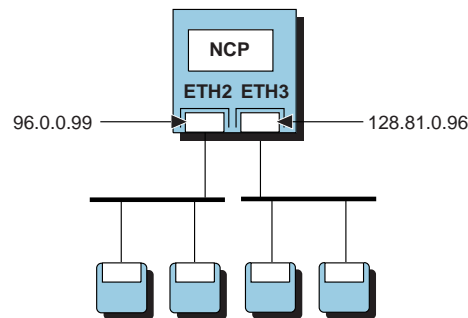

Figure 15-7. Ethernet-Type LAN Attachments

Figure 15-8 on page 15-30 shows how to define the Ethernet-Type LAN attachments shown in Figure 15-7. You do not need to code IPHOST definition statements to define the internet hosts attached to the LANs because these hosts will be discovered through ARP.

## Defining Ethernet-type LAN Attachments

```

*****
*   ETHERNET ADAPTER INTERFACES   *
*****
*
A03ETH  GROUP  ETHERNET=PHYSICAL,                                X
          DIAL=NO,          DIAL=NO added to GROUP by NDF      X
          ISTATUS=ACTIVE,   VTAM-only keyword                  X
          LNCTL=SDLC,
          VIRTUAL=NO        The default is NO
*****
A03E170  LINE  ADDRESS=(1070,FULL), * INTERFACE TO ETHERNET2 (ETH2) X
          ANS=CONT,          X
          FRAMECNT=(100000,5000), Frames allowed in cycle max/err X
          INTFACE=ETH2,      ETH2 is the routing interface name X
          LANTYPE=DYNAMIC    Supports both types (802.3 & V2)
*
A03P170  PU    ANS=CONT,          X
          ARPTAB=(2000,20),   ARP table size/timer             X
          INNPORT=YES,       INNPORT=YES added to PU by NDF    X
          PUTYPE=1
*****
A03E171  LINE  ADDRESS=(1071,FULL), * INTERFACE TO ETHERNET3 (ETH3) X
          ANS=CONT,          X
          FRAMECNT=(100000,5000), Frames allowed in cycle max/err X
          INTFACE=ETH3,      ETH3 is the routing interface name X
          LANTYPE=DYNAMIC    Supports both types (802.3 & V2)
*
A03P171  PU    ANS=CONT,          X
          ARPTAB=(2000,20),   ARP table size/timer             X
          INNPORT=YES,       INNPORT=YES added to PU by NDF    X
          PUTYPE=1
*
          .                Channel adapter, non-native
          .                network, and path definitions
          .
*****
*   IP ROUTING DEFINITIONS   *
*****
          .
          .                Definitions of owning IBM TCP/IP
          .                host and NCST interface
*
*   ETHERNET INTERFACE CHARACTERISTICS
*
          IPLOCAL LADDR=96.0.0.99, 96.0.0.99 is the IP address *
          INTFACE=ETH2,          ETH2 is the interface name   *
          METRIC=1,              Standard hop in an internet route *
          PROTOCOL=RIP
          IPLOCAL LADDR=128.81.0.96, 128.81.0.96 is the IP address *
          INTFACE=ETH3,          ETH3 is the interface name   *
          METRIC=1,              Standard hop in an internet route *
          PROTOCOL=RIP
*

```

Figure 15-8. Example: Defining Ethernet-Type LAN Attachments



## Defining NTRI Attachments for IP

NCP can use a NTRI-attached Token-Ring LAN as an internet transmission medium. The NCP internet router forwards IP datagrams through a type 1 or type 2 Token-Ring interface coupler (TIC) to hosts or routers attached to the Token Ring. NCP can also function as an internet gateway between different LAN types (IEEE 802.3, Ethernet V2, and Token Ring).

**Note:** Unlike SNA NTRI connections, you do not need to define logical lines for internet NTRI connections.

Code the following definition statements and keywords to define a NTRI attachment for Internet Protocol.

GROUP	ADAPTER ECLTYPE
LINE	ADDRESS BEACTO DATBLK <sup>1</sup> INTERFACE LOCADD MAXTSL NPACOLL PORTADD RCVBUFC TRSPEED
PU	ADDR ANS ARPTAB COMRATE <sup>1</sup> NETWORK PASSLIM <sup>2</sup> PUTYPE
IPLOCAL	INTERFACE LADDR METRIC PROTOCOL SNETMASK
<sup>1</sup> Supported starting with NCP V7R3. <sup>2</sup> Supported only for NCP V7R1 and NCP V7R2.	

### GROUP

ADAPTER on the GROUP definition statement defines the type of TIC in the communication controller. For internet support:

- Code ADAPTER=TIC1 to define a type 1 TIC (4 Mbps).
- Code ADAPTER=TIC2 to define a type 2 TIC (4 or 16 Mbps).

## Defining NTRI Attachments for IP

The type 3 TIC also supports internet traffic. See “Defining an Internal NCP to Model 900 Point-to-Point IP Connection” on page 15-39.

ECLTYPE identifies the type of Token-Ring resources defined by the line group. Specify ECLTYPE=PHYSICAL or ECLTYPE=(PHYSICAL,*type*) for an internet attachment. The value specified for *type*, SUBAREA, PERIPHERAL, or ANY, does not affect the use of the NTRI attachment for IP datagram routing. For more information about defining ECLTYPE for SNA logical lines, see Chapter 6.

### LINE

ADDRESS on the LINE definition statement specifies the relative line number associated with the NTRI adapter.

BEACTO identifies the beaconing timeout value, which is the length of time NCP pauses to allow a failed Token Ring to recover. If the Token Ring cannot recover from the beaconing condition before the time coded on BEACTO elapses, support for the internet interface to this line is disabled. Refer to *NCP and EP Reference* for further information on beaconing.

DATABLK specifies the minimum transmission bandwidth in bytes that can be allocated to a resource. DATABLK is used with the *priority* suboperand of the COMRATE keyword to determine a relative priority among protocols. The value of the *priority* suboperand of COMRATE is multiplied by the value of DATABLK to determine the minimum guaranteed number of bytes provided for a protocol for the transmission of associated traffic before a different protocol is provided a transmission opportunity. See “Defining Token-Ring Physical Connections” on page 6-6 for information about coding COMRATE.

INTERFACE assigns a name to the NTRI attachment and specifies the maximum size for Token-Ring internet frames. The attachment name is used to associate the attachment with a particular NTRI internet interface. To make this association, specify the same name for the following keywords:

- INTERFACE on the LINE definition statement that defines the attachment to the Token Ring
- INTERFACE on the IPLOCAL definition statement that defines the internet interface to the Token Ring.

LOCADD identifies the 6-byte hexadecimal hardware address of the TIC that connects NCP to an IBM Token-Ring Network.

MAXTSL specifies the maximum amount of data that NCP is to transmit in a single NTRI frame. MAXTSL has different ranges and defaults depending on ECLTYPE, ADAPTER, and TRSPEED values. See “Frame Size” on page 6-40 for information on how to use MAXTSL.

NPACOLL specifies whether the NTRI physical line is eligible for performance data collection through NPM.

PORTADD assigns a port identification number (0–99) used to identify the TIC to VTAM. PORTADD applies to the definition of the NTRI physical line; it has no meaning for the internet function.

RCVBUFC defines the NCP buffer capacity for receiving data from an IBM Token-Ring Network during one data transfer. The RCVBUFC value must be greater than

or equal to the maximum number of bytes a NTRI physical line can receive in one data transfer operation. One data transfer operation includes the NTRI header, the subnetwork access protocol (SNAP) header, and the IP datagram. The RCVBUFC minimum value is 6 times the value coded for BFRS on the BUILD definition statement; the RCVBUFC maximum value depends on the type of adapter. The default value assigned to RCVBUFC depends on values coded on the ADAPTER and ECLTYPE keywords. See “Frame Size” on page 6-40 for more details on how to use RCVBUFC.

TRSPEED specifies the speed of the Token Ring to which NCP will be attached, either 4 Mbps or 16 Mbps. See “Token-Ring Speed” on page 6-39 for more details.

## PU

ADDR on the PU definition statement defines the link station address of the physical unit. You do not need to code ADDR for an internet NTRI attachment, but if you code ADDR, code ADDR=02.

ANS determines whether service to the Token Ring continues or stops when your NCP enters automatic network shutdown. Code ANS=CONTINUE to ensure link operation if NCP enters automatic network shutdown. Sessions will continue with other access methods and applications that are unaffected by the shutdown. If you code multiple PU definition statements under the same LINE definition statement, code the same value for ANS on all of the PU definition statements.

ARPTAB defines the following ARP characteristics:

- The maximum number of temporary entries in the ARP table. NCP uses the ARP table to convert internet addresses to physical hardware addresses. The value you specify should equal the maximum number of temporary devices you expect to be attached to the Token Ring at any one time. This number does not include the number of permanent addresses defined by the IPHOST definition statement.

**Note:** An ARPTAB value that is too large will waste memory. An ARPTAB value that is too small can result in poor performance because of the increased number of ARP requests. Refer to *NCP and EP Reference* for information on how NCP manages ARP tables.

- How long NCP is to wait after the last ARP exchange to a host has taken place before removing the corresponding temporary entry from the table. If NCP has data to transmit to a host whose entry has been removed from the table, NCP and the host perform an ARP exchange to create a new table entry for the host before NCP transmits the data. This ensures that the ARP table is always current.
- The format (canonical or noncanonical) of hardware addresses received through ARP. All the Token-Ring devices and internet hosts in the network must use the same format. The default format for both NCP and IBM TCP/IP is noncanonical format.

COMRATE on the PU definition statement specifies the relative priority of a protocol (SNA, IP, frame relay), as represented by the physical units defined on the physical line, as compared to all other protocols on the physical line. It should be coded as COMRATE=(*priority*). The value of the *priority* suboperand of COMRATE is multiplied by the value of DATBLK on the LINE definition statement

## Defining NTRI Attachments for IP

(see “Defining Token-Ring Physical Connections” on page 6-6 for more information about the DATBLK keyword.)

The relative priority of a protocol can be determined by the fraction of the total available transmission time allocated the protocol. This fraction is calculated by dividing the sum of the COMRATE *priority* values of each physical unit on the line representing the protocol by the sum of the *priority* values calculated for each of the other protocols represented on the line:

$$\frac{\text{Protocol 1's } \textit{priority} \text{ value}}{\text{The sum of } \textit{priority} \text{ values of all PUs on or associated with the physical line}}$$

For example, if there are three PUs for a line, PU1's transmission fraction is determined like this:

$$\frac{\text{PRIORITY}_{\text{PU1}}}{\text{PRIORITY}_{\text{P1}} + \text{PRIORITY}_{\text{P2}} + \text{PRIORITY}_{\text{P3}}}$$

(PRIORITY = The value of the *priority* suboperand of the COMRATE keyword.)

NETWORK specifies whether this physical unit represents a connection to an SNA network, a frame-relay network, or an internet. To define a NTRI attachment to an internet, code NETWORK=IP, and also code INTFACE on the LINE definition statement.

PASSLIM determines the maximum number of consecutive Token-Ring SNA frames NCP is to transmit before checking for Token-Ring internet frames to be transmitted. PASSLIM can help you control the mixture of internet and SNA traffic over a Token-Ring attachment. For NCP V7R3 and later, a mechanism for sharing bandwidth between network protocols associated with COMRATE on the PU definition statement replaces the mechanism associated with PASSLIM.

PUTYPE defines the type of physical unit associated with the connection. Code PUTYPE=1 to define a Token-Ring link station.

## IPLOCAL

The IPLOCAL definition statement defines characteristics of the NTRI interface to the NCP internet router, and also implicitly defines a route to the Token Ring. (For more information on implicitly defined routes, see “Routes Implicitly Defined by NCP Internet Interfaces” on page 15-53.) Code an IPLOCAL definition statement, including the INTFACE keyword, for each NTRI interface.

INTFACE on the IPLOCAL definition statement assigns a name to the LAN interface. This name is used to associate the interface with a particular NTRI attachment. To make this association, specify the same name for the following keywords:

- INTFACE on the LINE definition statement that defines the attachment to the Token Ring
- INTFACE on the IPLOCAL definition statement that defines the internet interface to the Token Ring.

INTFACE is required. The value of INTFACE on each IPLOCAL definition statement in your generation definition must be unique.

LADDR defines the internet address for the internet router interface. This address is used by all other nodes in the network to refer to this interface. The value of LADDR must be a valid address in the network or subnetwork to which this interface is attached. LADDR is required. The value of LADDR on each IPLOCAL definition statement in your generation must be unique.

METRIC assigns a metric (a value from 1 to 15) to the interface. NCP and TCP/IP use the metric to determine the best route to a destination. For more information, see the description of METRIC on the IPROUTE definition statement on page 15-55.

PROTOCOL specifies whether this interface is to be managed by NCPROUTE in the owning IBM TCP/IP host through RIP. If you code PROTOCOL=NONE, the interface is not defined to NCPROUTE, and NCP does not broadcast RIP information about NCP internet routes through this interface. This enables you to define interfaces that are managed through protocols other than RIP. For more information on NCPROUTE, refer to *NCP and EP Reference*.

SNETMASK defines a mask that identifies the subnetwork address portion of the internet host address. The subnetwork mask determines which portion of the internet address, defined by the LADDR keyword, identifies the subnetwork. For more information, see “Specifying Internet Subnetwork Addresses” on page 15-6.

### Defining Internet Hosts Attached to a Token-Ring LAN

NCP Address Resolution Protocol (ARP) support enables internet router LAN interfaces to dynamically determine the hardware addresses and the source route of internet hosts. However, the IPHOST definition statement lets you create a permanent internet address, which means that you associate an internet host’s hardware address with its internet address in your generation definition.

Internet hosts defined with the IPHOST definition statement must reside on the local ring segment in a LAN that is source-route bridged. This is because NCP’s ARP support determines the source route of the host.

IPHOST is required for all internet hosts that communicate with NCP but do not support ARP. When you change the hardware address associated with the internet address of an internet host that does not support ARP, you must update your NCP generation definition and regenerate NCP.

Defining a permanent internet address for internet hosts that support ARP may improve performance because storage is already defined for these internet hosts. NCP’s ARP support transmits ARP frames to determine the internet host’s hardware address and dynamically creates storage, both of which may affect performance.

However, consider the following when defining a permanent internet address:

- Defining a permanent internet address uses more storage, which you must define in your NCP generation definition.
- If you change the hardware address of your internet host, you have to update your NCP generation definition and regenerate NCP.
- Without ARP, if you add internet hosts to your LAN, you have to update your NCP generation definition and regenerate NCP.

## Defining NTRI Attachments for IP

- With ARP, internet frames can be lost if the ARP process fails.
- All internet hosts defined in your NCP generation definition are permanent. If an internet host is removed from the LAN, NCP storage for that host remains allocated.
- Defining the hardware address of an internet host in your NCP generation definition reduces ARP broadcast traffic, which may improve utilization of the LAN.

The number of ARP table entries defined on the PU definition statement does not need to include the permanent internet addresses you define.

**Note:** For devices that do not support ARP, the only way to change the hardware address associated with an internet host address is to update the NCP generation definition and regenerate NCP.

To define a permanent address entry for an internet host attached to a LAN, the IPHOST definition statement must follow the PU definition statement used to define the LAN interface. If you have more than one permanent internet host, repeat the IPHOST definition for each host on the LAN. Each internet host defined with an IPHOST definition statement must reside on the local Token-Ring segment.

Code the following definition statement and keywords to define a permanent internet host address.

```
IPHOST      HDWADDR
            IPADDR
```

Define internet host addresses by providing NCP with address information.

HDWADDR on the IPHOST definition statement specifies the hardware address of the internet host. To determine the hardware address, refer to the documentation for the workstation.

IPADDR specifies the 4-byte internet address of the internet host.

### Sample Coding to Define a NTRI Internet Attachment

Figure 15-9 shows a NTRI internet attachment that supports both SNA and internet traffic. The interface, TR88, has internet address 128.81.0.94. This configuration is a subset of the network configuration shown in Figure 15-18 on page 15-61.

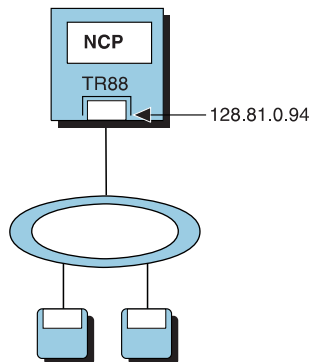

Figure 15-9. NTRI Internet Attachment

Figure 15-10 on page 15-38 shows how to define the NTRI internet attachment shown in Figure 15-9. The PU definition statements define the SNA and internet attachments to the Token Ring. You do not need to code IPHOST definition statements to define the internet hosts attached to the Token Ring because these hosts will be discovered through ARP.

## Defining NTRI Attachments for IP

```

*****
*      NCP/TOKEN RING INTERCONNECT PHYSICAL LINES      *
*****
*
A03NTR1  GROUP  ANS=CONTINUE,                               *
              ADAPTER=TIC2,                               *
              ECLTYPE=(PHYSICAL,ANY),                     *
              MAXTSL=16732,                               *
              RCVBUFC=32000,                              *
              RETRIES=(20,5,5),                           *
              USSTAB=AUSSTAB,                             *
              XID=NO,                                     *
              TYPE=NCP,                                   *
              DIAL=NO,                                    *
              LNCTL=SDLC,                                 *
              LEVEL2=ECLNARL2,                           *
              LEVEL3=ECLNARL3,                           *
              LEVEL5=NCP,                                 *
              TIMER=(ECLNART1,,ECLNART2,ECLNART3),        *
              XIO=(ECLNARXL,ECLNARXS,ECLNARXI,ECLNARXK), *
              USERID=(5668854,ECLRBDT,NORECMS,,ECLNMVT), *
              SPEED=9600,                                 *
              NPACOLL=NO,                                 *
              PUTYPE=1,                                   *
              PUDR=NO,                                    *
              COMPTAD=YES,                                *
              COMPSWP=YES,                                *
              COMPOWN=YES
*****
*      ADDRESS 1088:  NTRI PHYSICAL LINE - SUBAREA/PERIPHERAL  *
*****
*
A03TR88  LINE  ADDRESS=(1088,FULL),                         *
              INTERFACE=TR88,                             *
              LOCADD=400000000331,                       *
              PORTADD=1,                                  *
              TRSPEED=16,                                 *
              UACB=(X$P1AX,X$P1AR)
*
*      PU FOR SNA TRAFFIC
*
A03PU88  PU  ADDR=01,                                     *
              NETWORK=SNA,                               *
              PUTYPE=1,                                   *
              INNPORT=YES
*
*      PU FOR IP TRAFFIC
*
A03PU88A PU  ADDR=02,                                     *
              ARPTAB=(1000,20,NOTCANON),                 *
              NETWORK=IP,                                 *
              PUTYPE=1,                                   *
              INNPORT=YES
.
.
.

```

Figure 15-10 (Part 1 of 2). Coding Example: Defining a NTRI Internet Attachment



```

*****
*   IP ROUTING DEFINITIONS                               *
*****
*
*   TOKEN RING INTERFACES
*
*   IPLOCAL LADDR=128.81.0.94,INTFACE=TR88,METRIC=1,    *
*   PROTOCOL=RIP
*
*

```

Figure 15-10 (Part 2 of 2). Coding Example: Defining a NTRI Internet Attachment

### Defining an Internal NCP to Model 900 Point-to-Point IP Connection

NCP supports the coupling of the 3746 Model 900 IP router with NCP's IP router. As shown in Figure 15-11, the joining of these IP routers enables IP traffic to flow between 3746 Model 900-attached IP connections and 3745-attached IP connections. The 3746 Model 900 IP Routing Hardware Feature (F/N 5033) is required to support the internal NCP to Model 900 point-to-point IP connection.

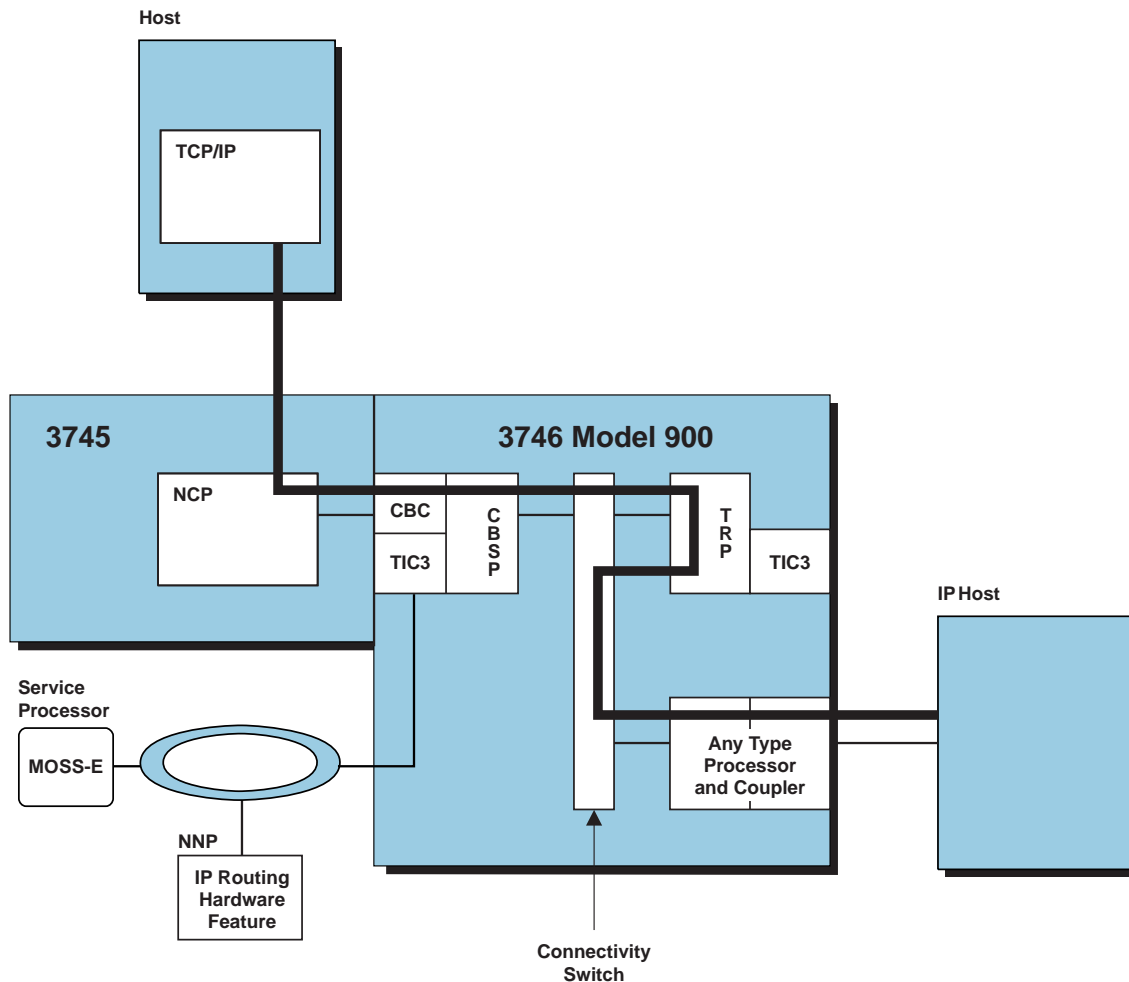

Figure 15-11. Sample IP Network with an Internal NCP to Model 900 Point-to-Point IP Connection

## Internal Router-to-Router Connection

**Note:** Unlike SNA 3746 Model 900 Token-Ring connections, you do not need to define logical lines for internal NCP to Model 900 point-to-point IP connections.

An internal NCP to Model 900 point-to-point IP connection is defined by coding a PU statement with PUTYPE=1 and NETWORK=IP beneath a LINE statement that defines an 3746 Model 900-attached Token-Ring physical link.

Code the following definition statements and keywords to define an internal NCP to Model 900 point-to-point IP connection:

GROUP	ADAPTER ECLTYPE
LINE	ADDRESS BEACTO LOCADD MAXPU MAXTSL NPACOLL PORTADD SPEED TRSPEED
PU	ADDR ANS INTERFACE NETWORK NPACOLL PUTYPE XMONLNK
IPLOCAL	INTERFACE LADDR <sup>1</sup> METRIC <sup>1</sup> PROTOCOL <sup>1</sup> P2PDEST <sup>1</sup> SNETMASK <sup>1</sup>

<sup>1</sup>LADDR, METRIC, PROTOCOL, P2PDEST, and SNETMASK can also be coded on the PU definition statement.

## GROUP

ADAPTER on the GROUP definition statement defines the type of TIC in the communication controller. For internal NCP to Model 900 point-to-point IP connections, code ADAPTER=TIC3.

ECLTYPE identifies the type of Token-Ring resources defined by the line group. Specify ECLTYPE=PHYSICAL or ECLTYPE=(PHYSICAL,*type*) for an internet attachment. The value specified for *type*, SUBAREA, PERIPHERAL, or ANY, does not affect the IP datagram routing. For more information about defining ECLTYPE for SNA logical lines, see Chapter 6.

**LINE**

ADDRESS on the LINE definition statement specifies the relative line number associated with the TIC adapter.

BEACTO identifies the beaconing timeout value, which is the length of time NCP pauses to allow a failed Token Ring to recover. If the Token Ring cannot recover from the beaconing condition before the time coded on BEACTO elapses, support for the internet interface to this line is disabled. Refer to *NCP and EP Reference* for further information on beaconing.

LOCADD identifies the 6-byte hexadecimal hardware address of the TIC that connects NCP to an IBM Token-Ring Network.

MAXPU specifies the number of PUs associated with the physical line. The Token-Ring physical line can support an SNA physical unit and an IP physical unit. The maximum value for MAXPU is 2, and the default value is the number of physical PUs defined.

MAXTSL specifies the maximum amount of data that NCP is to transmit in a single frame. MAXTSL has different ranges and defaults depending on the ECLTYPE, ADAPTER, and TRSPEED values. See "Frame Size" on page 6-40 for information on how to use MAXTSL.

NPACOLL specifies whether the physical line is eligible for performance data collection through NPM.

PORTADD assigns a port identification number (0–99) used to identify the TIC to VTAM. See page 6-11 for information on how to use PORTADD. PORTADD applies to the definition of the 3746 Model 900 Token-Ring physical line; it has no meaning for the internet function.

SPEED sets an estimated data transmission rate to be used by NPM to compute line utilization statistics.

TRSPEED specifies the speed of the Token Ring to which NCP will be attached, either 4 Mbps or 16 Mbps. See "Token-Ring Speed" on page 6-39 for more details.

**PU**

ADDR on the PU definition statement defines the link station address of the physical unit. For a PU that defines an internal NCP to Model 900 point-to-point IP connection, ADDR=02 is the only valid value.

ANS determines whether service to the Token Ring continues or stops when your NCP enters automatic network shutdown. See page 6-12 for information on how to use ANS.

INTFACE specifies the maximum size for Token-Ring internet frames and can also specify the IP router interface name. The *name* suboperand associates the attachment with a particular 3746 Model 900 Token-Ring internet interface. To make this association, specify the same name for the INTFACE keyword on the IPLOCAL definition statement that defines the internet interface between the IP router and the IP host. The omission of the INTFACE keyword or the *name* suboperand from the PU definition statement indicates that:

## Internal Router-to-Router Connection

- The IP interface parameters (LADDR, METRIC, PROTOCOL, P2PDEST, and SNETMASK) are coded on the PU statement, rather than on an associated IPLOCAL statement.
- The PU label name is used as the interface name instead of the *name* suboperand.

NETWORK specifies whether this physical unit represents a connection to an SNA network or an internet. To define an 3746 Model 900 Token-Ring attachment to an internet, code NETWORK=IP.

NPACOLL specifies whether the internal IP connection is eligible for performance data collection through NPM.

PUTYPE defines the type of physical unit associated with the connection. Code PUTYPE=1 to define an internal NCP to Model 900 point-to-point IP connection.

XMONLNK specifies whether the SMMF is to initially activate this connection. If you code XMONLNK=NO, VTAM must activate the connection. For more information, see the discussion of SMMF in the *NCP and EP Reference*.

## IPLOCAL

The IPLOCAL definition statement defines the interface between the IP router and one or more associated IP hosts. The interface name on the INTFACE keyword of the PU statement associates an IP host with a particular interface.

Because an internal NCP to Model 900 point-to-point IP connection is always point-to-point, the keywords normally defined on the IPLOCAL statement can be coded directly on the PU statement representing this connection. In such a case, you must omit the IPLOCAL definition statement for that interface. Conversely, if you do not code the IPLOCAL keywords on the PU definition statement, you must code one IPLOCAL statement for each internal NCP to Model 900 point-to-point IP connection that you define.

INTFACE on the IPLOCAL definition statement assigns a name to the internet router interface. This name must be the same as the *name* suboperand on the INTFACE keyword on the PU statement that defines the internal NCP to Model 900 point-to-point IP connection. INTFACE is required when you choose to code an IPLOCAL definition statement for an internal NCP to Model 900 point-to-point IP connection.

LADDR defines the internet address for the internet router interface. This address is used by all other nodes in the network to refer to this interface. The LADDR value must be a valid address in the network or subnetwork to which this interface is attached. LADDR is required and must be coded either on the PU definition statement or on the IPLOCAL definition statement that has the same INTFACE name as the PU statement. Each LADDR value in your generation must be unique.

METRIC assigns a metric (a value from 1 to 15) to the interface. METRIC is optional for an internal NCP to Model 900 point-to-point IP connection. NCP and TCP/IP use the metric to determine the best route to a destination. For more information, see the description of METRIC on the IPROUTE definition statement on page 15-55.

PROTOCOL specifies whether this interface is to be managed by NCPROUTE in the owning IBM TCP/IP host through RIP. If you omit the PROTOCOL keyword, it defaults to RIP. If you code PROTOCOL=NONE, the interface is not defined to NCPROUTE, and NCP does not broadcast RIP information about NCP internet routes through this interface. This enables you to define interfaces that are managed through protocols other than RIP. For more information on NCPROUTE, refer to *NCP and EP Reference*.

P2PDEST specifies the internet address for the destination internet host. This address must be unique to NCP and must match the IP address in the 3746 Model 900 Controller Configuration and Management (CCM) definitions for the 3746 Model 900 side of the internal NCP to Model 900 point-to-point IP connection. P2PDEST is required for an internal NCP to Model 900 point-to-point IP connection and must be coded either on the PU definition statement or on the ILOCAL definition statement that has the same INTFACE name as the PU statement.

SNETMASK defines a mask that identifies the subnetwork address portion of the internet host address. The subnetwork mask determines which portion of the internet address, defined by the LADDR keyword, identifies the , subnetwork. For more information, see “Specifying Internet Subnetwork Addresses” on page 15-6. If coded, the SNETMASK value must match the subnetwork mask in the 3746 Model 900 Controller Configuration and Management (CCM) definitions for the 3746 Model 900 side of the internal NCP to Model 900 point-to-point IP connection.

### **Sample Coding to Define an Internal NCP to Model 900 Point-to-Point IP Connection**

Figure 15-12 on page 15-44 shows how to define an internal NCP to Model 900 point-to-point IP connection.

## Defining Frame-Relay Attachments for IP

```
*****
*  TOKEN RING LINE 2240                                     *
*****
*
A71PGRP1 GROUP ECLTYPE=(PHY,ANY),ADAPTER=TIC3,             *
              DIAL=NO,LNCTL=SDLC,TYPE=NCP
A712240  LINE ADDRESS=(2240,FULL),SPEED=9600,TRSPEED=16,MAXPU=2, *
              LOCADD=400000002240,                          *
              MAXTSL=16732,                                  *
              NPACOLL=YES,                                   *
              PORTADD=2
A712240A PU ADDR=01,                                       *
              ANS=CONTINUE,                                  *
              INNPORT=YES,                                   *
              NETWORK=SNA                                    *
              PUDR=NO,                                       *
              PUTYPE=1,                                       *
              XID=NO,                                         *
              XMONLNK=YES
A712240B PU ADDR=02,                                       *
              ANS=CONTINUE,                                  *
              INTERFACE=(,2048),INNPORT=YES,                *
              LADDR=10.71.88.99,                             *
              METRIC=1,                                       *
              NETWORK=IP,                                     *
              NPACOLL=YES,                                   *
              PUTYPE=1,                                       *
              PROTOCOL=RIP,                                   *
              P2PDEST=10.04.92.99
*
*
```

Figure 15-12. Coding Example: Defining an Internal NCP to Model 900 Point-to-Point IP Connection

## Defining Frame-Relay Attachments for IP

NCP can use a frame-relay network as an internet transmission medium. The NCP internet router forwards IP datagrams through TSS and HPTSS adapters to hosts or routers attached to the frame-relay network.

IP can be defined over a nonswitched 3745 frame-relay physical line as well as a switched 3745 frame-relay physical line. For nonswitched frame-relay physical lines, IP PUs are defined on the physical LINE statement and keywords are specified on the physical line/PU.

For switched frame-relay physical lines, only one physical PU (the LMI PU) can be defined on the physical LINE statement. In order to represent the IP attachment, IP logical PUs are defined under a nonswitched logical LINE statement which is associated to the switched frame-relay physical line via the PHYSRSC keyword. IP-related keywords are specified on the corresponding logical line/PU. Logical IP PUs are PUTYPE=1. Only one IP logical LINE can be defined under a frame-relay IP logical GROUP statement. In addition, only one IP logical line can be associated with any one switched frame relay physical line.

Code the following definition statements and keywords for frame-relay IP attachments, under the physical line/PU for **nonswitched** frame-relay physical lines and under the logical line/PU for **switched** frame-relay physical lines.

For a switched frame-relay physical line, the keywords are specified on the corresponding IP logical line. For a nonswitched frame-relay physical line, the keywords are specified on the actual physical line.

Switched:

GROUP      FRELAY  
                 PHYSRSC

LINE        ARPTAB<sup>1</sup>

Nonswitched:

GROUP      FRELAY

LINE        ADDRESS  
                 ARPTAB<sup>1</sup>  
                 CLOCKING  
                 DATABLK  
                 SPEED

<sup>1</sup> ARPTAB is required only when you want to dynamically add frame-relay IP resources.

PU            COMRATE  
                 DLCI  
                 INTERFACE  
                 IPQLIM  
                 PUTYPE

IPOWNER    NUMDRIF

IPLOCAL    INTERFACE  
                 LADDR<sup>2</sup>  
                 METRIC<sup>2</sup>  
                 PROTOCOL<sup>2</sup>  
                 P2PDEST<sup>2</sup>  
                 SNETMASK<sup>2</sup>

<sup>2</sup> LADDR, METRIC, PROTOCOL, P2PDEST, and SNETMASK can also be coded on the PU definition statement.

## GROUP

FRELAY on the GROUP definition statement defines a frame-relay line group.

### Switched

Specify FRELAY=(LOGICAL,IP) for a switched internet attachment. PHYSRSC associates the logical line with a switched physical line. Specify the name of the PU definition statement for the link station on the physical line.

PHYSRSC=*name* is required.

### Nonswitched

Specify `FRELAY=PHYSICAL` or `FRELAY=(PHYSICAL,type)` for a nonswitched internet attachment.

## LINE

### Switched

The **logical** LINE definition statement is required, but the LINE definition statement for the associated **physical** line provides the keywords with one exception: The ARPTAB keyword is coded on the logical LINE statement. See the description of the ARPTAB keyword under the following “Nonswitched” section.

### Nonswitched

ADDRESS on the LINE definition statement specifies the relative line number associated with the frame-relay physical line.

ARPTAB defines the following Address Resolution Protocol (ARP) characteristics:

- The maximum number of temporary entries in the ARP table. NCP uses the ARP table to convert internet addresses to physical hardware addresses. The value you specify should equal the maximum number of temporary devices you expect to dynamically add to the physical connection at any one time.

**Note:** An ARPTAB value that is too large will waste memory. An ARPTAB value that is too small can result in poor performance because of the increased number of ARP requests. Refer to *NCP and EP Reference* for information on how NCP manages ARP tables.

- The format of hardware addresses received through ARP. Code noncanonical format for frame-relay internet connections.

CLOCKNG specifies whether the modem (data set) or the communication scanner for the line provides clocking. Refer to the SPEED keyword on the LINE definition statement for additional information.

DATABLK specifies the minimum transmission bandwidth in bytes that can be allocated to a resource or a protocol. DATABLK is used with the *priority* suboperand of the COMRATE keyword or FRRATES keyword to determine the relative priority among resources and supported protocols respectively. The value of the *priority* suboperand is multiplied by the value of DATABLK to determine the guaranteed minimum number of bytes that a resource or protocol can transmit before a different resource or protocol must be given a transmission opportunity. See the following description of the PU statement for information about coding COMRATE.

SPEED specifies the data rate for the line.

## PU

COMRATE on the PU definition statement specifies the relative priority of the IP station on the frame-relay physical line.

**NCP V7R5 and Earlier Releases:** COMRATE specifies the relative priority of the IP station as compared to all of the other associated physical stations and associated logical lines.

The *priority* suboperand (coded as `COMRATE=(,priority)`) specifies a relative priority of an internet host. The value of the *priority* suboperand of COMRATE is multiplied by the value of DATABLK on the LINE definition statement for the physical line to determine the guaranteed minimum



number of bytes that a resource can transmit before a different resource must be given a transmit opportunity. (See the description of the LINE statement, earlier in this section, for information about coding DATABLK.)

The relative priority for an IP station can be determined as a fraction of the total available transmission time on a line that a station gets. This fraction is calculated by dividing the station's COMRATE *priority* value by the sum of the COMRATE *priority* values for all stations on the line:

$$\frac{\text{PU1's } \textit{priority} \text{ value}}{\text{Sum of } \textit{priority} \text{ values of all PUs on or associated with the physical line}}$$

For example, if there are three PUs for a line, PU1's transmission fraction is determined like this:

$$\frac{\text{PRIORITY}_{\text{PU1}}}{\text{PRIORITY}_{\text{PU1}} + \text{PRIORITY}_{\text{PU2}} + \text{PRIORITY}_{\text{PU3}}}$$

Where PRIORITY = the value of the respective PU's *priority* suboperand of the COMRATE keyword.

**NCP V7R6 and Later Releases:** COMRATE specifies the relative priority of the IP station as compared to all other IP stations associated with the same 3745 frame-relay physical line.

The *priority* suboperand (coded as COMRATE=(,*priority*)) specifies a relative priority of an internet host. The value of the *priority* suboperand of COMRATE is multiplied by the value of DATABLK on the LINE definition statement for the physical line to determine the guaranteed minimum number of bytes that a resource can transmit before a different resource must be given a transmit opportunity. (See the description of the LINE statement, earlier in this section, for information about coding DATABLK.)

The relative priority of an IP station can be determined as a fraction of the total available bandwidth afforded the IP protocol that the station receives. This fraction is calculated by dividing the IP station's COMRATE *priority* value by the sum of the COMRATE *priority* values for all IP stations associated with the line:

$$\frac{\text{IP PU1's } \textit{priority} \text{ value}}{\text{Sum of } \textit{priority} \text{ values of all IP PUs associated with the physical line}}$$

For example, if three IP PUs are associated with a physical line, PU1's transmission fraction of the IP protocol's total bandwidth is determined like this:

$$\frac{\text{PRIORITY}_{\text{PU1}}}{\text{PRIORITY}_{\text{PU1}} + \text{PRIORITY}_{\text{PU2}} + \text{PRIORITY}_{\text{PU3}}}$$

Where PRIORITY = the value of the respective PU's *priority* suboperand of the COMRATE keyword.

In addition to using the COMRATE keyword to specify *priority* values for IP stations, you can use the FRRATES keyword to specify a *priority* value for

## Defining Frame-Relay Attachments for IP

the IP protocol. See page FRRATES on the LINE Definition Statement on page 16-11.

DLCI on the PU definition statement assigns a 2-byte (10 bit) data link connection identifier (DLCI) to each PVC within the frame-relay network. The value of DLCI on each PU in your generation definition must be unique.

You can also define a DLCI for a single frame-relay resource using the ADDR keyword (1-byte, 8-bit).

INTERFACE on the PU assigns a name to the internet interface and specifies the maximum size for frame-relay internet frames. The attachment name is used to associate the attachment with a particular frame-relay internet interface. To make this association, specify the same name for the following keywords:

- INTERFACE on the PU definition statement that defines the internet interface for the frame-relay network
- INTERFACE on the IPLOCAL definition statement that specifies to the frame-relay network the name of the internet interface for which the local internet address is being defined.

**Note:** When a corresponding IPLOCAL definition statement is not specified, the PU label name for the PU definition statement is used as the attachment name.

IPQLIM specifies the amount of data which can be queued on a frame-relay IP interface outbound queue awaiting transmission.

PUTYPE defines the type of physical unit associated with the internet connection.

### IPOWNER

NUMDRIF on the IPOWNER definition statement specifies the number of frame-relay internet interfaces that can be dynamically reconfigured to this NCP, and how many of the dynamically reconfigured interfaces are eligible for NPM data collection.

**Note:** DYNPOOL coded on the BUILD definition statement may cause the number of dynamically allocated control blocks to exceed the value specified by NUMDRIF, which can affect storage utilization. See the chapter on control block management in the *NCP and EP Reference* for additional information.

### IPLOCAL

INTERFACE on the IPLOCAL definition statement assigns a name to the internet interface. This name is used to associate the interface with a particular frame-relay attachment. To make this association, specify the same name for the following keywords:

- INTERFACE on the PU definition statement that defines the internet interface to the frame-relay network.
- INTERFACE on the IPLOCAL definition statement that defines the attachment to the frame-relay network.

INTERFACE is required if you do not define the interface on the PU definition statement. The value of INTERFACE on each IPLOCAL definition statement in your generation definition must be unique.

LADDR defines the internet address for the internet router interface. This address is used by all other nodes in the network to refer to this interface. The value of

LADDR must be a unique address on each IPLOCAL definition statement in your generation.

METRIC assigns a metric (a value from 1 to 15) to the interface. NCP and TCP/IP use the metric to determine the best route to a destination. For more information, see the description of METRIC on the IPRROUTE definition statement on page 15-55.

PROTOCOL specifies whether this interface is to be managed by NCPROUTE in the owning IBM TCP/IP host through RIP. If you code PROTOCOL=NONE, the interface is not defined to NCPROUTE, and NCP does not broadcast RIP information about NCP internet routes through this interface. This enables you to define interfaces that are managed through protocols other than RIP. For more information on NCPROUTE, refer to *NCP and EP Reference*.

P2PDEST specifies the host address of the frame destination frame-relay internet host partner for this point-to-point connection.

SNETMASK defines a mask that identifies the subnetwork address portion of the internet host address. The subnetwork mask determines which portion of the internet address, defined by the LADDR keyword, identifies the subnetwork. For more information, see "Specifying Internet Subnetwork Addresses" on page 15-6.

### Optional Interface Definition for Frame-Relay Resources

For frame-relay internet resources, there are two methods to use to define internet interfaces.

- The first method is to code an IPLOCAL definition statement and its associated keywords. This method is also supported for NCST, channel, Ethernet, and Token Ring.
- The second method is to define the necessary interface definition keywords on the PU statement (for example, LADDR, METRIC, PROTOCOL, SNETMASK, and P2PDEST). The IPLOCAL statement must be omitted, when using this option.

### Sample Coding to Define Frame-Relay Internet Attachments

Figure 15-13 on page 15-50 shows frame-relay internet attachments that support both frame-relay frames and internet traffic. The nonswitched interface, FRIPPU52, has internet address 128.10.03.99. The switched interface, FRIPPU53, has internet address 129.10.03.99.

## Defining Frame-Relay Attachments for IP

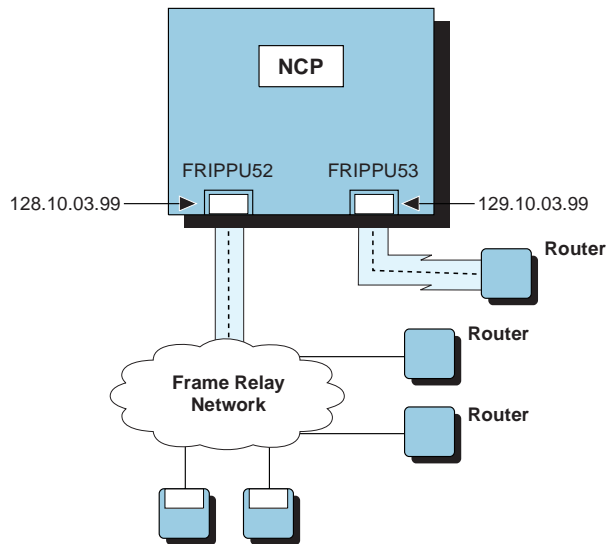

Figure 15-13. Frame-Relay Internet Attachments

Figure 15-14 on page 15-51 shows how to define the frame-relay internet attachments shown in Figure 15-13. The first two PU definition statements define the link station support and nonswitched internet attachment to a frame-relay network. The last PU definition statement defines a switched internet attachment.

```

*****
* FRAME RELAY NONSWITCHED PHYSICAL LINE 052 - FULL DUPLEX 56KB *
*****
*
A03FRGP2 GROUP FRELAY=PHYSICAL, *
                ISTATUS=ACTIVE, *
                MAXFRAME=2106, *
                XMONLNK=YES, *
                TYPE=NCP, *
                DIAL=NO, *
                LNCTL=SDLC, *
                NPACOLL=(YES,EXTENDED), *
                PUTYPE=1
*
A03F52 LINE ADDRESS=(052,FULL), *
        CLOCKNG=EXT, *
        NRZI=NO, *
        ARPTAB=(40,,NOTCANON), *
        SPEED=56000
*
A03P52 PU ANS=CONTINUE, *
        PUDR=NO, *
        NPACOLL=(YES,EXTENDED), *
        INNPORT=YES
*
FRIPPU52 PU PUTYPE=1, X
          ADDR=3A, X
          P2PDEST=128.10.31.99, X
          SNETMASK=255.255.255.0, X
          PROTOCOL=RIP, X
          METRIC=1, X
          INTFACE=(,500), X
          LADDR=128.10.03.99
          .
          .
          .

```

Figure 15-14 (Part 1 of 2). Coding Example: Defining Frame-Relay Internet Attachments over Switched and Nonswitched Frame-Relay Physical Lines

## Defining Internet Routes

```
*****
* FRAME-RELAY SWITCHED PHYSICAL LINE 053 *
*****
SPGRP3  GROUP FRELAY=(PHYSICAL,PER), Dial physical peripheral line *
        DIAL=YES
*
SPHYLP53 LINE ADDRESS=(016,FULL), TSS adapter address is 16 *
          MAXFRAME=2106, Maximum frame size *
          NRZI=YES, NRZI mode. The default is NO *
          PORTADD=33, Port number is 33 *
          SPEED=9600, Line speed *
          ID=00456789, Node ID *
          V25BIS=(YES,DLSDLC), V.25Bis *
          DATABLK=4096
*
*****
* LOGICAL LINE GROUP *
*****
LGRP    GROUP FRELAY=(LOGICAL,IP) Logical peripheral line
*
A03P53  LINE ARPTAB=(40,,NOTCANON)
*
FRIPPU53 PU PUTYPE=1, X
          ADDR=3B, X
          P2PDEST=129.10.31.99, X
          SNETMASK=255.255.255.0, X
          PROTOCOL=RIP, X
          METRIC=1, X
          INTERFACE=(,500), X
          LADDR=129.10.03.99
          .
          .
          .
```

Figure 15-14 (Part 2 of 2). Coding Example: Defining Frame-Relay Internet Attachments over Switched and Nonswitched Frame-Relay Physical Lines

## Defining Internet Routes

IP datagrams travel between networks and subnetworks along paths called *internet routes*. The NCP internet router can send and receive datagrams on any internet route that passes through NCP. This section describes how NCP internet routes are defined.

In general, NCP internet routes are defined in three different ways:

- In an internet network that supports RIP, NCP's internet routing information is provided by NCPROUTE in the NCP owning IBM TCP/IP host. As a result, *if your network supports RIP, you do not need to define internet routes in your NCP generation definition*. Routes will be automatically defined through RIP. For more information, see "Routes Defined by NCPROUTE through RIP" on page 15-53.
- When you define an NCP internet interface to a directly attached NCST logical unit, Ethernet-type LAN, NTRI-attached Token-Ring LAN, internal NCP to Model 900 point-to-point IP connection, frame-relay network, or channel-attached host; a route to the logical unit, LAN, or network is implicitly defined. Do not define routes to directly attached destinations in your NCP generation

definition. For more information, see “Routes Implicitly Defined by NCP Internet Interfaces” on page 15-53.

- If your internet network does not support RIP, or if you want internet routes that cannot be changed by RIP, you can define internet routes in your generation definition to destinations not directly attached to NCP. For a complete description, see “Defining Routes Explicitly” on page 15-54.

The remainder of this section describes these three ways of defining internet routes.

## Routes Defined by NCPROUTE through RIP

NCP maintains a list of available internet routes in the NCP *routing information table (RIT)*. If your NCP is part of an internet network that supports RIP, the RIT is continually updated through RIP by NCPROUTE, an application that runs in the NCP owning IBM TCP/IP host.

Starting with V7R6, NCP supports RIP Version 2 in addition to RIP Version 1. The version of RIP that you use can be configured per NCP or per NCP internet interface. This configuration is done in NCPROUTE.

When you initialize NCP, the RIT contains routes implicitly defined by NCP internet interfaces, and routes explicitly defined in your generation definition. Thereafter, NCPROUTE adds, changes, and deletes routes based on information supplied by other internet routers in the network. Because NCPROUTE keeps informed of all currently available routes, you may not need to explicitly define any internet routes.

The RIT contains two types of entries:

- *Permanent routes* cannot be added, changed, or deleted by NCPROUTE. Routes implicitly defined by NCP’s internet interfaces are permanent routes, and you can explicitly define additional permanent routes in your generation definition.
- *Temporary routes (or nonpermanent routes)* can be added, changed and deleted by NCPROUTE. It is recommended that you use as many temporary routes as possible, that is, explicitly define as few permanent routes as possible. This enables NCPROUTE to keep NCP routing information as current as possible.

For more information on explicitly defining permanent routes, see “Defining Routes Explicitly” on page 15-54. For more information on NCPROUTE, refer to *NCP and EP Reference*.

## Routes Implicitly Defined by NCP Internet Interfaces

When you code an IPLOCAL definition statement to define an interface to a directly attached NCST logical unit, Ethernet-type LAN, NTRI-attached Token-Ring LAN, internal NCP to Model 900 point-to-point IP connection, frame-relay network, or channel-attached host, NCP automatically defines a permanent route for the interface as follows:

- For an NCST interface, NCP automatically defines a host route over which it can route traffic to the NCST logical unit. The address of the NCST logical unit is specified by P2PDEST on the IPLOCAL definition statement.

## Defining Internet Routes

- For an interface to an Ethernet-type or NTRI-attached LAN, NCP automatically defines a route to the network or subnetwork in which the LAN resides, over which it can route traffic to destinations on the LAN. The address of the network or subnetwork in which the LAN resides is specified by LADDR on the IPLOCAL definition statement.
- For an internal NCP to Model 900 point-to-point IP connection, NCP automatically defines a route to the IP host at the 3746 Model 900 end of the point-to-point connection. The address of the IP host is specified by P2PDEST on the IPLOCAL or PU definition statement.
- For a frame-relay interface, NCP automatically defines a host route over which it can route traffic to the frame-relay network. The address of the destination unit is specified by P2PDEST on the IPLOCAL or PU definition statement.
- For a channel interface, NCP automatically defines a host route over which it can route traffic to the channel-attached host. The address of the destination unit is specified by P2PDEST on the IPLOCAL or PU definition statement.

Implicitly defined routes have a route metric of 1. For more information on route metrics, see the description of METRIC on page 15-55.

In your generation definition, do not explicitly define routes to directly attached NCST logical units, LANs, frame-relay networks, or channel-attached hosts. However, you can define routes to remote destination accessed through a directly attached NCST logical unit, LAN, frame-relay network, or channel-attached host, as described in the following section.

For more information on defining NCP internet interfaces, see the following sections:

- “Defining NCST Session Interfaces” on page 15-8
- “Defining Ethernet-Type LAN Attachments” on page 15-25
- “Defining NTRI Attachments for IP” on page 15-31
- “Defining an Internal NCP to Model 900 Point-to-Point IP Connection” on page 15-39
- “Defining Frame-Relay Attachments for IP” on page 15-44
- “Defining 370 I/O Channels for IP” on page 15-18

## Defining Routes Explicitly

As described previously, because NCPROUTE can provide NCP with information on currently available internet routes, you may not need to explicitly define internet routes in your generation definition. However, if your internet network does not support RIP, or if you want internet routes that cannot be changed by RIP, you can define internet routes explicitly. This section describes how to do this.

**Note:** Remember, do not explicitly define a route to a directly attached NCST logical unit, LAN, frame-relay network, or channel-attached host. For more information, see “Routes Implicitly Defined by NCP Internet Interfaces” on page 15-53.

Code the following definition statement and keywords to define internet routes.



BUILD	VSUBNETS <sup>1</sup>
IPROUTE	DESTADDR
	DISP
	HOSTRT
	INTERFACE
	METRIC
	NEXTADDR
	SNETMASK <sup>1</sup>

<sup>1</sup> Supported starting with NCP V7R6.

## BUILD

VSUBNETS on the BUILD definition statement specifies whether variable subnetting is supported via NDF and dynamic reconfiguration.

### Notes:

1. If NCPRROUTE is configured to use RIP-2, NCPRROUTE can add variable subnetted routes regardless of the value of VSUBNETS in NCP.
2. VSUBNETS=YES must be specified to enable receiving Ethernet multicast frames for RIP-2. The Ethernet adapter (ESS) patch EGAL2 must also be applied when VSUBNETS=YES.

## IPROUTE

The IPROUTE definition statement defines an internet route. Code one IPROUTE definition statement to define a route to a destination network, subnetwork, or internet host.

DESTADDR on the IPROUTE definition statement specifies the address of the network, subnetwork, or internet host destination for this route definition. For a direct route, the value of DESTADDR must be a valid address in the network or subnetwork to which this interface is attached. NDF interprets this address as an internet host address only if you specify HOSTRT=YES for this route. Otherwise, the address is interpreted as a network or subnetwork destination.

DISP specifies whether the route you are defining is to be permanent. If you code DISP=PERM, the route is not managed by the owning IBM TCP/IP host and, consequently, cannot be dynamically deleted or changed. If you define more than one route to a destination to provide backup routes, code DISP=PERM for each route. Code DISP=PERM or omit DISP for a route to the owning IBM TCP/IP host.

HOSTRT specifies whether the destination of the route you are defining is an internet host.

INTERFACE specifies the name of the internet router interface that is to be used for this route. IP datagrams with destination addresses that match the destination address of a route (DESTADDR) are transmitted over the interface identified by the name specified for INTERFACE.

METRIC assigns a metric (a value from 1 to 15) to the internet route. The metrics for internet routes and their associated NCP interfaces (METRIC on the IPLOCAL definition statement) are used to determine the best route to a destination. NCP and TCP/IP use the route with the smallest combined metric. This may be a route

## Defining Internet Routes

defined (either explicitly or implicitly) in your generation definition, or it may be a route discovered through RIP.

The number of internet routers between this NCP and the destination (the *hop count*) is commonly used as the METRIC value for a route so that the shortest route will be used. However, you may wish to use other values if the shortest route is not the most desirable.

For more information on internet route selection, refer to *Internetworking with TCP/IP Volume I: Principles, Protocols, and Architecture*.

NEXTADDR specifies the internet address of the next router on the route to the destination. The value of NEXTADDR must be a valid address in the network or subnetwork that contains this route. If you explicitly define more than one route for a particular NCST interface, the value of NEXTADDR must be the same for each route.

SNETMASK specifies the subnetwork mask to associate with the destination address (DESTADDR) when defining a subnetwork route. The subnetwork mask determines which portion of an internet address, defined by the DESTADDR keyword, identifies the subnetwork. The SNETMASK value must contain the network portion of the internet address defined by DESTADDR. See *NCP, SSP, and EP Resource Definition Reference* for additional information on coding the SNETMASK keyword.

### Sample Coding to Define an Internet Route to a Subnetwork

Figure 15-15 shows an internet configuration where NCP communicates with a remote Ethernet-type LAN through a NTRI-attached Token Ring. The NTRI interface to the Token Ring is in Subnetwork A, while the Ethernet-type LAN is in Subnetwork C.

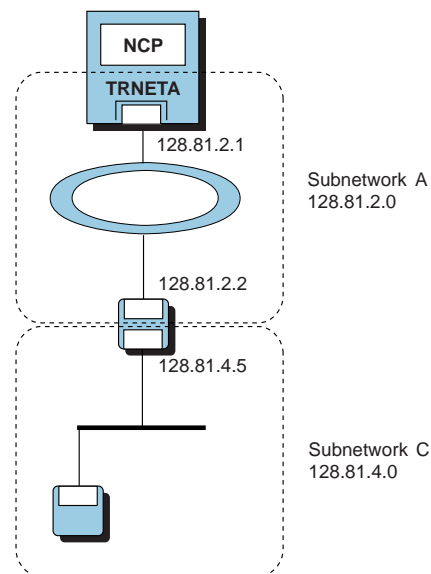

Figure 15-15. Internet Routing to a Subnetwork

Figure 15-16 on page 15-57 shows how to define the configuration shown in Figure 15-15. Note the following:

## Migrating Internet Resources to NCP V7R1 and Later Releases

- The IPLOCAL definition statement for the NTRI interface also defines the subnetwork mask for this network (the SNETMASK keyword). For more information on subnetwork masks, see “Specifying Internet Subnetwork Addresses” on page 15-6.
- The route to Subnetwork A is implicitly defined by the IPLOCAL definition statement for the NTRI interface.

```
*****
*   INTERNET ROUTING DEFINITIONS                               *
*****
*
*   LOCAL INTERNET INTERFACES
*
*
*       .
*       .
*       IPLOCAL INTFACE=TRNETA,      Interface to Token Ring A      *
*           LADDR=128.81.2.1,        Address of interface          *
*           METRIC=1,                Interface metric is 1            *
*           SNETMASK=255.255.255.0  Use 3rd byte for subnetwork      *
*                                     addresses in network 128.81
*
*       .
*       .
*
*   INTERNET ROUTE TO SUBNETWORK C VIA SUBNETWORK A
*
*   RTSUBC  IPRROUTE DESTADDR=128.81.4.0,  Route to subnetwork C      *
*           DISP=NONPERM,                Route can be altered by RIP  *
*           INTFACE=TRNETA,              Indirect route through TRNETA *
*           METRIC=1,                     Route goes through 1 hop      *
*           NEXTADDR=128.81.2.2          Next hop address is 128.81.2.2
```

Figure 15-16. Coding Example: Defining an Internet Route to a Subnetwork

## Dynamic Reconfiguration of Frame Relay Internet Hosts

See “Dynamic Reconfiguration for Frame-Relay Internet Devices” on page 10-6.

---

## Migrating Internet Resources to NCP V7R1 and Later Releases

If your NCP generation definition includes internet resources for NCP V6R1, NCP V6R2, or NCP V6R3, you need to update your generation definition to generate the equivalent internet resources for NCP V7R1 or later. The migration aid function of NDF can make most of the required changes automatically; you need only code appropriate values for certain keywords. For more information on the migration aid function, see “Migration Aid Function” on page 2-18. For a complete description of the migration aid function, including the changes it makes for internet resources, refer to *NCP V7R8 Migration Guide*.

If you do not want to use the migration aid function, you can update your generation definition manually. To do this, make the following changes. Refer to the preceding sections of this chapter for more information on the definition statements and keywords described here.

1. Code one IPOWNER definition statement to define the IBM TCP/IP host that will manage the NCP routing table, if dynamic routing is desired.

## Migrating Internet Resources to NCP V7R1 and Later Releases

2. With NCP V6R1, NCP V6R2, or NCP V6R3, you can define a default local internet address by omitting the INTFACE keyword from the IPLOCAL definition statement. If you are using a default local internet address, you now need to define a unique internet address for each local internet interface. Replace the default IPLOCAL definition statement with an IPLOCAL definition statement for each local internet interface that is not already explicitly defined and define a unique host address for each interface.
3. Update each IPLOCAL definition statement as follows:
  - a. Add METRIC to each IPLOCAL definition statement to enable NCP to determine the best route to a destination.
  - b. Add P2PDEST to each IPLOCAL definition statement that defines an NCST session interface.
  - c. Add PROTOCOL=NONE to each IPLOCAL definition statement for an interface that is not to be managed through RIP.
4. Delete all IPSUB definition statements.

With NCP V6R1, NCP V6R2, or NCP V6R3, each internet interface could have its own subnetwork mask.

NCP V7R1 through NCP V7R5 allow only one subnetwork mask per network, so code the SNETMASK keyword on the first IPLOCAL definition statement in the network that is being divided into subnetworks. All local internet interfaces within that network will use that subnetwork mask.

Starting with NCP V7R6, the restriction of a single subnetwork mask per network no longer applies.

5. Update all internet route definitions as follows:
  - a. Change all IPGATE definition statements to IPRROUTE definition statements.
  - b. You may wish to delete the IPRROUTE definition statements for routes that will be managed by NCPROUTE through RIP. For more information, see "Routes Defined by NCPROUTE through RIP" on page 15-53.
  - c. Delete all IPRROUTE definition statements for routes implicitly defined by NCP internet interfaces. For more information, see "Routes Implicitly Defined by NCP Internet Interfaces" on page 15-53.
  - d. Add the METRIC keyword to each remaining IPRROUTE definition statement. If you want the route definition to be permanent (not subject to change by IBM TCP/IP), code DISP=PERM on the IPRROUTE definition statement.
6. In NCP V7R1 or later, backup routes must be permanent, so if you have more than one IPRROUTE definition statement with the same DESTADDR value, delete all but one of those IPRROUTE definition statements or code DISP=PERM for all those IPRROUTE definition statements.

---

## Coding Internet Route Definitions for Best Performance

NCP's internet functions can introduce a variety of NCP performance concerns. For example:

- In certain circumstances, internet traffic can monopolize network resources and restrict SNA traffic.
- A high-speed LAN can deliver IP datagrams at a higher rate than NCP can handle, causing them to be discarded.
- SNA and internet traffic together can exhaust the NCP storage buffers, causing NCP to enter a slowdown state.

Code the following definition statements and keywords to minimize such performance concerns and to collect performance data on NCP internet resources.

BUILD	CNLSQMAX CNLSQTIM IPPOOL IPRATE IPSNAP SLOWDOWN
LINE	NPACOLL
PU	IPQLIM

### BUILD

CNLSQMAX specifies the maximum amount of data that can be queued on an NCST, Ethernet or Token-Ring type LAN interface outbound queue awaiting transmission. CNLSQMAX does not apply to frame relay or channel interfaces.

CNLSQTIM specifies how many seconds a frame is to stay in the outbound queue for an NCST, Ethernet-type or Token-Ring LAN, or frame-relay interface. When the time limit expires, the frame is discarded. CNLSQTIM does not apply to channel interfaces.

IPPOOL limits the number of NCP buffers that can be used to receive IP datagrams. When the amount of internet data exceeds this limit, the excess IP datagrams are discarded. Limiting the number of buffers for IP datagrams can help prevent internet traffic from interfering with SNA traffic. If you do not limit the number of buffers for IP datagrams, internet traffic can use enough NCP buffers to cause NCP to enter slowdown even when SNA traffic is light.

IPRATE defines the maximum rate at which internet frames can be received. This prevents internet traffic from monopolizing the communication controller. When the maximum rate is exceeded, the adapter accepts internet frames only when NCP is idle; otherwise, arriving frames (except for ARP and RIP frames) are discarded.

IPSNAP specifies whether the NCP snap trace is to be enabled for internet resources. You can trace NCPROUTE dynamic routing updates, IP datagrams received or routed by NCP, or both.

## Sample Internet Resource Configuration and Definitions

**Note:** The snap trace can degrade NCP performance and should be used only when requested by an IBM support representative.

SLODOWN establishes NCP buffer slowdown and warning thresholds. NCP limits the size of individual internet session queues to the number of bytes specified by the CNLSQMAX keyword when the percentage of available buffers drops below the warning threshold. NCP discards IP datagrams when the percentage of available buffers drops below the slowdown threshold.

### LINE

NPACOLL on the LINE definition statement specifies whether the resources for a line are eligible for NPM performance data collection.

### PU

IPQLIM specifies the maximum amount of data which can be queued on a frame relay IP interface outbound queue awaiting transmission. IPQLIM is only valid for frame relay IP interfaces.

## Sample Coding for Internet Performance

Figure 15-17 shows how to code some of the keywords that pertain to NCP internet performance and gives a typical value for each keyword.

```
*****
*      NCP BUILD MACRO - NCP/CONTROLLER INFO      *
*****
*
*      A03NCP  BUILD CNLSQMAX=10000,      Maximum size of IP session queues X
*              CNLSQTIM=10,              Time allowed in outbound session q X
*              IPPOOL=NCP,              NCP calculates IP share of buffers X
*              IPRATE=(40,50),          Max frames accepted in .1 seconds X
*              SLODOWN=12,              Slowdown at 12% of buffers remain X
*              .
*              .
```

Figure 15-17. Coding Example: Coding Keywords for Internet Performance

---

## Sample Internet Resource Configuration and Definitions

This section shows a sample internet network configuration and the NCP generation definitions that define it. Figure 15-18 on page 15-61 shows two NCPs, NCP1 and NCP2, connected to MVS hosts, Ethernet-type LANs, Token Rings, frame relay, and channel In this configuration:

- NCP1 has the following NCST sessions:
  - A session with its owning IBM TCP/IP host (A17) through NCST interface IPOWNER
  - A session with host A01 through NCST interface HOSTA01
  - A primary session and a backup session with NCP2 through NCST interface INTF2. (The primary and backup sessions are not shown separately in the figure.)

NCP2 has the following NCST sessions:

- A session with its owning IBM TCP/IP host (B01) through NCST interface IPOWNER

## Sample Internet Resource Configuration and Definitions

- A session with host C01 through NCST interface HOSTC01
- A primary session and a backup session with NCP1 through NCST interface INTF1. (The primary and backup sessions are not shown separately in the figure.)
- NCP1 and NCP2 have the following Ethernet-type LAN and NTRI attachments:
  - NCP1 is attached to two Ethernet-type LANs through interfaces ETH2 and ETH3, and to a Token Ring through interface TR88.
  - NCP2 is attached to one Ethernet-type LAN through interface ETH3 and to a Token Ring through interface TR92.
- NCP1 and NCP2 have the following SNA connections:
  - NCP1 is channel-attached to its owning IBM TCP/IP host (A17), and can also establish an NCST session with host A01 over an SNA subarea link to controller A04.
  - NCP2 is channel-attached to its owning IBM TCP/IP host (B01), and to an additional host (C01).

These channel links and subarea links are not included in the sample generation definitions that follow.

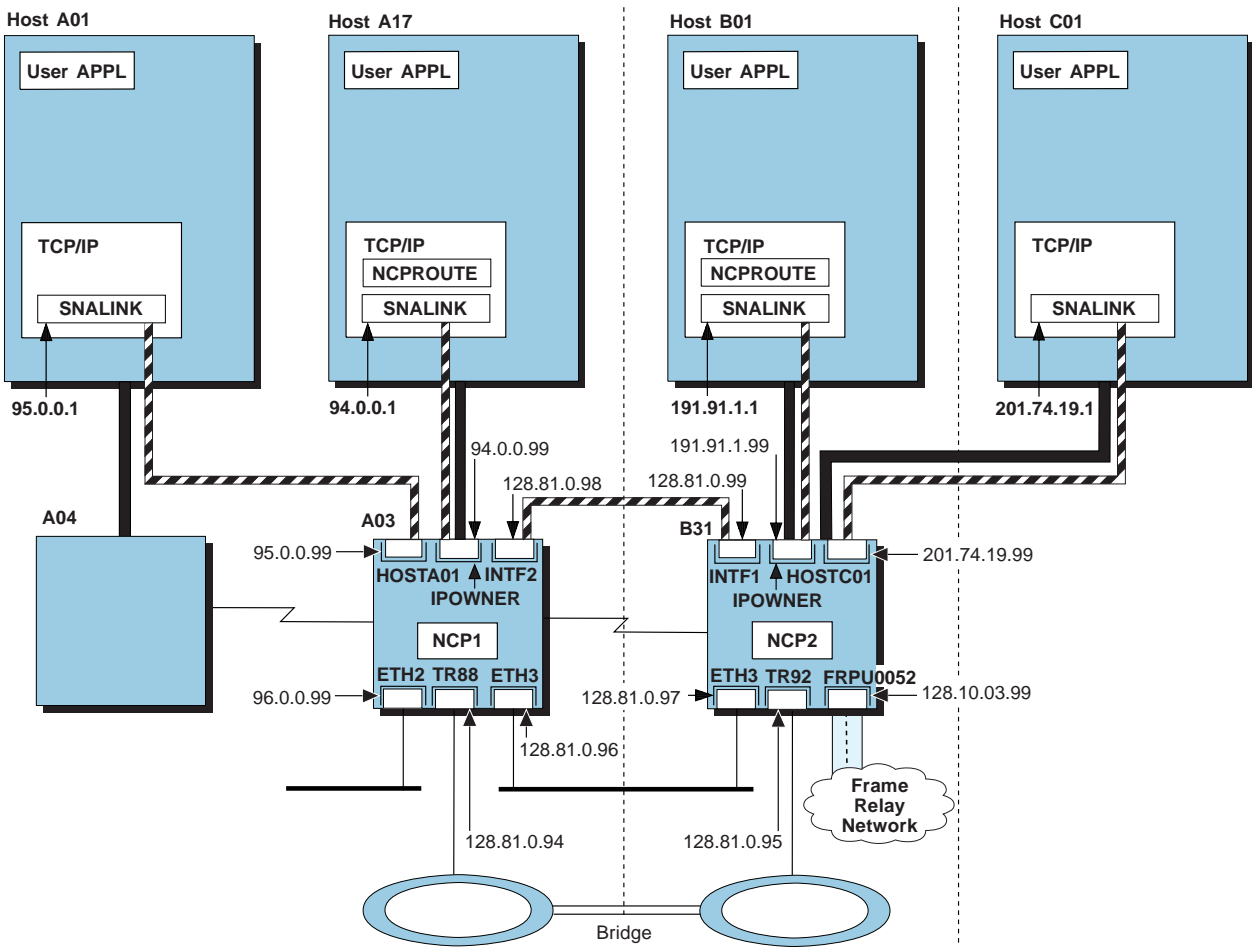

Figure 15-18. Internet Configuration with NCPs, MVS hosts, Ethernet-Type LANs, and Token Rings

## Sample Internet Resource Configuration and Definitions

Figure 15-19 on page 15-63 shows how to define the internet resources shown in Figure 15-18. Notice that Figure 15-19 shows portions of two separate generation definitions, one for NCP1 and one for NCP2.

**Note:** These sample generation definitions are portions of the sample generation definitions in Appendix A, “NCP V7R8 Sample Generation Definitions” (NCP A03 and NCP B31). Figure A-2 on page A-7 and Figure A-5 on page A-128 show the complete NCP generation definitions for these two NCPs.



## Sample Internet Resource Configuration and Definitions

```

*****
*                               NCP1                               *
*****
*****      A03NCP - NCP FOR SAMPLES NETWORK  SUBAREA 03      *****
*****
*                               .                               *
*                               .                               *
*                               .                               *
*                               .                               *
*****
*      NCP/TOKEN RING INTERCONNECT PHYSICAL LINES              *
*****
*
A03NTR1  GROUP  ANS=CONTINUE,                                     *
          ADAPTER=TIC2,                                         *
          ECLTYPE=(PHYSICAL,ANY),                               *
          MAXTSL=16732,                                         *
          RCVBUFC=32000,                                        *
          RETRIES=(20,5,5),                                     *
          USSTAB=AUSSTAB,                                       *
          XID=NO,                                              *
          TYPE=NCP,                                           *
          DIAL=NO,                                             *
          LNCTL=SDLC,                                          *
          LEVEL2=ECLNARL2,                                     *
          LEVEL3=ECLNARL3,                                     *
          LEVEL5=NCP,                                          *
          TIMER=(ECLNART1,,ECLNART2,ECLNART3),                *
          XIO=(ECLNARXL,ECLNARXS,ECLNARXI,ECLNARXK),          *
          USERID=(5668854,ECLRBDT,NORECMS,,ECLNMVT),          *
          SPEED=9600,                                         *
          NPACOLL=NO,                                         *
          PUTYPE=1,                                           *
          PUDR=NO,                                           *
          COMPTAD=YES,                                        *
          COMPSWP=YES,                                       *
          COMPOWN=YES
*****
*      ADDRESS 1088:  NTRI PHYSICAL LINE - SUBAREA/PERIPHERAL  *
*****
*
A03TR88  LINE  ADDRESS=(1088,FULL),                             *
          INTERFACE=TR88,                                       *
          LOCADD=400000000331,                                   *
          PORTADD=1,                                           *
          TRSPEED=16,                                          *
          UACB=(X$P1AX,X$P1AR)
*
*      PU FOR SNA TRAFFIC
*
A03PU88  PU  ADDR=01,                                         *
          NETWORK=SNA,                                         *
          PUTYPE=1,                                           *
          INNPORT=YES

```

Figure 15-19 (Part 1 of 7). Example: Defining Internet Resources to NCP

## Sample Internet Resource Configuration and Definitions

```

*
*   PU FOR IP TRAFFIC
*
A03PU88A PU ADDR=02,
          ARPTAB=(1000,20,NOTCANON),
          NETWORK=IP,
          PUTYPE=1,
          INNPORT=YES
*
*****
*   ETHERNET ADAPTER INTERFACES
*****
*
A03ETH   GROUP ETHERNET=PHYSICAL,
          DIAL=NO,
          ISTATUS=ACTIVE,
          LNCTL=SDLC,
          VIRTUAL=NO
*****
A03E170  LINE ADDRESS=(1070,FULL),   * INTERFACE TO ETHERNET2 (ETH2) *
          ANS=CONT,
          FRAMECNT=(100000,5000),
          INTFACE=ETH2,
          LANTYPE=DYNAMIC
*
A03P170  PU ANS=CONT,
          ARPTAB=(2000,20),
          INNPORT=YES,
          PUTYPE=1,
          NPACOLL=NO,
          LPDA=BLOCK
*****
A03E171  LINE ADDRESS=(1071,FULL),   * INTERFACE TO ETHERNET3 (ETH3) *
          ANS=CONT,
          FRAMECNT=(100000,5000),
          INTFACE=ETH3,
          LANTYPE=DYNAMIC
*
A03P171  PU ANS=CONT,
          ARPTAB=(2000,20),
          INNPORT=YES,
          PUTYPE=1,
          NPACOLL=NO,
          LPDA=BLOCK
*

```

Figure 15-19 (Part 2 of 7). Example: Defining Internet Resources to NCP

## Sample Internet Resource Configuration and Definitions

```
*****
*   NCST IP INTERFACES   *
*****
*
A03NCSTG GROUP NCST=IP, LNCTL=SDLC, ANS=CONT, ISTATUS=ACTIVE, *
        VIRTUAL=YES
A03NCSTL LINE LINEFVT=CXSXFVT, *
        PUFVT=CXSXFVT, *
        LUFVT=(CXSXFVT, CXSXFVT), *
        LINECB=CXSXLNK
A03NCSTP PU PUTYPE=2, *
        PUCB=CXSP0000
*****
A03NCSA7 LU INTFACE=IPOWER, REMLU=SNALA17, * TO A17 *
        LUCB=(CXSL0000, CXSS0000), *
        LOCADDR=1
*****
A03NCS1P LU INTFACE=INTF2, REMLU=(B31NCS1P), * TO B31 *
        LUCB=(CXSL0001, CXSS0001), *
        LOCADDR=2
A03NCS1B LU INTFACE=INTF2, REMLU=(B31NCS1B), * TO B31 *
        LUCB=(CXSL0002, CXSS0002), *
        LOCADDR=3
*****
A03NCSA1 LU INTFACE=HOSTA01, REMLU=SNALA01, * TO A01 *
        LUCB=(CXSL0003, CXSS0003), *
        LOCADDR=4
        .
        .
        .
*****
*   IP ROUTING DEFINITIONS   *
*****
*
*   IP OWNER IDENTIFICATION
*
        IPOWER INTFACE=IPOWER, HOSTADDR=94.0.0.1, NUMROUTE=(25,25,25)
*
*   IP ADDRESSES ASSIGNED TO LOCAL NCP INTERFACES
*
        NCST INTERFACES
*
        IPLOCAL LADDR=94.0.0.99, INTFACE=IPOWER, METRIC=1, *
        P2PDEST=94.0.0.1, PROTOCOL=RIP
        IPLOCAL LADDR=95.0.0.99, INTFACE=HOSTA01, METRIC=1, *
        P2PDEST=95.0.0.1, PROTOCOL=RIP
        IPLOCAL LADDR=128.81.0.98, INTFACE=INTF2, METRIC=1, *
        P2PDEST=128.81.0.99, PROTOCOL=RIP
*
*   TOKEN RING INTERFACES
```

Figure 15-19 (Part 3 of 7). Example: Defining Internet Resources to NCP

## Sample Internet Resource Configuration and Definitions

```

*
      IPLOCAL LADDR=128.81.0.94,INTFACE=TR88,METRIC=1,
      PROTOCOL=RIP
*
*
      ETHERNET INTERFACE CHARACTERISTICS
*
      IPLOCAL LADDR=96.0.0.99,INTFACE=ETH2,METRIC=1,PROTOCOL=RIP
      IPLOCAL LADDR=128.81.0.96,INTFACE=ETH3,METRIC=1,PROTOCOL=RIP
*

*****
*****  B31NCP - NCP FOR SAMPLES NETWORK  SUBAREA = 31  *****
*****
          .
          .
          .
*****
*
      NCP TOKEN-RING INTERCONNECT PHYSICAL LINES
*****
*
B31INTR1  GROUP ADAPTER=TIC2,
            ANS=CONTINUE,
            ECLTYPE=(PHYSICAL,ANY),
            MAXTSL=4060,
            RCVBUFC=32000,
            RETRIES=(20,5,5),
            USSTAB=AUSSTAB,
            XID=NO,
            TYPE=NCP,
            DIAL=NO,
            LNCTL=SDLC,
            LEVEL2=ECLNARL2,
            LEVEL3=ECLNARL3,
            LEVEL5=NCP,
            TIMER=(ECLNART1,,ECLNART2,ECLNART3),
            XIO=(ECLNARXL,ECLNARXS,ECLNARXI,ECLNARXK),
            USERID=(5668854,ECLRBDT,NORECMS,,ECLNMVT),
            SPEED=9600,
            NPACOLL=NO,
            PUTYPE=1,
            PUDR=NO,
            COMPTAD=YES,
            COMPSWP=YES,
            COMPOWN=YES
*

```

Figure 15-19 (Part 4 of 7). Example: Defining Internet Resources to NCP

## Sample Internet Resource Configuration and Definitions

```
*****
*   ADDRESS 1092:  NTRI PHYSICAL LINE   *
*****
B31TR92  LINE ADDRESS=(1092,FULL),      *
          INTFACE=TR92,                 *
          LOCADD=400000017335,          *
          PORTADD=5,                    *
          TRSPEED=4,                   *
          UACB=(X$P1AX,X$P1AR)
*
*   PU FOR SNA TRAFFIC
*
B31PU92  PU ADDR=01,                    *
          NETWORK=SNA,                  *
          PUTYPE=1,                     *
          INNPORT=YES
*
*   PU FOR IP TRAFFIC
*
*
B31PU92A PU ADDR=02,                    *
          ARPTAB=(1000,20,NOTCANON),    *
          NETWORK=IP,                   *
          PUTYPE=1,                     *
          INNPORT=YES
*
*****
*   ETHERNET ADAPTER INTERFACES       *
*****
*
B31ETHG  GROUP DIAL=NO,                 *
          ETHERNET=PHYSICAL,            *
          ISTATUS=ACTIVE,               *
          LNCTL=SDLC,                   *
          VIRTUAL=NO
*
*****
*
B31E170  LINE ADDRESS=(1070,FULL),      *
          FRAMECNT=(100000,5000),      *
          INTFACE=ETH1,                 *
          LANTYPE=DYNAMIC,              *
          ANS=CONT
*
B31P170  PU ANS=CONT,                  *
          ARPTAB=(2000,20),             *
          INNPORT=YES,                  *
          PUTYPE=1,                     *
          NPACOLL=NO,                   *
          LPDA=BLOCK
```

Figure 15-19 (Part 5 of 7). Example: Defining Internet Resources to NCP

## Sample Internet Resource Configuration and Definitions

```

*
*****
*
B31E171  LINE ADDRESS=(1071,FULL),          *
          ANS=CONT,                          *
          FRAMECNT=(100000,5000),           *
          INTFACE=ETH3,                      *
          LANTYPE=DYNAMIC

*
B31P171  PU ANS=CONT,                        *
          ARPTAB=(2000,20),                  *
          INNPORT=YES,                       *
          PUTYPE=1,                           *
          NPACOLL=NO,                          *
          LPDA=BLOCK

*
*****
*   NCST INTERFACES                          *
*****
*
B31NCSTG GROUP NCST=IP, LNCTL=SDLC, ANS=CONT, ISTATUS=ACTIVE, *
          VIRTUAL=YES

*
B31NCSTL LINE LINEFVT=CXSFVT,                *
          PUFVT=CXSFVT,                       *
          LUFVT=(CXSFVT,CXSFVT),              *
          LINECB=CXSXLNK

*
B31NCSTP PU PUTYPE=2,                          *
          PUCB=CXSP0000

*****
B31NCSB1 LU INTFACE=IPOWER,REMLU=SNALB01,      * TO B01 *
          LUCB=(CXSL0000,CXSS0000),           *
          LOCADDR=1

*****
B31NCS1P LU INTFACE=INTF1,REMLU=(A03NCS1P),    * TO A03 *
          LUCB=(CXSL0001,CXSS0001),           *
          LOCADDR=2

B31NCS1B LU INTFACE=INTF1,REMLU=(A03NCS1B),    * TO A03 *
          LUCB=(CXSL0002,CXSS0002),           *
          LOCADDR=3

*****
B31NCS1C LU INTFACE=HOSTC01,REMLU=SNALC01,     * TO C01 *
          LUCB=(CXSL0003,CXSS0003),           *
          LOCADDR=4

          .
          .
          .
*

```

Figure 15-19 (Part 6 of 7). Example: Defining Internet Resources to NCP

## Sample Internet Resource Configuration and Definitions

```
*****
*   IP ROUTING DEFINITIONS   *
*****
*
*   IP OWNER IDENTIFICATION
*
*       IPOWNER INTERFACE=IPOWNER,HOSTADDR=191.91.1.1,          *
*           NUMROUTE=(25,25,25)
*
*   IP ADDRESSES ASSIGNED TO LOCAL NCP INTERFACES
*
*
*       NCST INTERFACES
*
*       IPLOCAL LADDR=191.91.1.99,INTERFACE=IPOWNER,METRIC=1,    *
*           P2PDEST=191.91.1.1,PROTOCOL=RIP
*       IPLOCAL LADDR=201.74.19.99,INTERFACE=HOSTC01,METRIC=1,   *
*           P2PDEST=201.74.19.1,PROTOCOL=RIP
*       IPLOCAL LADDR=128.81.0.99,INTERFACE=INTF1,METRIC=1,     *
*           P2PDEST=128.81.0.98,PROTOCOL=RIP
*
*       TOKEN RING INTERFACES
*
*       IPLOCAL LADDR=128.81.0.95,INTERFACE=TR92,METRIC=1,PROTOCOL=RIP
*
*       ETHERNET INTERFACE CHARACTERISTICS
*
*       IPLOCAL LADDR=191.91.2.99,INTERFACE=ETH1,METRIC=1,PROTOCOL=RIP
*       IPLOCAL LADDR=128.81.0.97,INTERFACE=ETH3,METRIC=1,PROTOCOL=RIP
*
```

Figure 15-19 (Part 7 of 7). Example: Defining Internet Resources to NCP





---

## Chapter 16. Frame-Relay Resources

This chapter describes NCP support for the frame-relay data communication protocol. It covers the following subjects:

- Introduction to frame relay
- Defining frame-relay physical lines
- Defining frame-relay logical subarea lines
- Defining frame-relay logical peripheral lines
- Defining frame handler connections
- 3746 Model 900 frame relay
- Defining NTRI attachments for frame relay
- Remote loading and activation over a frame-relay line
- Performance issues
- Sample frame-relay configurations and definitions.

---

### Introduction to Frame Relay

This section introduces frame relay and the NCP frame-relay functions, defines some important terms used in this chapter, and summarizes the general approach for defining NCP frame-relay connections.

### What Is Frame Relay?

Frame relay is a CCITT- and ANSI-standard communication protocol for high-speed local or wide area networks. A frame-relay network is composed of interconnected *frame-relay frame handlers (FRFHs)*, which switch frames through the network. At the boundary of the frame-relay network, frame-relay terminating equipment devices containing the *frame-relay terminating equipment (FRTE)* function transmit frames through the network to other frame-relay terminating equipment devices. Frames may travel directly from one terminating equipment device to another, or they may pass through one or more frame handlers.

Frame relay is a connection-oriented protocol; that is, routing through a frame-relay network is determined by the configuration of individual nodes. Frames do not contain origin or destination information. Instead, each frame handler simply switches frames between route segments, with no knowledge of the rest of the network.

**IP:** You can route IP datagrams over frame-relay attachments through NCP 3745 TSS and HPTSS adapters. NCP can communicate simultaneously using the same DLCI into a frame-relay network, using connection-oriented protocols, and with internet devices using a connectionless protocol. Refer to “Defining Frame-Relay Attachments for IP” on page 15-44 when defining internet support for frame relay.

**Token Ring:** You can switch frame-relay frames over a Token-Ring attached to NCP through NTRI. Refer to “Defining NTRI Attachments for a Frame-Relay Network” on page 16-63 to define frame-relay frame handler support for NTRI physical lines.

**ISDN:** You can send data across ISDN logical lines using the frame-relay protocol. Refer to Chapter 7, “Integrated Services Digital Network (ISDN) Resources” on page 7-1 when defining ISDN resources.

## Introduction to Frame Relay

NCP can function as both a frame-relay frame handler and a frame-relay terminating equipment device at the same time. When functioning as a frame-relay terminating equipment device, NCP can use frame relay to communicate with SNA subarea and peripheral nodes. When functioning as a frame handler, NCP can communicate with other CCITT- or ANSI-standard frame handlers or frame-relay terminating equipment devices. Figure 16-1 on page 16-3 shows three NCPs functioning as frame-relay terminating equipment devices and frame handlers in a sample frame-relay network.

Many public frame-relay service providers offer frame-relay networks to which you can connect frame-relay terminating equipment devices. Alternatively, you can use the NCP frame handler function to create your own private frame-relay network, or to create a hybrid network with a public provider.

**PVCs, Subports, and DLCIs:** Frame-relay terminating equipment devices are connected by logical paths called *permanent virtual circuits (PVCs)* that may pass through any number of frame handlers. PVCs are supported by *frame-relay physical lines* between network nodes. A single physical line can support multiple PVCs.

Each PVC is composed of one or more *PVC segments* between logical *frame-relay subports* in frame-relay network nodes. A PVC segment between subports in adjacent nodes is an *external PVC segment*, and a PVC segment between two subports in the same node is an *internal PVC segment*. A subport at the end of a PVC is a *terminating equipment subport (TESP)*. Because NCP supports multiplexing of PUs on a PVC, there may be multiple TESP per PVC. A subport between two PVC segments is a *frame handler subport (FHSP)*. In NCP, you can define sets of FHSPs to provide substitute internal PVC segments.

The attachment of a physical line to a node (a *frame-relay port*) can support multiple TESP and FHSPs. Figure 16-1 on page 16-3 shows PVC segments connecting TESP and FHSPs in three NCPs.

Frame-relay subports and PVC segments are identified by *data link connection identifiers (DLCIs)*. A DLCI is a number in the range X'00'–X'3FF' (0–1023 in decimal). DLCIs in the range X'10'–X'3DF' (16–991 in decimal) are available to users; the rest are reserved by frame-relay standards.

Each frame-relay subport in a single port has a unique DLCI. Each PVC segment is identified by the DLCIs of the subports at the ends of the PVC segment. Figure 16-2 on page 16-4 shows the DLCIs for the logical connections between NCPs functioning as frame handlers and terminating equipment in a frame-relay network.

**NCP Frame-Relay Connections:** The NCP frame handler and terminating equipment functions enable NCP to:

- Switch frames as part of a frame-relay or Token-Ring network
- Communicate with subarea and peripheral nodes

Figure 16-1 on page 16-3 illustrates these NCP frame-relay connections. The following list describes some of the connections shown in the figure.

Frame-relay subarea links

In NCP1, the terminating equipment function exchanges frames with NCP2 and NCP3 over frame-relay subarea links. The subarea link between NCP1

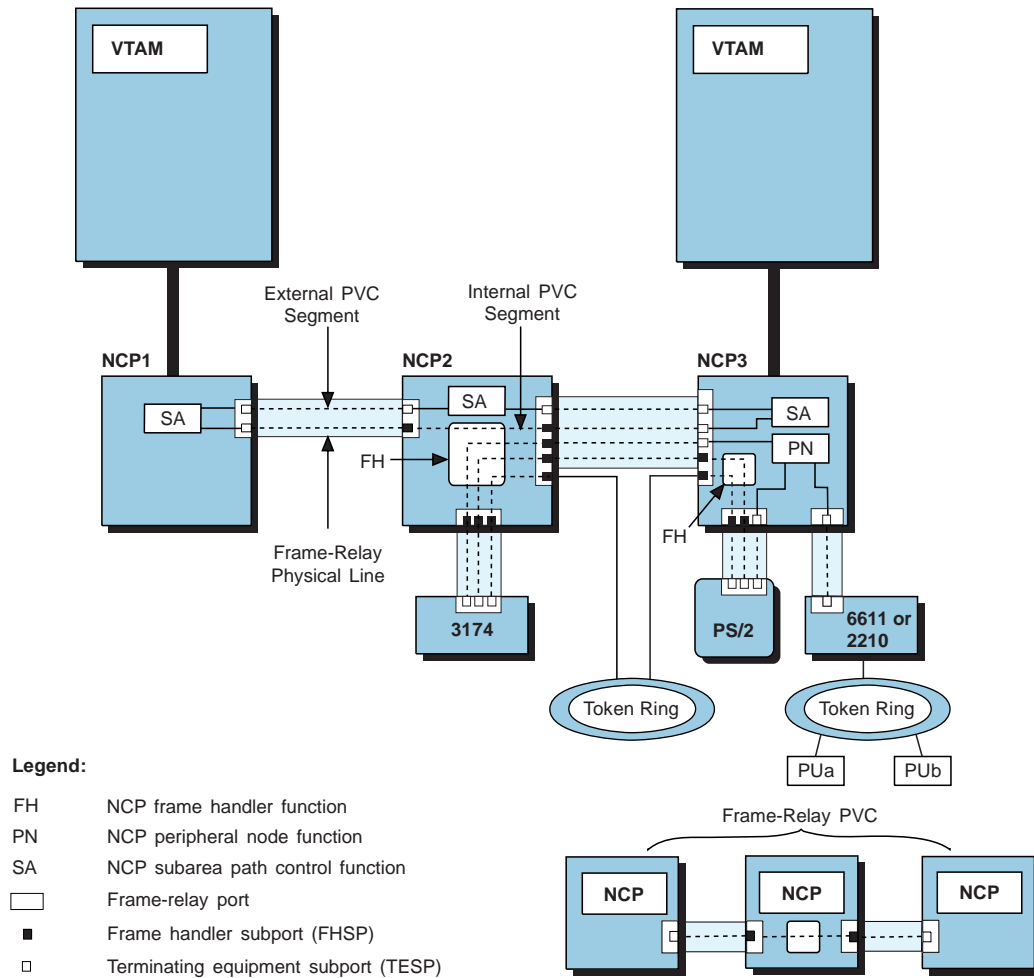

Figure 16-1. Frame-Relay Connections

and NCP3 passes through the frame handler function in NCP2. For more information, see “Defining Frame-Relay Logical Subarea Lines” on page 16-27.

#### Frame-relay peripheral links

In NCP3, the terminating equipment function exchanges frames with the PS/2 and both IBM 3174 Establishment Controllers over frame-relay peripheral links. The peripheral link between NCP3 and the IBM 3174 attached to NCP2 passes through the frame handler function in NCP2. The IBM 3174 appears as a peripheral device in NCP3's subarea even though it is physically attached to NCP2. For more information, see “Defining Frame-Relay Logical Peripheral Lines” on page 16-45.

#### Frame switching

In NCP2, the frame handler function switches frames between NCP1 and NCP3, and between an IBM 3174 and NCP3. For more information, see “Defining Frame Handler Connections” on page 16-57.

FHSP support is also provided over NTRI Token-Ring connections. Refer to “Defining NTRI Attachments for a Frame-Relay Network” on page 16-63 for information on defining this support.

## Introduction to Frame Relay

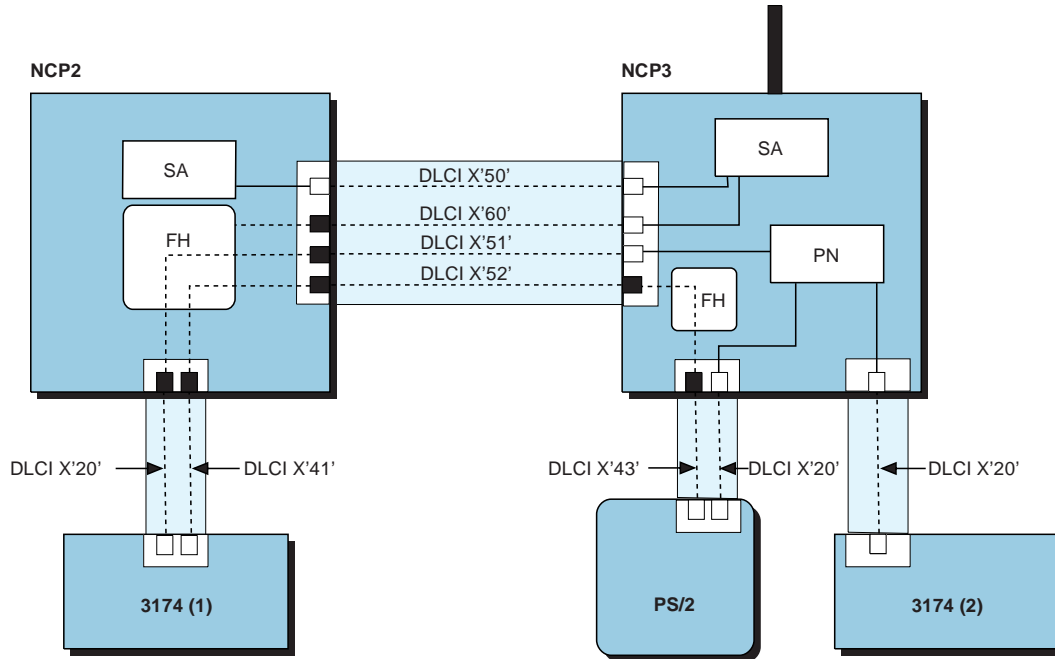

Figure 16-2. DLCIs for Frame-Relay Connections

**Advantages of Frame Relay:** Frame relay offers efficient data transfer at a wide range of speeds. Public frame-relay networks offer speeds from 56 Kbps to T1 and you can use lower or higher speeds in a private network. Frame relay provides guaranteed bandwidth for each PVC, and allows all PVCs to share unused bandwidth. In NCP, the total bandwidth is shared equally among the active PVCs unless you use the *priority* suboperand of the COMRATE keyword. (See the COMRATE keyword information under “Defining Frame Handler Connections” on page 16-57 for information about prioritizing PVCs.) The minimum guaranteed bandwidth can be calculated for each line that makes up the PVC by dividing the total number of PVCs on the line by the bandwidth of the line. Error correction is performed by terminating equipment, not by the frame handlers in the network, which further improves performance.

Frame relay is well suited to transporting multiple protocols. Because each frame-relay PVC has guaranteed bandwidth, when you isolate individual protocols on specific PVCs, each protocol is transported reliably without interference from others.

Frame relay can provide a cost-effective alternative to SDLC communication in a fully interconnected network. Because a frame-relay network can carry traffic for many different destinations on the same physical line, you may be able to consolidate lines and thereby reduce carrier and hardware costs. In addition, because NCP frame-relay functions are implemented entirely in software, no additional hardware is needed to use frame relay. To convert from SDLC to frame relay, you need only change your NCP generation definition. (For more information, see “Converting SDLC Subarea Links to Frame Relay” on page 16-38.) As with SDLC, frame-relay network management is provided by the NetView program.

## NCP Frame-Relay Terms

It will help you to know the following terms as you read how to define NCP frame-relay resources. These terms are presented in logical order, from general to specific, not in alphabetical order. Figure 16-1 on page 16-3 illustrates many of these terms.

### *Data terminal equipment (DTE)*

That part of a data station that serves as a data source, data sink, or both.

### *Frame-relay terminating equipment (FRTE)*

The function at the end of a PVC, which (1) adds frame-relay headers to data for another protocol and sends the frames to adjacent frame-relay nodes, and (2) receives frames from adjacent frame-relay nodes and removes the frame-relay headers. The frame-relay terminating equipment function accesses a PVC through a terminating equipment subport (TESP).

### *Frame-relay terminating equipment device*

A device that performs the frame-relay terminating equipment function.

### *Frame-relay frame handler (FRFH)*

The function in a frame-relay network node that switches frames along a PVC. A frame handler receives frames from an adjacent frame-relay node and forwards them to the next node on the PVC.

### *Frame-relay physical line*

The physical connection between two frame-relay nodes. A frame-relay physical line can simultaneously support PVC segments for both the frame handler and terminating equipment functions. However, if the frame-relay physical line is switched, it does not support frame handler or IP connections.

### *Data link connection identifier (DLCI)*

The numeric identifier of a frame-relay subport or PVC segment. Each subport in a single frame-relay port has a unique DLCI. Each PVC segment is identified by the DLCIs of the subports at the ends of the PVC segment.

### *Frame-relay port*

The attachment of a frame-relay physical line or NTRI frame handler logical line to a frame-relay device. A single frame-relay port supports multiple subports.

### *Frame-relay subport*

The point at which the frame handler or terminating equipment function in a frame-relay network node has access to a physical line; the end point of a PVC segment. A subport can support either the frame handler or terminating equipment function, but not both. Each subport in a single port is uniquely identified by its DLCI.

### *Terminating equipment subport (TESP)*

The end point of a PVC; the point at which terminating equipment has access to the PVC. An NCP TESP supports a subarea or peripheral logical line.

### *Frame handler subport (FHSP)*

The access point of a frame handler to a PVC segment. FHSPs function in pairs; frames enter the frame handler through one FHSP and exit through the other. In NCP, you define FHSPs in sets (FRSESETs) containing two primary FHSPs and an optional substitute FHSP for each primary.

### *Link-station subport*

The first subport defined on an NCP frame-relay physical line or NTRI frame handler logical line (the first PU definition statement under the LINE definition statement). When LMI is supported, NCP uses the SNA physical unit associated with the link-station subport to manage the line in the SNA environment.

### *LMI subport*

A frame-relay subport that exchanges line status information with adjacent nodes through local management interface protocol. Frame relay uses DLCI X'00' to exchange this information. In NCP, the LMI subport is the link-station subport for the frame-relay physical line or a NTRI frame handler logical lines. You do not need to define the connections between LMI subports.

**Note:** The LMI subport on NTRI frame handler connections specifies the one byte destination service access point and the six byte destination NCPs TIC address. This is not the case for frame-relay physical lines.

### *Permanent virtual circuit (PVC)*

The logical connection between two frame-relay terminating equipment devices, either directly or through one or more frame handlers. A PVC consists of one or more PVC segments.

### *PVC segment*

The logical connection between two adjacent subports, specifically:

- Between two TESP's in adjacent frame-relay terminating equipment devices
- Between a TESP and an FHSP in adjacent nodes
- Between two FHSP's in the same node or in adjacent nodes

A PVC segment between adjacent NCPs may pass through a frame-relay network.

### *External PVC segment*

A PVC segment between two subports in adjacent NCPs. The subports at the ends of an external PVC segment between two directly attached NCPs have the same DLCI. In NCP, you define an external PVC segment between two subports by assigning the same DLCI to those subports.

### *Internal PVC segment*

A PVC segment between two FHSPs in the same NCP. The subports at the ends of an internal PVC segment can have different DLCIs. In NCP, you define an internal PVC segment between two subports using the SUBPORTS keyword of the FRSESET definition statement. You can specify any combination of frame-relay physical line FHSPs and NTRI frame handler logical line FHSPs. FHSPs must be specified on different LINE definition statements.

### *Committed information rate (CIR)*

The information transfer rate for a particular PVC, which the network is committed to transfer under normal conditions.

### *Frame-relay logical line*

NCP's representation of an SNA logical connection over a PVC between NCP and a subarea or peripheral node. A frame-relay logical line is defined by a LINE definition statement, which also defines the associated TESP.

### *Frame-relay subarea link*

An SNA connection over a PVC between NCP and a subarea node (type 4 or type 5 physical unit).

*Frame-relay peripheral link*

An SNA connection over a PVC between NCP and a peripheral node (type 2 or type 2.1 physical unit).

*Consolidated Link Layer Management (CLLM)*

An optional frame-relay function used to provide management information to DTEs attaching to a network that supports CLLM.

## Definition Statements for Defining NCP Frame-Relay Resources

Use the following general approach to define NCP frame-relay connections. To define frame handler support for a NTRI-attached Token Ring, refer to “Defining NTRI Attachments for a Frame-Relay Network” on page 16-63. To route internet traffic to a frame-relay network, refer to “Defining Frame-Relay Attachments for IP” on page 15-44.

1. Code a GROUP definition statement to define a group of frame-relay physical lines. Each physical line can carry both frame handler and terminating equipment traffic. You can define a group of physical lines to support subarea links, peripheral links, or both.
  - Under the GROUP definition statement, code one or more LINE definition statements to define individual frame-relay physical lines.
  - Under each LINE definition statement, code a PU definition statement to define the link-station support. If you include LMI protocol support, this is the LMI support.
  - Between each LINE definition statement and the first PU definition statement, you can optionally code one or more DLCI statements to provide DLCI-specific parameters for DLCIs on the line.
  - If a nonswitched frame-relay physical line will carry traffic for the NCP frame handler function, code additional PU definition statements under the LINE definition statement to define FHSPs.
2. Code a GROUP definition statement to define a group of frame-relay logical lines. You can define a group of logical lines to support either subarea links or peripheral links, but not both.

Under the GROUP definition statement, code one or more of the following pairs:

- A LINE definition statement to define a logical subarea or peripheral line
  - A PU definition statement to define the TESP for the logical line.
3. If your NCP will include the frame handler function, code one or more FRSESET definition statements to define the internal PVC segments between FHSPs.

Sample definitions of individual NCP frame-relay resources appear at the end of each section in this chapter. Definitions of sample NCP frame-relay networks appear at the end of the chapter.

The operational characteristics of SNA resources in a frame-relay network are different from SNA resources defined as SDLC. For more information on these operational changes, see the *VTAM Operation* for your system.

---

### Defining Frame-Relay Physical Lines

An NCP frame-relay physical line is the physical connection between NCP and another frame-relay device. A single frame-relay physical line can carry traffic for both the frame handler and terminating equipment functions and can be used to route IP datagrams to destination internet hosts. This frame-relay physical line can be either nonswitched or switched. If it is switched, frame-handler subports are not supported, and IP subports must be coded on associated logical lines.

This section describes how to define frame-relay physical lines. For more information on defining the associated logical connections see the following sections:

- “Defining Frame-Relay Logical Subarea Lines” on page 16-27
- “Defining Frame-Relay Logical Peripheral Lines” on page 16-45
- “Defining Frame Handler Connections” on page 16-57.

When defining a frame handler logical line to switch frame-relay traffic over a NTRI-attached Token-Ring, or a frame-relay physical line to route internet traffic to a frame-relay network, refer to the following sections:

- “Defining NTRI Frame Handler Logical Links” on page 16-66
- “Defining Frame-Relay Attachments for IP” on page 15-44

The link-station support on each frame-relay physical line (the first physical unit defined on the physical line) can use the local management interface protocol to exchange line status information with adjacent nodes. When you define this capability for the link-station support, it is called the *LMI subport*. When a PVC status request is received from an adjacent node, the LMI support provides information about PVCs that have been added or deleted, and indicates whether existing PVCs are currently active. For more information on the LMI protocol, refer to *NCP and EP Reference*.

**Note:** Before data frames can be transmitted over a PVC, both end point TESP and all the physical lines and FHSPs that support the PVC must be active. If the PVC does not activate because one or more FHSPs are in a *contact pending* state, be sure that you have correctly defined the DLCIs for all subports and that all the resources for the PVC have been successfully activated. You can use NTuneMON to determine the status of each NCP TESP and FHSP. Refer to the *NTuneMON User's Guide* for more information.

### Defining Nonswitched Frame-Relay Physical Lines

Code the following definition statements and keywords to define a frame-relay physical line and an LMI subport.



OPTIONS	NEWDEFN
BUILD	BFRS
GROUP	FRELAY
LINE	ADDRESS CIR <sup>4</sup> CLLM <sup>4</sup> CLOCKNG DATABLK <sup>1</sup> FRRATES <sup>2</sup> HISPEED LOCADD <sup>3</sup> LSPRI MAXDLCI MAXFRAME MAXPU NPACOLL PORTADD RETRIES SPEED TITIMER TRANSBUF <sup>4</sup>
DLCI <sup>4</sup>	BALANCE CIR ID
PU	DYNWIND ERRORT LMI MAXDLCI NPACOLL SPOLL SRT TIMERS XMONLNK
<p><sup>1</sup> Supported starting with NCP V7R2.  <sup>2</sup> Supported starting with NCP V7R6.  <sup>3</sup> Supported starting with NCP V7R1.  <sup>4</sup> Supported starting with NCP V7R7.</p>	

## OPTIONS

NEWDEFN on the OPTIONS definition statement specifies whether the NCP generation process is to create a new NCP generation definition (NEWDEFN file). When you define NCP frame-relay resources, you need to create a NEWDEFN file. For more information, see “NDF-Generated Definition File” on page 2-1.

## Defining Frame-Relay Physical Lines

### BUILD

BFRS defines the size of the buffers in the NCP buffer pool and specifies the number of EP buffers to be allocated to the EP free buffer pool. The minimum buffer size allowed for supporting 3745 frame-relay boundary access node (BAN) connections, is 100. The minimum buffers size is not affected by 3746 Model 900 BAN support.

### GROUP

FRELAY on the GROUP definition statement defines a frame-relay line group. Define each physical line within the group by coding a LINE and a PU definition statement.

Code FRELAY=(PHYSICAL,SUBAREA) for this line group or for a line if it does not support SNA peripheral FRTE resources. This means that you should code the SUBAREA suboperand if the line supports subarea connections or non-SNA FRTE resources. (If you code the ANY or the PERIPHERAL suboperand for a physical line that is directly attached to a non-SNA FRTE that supports only the user-to-network (UNI) LMI protocol, you can waste NCP cycles and link bandwidth. Use the SUBAREA suboperand in this case.)

Code the suboperands of the FRELAY keyword as shown in Table 16-1 to specify which types of logical link the physical line is to support.

Table 16-1. Values for FRELAY on the GROUP Definition Statement

FRELAY Value	Provides Support for			Comments
	Subarea Links	Peripheral Links	FHSPs	
(PHYSICAL,SUBAREA)	Yes	No	Yes	
(PHYSICAL,PERIPHERAL)	No	Yes	Yes	
(PHYSICAL,ANY)	Yes	Yes	Yes	Valid only for HPTSS and 3746 Model 900 lines. See the note <sup>1</sup> regarding HPTSS microcode levels.
PHYSICAL	Yes	See Comments column	Yes	For low-speed lines, the second suboperand defaults to SUBAREA. This means there are no peripheral links. For HPTSS and 3746 Model 900 lines, the second suboperand defaults to ANY. This means that both subarea and peripheral links are supported.

<sup>1</sup>**HPTSS Microcode Levels:** For HPTSS lines, to code FRELAY=(PHYSICAL,ANY), the HPTSS adapter in your controller must have one of the following microcode levels:

- C38006 for the IBM 3745 Models 130, 150, 160, and 170
- C37967 for the IBM 3745 Models 210, 310, 410, and 610
- D39888 for the IBM 3745 Models 21A, 31A, 41A, and 61A
- D400002 for the IBM 3745 Model 17A.

### LINE

ADDRESS on the LINE definition statement specifies the relative line number of the physical line and whether the line is half-duplex or duplex. Frame-relay physical lines are duplex, so code ADDRESS=(*line-number*,FULL). To run at T1 line speeds, use an HPTSS line adapter address or a high speed port on a 3746 Model 900 CLP.

CIR specifies whether the CIR algorithms should be used for bandwidth management.

**3745 Frame Relay:** The CIR keyword is not valid.

CLLM specifies whether Consolidated Link Layer Management should be used. CLLM=YES is valid only if CIR=YES.

**3745 Frame Relay:** The CLLM keyword is not valid.

CLOCKNG specifies whether the modem or the communication scanner for the line is to provide clocking.

DATABLK specifies the minimum transmission bandwidth, in bytes, that can be allocated to a resource or to a protocol.

**3745:** DATABLK is used with the *priority* suboperands of the COMRATE and FRRATES keywords to determine the relative priority among resources and supported protocols, respectively. The value of the *priority* suboperand is multiplied by the value of DATABLK to determine the guaranteed minimum number of bytes that a resource or protocol can transmit before a different resource or protocol must be given a transmission opportunity.

**3746 Model 900:** DATABLK is also used with the *Bc* and *Be* parameters of the DLCI statement's CIR keyword to determine the committed burst size and the excess burst size.

FRRATES on the 3745 frame-relay physical LINE definition statement specifies the relative priorities for:

- SNA protocol traffic
- Internet Protocol traffic
- Frame handler protocol traffic

when any of these protocols is supported by the physical line. Code  $FRRATES=(sna\_priority,ip\_priority,fh\_priority)$ . The value of each protocol's *priority* suboperand is multiplied by the value of the DATABLK keyword on the physical LINE definition statement to determine the guaranteed minimum number of bytes provided for that protocol, for the transmission of associated traffic, before a different protocol is given a transmission opportunity.

The relative priority of a protocol supported by a 3745 frame-relay physical line can be determined as a fraction of the total available transmission opportunity dispersed to all supported protocols. This fraction is calculated by dividing the protocol's *priority* suboperand value by the sum of the *priority* values of all **supported** protocols on the physical line.

$$\frac{\text{Protocol's } priority \text{ value}}{\text{Sum of } priority \text{ values of all protocols supported by the physical line}}$$

For example, if traffic for all three protocols (SNA, IP, and frame handler) is supported by the physical line, the SNA protocol's transmission fraction is determined like this:

$$\frac{PRIORITY_{SNA}}{PRIORITY_{SNA} + PRIORITY_{IP} + PRIORITY_{FH}}$$

Where PRIORITY = the value of the respective protocol's *priority* suboperand of the FRRATES keyword.

**3746 Model 900:** The FRRATES keyword is not valid.

## Defining Frame-Relay Physical Lines

HISPEED determines the speed to be used on TSS lines. Code HISPEED=YES to define TSS lines operating at 144 Kbps or greater.

LOCADD specifies the NCP virtual MAC address used by remote BAN routers for frame-relay peripheral connections. This MAC address is something referred to as the BAN identifier in the BAN router. The value specified for LOCADD must be the same in all routers that will have BAN connections to NCP for all DLCIs over this physical line. The value used for the NCP virtual MAC address should not match the MAC address of a LAN-attached station within your network. The MAC address does not have to be unique across your frame-relay interfaces.

LSPRI specifies whether NCP is to use transmission priority to determine the order in which PIUs are sent to the physical unit over a logical peripheral line. For frame-relay physical lines that support logical peripheral lines, you can specify either LSPRI=NO (the default) or LSPRI=PU.

MAXDLCI on the LINE definition statement defines the maximum number of DLCIs for the frame-relay interface if LMI is not supported. The value you code should equal or exceed the expected number of DLCIs. If LMI is supported, the maximum DLCI is the smaller of:

- The largest DLCI allowed by the MAXDLCI keyword
- The value of the following expression (converted to hexadecimal):

$$((maxframe - fixed) \div 5) + 15$$

where:

*maxframe* is the value of MAXFRAME for this line.

*fixed* is 17 when LMI=CCITT or LMI=CCITT-NUI.

*fixed* is 18 when LMI=ANSI or LMI=ANSI-NUI.

MAXFRAME defines the maximum size frame to be transmitted through the frame-relay network. The value you code should equal or exceed the maximum possible frame size. Specify the same value for MAXFRAME for all physical lines that support a PVC through any number of NCPs. See DLCI on page 16-32 for information about the relationship between MAXFRAME and DLCI on the PU definition statement.

MAXPU defines the maximum number of FHSP physical units (including the link-station support) to be supported on the link.

NPACOLL specifies whether the network performance analyzer is to collect performance data for the line. Frame-relay physical lines and stations use extended format COLLECT request/response units; therefore, if EXT is not coded, NDF adds it.

PORTADD identifies to VTAM the port numbers of the frame-relay physical lines. PORTADD values of 0–99 are supported for 3745 frame-relay lines. PORTADD values of 0–254 are supported for 3746 Model 900 frame-relay lines. For 3745 frame relay, up to 155 lines can be defined in your generation definition without the PORTADD keyword. However, if additional lines are needed, PORTADD must be used.

**3746 Model 900 Frame-Relay Lines:** PORTADD is required. The PORTADD values must be unique for each 3746 Model 900 frame-relay adapter, but

they can be the same as values coded for 3746 Model 900 Token-Ring or frame-relay physical lines that are not attached to the 3746 Model 900.

See “Defining Peripheral Device Addresses to VTAM” on page 16-51 for more information about correlating VTAM switched major node addressing information with NCP resources.

RETRIES specifies the maximum number of consecutive errors between 100 milli-second (ms) periods allowed before NCP brings down the physical line and its associated logical, FHSP, and IP resources. Code only the *m* suboperand. Code a value of NONE or 0 to indicate that NCP should **not** bring down the physical line based on consecutive errors.

SPEED sets the data rate for a line. SPEED also provides a value for NPM to use when computing line utilization statistics.

**3746 Model 900 Frame-Relay Physical Lines:** You must code the SPEED keyword.

**APPN HPR:** NCP uses the value of the SPEED keyword to determine the rate of flow for APPN HPR data on frame-relay physical peripheral lines. Code the SPEED keyword for frame-relay physical peripheral lines that support APPN HPR data to ensure that the APPN HPR flow control mechanism works correctly.

TITIMER defines the IEEE 802.2 LLC inactivity timer (TI) value for all SNA logical subarea and peripheral connections (**not** frame-relay PVCs) on the physical line. The inactivity timer determines how long NCP will wait without receiving a frame from the adjacent device. If NCP has not received a frame from the adjacent device by the time the inactivity timer expires, NCP polls the device to determine whether it is still active. NCP starts the inactivity timer when the link to the device is activated, and resets the timer whenever a frame is received from the device. The default value of 60 seconds is suitable for most applications. Larger values can cause a delay in detecting inactive devices, and smaller values can cause excessive polling.

TRANSBUF defines the maximum number of frames that will be queued for a TSS or HPTSS adapter awaiting transmission over a 3745 frame-relay physical line. With a smaller queue, frames have less latency time before being transmitted. In addition, a smaller queue allows various priority mechanisms (for example, COMRATE) to operate more effectively. Conversely, a larger queue yields better line utilization.

**HPTSS Adapters:** If the microcode does not support subarea and peripheral connections on a single line, the defined keyword value is ignored by NCP. Instead, NCP queues only one frame for the adapter.

## DLCI

Between the LINE definition statement and the first PU definition statement, you can code one or more DLCI statements to control DLCI-specific parameters for any of the data link connection identifiers (DLCIs) supported by the line.

ID on the DLCI statement specifies the DLCI or range of DLCIs to which the next keyword applies.

CIR on the DLCI statement specifies the CIR parameters for the identified DLCIs.

**3745 Frame Relay:** The CIR keyword is not valid.

BALANCE on the DLCI statement specifies the *connection balancing factor* for the identified DLCI(s).

**DLCI Connection Balancing:** DLCI connection balancing distributes incoming call requests, initiated by downstream peripheral devices, across all DLCIs configured with the same Boundary Access Node (BAN) DLCI MAC address as specified in the remote BAN router(s). See “Frame-Relay Boundary Access Node (BAN)” on page 16-45 for more information on frame-relay BAN.

For each DLCI in which connection balancing will be performed, the number of peripheral BAN connections supported by the DLCI is tracked. Based on this count and the DLCI’s balancing factor, NCP delays sending a response to route determination frames that are *Source Route Bridged* (SRB) or *Data Link Switched* (DLSw) by the remote BAN router. Because the DLCI carrying the first reply will receive the subsequent connection request, delaying sending a response allows the BAN connection to establish over an alternate DLCI.

**Note:** DLCI connection balancing will not balance Ethernet connections that are *Source Route Transparent Bridged* (SRTB) by the remote BAN router.

To prevent a potential broadcast storm of retransmitted route determination frames by the peripheral devices, the delay time is restricted to a 0.9-second maximum.

Because DLCI connection balancing is performed independently for each DLCI, there is no limit to the number of DLCIs for which the balancing scheme can be performed. In addition, these DLCIs do not have to be supported by the same frame-relay physical line or to originate from the same remote BAN router. They can be supported by parallel links from different routers, but the links must have comparable line speeds. Furthermore, in order for the balancing mechanism to function properly, all DLCIs configured with the same BAN DLCI MAC address must have a balancing factor specified.

**Linear Connection Balancing (3745 and 3746 Model 900):** When you specify a numerical value for BALANCE, a fixed balancing algorithm is used. Based on the balancing factor and the DLCI’s number of supported connections, the algorithm uses the following expression to determine the time delay for responding to route discovery frames:

$$\text{Delay} = (\text{number\_of\_connections} / (\text{balancing\_factor} * 16)) * 0.1 \text{ seconds}$$

In effect,  $(\text{balancing\_factor} * 16)$  determines the connection granularity for each DLCI. A balancing factor of 1 equates to a 16 connection granularity. After a DLCI supports 16 peripheral BAN connections, NCP introduces a 0.1-second delay before sending a response to any route determination frames. This allows other DLCIs configured with the same BAN DLCI MAC address and having fewer connections to honor the incoming call request. Furthermore, this delay increases to a 0.2-second delay after 32 peripheral BAN connections are supported.

In contrast, a balancing factor of 32 equates to a 512 connection granularity. After a DLCI supports 512 peripheral BAN connections, NCP introduces a 0.1-second delay before sending a response to any route determination frames. After 1024 peripheral BAN connections are supported, NCP introduces a 0.2-second delay. NCP continues to increase the delay by 0.1-second increments until a 0.9-second delay is reached.

You can determine an appropriate balancing factor by dividing the total number of DSPUs to be supported by the frame-relay BAN environment by 160 and rounding to the nearest integer from 1 through 32.

**Auto-Adaptive Connection Balancing (3746 Model 900 only):** When you specify `BALANCE=AUTO`, a logarithmic balancing algorithm is used. The algorithm dynamically adjusts the time delay, for responding to route discovery frames, as new connections are established.

When the DLCI supports a small number of connections, the time delay increases more quickly as new connections are added. Conversely, when a large number of connections is supported, the time delay increases gradually as connections are established.

Unlike the fixed balancing algorithm, you are not required to specify an appropriate numerical balancing factor for all DLCIs configured with the same BAN DLCI MAC address that provide the auto-adaptive balancing function.

Refer to the *3745 Communications Controller Model A, 3746 Nways Multi-protocol Controller Models 900 and 950 Planning Series: Serial Line Adapters, GA27-4235*, for more information about the Model 900 auto-adaptive balancing processing.

### PU

The first PU definition statement under the LINE definition statement for a frame-relay physical line defines the link-station subport. This subport can use the LMI protocol to exchange line status information with adjacent nodes. For nonswitched lines only, subsequent PU definition statements define either FHSPs or IPSPs. See "Defining Frame Handler Connections" on page 16-57 for more information on defining FHSPs and the internal PVC segments between them. See "Defining Frame-Relay Attachments for IP" on page 15-44 for more information on defining IPSPs.

**Note:** The name of the PU definition statement for the link-station subport is used as the value for `PHYSRSC` on the `GROUP` definition statement for the logical lines supported by the physical line. This associates the logical lines with the physical line.

`DYNWIND` on the PU definition statement defines the dynamic characteristics of the frame transmission window for logical peripheral physical units associated with this physical line, via `PHYSRSC`, when the `DYNWIND` values are not coded in the VTAM switched major node. This is valid only for LMI PUs. This window is the number of frames NCP can send before waiting for an acknowledgment. The maximum window size for each logical connection is defined by `MAXOUT` on the PU definition statement.

`DYNWIND` defines the following values:

## Defining Frame-Relay Physical Lines

### *nw*

The rate at which the window size increases after it has been decreased by frame loss or congestion. This is the IEEE 802.2 LLC *Nw* parameter. After NCP has decreased the transmission window size, NCP increases the window size after *Nw* frames transmitted by NCP are received and acknowledged by the adjacent device. This process continues until the window size reaches its maximum.

### *dw, dwc, and mww*

The rates at which the window size decreases when frame loss or congestion occurs, and the minimum size for the transmission window. The defaults for these values cause NCP to decrease the window size to 1 immediately, in conformance with the IEEE 802.2 logical link control (LLC) protocol. You can increase the transmission rate by coding values that cause the window size to decrease more slowly or by coding a value that limits the reduction of the window size. See the description of the DYNWIND keyword on the PU statement in *NCP, SSP, and EP Resource Definition Reference* for a list of valid *dw*, *dwc*, and *mww* values and their effects on the working window.

### *dwdmax*

The upper limit for the time delay that NCP initiates before transmitting the next I-frame for a 3745 FRTE station experiencing congestion. NCP initiates the time delay if congestion continues while a station's working transmit window is equal to 1. When an FRTE station's DLCI is assigned a low committed information rate (CIR) on a high speed link, the dynamic window algorithm might not prevent the station from experiencing congestion even with a working transmit window of 1. When congestion is detected in this case, NCP introduces an initial 100 millisecond (ms) delay between I-frame transmissions. NCP increases the time delay by 100 ms increments to the upper limit (*dwdmax*) while congestion occurs. Conversely, when congestion clears, NCP decreases the time delay by 100 ms decrements.

### *twcuse*

Whether or not NCP ignores any subsequent BECN for the window congestion time of 100 ms after receiving the initial BECN. The *twcuse* suboperand is intended to prevent NCP 3745 FRTE stations from overreacting to mild congestion. It applies only when the working transmit window is greater than 1.

ERRORT on the PU definition statement defines the error threshold at which NCP terminates communication with an adjacent frame-relay node. The threshold is the number of errors out of a number of consecutive events. Code ERRORT and TIMERS on the PU definition statement for the link-station subport to monitor the integrity of the physical line. ERRORT is not valid if you specify LMI=NO for the link-station subport.

LMI specifies whether the link-station subport is to support the LMI protocol, and if so, the LMI protocol standard that NCP is to use. If you code LMI=ANSI or LMI=CCITT, NCP determines the level of LMI support required to communicate with the adjacent frame-relay node during activation of the LMI subport. The level of support used by NCP can be one of the following:

- No LMI support
- Request LMI status only: UNI (user-to-network interface)



- Respond to LMI status requests only: NUI (network-to-user interface)
- Bidirectional support to request LMI status and respond to LMI status requests: NNI (network-to-network interface)

The LMI standard used by the frame-relay network node at each end of a physical connection can be ANSI, the United States standard, or CCITT, the international standard. Code the first suboperand to indicate which standard is to be used by your NCP. Use the same LMI standard at both ends of a connection; mismatched LMI standards can cause an interruption in LMI processing and can prevent activation of a physical link.

When you code the LMI keyword and there is an NCP at each end of a physical point-to-point connection, you can invoke echo-detection support to prevent processing of an echoed LMI frame when the physical route is established over a satellite link. An NCP at either end of a satellite connection can detect and discard a received frame that is an echo of a prior transmitted frame. If you are using a satellite link and you do not assign a primary/secondary relationship, then if an LMI frame is echoed, it will be processed incorrectly. Incorrect status changes of frame-relay resources may occur or an incorrect level of LMI support may be negotiated over that frame-relay physical line. Refer to *NCP and EP Reference* for more information about echo-detection support.

**Note:** The echo detection mode for an LMI link-station subport at each end of a physical connection must be defined to be complementary. If you define the local link-station subport as the primary, define the adjacent link-station subport as the secondary.

You can code LMI=NO, but this is not recommended unless the adjacent FHSP or TESP does not support the LMI protocol. To ensure accurate PVC end-to-end status with a frame-relay network, define LMI support for all link-station subports on the PVC. If you code LMI=NO, all DLCIs associated with the physical port are considered active by NCP once the link-station subport is activated. Transmitted frames can be lost or discarded since NCP receives no status information indicating whether a PVC is considered active by the destination frame-relay terminating equipment device. Refer to *NCP, SSP, and EP Resource Definition Reference* for specific information about coding the LMI keyword. Detailed information about the LMI protocol and link integrity verification can also be found in *NCP and EP Reference*.

**Note:** NCP does not support substitute FHSPs on a physical line that does not support the LMI protocol.

MAXDLCI on the LMI subport PU definition statement defines the maximum number of DLCIs for the frame-relay interface if LMI is not supported. The value you code should equal or exceed the expected number of DLCIs. If LMI is supported, the maximum DLCI is the smaller of:

- The largest DLCI allowed by the MAXDLCI keyword
- The value of the following expression (converted to hexadecimal):

$$((maxframe - fixed) \div 5) + 15$$

where:

*maxframe* is the value of MAXFRAME for this line.

*fixed* is 17 when LMI=CCITT or LMI=CCITT-NUI.

## Defining Frame-Relay Physical Lines

*fixed* is 18 when LMI=ANSI or LMI=ANSI-NUI.

NPACOLL specifies whether the network performance analyzer is to collect performance data for the physical unit. Frame-relay physical lines and stations use extended format COLLECT request/response units; therefore, if EXT is not coded, NDF adds it.

SROLL defines the frequency at which LMI full status requests are sent to the adjacent frame-relay node by the LMI subport. SROLL is not valid if you specify LMI=NO for the link-station subport.

SRT defines reporting thresholds for the number of error retries and the total number of transmissions. When either of these thresholds is reached, NCP builds an error event record using RECMS. The threshold is determined by the total number of LMI frames, FHSP frames, and TESP frames sent over the physical port.

**3746 Model 900:** SRT is ignored.

TIMERS defines the LMI T391 and T392 intervals. The T391 interval is the interval between transmissions of LMI Link Integrity Verification (LIV) status enquiry messages to the adjacent node. The T392 interval is the interval in which an LMI status enquiry message must be received before the interval is considered an error interval. Code TIMERS and ERRORT on the PU definition statement for the link-station subport to monitor the integrity of the physical line. TIMERS is not valid if you specify LMI=NO for the link-station subport.

### Notes:

1. NCP may lose contact with an adjacent controller when the adjacent controller is accessing its disk during a load or a dump over the link. To prevent this, code TIMERS and ERRORT values such that the total retry time before an LMI threshold error occurs is at least 3 minutes.
2. When many DLCIs are in use on a frame-relay physical line that uses LMI, the T391 and T392 intervals must accommodate delays due to low line speeds. Since LMI frames (DLCI X'00') have the same transmission priority as frames for other DLCIs, an LMI status enquiry message may be queued for transmission behind many other frames. With a low-speed line, the delay may be longer than the default T391 interval. In this situation, use a longer T391 interval for both NCP and the adjacent node.

XMONLNK specifies whether a link address is to be monitored for an Activate Physical command when NCP is not in session with an SSCP on this line. If you code XMONLNK=YES for an LMI subport, also code MONLINK=YES on the corresponding logical LINE definition statement. If you code XMONLNK only, the link activation will fail.

## Defining Switched Frame-Relay Physical Lines

Switched frame-relay physical lines are available for 3745 beginning in NCP V7R6 and for 3746 Model 900 beginning in NCP V7R7. This type of line allows you to define frame-relay physical interfaces to back up frame-relay peripheral connections with devices such as the IBM 2210 Multiprotocol Router. NCP supports both CALLIN and CALLOUT for these switched frame-relay physical interfaces. Switched frame-relay interfaces for subarea connections are also supported.

Frame handler supports are **not** supported for switched frame-relay physical lines. In addition, IP supports are **not** supported for 3746 Model 900 switched frame-relay physical lines.

Code the following definition statements and keywords to define a switched frame-relay physical line. *Code these definition statements and keywords in addition to the definition statements and keywords found in “Defining Nonswitched Frame-Relay Physical Lines” on page 16-8.*

GROUP	DIAL <sup>1</sup>
LINE	ANSTONE AUTO ID REDIAL RING V25BIS

<sup>1</sup> Supported starting in NCP V7R6.

**Note:** For 3745 switched frame-relay physical lines, IP supports are defined on separate logical lines. See “Defining Frame-Relay Attachments for IP” on page 15-44 for more information on defining IPSPs.

### GROUP

DIAL on the GROUP definition statement specifies whether the 3745 frame-relay line requires the switched line control procedures that are available for frame relay beginning with NCP V7R6. Code DIAL=YES for a switched line. Figure 16-43 on page 16-93 and Figure 16-44 on page 16-93 show a sample generation definition for a switched frame-relay physical line.

### LINE

The following LINE keywords apply only if DIAL=YES on the GROUP definition statement.

ANSTONE on the LINE definition statement specifies whether NCP sends an answer tone to the calling device to signify completion of the link connection. Most modems in the United States and Canada provide this answer tone; therefore, you do not usually have to specify that NCP sends it. If you are not sure that your modem provides this tone, ask the supplier or installer of the modem.

AUTO on the LINE definition statement specifies whether a logical automatic calling unit (ACU) is installed on the line, or it specifies whether automatic calling is to be used for V.25 bis protocol. Code AUTO=YES for V.25 bis even though an automatic calling unit (ACU) is not connected. See “V.25 Bis” on page 5-7 for more information about V.25 bis modems and connections.

ID on the LINE definition statement is required when DIAL=YES on the GROUP statement. ID provides the XID data necessary for VTAM to identify the station because no actual XID exchange occurs during activation of a frame-relay physical line. Be sure that the number you choose for ID is unique within the network. ID must correspond to the IDNUM and IDBLK keywords of the PU definition statement in the VTAM switched major node definition. Read *VTAM Resource Definition Reference* for information on coding VTAM switched major nodes.

## Defining Frame-Relay Physical Lines

REDIAL on the LINE definition statement defines the maximum number of dialing operations NCP is to perform to reach a device over a switched link. REDIAL also defines the duration of the pause between dialing operations.

RING specifies whether the modem has the ring-indicator interface. If you are not sure whether your modem has this feature, ask the supplier or installer of the modem. Defining this feature for a modem that does not have it can result in an unnecessary delay in establishing the connection. Also, outgoing calls cannot be made if you specify that the modem has this feature.

**Note:** RING does not apply to networks in the United States or Canada.

V25BIS on the LINE definition statement defines modem support for the V.25 bis protocol and identifies the line control protocol for the dial operation (SDLC or start-stop). If the interface is V25BIS, then you must code V25BIS=(YES,DLSS) or V25BIS=(YES,DLSDLC). (For 3746 Model 900 switched frame relay, V25BIS=(YES,DLSDLC) is the only valid value.)

## PU

The PU definition statement under the LINE definition statement defines the link-station support. This support can use the LMI protocol to exchange line status information with adjacent nodes. This support is the only PU definition allowed on a switched frame-relay physical line.

The LMI keyword on the PU statement enables you to request that the frame-relay interface use only the Network-to-User Interface by adding -NUI to the end of the standard suboperand (LMI=CCITT-NUI or LMI=ANSI-NUI). In this case, NCP performs no discovery of the LMI support to use.

**Attention:** If the adjacent frame relay device is also only NUI-capable, specifying -NUI will result in the frame-relay interface remaining in an activation pending state.

Use of -NUI speeds activation of the frame-relay interface when the adjacent frame-relay device is only UNI- (User-to-Network interface) capable by eliminating the time (default of 40 seconds) it takes to determine that the adjacent device is UNI-only. This might be a consideration for switched frame-relay ISDN interfaces that might be used for only a short duration.

See discussion of the LMI keyword on page 16-16 for more information about LMI.

### Sample Definition of a Switched Frame-Relay Physical Line

See "Switched Frame-Relay Physical Line" on page 16-93.

## NDF-Added Keywords for Frame-Relay Physical Lines

When you define frame-relay physical lines, NDF adds the following keywords to your generation definition if you do not code them.

```

GROUP DIAL=NO,
      LNCTL=SDLC,
      NPACOLL=(YES,EXTENDED), 1
      PUTYPE=1,
      TYPE=NCP
PU    ANS=CONTINUE,
      INNPORT=YES, 2
      NPACOLL=(YES,EXTENDED) 1

1 Added if NPA=YES on the BUILD definition statement.
2 Not added when FRELAY=(PHYSICAL,PERIPHERAL) on the GROUP definition
  statement.
```

Figure 16-3. NDF-Added Keywords for Frame-Relay Physical Lines

### Sample Definition of a Frame-Relay Physical Line

Figure 16-4 shows how to define a frame-relay physical line that supports FHSP connections, subarea links, and peripheral links. An HPTSS line or a 3746 Model 900 line is required to support both subarea and peripheral links. The PU definition statement defines the LMI support.

```

C04FRGP1 GROUP FRELAY=(PHYSICAL,ANY) X
              ISTATUS=ACTIVE,      VTAM-only keyword X
              TYPE=NCP              Automatically added by NDF
*
*****
* FRAME RELAY PHYSICAL LINE 1028 - FULL DUPLEX HPTSS *
*****
C04F1028 LINE ADDRESS=(1028,FULL), *
              MAXFRAME=2106, *
              CLOCKNG=EXT, *
              NRZI=NO,          The default is NO *
              SPEED=1544000, *
              DATABLK=4096
C04P1028 PU   LMI=CCITT,          LMI support *
              SPOLL=6, *
              ERRORT=(3,4), *
              TIMERS=(10,15)
```

Figure 16-4. Example: Defining a Frame-Relay HPTSS Physical Line

Figure 16-5 on page 16-22 shows how to define a 3746 Model 900 frame-relay physical line that supports FHSP connections, subarea links, and peripheral links. The value of the ADDRESS keyword must be between 2112 and 2750, inclusive, and the PORTADD keyword is required.

## Defining Frame-Relay Physical Lines

```
C04FRGP1 GROUP FRELAY=(PHYSICAL,ANY) The default is ANY X
                ISTATUS=ACTIVE,      VTAM-only keyword X
                TYPE=NCP              Automatically added by NDF
*
*****
* FRAME RELAY PHYSICAL LINE 2176 - FULL DUPLEX CSS
*****
C04F2176 LINE ADDRESS=(2176,FULL), *
              MAXFRAME=2106, *
              CLOCKNG=EXT, *
              NRZI=NO, The default is NO *
              PORTADD=10, Required keyword for CSS *
              SPEED=1544000, *
              DATABLK=4096 *
C04P2176 PU LMI=CCITT, LMI subport *
            SPOLL=6, *
            ERRORT=(3,4), *
            TIMERS=(10,15) *
```

Figure 16-5. Example: Defining a Frame-Relay 3746 Model 900 Physical Line

See “3746 Model 900 Frame Relay” on page 16-72 for more information about 3746 Model 900 frame-relay support.

## Defining Automatic Frame-Relay Backup over an ISDN

Starting with V7R5, NCP supports the definition of a backup ISDN line for a 3746 Model 900 nonswitched frame-relay physical line attached to the same 3746 Model 900. If the frame-relay line fails, the 3746 Model 900 CSS reroutes the frame relay traffic over the specified ISDN line.

Backup of a frame-relay line over an ISDN provides the following benefits:

- Backup is automatic, requiring neither manual intervention nor a C-list to operate.
- Backup is non-disruptive. The frame-relay terminating equipment recovers any lost frames. Frame-relay resources are not impacted. A resource can be activated or deactivated on the failed frame-relay line.

### Configuration for Backup

Frame-relay backup is available for frame-relay private, point-to-point connections. When a leased line fails, the frame-relay traffic will be automatically routed over the ISDN to the DTE. The remote DTE must be aware of the backup because it must participate in establishing the ISDN connection. Therefore, the remote DTE must be a 3746 Model 900 or have equivalent backup capability.

Figure 16-6 on page 16-23 shows a failed frame-relay connection and the backup connection routed through a backup ISDN line.

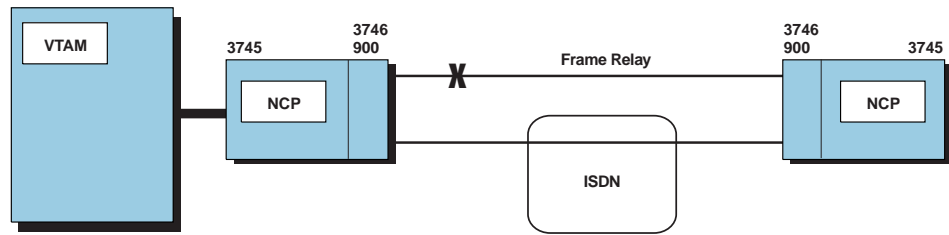

Figure 16-6. Frame-Relay Backup over an ISDN

**Defining the Backup Information:** To back up a frame-relay physical line over an ISDN B-channel, you specify that the line is eligible for backup and identify the backup ISDN resource in the frame-relay line's NCP definition statement. The 3746 Model 900 CSS automatically performs the necessary routing to, and station management for, the backup ISDN line. You do not have to recode the frame-relay resources specifications on the ISDN definition.

You can code the following definition statement and keywords to define the backup ISDN line for the frame-relay physical line on the frame-relay physical LINE definition statement.

LINE	ISDNCALL
	ISDNLPN
	ISDNLSA
	ISDNRPN
	ISDNRSA

ISDNCALL on the LINE definition statement specifies the port address of the backup ISDN physical line for the frame-relay physical line and whether the local or remote connection initiates backup if the frame-relay line fails. The port address is defined by the PORTADD keyword on the ISDN physical LINE definition statement. You can specify one or two backup ISDN physical lines for each frame-relay line eligible for backup. The second line is chosen when the first one is not active, or it is not available, or all its B-channels are in use.

The other keywords specify the connection information for the ISDN physical line that will back up the frame-relay physical line:

### Keyword Information Specified for the Backup ISDN Physical Line

**ISDNLPN** ISDN local party number

**ISDNLSA** ISDN local subaddress

**ISDNRPN** ISDN remote party number

**ISDNRSA** ISDN remote subaddress

See Chapter 7, "Integrated Services Digital Network (ISDN) Resources" on page 7-1 for information about defining ISDN resources.

### How Backup Operates

One end of the frame-relay line is configured as the backup initiator through the ISDNCALL operand. When it detects either a local hardware failure or an LMI failure, it automatically triggers the backup function by placing an ISDN call over the ISDN line(s) specified on the ISDNCALL operand.

### Controlling a Backup Call

When an ISDN call arrives, the called (remote) subaddress or the called (remote) party number is used to establish a call-on-demand or a backup call. The specific criteria follow:

1. If a called (remote) subaddress is present in the incoming call setup:
  - a. If it is identical to the ISDNLSA (local subaddress) keyword coded on the ISDN physical line, the call is accepted (call-on-demand).
  - b. If the subaddresses are not identical, each frame-relay line that is eligible for backup over this ISDN line is checked.
    - 1) If the called (remote) subaddress is identical to the ISDNLSA (local subaddress) keyword coded for the frame-relay line being checked, the call is accepted. Otherwise the next frame-relay line is checked.
    - 2) If the called (remote) subaddress in the incoming call setup does not match any of the frame-relay lines eligible for backup, the call is rejected.
2. If the called (remote) subaddress is not present in the incoming call setup:
  - a. If the called (remote) party number received in the incoming call setup is identical to the local party number specified with the ISDNLPN keyword, the call is accepted (call-on-demand).
  - b. If the party numbers are not identical, each frame-relay line that is eligible for backup over this ISDN line is checked.
    - 1) If the called (remote) party number is identical to the ISDNLPN (local party number) keyword coded for the frame-relay line being checked, the call is accepted. Otherwise, the next frame-relay line is checked.
    - 2) If the called (remote) party number in the incoming call setup does not match any of the frame-relay lines eligible for backup, the call is rejected.

In summary, the 3746 Model 900 uses two methods to detect whether an incoming ISDN call is for backup and to identify the line to be backed up:

- Subaddress method
- Number method

Checking subaddresses is the preferred method, whenever possible, because ISDN networks always transparently carry the subaddress. On the other hand, ISDN networks can change the format of the ISDN number, for example, from a national to an international number. Also some networks (for example, the French Numeris VN4 network) can truncate the called party number to keep only the part it needs. If you intend to use the number based method, ask your service provider how the network delivers the called party number.

The subaddress method can also help avoid unexpected backup attempts if used as a kind of password.



### How to Choose the Backup Method

Choose the subaddress method whenever the following criteria are met:

- The remote DTE is able to:
  - Issue or receive an ISDN call containing respectively the called or calling subaddress
  - Use the subaddress to identify the frame-relay line eligible for backup.
- The ISDN network provides the subaddress supplementary service.

Choose the number method whenever the following criteria are met:

- The remote DTE is able to use the ISDN number to identify the frame relay line eligible for backup.
- The ISDN network provides either the Direct Dialing Inward (DDI) or Multiple Subscriber Number (MSN) supplementary service.

### How to Subscribe the ISDN Line to the Network

- If you choose the subaddress method, you must subscribe to the subaddress supplementary service.
- If you choose the number method, you must subscribe to either the Direct Dialing Inward (DDI) or Multiple Subscriber Number (MSN) supplementary service. In addition, assign as many ISDN numbers as there are frame-relay lines eligible for backup.
- Whatever method you choose, subscribe to the Calling Line Identification Presentation (CLIP) supplementary service, which provides the called party with the calling party's ISDN number and subaddress information.
- Whatever method you choose, **do not** subscribe to the Calling Line Identification Restriction (CLIR) supplementary service, which prevents the called party from receiving the calling party's ISDN number and subaddress information.

### How to Code the Backup Keywords

- If you choose the subaddress method, allocate a different subaddress to each frame-relay line that is eligible for backup. When using this method, code ISDNRSA if you coded ISDNCALL=OUT; code ISDNLSA if you coded ISDNCALL=IN.
- If you choose the ISDN number method, you must allocate a different ISDN number to each frame-relay line that is eligible for backup. Therefore, you must be assigned as many ISDN numbers as the number of frame-relay lines that are eligible for backup. When using this method, code ISDNRPN if you coded ISDNCALL=OUT; code ISDNLPN if ISDNCALL=IN.
- Whichever method you choose, code ISDNRPN if ISDNCALL=OUT. This keyword is needed to place an ISDN outgoing call.
- You must code ISDNLSA, ISDNRSA, ISDNRPN, and ISDNLPN values that are compatible with the those at the remote end. For example, the local ISDNLSA value must equal the remote ISDNRSA value. Similarly, the local ISDNLPN value must equal the remote ISDNRPN value.

**Attention:** The ISDN network might change the called party number. In that case, the local ISDNLPN value would need to equal the value of the called party number received in the call setup (not the value of the remote ISDNRPN).

## Defining Frame-Relay Physical Lines

- Avoid coding ISDNRSA on the frame-relay line when ISDNCALL=OUT, while ISDNLSA is not coded on the remote end of the same frame-relay line. Otherwise the backup call will be rejected.

### How to Specify Backup between Two NCPs with 3746 Model 900s

The following examples show how to specify the backup keywords for the two ends of the same frame-relay leased line, where both DTEs are NCPs with 3746 Model 900s.

#### Subaddress Method

Backup Initiator	Backup Recipient
ISDNCALL=(p,q,OUT) ISDNRSA=A002 ISDNRPN=913031	ISDNCALL=(r,s,IN) ISDNLSA=A002

**Note:** The *q* and *s* suboperands are optional.

#### Number Method

Backup Initiator	Backup Recipient
ISDNCALL=(p,q,OUT) ISDNRPN=913031	ISDNCALL=(r,s,IN) ISDNLPN=913031

**Note:** The *q* and *s* suboperands are optional.

### Sample Definition of a Frame-Relay Line with ISDN Backup

Figure 16-7 on page 16-27 shows how to define a frame-relay physical line at address 2260 and port address 5 with an ISDN backup line. The ISDN line has a port address of 9, and the local party will initiate the backup. The ISDN line's local subaddress is A800. The ISDN line's remote party number is 9139313932, and its remote party subaddress is A809.

```

*****
*          FRAME RELAY PHYSICAL DEFINITIONS          *
*****
FRGRP   GROUP  FRELAY=(PHYSICAL,ANY),                *
          TYPE=NCP,                                  *
          DIAL=NO,                                    *
          LNCTL=SDLC,                                 *
          PUTYPE=1                                     *
FRLINE  LINE  ADDRESS=(2260,FULL),SPEED=38400,PORTADD=5, *
          ISDNRPN=9139313932,                         *
          ISDNRSA=A809,                                 *
          ISDNCALL=(9,OUT)                             *
FRLMI   PU    LMI=ANSI,                               *
          PUDR=NO,                                     *
          INNPORT=YES,                                 *
          ANS=CONTINUE                                 *
*
*****
*          ISDN PHYSICAL DEFINITIONS                  *
*****
PHYSG   GROUP  DIAL=NO,ISDN=PHYSICAL
PHYSL   LINE  ADDRESS=2176,PORTADD=9,ISDNLSA=A800
PHYSPU  PU    PUTYPE=1
*

```

Figure 16-7. Example: Defining a Frame-Relay Line with ISDN Backup

## Defining Frame-Relay Logical Subarea Lines

This section describes how to define frame-relay logical subarea lines. For more information on defining a frame-relay physical line to support a logical subarea link, see “Defining Frame-Relay Physical Lines” on page 16-8. For more information on defining subarea links in general, see “Defining SDLC Subarea Links” on page 12-3 and “Transmission Groups” on page 12-15.

A frame-relay logical subarea line is a PVC between TESP<sub>s</sub> in two NCP<sub>s</sub>. The two TESP<sub>s</sub> may be directly attached, or there may be one or more frame handlers between the two TESP<sub>s</sub>. A frame-relay subarea link can be part of a multilink transmission group (MLTG), along with SDLC and Token-Ring subarea links.

**Simple Frame-Relay Subarea Links:** Figure 16-8 on page 16-28 shows a sample network that uses the NCP frame handler and terminating equipment functions to provide the following subarea links among three NCP<sub>s</sub>:

- A subarea link between NCP1 and NCP2
- A subarea link between NCP2 and NCP3
- A subarea link between NCP1 and NCP3 through the frame handler function in NCP2.

## Defining Frame-Relay Logical Subarea Lines

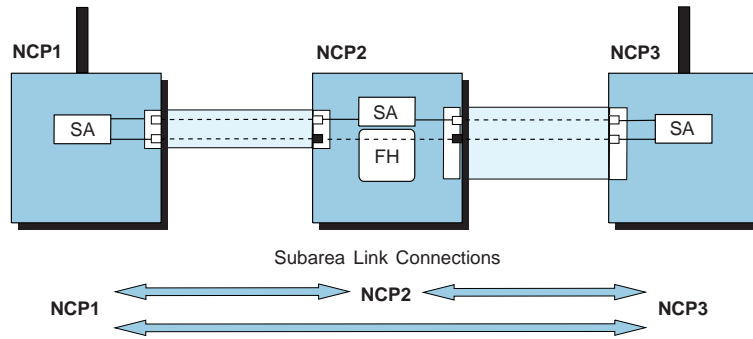

Figure 16-8. Frame-Relay Subarea Links

In the figure, the subarea link between NCP1 and NCP3 passes through the frame handler function in NCP2. This illustrates an important advantage of frame-relay subarea links over SNA subarea links: you can define a direct subarea link between non-adjacent NCPs. To link NCP1 and NCP3 using an SDLC link, you would need to do one of the following:

- Define an explicit subarea link between NCP1 and NCP3. This would require an additional physical line between NCP1 and NCP3.
- Route traffic over two separate subarea links, one between NCP1 and NCP2, and another between NCP2 and NCP3. This would require additional subarea path control processing.

The frame-relay configuration illustrated here eliminates the need for either of these additional resources. For a description of how to convert existing SDLC subarea links to frame relay, see “Converting SDLC Subarea Links to Frame Relay” on page 16-38.

**Frame-Relay Subarea Links in MLTGs:** Figure 16-9 shows a more complex configuration, in which the NCP frame-relay functions provide multiple physical paths in the same transmission group, thereby enhancing the reliability of the communication between two NCPs.

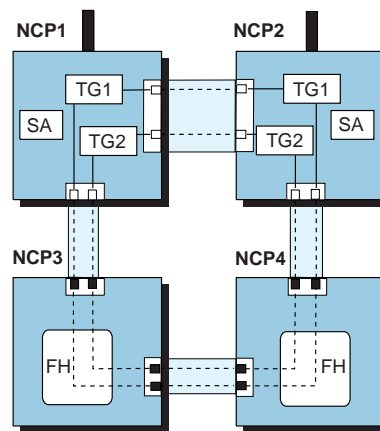

Figure 16-9. Frame-Relay Subarea Links in MLTGs

In the figure, NCP1 and NCP2 are linked by two MLTGs, TG1 and TG2. Each of these MLTGs contains two frame-relay subarea links, one directly between NCP1

and NCP2, and the other through the frame handler function in NCP3 and NCP4. In this configuration, both transmission groups can provide communication between NCP1 and NCP2 even if the direct link between NCP1 and NCP2 fails. This general approach of using frame relay to provide multiple physical paths in the same transmission group can enhance the reliability of subarea links in configurations with several NCPs.

**Boundary Access Node (BAN) for Frame-Relay Subarea Links:** Starting with V7R5, NCP supports frame-relay network 3746 Model 900 line connections to remote Token-Ring capable type 4 physical units (PU4s) through a remote BAN router, such as an IBM 6611 or IBM 2210.

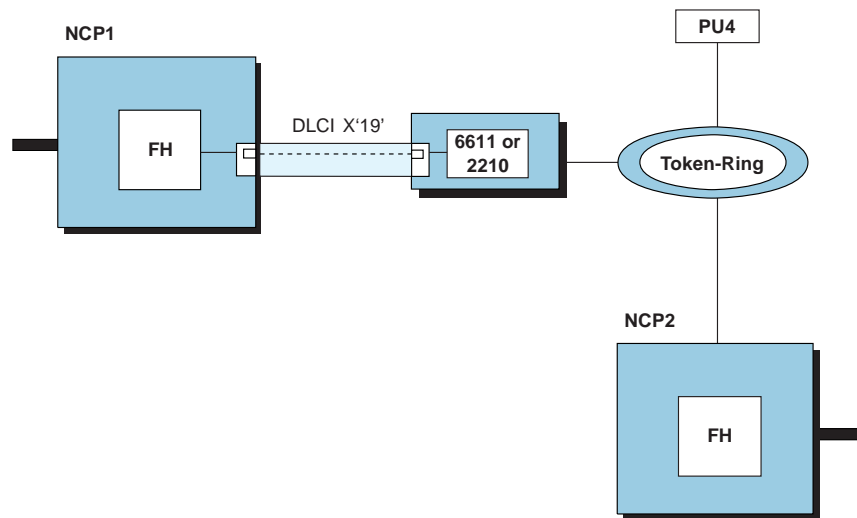

Figure 16-10. BAN for Subarea Links

In the figure, NCP1 is connected to a PU4 through a remote BAN router. This support does not provide DLCI multiplexing capability because subarea connections require unique DLCIs. The NCP frame-relay interface and the Token-Ring interface each have a MAC address. The MAC addresses are used in addition to the DLCI to identify the BAN device on a frame-relay physical port. You must define the MAC address on both ends of the subarea connection.

You should not use BAN for frame-relay subarea link support with a logical link control (LLC) termination (BAN-2) connection in a mixed-media MLTG environment because the TG can hang if a frame is lost. When you connect the frame-relay subarea link, you might need to change the values of the T1TIMER, T2TIMER, and RETRIES keywords for the Token Ring logical LINE definition statement to take into account slower frame-relay line speeds. For more information about these keywords, see “Defining Token-Ring Logical Connections” on page 6-20.

For a sample definition of a frame-relay BAN subarea link, see “Sample Definition of a Frame-Relay BAN Subarea Link” on page 16-43.

Code the following definition statements and keywords to define a frame-relay logical subarea line and the associated TESP.

## Defining Frame-Relay Logical Subarea Lines

SDLCST	GROUP MODE RETRIES
PATH	ER $n$
GROUP	MODE
GROUP	FRELAY PHYSRSC
LINE	IPL LOCALTO MLTGPRI MONLINK NPACOLL RETRIES SDLCST T1TIMER <sup>1</sup> T2TIMER
PU	ADDR (DLCIs 16-254) DLCI <sup>1</sup> (DLCIs 16-991) BLOCK COMRATE <sup>2</sup> DYNWIND <sup>3</sup> MAXDATA MAXOUT NETID PIUCHECK <sup>4</sup> TGN

<sup>1</sup> Supported starting with NCP V7R3. DLCI is valid only for VTAM V4R3 or later releases.

<sup>2</sup> Supported starting with NCP V7R2.

<sup>3</sup> Supported starting with NCP V7R3.

<sup>4</sup> Supported starting with NCP V7R7.

### SDLCST

GROUP on the SDLCST definition statement identifies the stand-alone GROUP definition statement that defines the characteristics of the subarea link. See the discussion of the stand-alone GROUP definition statement for more information.

MODE specifies whether the subarea link characteristics defined by this SDLCST definition statement are to be used when NCP is in a primary or secondary state.

RETRIES specifies how many attempts NCP is to make to recover from errors occurring during transmission over the subarea link.

You might need to code the values of RETRIES on the SDLCST definition statement and T1TIMER on the LINE definition statement such that the combination of these two values is greater than the LMI error thresholds (ERRORT

and TIMERS on the PU definition statement) of the adjacent NCP. This way, the frame-relay network can detect an error on the PVC before NCP detects an error on the SNA link, which enables the frame-relay network to switch to the backup route before the subarea link is deactivated.

### PATH

ER $n$  on the PATH definition statement defines various characteristics of an explicit route between two subareas. The first suboperand identifies the adjacent subarea along the explicit route. When you are defining a frame-relay subarea link that passes through one or more frame handlers (as between NCP1 and NCP3 in Figure 16-8 on page 16-28), the subarea of an NCP functioning as a frame handler is *not* considered an adjacent subarea. (For example, in Figure 16-8, NCP1 and NCP3 are in adjacent subareas.) Consequently, for the first suboperand of ER $n$ , specify the nearest subarea that does *not* contain an NCP functioning as a frame handler. For more information on the ER $n$  keyword, see page 11-4.

For frame-relay logical subarea links, you need to code two types of GROUP definition statements:

1. Code one or more stand-alone GROUP definition statements to define characteristics of the link when NCP is in primary or secondary mode. See “Stand-Alone GROUP Definition Statements” on page 1-15 for more information.
2. Code one or more GROUP definition statements to define groups of logical lines.

### GROUP

MODE specifies whether the link characteristics defined by this stand-alone GROUP definition statement are to be used when NCP is in a primary or secondary state.

### GROUP

FRELAY on the GROUP definition statement for logical lines specifies that it is a group of frame-relay logical lines. Code FRELAY=LOGICAL or FRELAY=(LOGICAL,SUBAREA) to define a group of frame-relay logical subarea lines.

PHYSRSC associates a group of logical lines with a specific physical line. Specify the name of the PU definition statement for the link station on the physical line.

### LINE

IPL specifies whether an NCP can be loaded or dumped over this link. Code IPL=YES to load a remote NCP over a frame-relay subarea link. See “Remote Loading and Activation over a Frame-Relay Line” on page 16-73 for more information.

MLTGPRI assigns a priority to each line in an MLTG. Code MLTGPRI only when you define a frame-relay line in an MLTG.

MONLINK specifies whether NCP is to include the SSCP monitor mode function (SMMF) for type 4 physical units attached to subarea links. If you code MONLINK=YES for a frame-relay subarea link, also code XMONLNK=YES on the PU definition statement for the physical line. If you code MONLINK only, the link activation will fail.

NPACOLL specifies whether the link is to be eligible for NPM performance data collection. Frame-relay logical lines use extended format COLLECT request/response units.

## Defining Frame-Relay Logical Subarea Lines

RETRIES specifies how many attempts NCP is to make to recover from errors that occur during transmission over a link.

SDLCST identifies the names of SDLCST definition statements that define the values used for MAXOUT and RETRIES when NCP is in a primary or a secondary state. See "Defining Configurable Point-to-Point Subarea Links" on page 12-8 for more information about how to define NCP to operate in a primary or a secondary state.

LOCALTO and, starting with NCP V7R3, T1TIMER specify the T1 (reply) timer interval for a local link. It is important to code a value for T1TIMER or LOCALTO that reflects the maximum amount of time that it takes to receive a solicited response from the adjacent link station. Factors that can affect this time include line speed, propagation delay, maximum frame size, delay caused by intermediate frame handlers, and the number of DLCIs supported by the associated physical line that could create queuing delays for the FRTEs. If the value you code for T1TIMER or LOCALTO is too small, the FRTEs can lose synchronization and fail the connection. This is indicated by an INOP 01 and a link event or an alert that indicates a frame reject (FRMR) condition. If this occurs, code a larger T1TIMER or LOCALTO value for this FRTE connection. See "Determining a T1 (Reply) Timer Value for a Local Link" on page 16-36 for more information about determining a value.

T2TIMER specifies the acknowledgment (T2) timer interval and I-frame count for this resource. NCP sends an acknowledgment when the T2 timer interval expires or when the number of I-frames received reaches the I-frame count, whichever occurs first. For more information, see "Acknowledgment Timer" on page 6-45.

### PU

Code one PU definition statement to define the TESP for the subarea link.

ADDR on the PU definition statement defines the data link connection identifier of the TESP. To specify addressing greater than X'FE', use the DLCI keyword.

If the link-station support on the physical line does not support the LMI protocol, you can use DLCIs X'10'–X'FE'. For boundary access node (BAN) for frame-relay subarea links, ADDR on the PU definition statement identifies the destination service access point (DSAP) and the medium access control (MAC) address to the session partner. The DLCI keyword is required to specify the DLCI for the connection.

BLOCK on the PU definition statement specifies the maximum frame size and the maximum number of PIUs per frame. The value of BLOCK must not exceed the value of MAXFRAME for the physical line. See page 24-7 for more information on the BLOCK keyword.

COMRATE on the PU definition statement specifies whether certain frames sent on this resource can be discarded by the frame-relay network to ease network congestion. Frames in a frame-relay network can be designated as discard eligible. COMRATE also specifies the relative priority among frame-relay stations (For example, FRTEs, FHSPs, and IPSPs) associated with a frame-relay port.

Frames in a frame-relay network can be designated as *discard eligible*. When the network is congested, discard eligible frames can be discarded to expedite the processing of other frames. Code COMRATE=FULL to specify that no frames are



to be designated as discard eligible. Code COMRATE=NONE to cause NCP to designate all but the following frame types as discard eligible:

- S-frames (RR, RNR, and REJ), including RRs piggybacked on I-frames
- Network priority frames (VR pacing and TG sweep)
- XIDs.

To ensure equitable treatment of all traffic in the frame-relay network, choose a value for COMRATE such that NCP is consistent with the rest of the network in the use of discard eligible frames. It is recommended that you code COMRATE=NONE for connections to frame-relay networks containing only nodes with NCP V6R2 or later.

### **3745 Frame Relay (NCP V7R5 or Earlier) and 3746 Model 900 Frame Relay:**

The *priority* suboperand, coded as COMRATE=(FULL,*priority*) or COMRATE=(NONE,*priority*), specifies the relative priority of an FRTE station as compared to all other associated physical stations and associated FRTE stations. The value of the *priority* suboperand of COMRATE is multiplied by the value of DATBLK on the LINE definition statement for the physical line to determine the guaranteed minimum number of bytes that a resource can transmit before a different resource must be given a transmit opportunity. (See page 16-11 for more information about the DATBLK keyword.)

The relative priority of an FRTE station can be determined as a fraction of the total available transmission time on a line that the station gets. This fraction is calculated by dividing the station's COMRATE *priority* value by the sum of the COMRATE *priority* values for all stations on the line:

$$\frac{\text{PU1's } \textit{priority} \text{ value}}{\text{Sum of } \textit{priority} \text{ values of all PUs on or associated with the physical line}}$$

For example, if there are three PUs for a line, PU1's transmission fraction is determined like this:

$$\frac{\text{PRIORITY}_{\text{PU1}}}{\text{PRIORITY}_{\text{PU1}} + \text{PRIORITY}_{\text{PU2}} + \text{PRIORITY}_{\text{PU3}}}$$

Where PRIORITY = the value of the respective PU's *priority* suboperand of the COMRATE keyword.

**3745 Frame Relay (NCP V7R6 and later releases):** The *priority* suboperand, coded as COMRATE=(FULL,*priority*) or COMRATE=(NONE,*priority*), specifies the relative priority of an FRTE station as compared to all other FRTE stations associated with the same physical line. The value of the *priority* suboperand of COMRATE is multiplied by the value of DATBLK on the LINE definition statement for the physical line to determine the guaranteed minimum number of bytes that a resource can transmit before a different resource must be given a transmit opportunity. (See page 16-11 for more information about the DATBLK keyword.)

The relative priority of an FRTE station can be determined as a fraction of the total available bandwidth afforded the SNA protocol that the station receives. This fraction is calculated by dividing the FRTE station's

## Defining Frame-Relay Logical Subarea Lines

COMRATE *priority* value by the sum of the COMRATE *priority* values for all FRTE stations associated with the line:

$$\frac{\text{FRTE PU1's } \textit{priority} \text{ value}}{\text{Sum of } \textit{priority} \text{ values of all FRTE PUs associated with the physical line}}$$

For example, if three FRTE PUs are associated with a physical line, PU1's transmission fraction of the SNA protocol's total bandwidth is determined like this:

$$\frac{\text{PRIORITY}_{\text{PU1}}}{\text{PRIORITY}_{\text{PU1}} + \text{PRIORITY}_{\text{PU2}} + \text{PRIORITY}_{\text{PU3}}}$$

Where PRIORITY = the value of the respective PU's *priority* suboperand of the COMRATE keyword.

In addition to using the COMRATE keyword to specify *priority* values for FRTE stations, you can use the FRRATES keyword to specify a *priority* value for the SNA protocol. See page FRRATES on the LINE Definition Statement on page 16-11.

DLCI on the PU definition statement defines the data link connection identifier of the TESP. You can also specify the DLCI using the ADDR keyword. If the link-station subport on the physical line does not support LMI protocol, you can use DLCIs X'10'-X'3DF' (16-991 in decimal).

If the link-station subport supports LMI protocol, the maximum DLCI is the smaller of:

- The largest DLCI allowed by the line adapter for this line, as described previously
- The value of the following expression (converted to hexadecimal):

$$((\textit{maxframe} - \textit{fixed}) \div 5) + 15$$

where:

*maxframe* is the value of MAXFRAME for this line.

*fixed* is 17 when LMI=CCITT or LMI=CCITT-NUI.

*fixed* is 18 when LMI=ANSI or LMI=ANSI-NUI.

The DLCI of a link-station subport that uses the LMI protocol represents the largest number of DLCI status entries that can be transmitted in a single LMI status message frame. The value  $(\textit{maxframe} - \textit{fixed}) \div 5$  is the maximum number of subports of all types that can be active on the line at the same time.

### Notes:

1. For releases prior to NCP V7R3: If you specify a value greater than 4894 for MAXFRAME on the LINE definition statement, or if you do not code MAXFRAME, you can assign any valid DLCI value (depending on the line type) to a TESP.
2. Be sure to assign the same DLCI to the subports at each end of a PVC segment.

3. A peripheral link cannot use a DLCI that is defined to NCP for a subarea link TESP or an FHSP. Incoming calls from frame-relay-attached peripheral devices often use DLCI X'20' (32 in decimal). Therefore, if your NCP includes frame-relay peripheral links, you should avoid using DLCI X'20' for a subarea link TESP or an FHSP on the same physical line. Otherwise, all the peripheral devices on the physical line must be reconfigured to use a different DLCI.

DYNWIND on the PU definition statement defines the dynamic characteristics of the frame transmission window for the logical subarea physical unit. This window is the number of frames NCP can send before waiting for an acknowledgment. The maximum window size for each logical connection is defined by MAXOUT on the PU definition statement.

DYNWIND defines the following values:

*nw*

The rate at which the window size increases after it has been decreased by frame loss or congestion. This is the IEEE 802.2 LLC *Nw* parameter. After NCP has decreased the transmission window size, NCP increases the window size after *Nw* frames transmitted by NCP are received and acknowledged by the adjacent device. This process continues until the window size reaches its maximum.

*dw, dwc, and mww*

The rates at which the window size decreases when frame loss or congestion occurs, and the minimum size for the transmission window. The defaults for these values cause NCP to decrease the window size to 1 immediately, in conformance with the IEEE 802.2 logical link control (LLC) protocol. You can increase the transmission rate by coding values that cause the window size to decrease more slowly or by coding a value that limits the reduction of the window size. See the description of the DYNWIND keyword on the PU statement in *NCP, SSP, and EP Resource Definition Reference* for a list of valid *dw, dwc, and mww* values and their effects on the working window.

*dwdmax*

The upper limit for the time delay that NCP initiates before transmitting the next I-frame for a 3745 FRTE station experiencing congestion. NCP initiates the time delay if congestion continues while a station's working transmit window is equal to 1. When an FRTE station's DLCI is assigned a low committed information rate (CIR) on a high speed link, the dynamic window algorithm might not prevent the station from experiencing congestion even with a working transmit window of 1. When congestion is detected in this case, NCP introduces an initial 100 millisecond (ms) delay between I-frame transmissions. NCP increases the time delay by 100 ms increments to the upper limit (*dwdmax*) while congestion occurs. Conversely, when congestion clears, NCP decreases the time delay by 100 ms decrements.

*twcuse*

Whether or not NCP ignores any subsequent BECN for the window congestion time of 100 ms after receiving the initial BECN. The *twcuse* suboperand is intended to prevent NCP 3745 FRTE stations from overreacting to mild congestion. It applies only when the working transmit window is greater than 1.

## Defining Frame-Relay Logical Subarea Lines

MAXDATA on the PU definition statement minimizes the coordination problems among different line types by limiting the maximum amount of data the link station sends or receives in one data transfer. The limit you specify includes one PIU or PIU segment and header information. Code MAXDATA for a frame-relay line in an MLTG. See “MLTG Segment Size” on page 12-23 for more information about how to determine the correct segment size for a frame-relay line.

MAXOUT specifies how many frames NCP is to send over the subarea link before waiting for a response.

NETID on the PU definition statement specifies the name of the network containing the adjacent subarea node.

PIUCHECK specifies whether a checksum validation should be performed on PIUs sent and received by this station. For the checksum validation support to be enabled, the adjacent link station must also have PIUCHECK=YES coded. For more information about the PIUCHECK subarea checksum support, see PIUCHECK keyword on the PU definition statement on page 24-9.

T2TIMER specifies the acknowledgment (T2) timer interval and I-frame count for this resource. NCP sends an acknowledgment when the T2 timer interval expires or when the number of I-frames received reaches the I-frame count, whichever occurs first. For more information, see “Acknowledgment Timer” on page 6-45.

Code one PU definition statement to define the TESP for the subarea link.

TGN assigns the logical link to a specific transmission group. For more information, see “Transmission Groups” on page 12-15.

## Determining a T1 (Reply) Timer Value for a Local Link

The T1 (reply) timer value can be specified with the LOCALTO keyword or, starting with NCP V7R3, the *localt1* suboperand of the T1TIMER keyword. Figure 16-11 shows a portion of a network used as an example here to illustrate how to code the T1 (reply) timer value. In this example, the line speed is 19.2 Kbps for each of the two hops in the link between Node A and Node C, the average frame size is 256 bytes, and the average queue size is 4 frames.

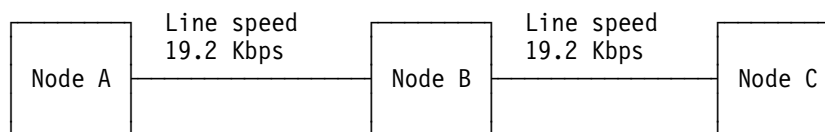

Figure 16-11. Sample to illustrate how to code the T1 (reply) timer value

To determine a T1 (reply) timer value to code a link between Node A and Node C:

1. Calculate the transmission time for each hop.
2. Calculate the total transmission time from Node A to Node C and back.
3. Calculate the total queue time.
4. Add the total transmission time to the total queue time.
5. Consider additional possible delays because of heavy traffic.

The following sections show the details of these steps for the example in Figure 16-11.

**Calculate the transmission time for each hop:** The transmission time for each hop in the example shown in Figure 16-11 is calculated as follows:

$$\frac{256 \text{ bytes/frame} \times 8 \text{ bits/byte}}{19200 \text{ bits/second}} = \frac{256 \times 8}{19200} = 0.1 \text{ second/frame}$$

The transmission time for each hop is 0.1 second per frame.

**Calculate the total transmission time:** To transmit a frame from Node A to Node C and for Node A to receive an acknowledgment, it takes four hops:

$$4 \text{ hops} \times 0.1 \text{ seconds/hop} = 0.4 \text{ second}$$

The total transmission time to send a frame from Node A to Node C and for Node A to receive an acknowledgment is 0.4 second.

**Calculate the amount of queue time:** First, the average size of a queue is four frames. Therefore, on average, four other transmissions occur before the frame gets transmitted. This means that at each queue, the average queue time is:

$$4 \text{ frames/queue} \times 0.1 \text{ second/frame} = 0.4 \text{ second/queue}$$

The frame and the acknowledgment can end up on a total of four queues (twice at Node B, once at Node C, and once at Node A). Therefore, the total possible time on the queue for a frame to get from Node A to Node C and for the acknowledgment to be received back at Node A is:

$$0.4 \text{ second/queue} \times 4 \text{ queues} = 1.6 \text{ seconds}$$

**Add the total transmission time to the total queue time:** The total time to send a frame from Node A to Node C and to receive an acknowledgment, including queue time, is the sum of the total transmission time plus the total queue time:

$$0.4 \text{ seconds} + 1.6 \text{ seconds} = 2.0 \text{ seconds}$$

**Consider additional possible delays because of heavy traffic:** To handle the extra time that might be required for heavy traffic and to avoid unneeded retries, use two to three times the value calculated so far:

$$2 \text{ seconds} \times 2 = 4 \text{ seconds}$$

$$2 \text{ seconds} \times 3 = 6 \text{ seconds}$$

Therefore, a good T1 (reply) timer value to use for the link between Node A and Node C in this example is 4-6 seconds.

## NDF-Added Keywords for Frame-Relay Logical Subarea Lines

When you define frame-relay logical subarea lines, NDF adds the following keywords to your generation definition if you do not code them.

## Defining Frame-Relay Logical Subarea Lines

GROUP	COMPOWN=YES,	3745 frame relay only
	COMPSWP=NO,	3745 frame relay only
	DIAL=NO,	
	LEVEL2=ECLNAVL2,	3745 frame relay only
	LEVEL3=ECLNAVL3,	3745 frame relay only
	LEVEL5=NCP,	3745 frame relay only
	LINEADD=NONE,	3745 frame relay only
	LNCTL=SDLC,	
	NPACOLL=(YES,EXTENDED),	1
	PUTYPE=4,	
	RETRIES=(6,0,0),	
	TYPE=NCP,	
	XIO=(ECLNAVXL,ECLNAVXS,ECLNAVXI,ECLNAVXX)	3745 only
LINE	UACB=X\$LnB	2 3745 frame relay only
PU	NPACOLL=NO	1 3745 frame relay only
GENEND	INIT=ECLINIT,	3745 frame relay only
	TMRTICK=ECLTICK,	3745 frame relay only
	UGLOBAL=ECLUGBL	3745 frame relay only

1 Added if NPA=YES on the BUILD definition statement.  
2 n is a counter that is incremented for each logical line.

Figure 16-12. NDF-Added Keywords for Frame-Relay Logical Subarea Lines

## Converting SDLC Subarea Links to Frame Relay

As described in the introduction to this chapter and in “Defining Frame-Relay Logical Subarea Lines” on page 16-27, frame-relay subarea links can offer significant advantages over SDLC subarea links. This section describes how to convert an SDLC subarea link to frame relay and shows a sample conversion.

Figure 16-13 on page 16-39 shows portions of the generation definitions for two NCPs, NCP1 and NCP2. These portions define two SDLC subarea links between NCP1 and NCP2. The steps following Figure 16-13 on page 16-39 describe how to convert SDLC subarea links to frame relay. Figure 16-14 on page 16-41 shows the result of performing these steps on the generation definitions in Figure 16-13 on page 16-39. In this example, only one of the two SDLC subarea links is converted to frame relay.

This example shows only the main keywords involved in the process of converting from SDLC to frame relay. There are many other keywords you can code when defining frame-relay resources. For more information, see “Defining Frame-Relay Logical Subarea Lines” on page 16-27.

```

*****
*                               NCP1 - SUBAREA LINKS TO NCP2                               *
*****
APRI    SDLCST  GROUP=A,MODE=PRI
ASEC    SDLCST  GROUP=B,MODE=SEC
A       GROUP   MODE=PRI
B       GROUP   MODE=SEC
*
SDLCGRP GROUP                                SDLC group
*
SDLC64L LINE   ADDRESS=(064,FULL),
           SDLCST=(APRI,ASEC)
SDLC64P PU     PUTYPE=4,
           TGN=1
*
SDLC68L LINE   ADDRESS=(068,FULL),
           SDLCST=(APRI,ASEC)
SDLC68P PU     PUTYPE=4,
           TGN=1

```

Figure 16-13 (Part 1 of 2). Example: Converting an SDLC Subarea Link to Frame Relay (Before)

```

*****
*                               NCP2 - SUBAREA LINKS TO NCP1                               *
*****
APRI    SDLCST  GROUP=A,MODE=PRI
ASEC    SDLCST  GROUP=B,MODE=SEC
A       GROUP   MODE=PRI
B       GROUP   MODE=SEC
*
SDLCGRP GROUP                                SDLC group
*
SDLC48L LINE   ADDRESS=(048,FULL),
           SDLCST=(APRI,ASEC)
SDLC48P PU     PUTYPE=4,
           TGN=1
*
SDLC52L LINE   ADDRESS=(052,FULL),
           SDLCST=(APRI,ASEC)
SDLC52P PU     PUTYPE=4,
           TGN=1

```

Figure 16-13 (Part 2 of 2). Example: Converting an SDLC Subarea Link to Frame Relay (Before)

Follow these steps for *both* NCPs to convert an SDLC subarea link to frame relay. These steps are illustrated in Figure 16-14 on page 16-41.

- 1** Add a GROUP definition statement to define a group of frame-relay physical subarea lines.

Perform the remaining steps for *each* SDLC subarea link to be converted to frame relay. For example, to convert three subarea links, you would need to perform these steps three times for each NCP. (These steps are shown only once in Figure 16-14 on page 16-41 since only one subarea link is being converted.)

## Defining Frame-Relay Logical Subarea Lines

- 2** Under the GROUP definition statement for the physical line group, add a LINE definition statement to define a frame-relay physical line. For the ADDRESS keyword, use the line number specified by ADDRESS for the corresponding SDLC subarea link.
- 3** Under the LINE definition statement for the physical line, add a PU definition statement to define the link-station support. If you code the LMI keyword to include the echo detection function, be sure to specify PRI for one NCP and SEC for the other.
- 4** Add a GROUP definition statement to define a group of frame-relay logical subarea lines. The group will contain only one logical line.
- 5** Add the PHYSRSC keyword to the GROUP definition statement to associate the logical line in that group with the physical line. Specify the name of the PU definition statement that defines the link-station support (FRP64P in NCP1).
- 6** Under the GROUP definition statement for the logical line group:
  1. Move the LINE and PU definition statements for the SDLC subarea link to the frame-relay logical line group.
  2. Delete the ADDRESS keyword from the LINE definition statement.

The LINE definition statement now defines the frame-relay logical subarea line, and the PU definition statement now defines the TESP. Notice that when you convert an SDLC subarea link to frame relay, you do not need to change the transmission group to which the subarea link is assigned.
- 7** Add the DLCI keyword to the PU definition statement for the TESP to define the DLCI for the TESP (X'60' in this example).

Figure 16-14 on page 16-41 shows the result of performing these steps to convert one of the SDLC subarea links in the generation definitions in Figure 16-13 on page 16-39.



```

*****
*                               NCP1 - SUBAREA LINKS TO NCP2                               *
*****
APRI    SDLCST GROUP=A,MODE=PRI
ASEC    SDLCST GROUP=B,MODE=SEC
A        GROUP  MODE=PRI
B        GROUP  MODE=SEC
*
FRPGRP  GROUP  FRELAY=(PHYSICAL,SUBAREA)  FR physical group      1
FRP64L  LINE   ADDRESS=(064,FULL),        2
                                                DATABLK=4096
FRP64P  PU     LMI=ANSI                                3
*
FRLGRP  GROUP  FRELAY=(LOGICAL,SUBAREA),  FR logical group      4
                                                PHYSRSC=FRP64P          5
FRL1L   LINE   SDLCST=(APRI,ASEC)          6
FRL1P   PU     PUTYPE=4,
                                                TGN=1,
                                                DLCI=(60,H)            TESP DLCI X'60'      7
*
SDLCGRP GROUP                                     SDLC group
SDLC68L LINE   ADDRESS=(068,FULL),
                                                SDLCST=(APRI,ASEC)
SDLC68P PU     PUTYPE=4,
                                                TGN=1

```

Figure 16-14 (Part 1 of 2). Example: Converting an SDLC Subarea Link to Frame Relay (After)

```

*****
*                               NCP2 - SUBAREA LINKS TO NCP1                               *
*****
APRI    SDLCST GROUP=A,MODE=PRI
ASEC    SDLCST GROUP=B,MODE=SEC
A        GROUP  MODE=PRI
B        GROUP  MODE=SEC
*
FRPGRP  GROUP  FRELAY=(PHYSICAL,SUBAREA)  FR physical group      1
FRP48L  LINE   ADDRESS=(048,FULL),        2
                                                DATABLK=4096
FRP48P  PU     LMI=ANSI                                3
*
FRLGRP  GROUP  FRELAY=(LOGICAL,SUBAREA),  FR logical group      4
                                                PHYSRSC=FRP48P          5
FRL1L   LINE   SDLCST=(APRI,ASEC)          6
FRL1P   PU     PUTYPE=4,
                                                TGN=1,
                                                DLCI=(60,H)            TESP DLCI X'60'      7
*
SDLCGRP GROUP                                     SDLC group
SDLC52L LINE   ADDRESS=(052,FULL),
                                                SDLCST=(APRI,ASEC)
SDLC52P PU     PUTYPE=4,
                                                TGN=1

```

Figure 16-14 (Part 2 of 2). Example: Converting an SDLC Subarea Link to Frame Relay (After)

## Sample Definition of a Frame-Relay Subarea Link

Figure 16-15 illustrates a frame-relay subarea link between TESP's in two NCPs.

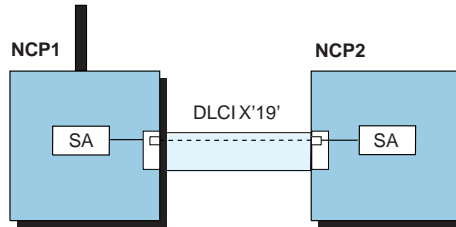

Figure 16-15. Frame-Relay Logical Subarea Line

Figure 16-16 shows how to define the subarea link for NCP1 shown in Figure 16-15.

DLCI=(19,H) on PU B75PL1A **5** defines X'19' as the DLCI used for the subarea connection to NCP2.

PHYSRSC=B75P48 **3** is coded on the logical group to associate logical line B75LL1A **4** and PU B75PL1A **5** with LMI PU B75P48 **2** under physical line B75F48 **1**.

```

S75PRI  SDLCST . . .
S75SEC  SDLCST . . .
.
.
.
*****
* FRAME RELAY PHYSICAL LINE GROUP                                     *
*****
B75FRGP1 GROUP FRELAY=PHYSICAL,                                     X
                ISTATUS=ACTIVE,      VTAM-only keyword           X
                TYPE=NCP,             Automatically added by NDF  X
                XMONLNK=YES

*
*****
* FRAME RELAY PHYSICAL LINE 48 - FULL DUPLEX 56KB                   *
*****
1 B75F48  LINE ADDRESS=(048,FULL),                                  *
                CLOCKNG=EXT,                                          *
                MAXFRAME=2106,                                        *
                NRZI=NO,       The default is NO                     *
                SPEED=56000,                                         *
                DATABLK=4096

2 B75P48  PU  ERRORR=(3,4),                                         *
                LMI=ANSI,                                           *
                SPOLL=6,                                             *
                TIMERS=(10,15)
                .
                .
                .

```

Figure 16-16. Example: Defining a Frame-Relay Subarea Link

```

*****
* FRAME RELAY LOGICAL LINE GROUP *
*****
B75FRGL1 GROUP FRELAY=LOGICAL,      Define frame-relay logical lines  X
                ISTATUS=ACTIVE,     VTAM-only keyword                 X
                MAXOUT=127,          X
3             PHYSRSC=B75P48,       Associate logical line with physical X
                RETRIES=(5,5,5),     X
                SDLCST=(S75PRI,S75SEC) Primary-secondary selection table
*                                     entry
*****
* LOGICAL LINE 1 --- DLCI X'19' TALKS TO DLCI X'19' IN NCP2 *
*****
4 B75LL1A LINE ISTATUS=ACTIVE,     VTAM-only keyword *
                MONLINK=YES,        Include SMMF for type 4 PUs *
                IPL=YES
*
5 B75PL1A PU  DLCI=(19,H),          FRTE support for DLCI X'19' *
                ANS=CONTINUE,       CONT is default for FRELAY=LOGICAL *
                PUTYPE=4,           PUTYPE=4 added to GROUP by NDF *
                TGN=1               Transmission group number is 1

```

Figure 16-16. Example: Defining a Frame-Relay Subarea Link

### Sample Definition of a Frame-Relay BAN Subarea Link

Figure 16-17 on page 16-44 shows how to define the subarea link for NCP1 shown in Figure 16-10 on page 16-29.

DLCI=(19,H) on PU B75PL1A **5** defines X'19' as the DLCI used for the subarea BAN connection to NCP2.

PHYSRSC=B75P48 **3** is coded on the logical group to associate logical line B75LL1A **4** and PU B75PL1A **5** with LMI PU B75P48 **2** under physical line B75F48 **1**.

ADDR **6** on the PU definition statement identifies the destination service access point (DSAP) and the medium access control (MAC) address of NCP2.

## Defining Frame-Relay Logical Subarea Lines

```

S75PRI  SDLCST . . .
S75SEC  SDLCST . . .
.
.
.
*****
* FRAME RELAY PHYSICAL LINE GROUP                                     *
*****
B75FRGP1 GROUP FRELAY=PHYSICAL,                                     X
                ISTATUS=ACTIVE,      VTAM-only keyword           X
                TYPE=NCP,            Automatically added by NDF   X
                XMONLNK=YES

*
*****
* FRAME RELAY PHYSICAL LINE 2248 - FULL DUPLEX 56KB                 *
*****
1 B75F48  LINE ADDRESS=(2248,FULL),                                *
                CLOCKNG=EXT,                                        *
                LOCADD=4FFF00000000,                               *
                MAXFRAME=2106,                                     *
                NRZI=NO,           The default is NO              *
                SPEED=56000,                                       *
                DATABLK=4096                                        *
2 B75P48  PU  ERROR=(3,4),                                        *
                LMI=ANSI,                                          *
                SPOLL=6,                                           *
                TIMERS=(10,15)                                     *
                .
                .
                .
*****
* FRAME RELAY LOGICAL LINE GROUP                                     *
*****
B75FRGL1 GROUP FRELAY=LOGICAL,      Define frame-relay logical lines X
                ISTATUS=ACTIVE,      VTAM-only keyword           X
                MAXOUT=127,                                                  X
3          PHYSRSC=B75P48,          Associate logical line with physical X
                RETRIES=(5,5,5),                                           X
                SDLCST=(S75PRI,S75SEC) Primary-secondary selection table
                entry
*
*****
* LOGICAL LINE 1 --- NCP1 USES DLCI X'19' TO TALK TO NCP 2 (MAC ADDRESS*
*          400000D62208, SAP 04)                                         *
*****
4 B75LL1A LINE ISTATUS=ACTIVE,      VTAM-only keyword           *
                MONLINK=YES,        Include SMMF for type 4 PUs      *
                IPL=YES

*
5 B75PL1A PU  DLCI=(19,H),          FRTE support for DLCI X'19'      *
6          ADDR=04400000D62208,                                           *
                ANS=CONTINUE,        CONT is default for FRELAY=LOGICAL *
                PUTYPE=4,            PUTYPE=4 added to GROUP by NDF   *
                TGN=1                Transmission group number is 1    *

```

Figure 16-17 (Part 1 of 2). Example: Defining a Frame-Relay BAN Subarea Link

---

## Defining Frame-Relay Logical Peripheral Lines

A frame-relay logical peripheral line is a PVC between a TESP in an NCP and a TESP in a peripheral device. The two TESP's can be directly attached, or there can be one or more frame handlers between the two TESP's.

NCP supports two types of frame-relay logical peripheral lines:

**Frame-Relay Boundary Network Node (BNN):** Frame-relay BNN is one method of connecting SNA peripheral devices to NCP. A peripheral device is identified on the physical port by the DLCI of its PVC and by its 802.2 LLC service access point (SAP) address. Note that multiple frame-relay BNN attached devices can share the same DLCI, as long as they each use a different SAP.

**Frame-Relay Boundary Access Node (BAN):** Frame-relay BAN is another method of connecting remote LAN-attached SNA peripheral devices to NCP over frame relay, using a remote BAN router (such as an IBM Nways 6611 Network Processor (IBM 6611) or IBM Nways 2210 Multiprotocol Router (IBM 2210)) to perform the LAN-to-frame-relay mapping. The only thing different about a BAN connection from a frame-relay BNN connection is that in the BAN configuration, the NCP frame-relay interface and each peripheral device has a MAC address, as if the peripheral devices were attached to one of NCP's Token Ring adapters. The MAC addresses are used in addition to the DLCI and SAPs to identify the BAN device on a frame-relay physical port. Thus, multiple frame-relay BAN-attached devices can share the same DLCI as long as they each use a different MAC+SAP combination.

Note that some remote BAN routers (such as the IBM 6611 and IBM 2210 routers) can support SDLC-attached SNA peripheral devices using BAN. To accomplish this, the remote BAN router must assign a unique MAC address and SAP to each SDLC-attached SNA peripheral device, for use on the frame-relay BAN connection to NCP. The remote BAN router might also have to perform other functions, such as translation of the frame-relay 802.2 LLC to SDLC, in order to support this configuration.

Starting with NCP V7R7, frame-relay BAN connections can be balanced over 3745-supported DLCIs. Starting with NCP V7R8, this connection-balancing support is also available for 3746 Model 900-supported DLCIs. For more information, see the BALANCE keyword on the DLCI statement on page 16-14.

Figure 16-18 on page 16-46 shows a sample network that uses the NCP frame handler and terminating equipment functions to provide peripheral links between NCP3 and three peripheral devices:

- A link to the directly attached PS/2
- A BAN link to a remote SNA PU through a remote BAN router, such as the IBM 6611 or IBM 2210.
- A link through the frame handler function in NCP2 to IBM 3174

## Defining Frame-Relay Logical Peripheral Lines

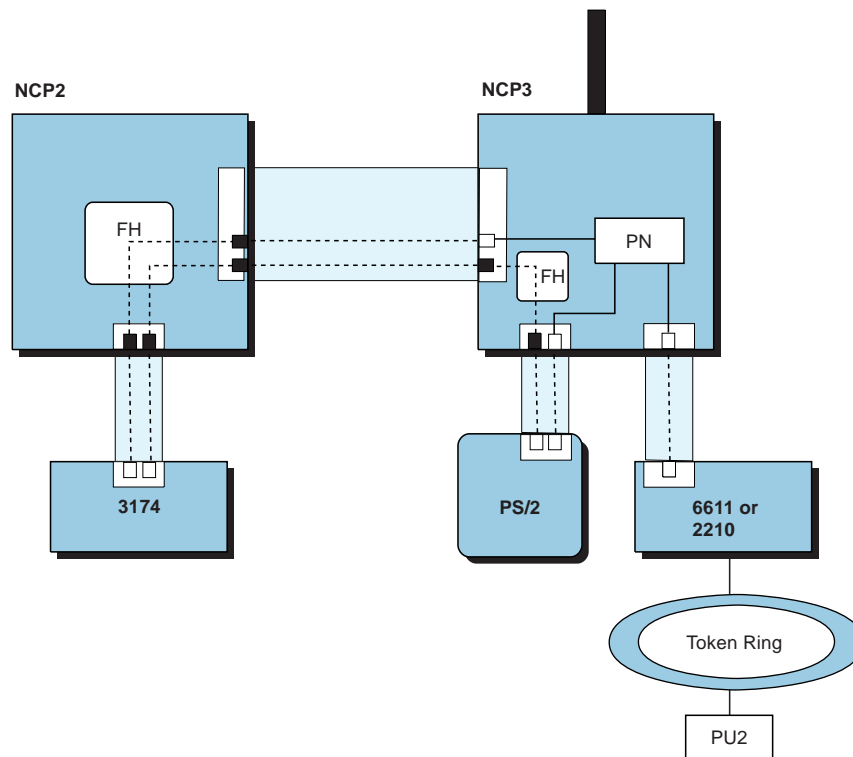

Figure 16-18. Frame-Relay Peripheral Links

The figure illustrates an important advantage of frame-relay peripheral links over SNA peripheral links: you can define a direct peripheral link between an NCP and a peripheral device not directly attached to it. To link NCP3 and IBM 3174 using SNA, you would need to do either one of the following:

- Define an explicit peripheral link between NCP3 and the IBM 3174. This would require a physical line between NCP3 and the IBM 3174.
- Route traffic over a subarea link between NCP2 and NCP3. This would require additional SNA path control processing.

The frame-relay configuration illustrated here eliminates the need for either of these additional resources.

Defining a frame-relay peripheral link is similar to defining a Token-Ring peripheral link. The frame-relay DLCI is analogous to the Token-Ring MAC address.

For a logical peripheral link, you do not explicitly define the DLCI to NCP. Instead, the DLCI is determined as follows:

- For a connection between NCP and a directly attached peripheral device as between PS/2 and NCP3 in Figure 16-18:
  - The DLCI for an incoming connection can be provided by the peripheral device. If not, DLCI X'20' is used by default.
  - The DLCI for an outgoing connection must be defined in the VTAM switched major node definition for the peripheral device.

- For a connection through a frame-relay network as between NCP3 and IBM 3174 in Figure 16-18:
  - The DLCI for an incoming connection is determined by the frame-relay network.
  - The DLCI for an outgoing connection is the DLCI of the PVC segment that connects NCP to the frame-relay network. This DLCI must be defined in the VTAM switched major node definition for the peripheral device.

For more information on defining the DLCI in the VTAM switched major node definition, see “Defining Peripheral Device Addresses to VTAM” on page 16-51.

The maximum number of peripheral link DLCIs that can be active at one time is determined by the following:

- The range of valid DLCIs is 16–991.
- The largest DLCI can be further limited by the value of MAXFRAME for the physical line; see the description of DLCI on page 16-32 for more information.
- A peripheral link cannot use a DLCI that is defined to NCP for a subarea link TESP or an FHSP.

Code the following definition statements and keywords to define frame-relay peripheral links.

BUILD	NAMTAB OWNERPL <sup>1</sup>
GROUP	AUTOGEN FRELAY PHYSRSC
LINE	LOCALTO NPACOLL RETRIES T1TIMER <sup>2</sup> T2TIMER
PU	ANS COMRATE NPACOLL PUTYPE
<sup>1</sup> Supported starting with NCP V7R6. <sup>2</sup> Supported starting with NCP V7R3.	

### BUILD

NAMTAB on the BUILD definition statement specifies how many entries the network names table is to contain. For an Advanced Peer-to-Peer Networking (APPN) network, the value for NAMTAB must be large enough to allow multiple and parallel sessions among independent logical units.

## Defining Frame-Relay Logical Peripheral Lines

OWNERPL on the BUILD definition statement specifies whether unassigned logical frame-relay resources will be managed in owner-based pools. See “Unassigned Logical Line Pools” on page 16-50 for more information.

### GROUP

AUTOGEN on the GROUP definition statement specifies how many LINE and PU definition statement pairs are to be automatically generated under the GROUP definition statement. AUTOGEN is valid only when you define logical peripheral lines. For an alternative to AUTOGEN, see “Autocopy Function” on page 2-12.

FRELAY defines a frame-relay line group. Code  
FRELAY=(LOGICAL,PERIPHERAL) to define a group of frame-relay logical peripheral lines.

PHYSRSC associates a group of logical lines with a specific physical line, or it defines a group of unassigned logical lines that can be dynamically associated with a physical line:

- To associate a group of logical peripheral lines with a specific physical line, PHYSRSC must specify the name of the PU definition statement for the link-station support on the physical line. A logical line associated with a specific physical line cannot be used for a connection over any other physical line. Unlike Token-Ring logical lines, a frame-relay logical line associated with a specific physical line cannot be used for dial-out connections on another physical line.
- To define a group of unassigned logical peripheral lines, code  
PHYSRSC=NONE or PHYSRSC=(NONE,ODLC). See “Unassigned Logical Line Pools” on page 16-50 for more information.

### LINE

NPACOLL specifies whether the link is to be eligible for NPM performance data collection. Frame-relay logical lines use extended format COLLECT request/response units.

RETRIES specifies how many attempts NCP is to make to recover from errors that occur during transmission over a link.

LOCALTO and, starting with NCP V7R3, T1TIMER specify the T1 (reply) timer interval for a local link. It is important to code a value for T1TIMER or LOCALTO that reflects the maximum amount of time that it takes to receive a solicited response from the adjacent link station. Factors that can affect this time include line speed, propagation delay, maximum frame size, delay caused by intermediate frame handlers, and the number of DLCIs supported by the associated physical line that could create queuing delays for the FRTEs. If the value you code for T1TIMER or LOCALTO is too small, the FRTEs can lose synchronization and fail the connection. This is indicated by an INOP 01 and a link event or an alert that indicates a frame reject (FRMR) condition. If this occurs, code a larger T1TIMER or LOCALTO value for this FRTE connection. See “Determining a T1 (Reply) Timer Value for a Local Link” on page 16-36 for more information about determining a value.

T2TIMER specifies the acknowledgment (T2) timer interval and I-frame count for a link. NCP sends an acknowledgment when the T2 timer interval expires or when the number of I-frames received reaches the I-frame count, whichever occurs first. For more information, see “Acknowledgment Timer” on page 6-45.

### PU



Code one PU definition statement to define the TESP for the peripheral link. ANS on the PU definition statement specifies whether the peripheral link is to continue operating when your NCP enters automatic network shutdown. Automatic network shutdown occurs for devices started by a particular access method when NCP can no longer communicate with that access method.

COMRATE specifies whether certain frames sent over this line can be discarded by the frame-relay network to ease network congestion. Frames in a frame-relay network can be designated as discard eligible. COMRATE also specifies the relative priority among frame-relay stations (for example, FRTEs, FHSPs, and IPSPs) associated with a frame-relay port.

When the network is congested, discard eligible frames can be discarded to expedite the processing of other frames. Code COMRATE=FULL to specify that no frames are to be designated as discard eligible. Code COMRATE=NONE to cause NCP to designate all but the following frame types as discard eligible:

- S-frames (RR, RNR, and REJ), including RRs piggybacked on I-frames
- Network priority frames (VR pacing and TG sweep)
- XIDs.

To ensure equitable treatment of all traffic in the frame-relay network, choose a value for COMRATE so that NCP is consistent with the rest of the network in the use of discard eligibility. It is recommended that you code COMRATE=NONE for connections to frame-relay networks containing only nodes with NCP V6R2 or later.

### **3745 Frame Relay (NCP V7R5 or Earlier) and 3746 Model 900 Frame Relay:**

The *priority* suboperand, coded as COMRATE=(FULL,*priority*) or COMRATE=(NONE,*priority*), specifies the relative priority of an FRTE station as compared to all other associated physical stations and associated FRTE stations. The value of the *priority* suboperand of COMRATE is multiplied by the value of DATABLK on the LINE definition statement for the physical line to determine the guaranteed minimum number of bytes that a resource can transmit before a different resource must be given a transmit opportunity. (See page 16-11 for more information about the DATABLK keyword.)

The relative priority of an FRTE station can be determined as a fraction of the total available transmission time on a line that the station gets. This fraction is calculated by dividing the station's COMRATE *priority* value by the sum of the COMRATE *priority* values for all stations on the line:

$$\frac{\text{PU1's } \textit{priority} \text{ value}}{\text{Sum of } \textit{priority} \text{ values of all PUs on or associated with the physical line}}$$

For example, if there are three PUs for a line, PU1's transmission fraction is determined like this:

$$\frac{\text{PRIORITY}_{\text{PU1}}}{\text{PRIORITY}_{\text{PU1}} + \text{PRIORITY}_{\text{PU2}} + \text{PRIORITY}_{\text{PU3}}}$$

Where PRIORITY = the value of the respective PU's *priority* suboperand of the COMRATE keyword.

**3745 Frame Relay (NCP V7R6 and later releases):** The *priority* suboperand, coded as COMRATE=(FULL,*priority*) or COMRATE=(NONE,*priority*), speci-

## Defining Frame-Relay Logical Peripheral Lines

fies the relative priority of an FRTE station as compared to all other FRTE stations associated with the same physical line. The value of the *priority* suboperand of COMRATE is multiplied by the value of DATBLK on the LINE definition statement for the physical line to determine the guaranteed minimum number of bytes that a resource can transmit before a different resource must be given a transmit opportunity. (See page 16-11 for more information about the DATBLK keyword.)

The relative priority of an FRTE station can be determined as a fraction of the total available bandwidth afforded the SNA protocol that the station receives. This fraction is calculated by dividing the FRTE station's COMRATE *priority* value by the sum of the COMRATE *priority* values for all FRTE stations associated with the line:

$$\frac{\text{FRTE PU1's } \textit{priority} \text{ value}}{\text{Sum of } \textit{priority} \text{ values of all FRTE PUs associated with the physical line}}$$

For example, if three FRTE PUs are associated with a physical line, PU1's transmission fraction of the SNA protocol's total bandwidth is determined like this:

$$\frac{\text{PRIORITY}_{\text{PU1}}}{\text{PRIORITY}_{\text{PU1}} + \text{PRIORITY}_{\text{PU2}} + \text{PRIORITY}_{\text{PU3}}}$$

Where PRIORITY = the value of the respective PU's *priority* suboperand of the COMRATE keyword.

In addition to using the COMRATE keyword to specify *priority* values for FRTE stations, you can use the FRRATES keyword to specify a *priority* value for the SNA protocol. See page FRRATES on the LINE Definition Statement on page 16-11.

NPACOLL specifies whether the link station is to be eligible for performance data collection by the network performance analyzer.

PUTYPE specifies the type of physical unit being defined. Code PUTYPE=2 for a peripheral link.

## Unassigned Logical Line Pools

In certain environments, it can be advantageous to define a pool of logical peripheral lines that are not assigned to physical lines but are assigned as needed. Call-in connections on peripheral lines use assigned logical lines before using the unassigned logical lines.

3745 and 3746 Model 900 frame-relay connections have separate unassigned logical line pools. Code PHYSRSC=NONE on the GROUP definition statement to define an unassigned logical line pool for 3745 frame-relay lines. Code PHYSRSC=(NONE,ODLC) on the GROUP definition statement to define an unassigned logical line pool for 3746 Model 900 frame-relay lines.

### Allocating Unassigned Logical Line Pools to Owners

In a multiple-owner environment (for example, dual CMCs), it might be advantageous to have multiple unassigned logical line pools that are based on the owning SSCP. To do this, you must:

1. Allocate each physical line to a specific owner by coding the VTAM-only OWNER keyword for each physical line with one and only one *owner\_name*.
2. Allocate each logical pool to a specific owner by coding the VTAM-only OWNER keyword for each logical pool.
3. Code the OWNERPL keyword on the BUILD statement.

This function will control call-in connections. An unassigned logical resource will be used for an incoming call only if the logical resource has the same owning SSCP as the physical line over which the call was made. If there are no logical resources available with the same owning SSCP, an incoming call cannot be established. Even when this function is genned, assigned logical lines continue to be used before the unassigned logical lines.

To create the owner-based unassigned logical pools for 3745 frame-relay resources, code FR on OWNERPL. To create the owner-based unassigned logical pools for 3746 Model 900 frame-relay resources, code ODLCFR on OWNERPL.

## Defining Peripheral Device Addresses to VTAM

When you are defining a switched major node to VTAM that uses a frame-relay logical peripheral line, if the connection to the frame-relay device will be initiated by VTAM, you need to specify dial information to enable VTAM to initiate the connection. There are two ways to do this:

- For VTAM V4R1 and earlier, code the VTAM DIALNO keyword on the VTAM PATH definition statement.
- For VTAM V4R2 or later, you can code the DIALNO keyword or the DLCADDR keyword on the VTAM PATH definition statement.

**Note:** Starting with NCP V7R4, you can dial out to a frame-relay BAN-attached device, using the DIALNO encoding, in the VTAM switched major node. With NCP V7R3 and earlier, you cannot dial out to a frame-relay BAN-attached device, using the DIALNO encoding, in the VTAM switched major node. You must use DLCADDR encoding to dial out to a BAN-attached device.

The remainder of this section describes how to code the VTAM DIALNO and DLCADDR keywords.

### VTAM DIALNO keyword

Use the following format when coding DIALNO for dialing out to a frame-relay device:

```
DIALNO=aabb00000000cccc or DIALNO=aaXbb00000000cccc
```

where:

- aa** is the port number specified with the PORTADD keyword of the frame-relay link, in decimal.
- bb or Xbb** is the remote station's service access point (SAP), in decimal (bb) or hexadecimal (Xbb).

## Defining Frame-Relay Logical Peripheral Lines

**cccc** is the data link connection identifier (DLCI) for the connection, in hexadecimal.

For frame-relay BAN-attached devices, you must also specify the remote MAC address for the BAN station, in hexadecimal, as shown by **dddddddddddd** in the following format:

DIALNO=aabb00000000ccccdddddddddd or DIALNO=aaXbb0000000ccccdddddddddd

The MAC address must be in the range of 1 to X'7FFF FFFF FFFF'.

For more information, refer to the description of DIALNO for the switched major node definition in *VTAM Resource Definition Reference*.

### VTAM DLCADDR keyword

A frame-relay data link control (DLC) address for an SNA peripheral resource has these elements:

1. DLC type
2. Port number
3. Destination service access point (DSAP)
4. DLCI of the frame-relay PVC.
5. Source service access point (SSAP) (optional)
6. Destination MAC address (if BAN-attached)

Code a DLCADDR keyword for each element.

For the DLCADDR keyword value:

- The first suboperand indicates which element you are defining.
- The second suboperand indicates the format of the third suboperand (C=character, D=decimal, and X=hexadecimal).
- The third suboperand defines the value of the element.

Code the DLCADDR keyword as follows:

1. To specify a DLC type of frame relay, code:

DLCADDR=(1,C,FRELAY) or DLCADDR=(1,C,FRPVC)

2. To identify the port number of the frame-relay physical line, code:

DLCADDR=(2,D,nn)

where *nn* is the decimal number corresponding to the value you code for PORTADD on the LINE definition statement.

3. To specify the DSAP, code:

DLCADDR=(3,D,nn) or DLCADDR=(3,X,hh)

where *nn* and *hh* are the SAP of the remote frame-relay device, in decimal and hexadecimal, respectively.

4. To specify the DLCI of the frame-relay PVC, code:

DLCADDR=(4,D,nnn) or DLCADDR=(4,X,hhh)

where *nnn* and *hhh* are the DLCI of the remote frame-relay device, in decimal and hexadecimal, respectively. The range for *nnn* is 16 to 991, and the range for *hhh* is X'10' to X'3DF'.

5. To specify the SSAP, code:

## Defining Frame-Relay Logical Peripheral Lines

DLCADDR=(5,D,nn) or DLCADDR=(5,X,hh)

where *nn* and *hh* are the SAP of the source NCP, in decimal and hexadecimal, respectively. If you choose to specify the SSAP, you must specify a SAP of 04 for NCP dial processing.

6. To specify the destination MAC address for BAN, code:

DLCADDR=(6,X,hhhhhhhhhhhh)

where *hhhhhhhhhhhh* is the destination MAC address of the BAN-attached peripheral device on the LAN which connects it to the remote BAN router. The MAC address must be in the range of 1 to X'7FFF FFFF FFFF'.

For example, suppose you need to make outgoing connections to a peripheral device using a frame-relay PVC with a DLCI of X'20' and a DSAP of 8, and the frame-relay physical line supporting the PVC is identified by port number 45. To specify this information using the DLCADDR keyword, code:

```
DLCADDR=(1,C,FRELAY),      A frame-relay switched connection
DLCADDR=(2,D,45),          Frame-relay port 45
DLCADDR=(3,D,8),           DSAP 8
DLCADDR=(4,X,20)           DLCI of PVC (X'20')
```

For more information on the VTAM PATH definition statement and DLCADDR keyword, refer to *VTAM Resource Definition Reference*.

## NDF-Added Keywords for Frame-Relay Logical Peripheral Lines

When you define frame-relay logical peripheral lines, NDF adds the following keywords to your generation definition if you do not code them.

GROUP	COMPOWN=YES,	3745 frame relay only
	COMPSWP=NO,	3745 frame relay only
	DIAL=YES,	
	LEVEL2=ECLNAVL2,	3745 frame relay only
	LEVEL3=ECLNAVL3,	3745 frame relay only
	LEVEL5=NCP,	3745 frame relay only
	LINEADD=NONE,	3745 frame relay only
	LINEAUT=YES,	3745 frame relay only
	LNCTL=SDLC,	
	NPACOLL=(YES,EXTENDED),	1
	PUTYPE=2,	
	RETRIES=(6,0,0),	
	XMITDLY=NONE,	3745 frame relay only
	TYPE=NCP,	
	XIO=(ECLNAVXL,ECLNAVXS,ECLNAVXI,ECLNAVXX)	3745 only
LINE	UACB=X\$L <sub>n</sub> B 2	3745 frame relay only
PU	NPACOLL=NO 1	3745 frame relay only
GENEND	INIT=ECLINIT,	3745 frame relay only
	TMRTICK=ECLTICK,	3745 frame relay only
	UGLOBAL=ECLUGBL	3745 frame relay only

<sup>1</sup> Added if NPA=YES on the BUILD definition statement.  
<sup>2</sup> *n* is a counter that is incremented for each logical line.

Figure 16-19. NDF-Added Keywords for Frame-Relay Logical Peripheral Lines

### Sample Definitions of Frame-Relay Peripheral Links

This section illustrates two different frame-relay peripheral link configurations:

- A peripheral link to a device directly attached to NCP
- A peripheral link to a device attached to NCP through a frame-relay network.

#### Peripheral Link to a Directly Attached Device

Figure 16-20 illustrates a frame-relay peripheral link between NCP and a directly attached IBM 3174. In this configuration, the physical line does not need to support subarea links or FHSP connections.

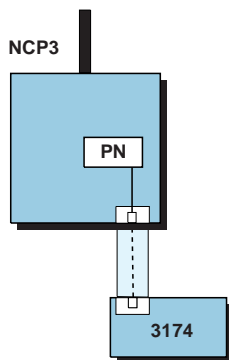

Figure 16-20. Frame-Relay Peripheral Link to a Directly Attached Device

Figure 16-21 on page 16-55 shows how to define the physical line and associated logical line for the peripheral link shown in Figure 16-20. The physical line in this example does not support subarea links (FRELAY=(PHYSICAL,PERIPHERAL) on the GROUP definition statement).

**3746 Model 900:** 3746 Model 900 physical lines always support both subarea and peripheral links. However, you can code the PERIPHERAL or SUBAREA operands.

```

*****
* NCP3 - PHYSICAL LINE GROUP
*****
PGRP3  GROUP  FRELAY=(PHYSICAL,PER) Physical peripheral line
*
PHYLP3 LINE  ADDRESS=(032,FULL), TSS adapter address is 32
MAXFRAME=2106, Maximum frame size
NRZI=YES, NRZI mode. The default is NO
PORTADD=32, Port number is 32
SPEED=9600, Line speed
DATABLK=4096
*
PHYPP3 PU  ANS=CONT, ANS=CONT added to PU by NDF
LMI=ANSI LMI support PU
.
.
*****
* NCP3 - LOGICAL LINE GROUP
*****
LGRP  GROUP  FRELAY=(LOGICAL,PER), Logical peripheral line
AUTOGEN=10, Add 10 LINE/PU pairs
CALL=INOUT, VTAM-only keyword
LOCALTO=20, Reply timer value
PHYSRSC=PHYPP3 Associated with physical PU

```

Figure 16-21. Example: Defining a Frame-Relay Peripheral Link to a Directly Attached Device

## Peripheral Link to a Device Attached through a Frame-Relay Network

Figure 16-22 illustrates a frame-relay peripheral link between NCP3 and an IBM 3174 through a frame-relay network (the frame handler function in NCP2).

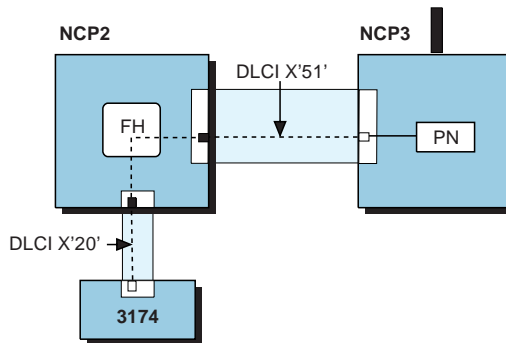

Figure 16-22. Frame-Relay Peripheral Link to a Device Attached through a Frame-Relay Network

## Defining Frame-Relay Logical Peripheral Lines

Figure 16-23 shows how to define the following for the peripheral link shown in Figure 16-22 on page 16-55:

- In NCP3, a physical line and a pool of unassigned logical lines. The physical line in this example also supports subarea links (FRELAY=(PHYSICAL,ANY) on the GROUP definition statement).
- In NCP2, the frame handler connection that supports the peripheral link. For more information, see “Defining Frame Handler Connections” on page 16-57.

**Note:** In this example, DLCI 51 needs to be defined in the VTAM switched major node definition for the IBM 3174. For more information, see “Defining Peripheral Device Addresses to VTAM” on page 16-51.

```

*****
*                               NCP3                               *
*                               *                                   *
* NCP3 - PHYSICAL LINE GROUP                                       *
*****
PGRP3  GROUP  FRELAY=(PHYSICAL,ANY) Physical line group          *
*
PHYLPA3 LINE  ADDRESS=(1028,FULL), Physical line at address 1028 *
                                CLOCKNG=EXT, External clocking    *
                                SPEED=1544000, Line speed         *
                                MAXFRAME=2106, Maximum frame size *
                                DATABLK=4096
*
PHYPPA3 PU    LMI=ANSI          LMI subport PU
*
*****
* NCP3 - LOGICAL LINE GROUP                                       *
*****
LGRP3  GROUP  FRELAY=(LOGICAL,PERIPHERAL), Log. per. line group *
                                PHYRSRC=PHYPPA3 Associated with physical PU
*
LOGLPA3 LINE
*
LOGPPA3 PU    PUTYPE=2          Peripheral link

```

Figure 16-23 (Part 1 of 2). Example: Defining a Frame-Relay Peripheral Link to a Device Attached through a Frame-Relay Network



```

*****
*                               NCP2                               *
*                               *                                 *
* NCP2 - PHYSICAL LINE GROUP                                     *
*****
PGRP2  GROUP  FRELAY=(PHYSICAL,ANY) Physical line group
*
C04F1032 LINE  ADDRESS=(1032,FULL), Physical line at address 1032 *
                CLOCKNG=EXT,      External clocking          *
                SPEED=1544000,     Line speed                  *
                MAXFRAME=2106,     Maximum frame size
                DATABLK=4096
*
C04P1032 PU    LMI=CCITT           LMI subport
*
C04P32B  PU    DLCI=(51,H)         FHSP for DLCI X'51'
*
C04F1036 LINE  ADDRESS=(1036,FULL), Physical line at address 1036 *
                CLOCKNG=EXT,      External clocking          *
                SPEED=1544000,     Line speed                  *
                MAXFRAME=2106,     Maximum frame size
*
C04P1036 PU    LMI=CCITT           LMI subport
*
C04P36B  PU    DLCI=(20,H)         FHSP for DLCI X'20'
*****
* NCP2 - FRAME-HANDLER CONNECTION BETWEEN DLCI X'51' AND DLCI X'20' *
*****
FRFH2  FRSESET SUBPORTS=(C04P32B,C04P36B)

```

Figure 16-23 (Part 2 of 2). Example: Defining a Frame-Relay Peripheral Link to a Device Attached through a Frame-Relay Network

## Defining Frame Handler Connections

The NCP frame handler function enables you to create your own frame-relay network, or to create a hybrid network with a public frame-relay service provider. Figure 16-1 on page 16-3 shows an NCP frame-relay network in which the frame handler function provides links between subareas and peripheral devices that are not directly attached.

**Note:** Frame handler function is also supported over NTRI between NCPs. For more information, see “Defining NTRI Attachments for a Frame-Relay Network” on page 16-63.

You can attach any frame-relay terminating equipment device to an NCP frame-relay network. As a result, you can use NCP to provide reliable communication between FRTEs. Figure 16-24 on page 16-58 shows a sample network in which two frame-relay physical lines between two NCPs provide redundant frame-relay connections between a PS/2 and an IBM 3174. If the primary path between NCP1 and NCP2 (DLCI X'51') fails, traffic is automatically switched to the substitute path (DLCI X'61').

## Defining Frame Handler Connections

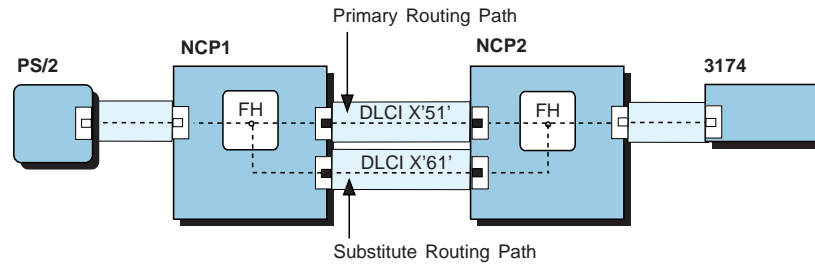

Figure 16-24. Reliable Frame Handler Transport between Frame-Relay Terminating Equipment Devices

To enable NCP to function as a frame handler in a frame-relay network, you need to define internal PVC segments between FHSPs on separate physical lines. This enables NCP to switch frames between the external PVC segments attached to the FHSPs. Figure 16-1 on page 16-3 identifies internal and external PVC segments connecting FHSPs in two NCPs. Starting with NCP V7R4, you can also define an internal PVC segment between NCP and a 3746 Model 900. This capability enables internal frame switching between the NCP and 3746 Model 900.

To enable NCP to function as a frame handler in a Token-Ring network, you need to define a frame-relay station on the Token-Ring physical line. Refer to “Defining NTRI Attachments for a Frame-Relay Network” on page 16-63 for additional information.

FHSPs are defined by PU definition statements under the LINE definition statement for the physical line. (For more information, see “Defining Frame-Relay Physical Lines” on page 16-8.) Each FHSP has a DLCI that is unique to the physical line.

The internal PVC segment between a pair of FHSPs is defined by the FRSESET definition statement. The FRSESET definition statement also defines an optional substitute FHSP for each end of the PVC segment. If either of the primary FHSPs is not available, NCP switches to the corresponding substitute FHSP. (This provides the automatic backup function illustrated in Figure 16-24.) If *both* primary FHSPs are unavailable, the internal PVC segment cannot be used.

**Note:** You can use the permanent dynamic reconfiguration function of VTAM V4R1 and later to add FHSPs and internal PVC segments between FHSPs. See “Dynamic Reconfiguration” on page 16-61 for more information.

Code the following definition statements and keywords to define FHSPs and the internal PVC segments between them.

PUDRPOOL	FRSEDRPU
PU	ADDR or DLCI <sup>1</sup> COMRATE <sup>1</sup> MAXOUT NPACOLL XMONLNK
FRSESET	SUBPORTS

<sup>1</sup> Supported starting with NCP V7R3. DLCI is valid only with VTAM V4R3 or later releases.

## PUDRPOOL

FRSEDRPU on the PUDRPOOL definition statement specifies the total number of FHSPs that can be added through dynamic reconfiguration and how many FHSPs added through dynamic reconfiguration are to be eligible for NPM performance data collection. FRSEDRPU is valid only when your NCP includes NPM data collection. For more information, see “Network Performance Data Collection” on page 24-16.

**3746 Model 900:** 3746 Model 900 frame-relay resources do not use the storage reserved by FRSEDRPU. Therefore, do not include these resources when calculating the value of FRSEDRPU.

## PU

The first PU definition statement under the LINE definition statement for the physical line defines the link-station subport. Subsequent PU definition statements define FHSPs.

ADDR on the PU definition statement for an FHSP defines the DLCI of the FHSP. To specify addressing greater than X'FE', use the DLCI keyword. ADDRs for FHSPs have the same restrictions as ADDRs for subarea link TESP. For any adapter line (TSS, HSS, or 3746 Model 900), you can use ADDRs X'10'–X'FE'.

DLCI on the PU definition statement for an FHSP defines the data link connection identifier of the FHSP. You can also specify the DLCI using the ADDR keyword. DLCIs for FHSPs have the same restrictions as DLCIs for subarea link TESP. For any adapter line, you can use DLCIs X'10'–X'3DF' (16–991 in decimal). See the description of DLCI on page 16-32 for more information on defining DLCIs.

**3745 Frame Handler Connections (NCP V7R5 or Earlier) and 3746 Model 900 Frame Handler Connections:** The *priority* suboperand, coded as COMRATE=(,*priority*), specifies the relative priority of an FHSP station as compared to all other associated physical stations and associated logical lines. The value of the *priority* suboperand of COMRATE is multiplied by the value of DATBLK on the LINE definition statement to determine the guaranteed minimum number of bytes that a resource can transmit before a different resource must be given a transmit opportunity. (See page 16-11 for more information about the DATBLK keyword.)

The relative priority of an FHSP station can be determined as a fraction of the total available transmission time on a line that the station gets. This

## Defining Frame Handler Connections

fraction is calculated by dividing the station's COMRATE *priority* value by the sum of the COMRATE *priority* values for all stations on the line:

$$\frac{\text{PU1's } \textit{priority} \text{ value}}{\text{Sum of } \textit{priority} \text{ values of all PUs on or associated with the physical line}}$$

For example, if there are three PUs for a line, PU1's transmission fraction is determined like this:

$$\frac{\text{PRIORITY}_{\text{PU1}}}{\text{PRIORITY}_{\text{PU1}} + \text{PRIORITY}_{\text{PU2}} + \text{PRIORITY}_{\text{PU3}}}$$

Where PRIORITY = the value of the respective PU's *priority* suboperand of the COMRATE keyword.

**3746 Model 900-Attached Frame Relay Lines:** For an alternative way of managing bandwidth, see the description of the CIR keyword on the LINE definition statement in the *Resource Definition Reference* manual.

**3745 Frame Handler Connections (NCP V7R6 and later releases):** The *priority* suboperand, coded as COMRATE=(,*priority*), specifies the relative priority for an FHSP station as compared to all other FHSP stations associated with the same physical line. The value of the *priority* suboperand of COMRATE is multiplied by the value of DATBLK on the LINE definition statement for the physical line to determine the guaranteed minimum number of bytes that a resource can transmit before a different resource must be given a transmit opportunity. (See page 16-11 for more information about the DATBLK keyword.)

The relative priority of an FHSP station can be determined as a fraction of the total available bandwidth afforded the frame-handler protocol that the station receives. This fraction is calculated by dividing the FHSP station's COMRATE *priority* value by the sum of the COMRATE *priority* values for all FHSP stations associated with the line:

$$\frac{\text{FHSP PU1's } \textit{priority} \text{ value}}{\text{Sum of } \textit{priority} \text{ values of all FHSP PUs associated with the physical line}}$$

For example, if three FHSP PUs are associated with a physical line, PU1's transmission fraction of the frame-handler protocol's total bandwidth is determined like this:

$$\frac{\text{PRIORITY}_{\text{PU1}}}{\text{PRIORITY}_{\text{PU1}} + \text{PRIORITY}_{\text{PU2}} + \text{PRIORITY}_{\text{PU3}}}$$

Where PRIORITY = the value of the respective PU's *priority* suboperand of the COMRATE keyword.

In addition to using the COMRATE keyword to specify *priority* values for FHSP stations, you can use the FRRATES keyword to specify a *priority* value for the frame-handler protocol. See FRRATES on the LINE Definition Statement on page 16-11.

MAXOUT defines a limit on the number of frames in the outbound queue for an FHSP. MAXOUT defines two congestion thresholds:

- Mild congestion is indicated at 50% of the MAXOUT value. At this level, NCP sets the backward explicit congestion notification (BECN) and forward explicit congestion notification (FECN) indicators in transmitted frames.
- Severe congestion is indicated at 100% of the MAXOUT value. At this level, NCP discards frames to be transmitted through the FHSP instead of placing them in the outbound queue.

NPACOLL specifies whether the FHSP is to be eligible for NPM performance data collection.

XMONLNK specifies whether SMMF can activate a link station when NCP is not in session with an SSCP on the link. If you code XMONLNK=YES for an FHSP, also code XMONLNK=YES for the link-station subport.

### FRSESET

The FRSESET definition statement defines a path between two external PVC segments. It does this by defining an internal PVC segment between the NCP FHSPs at the end of each external PVC segment.

SUBPORTS on the FRSESET definition statement specifies the two FHSPs to be connected by the internal PVC segment. SUBPORTS also specifies an optional substitute FHSP for each end of the PVC segment. An FHSP can be the end point of only one internal PVC segment, so do not specify the same FHSP more than once, either on one SUBPORTS keyword or on more than one SUBPORTS keyword.

**Note:** For NCP V7R2 and NCP V7R3, defining an internal PVC segment between a 3745 FHSP and a 3746 Model 900 FHSP is not supported. All subports specified for a given FRSESET must be either:

- TSS- or HPTSS-attached,
- NTRI-attached (introduced in NCP V7R3), or
- Attached to a 3746 Model 900 frame-relay line.

Starting with NCP V7R4, you can define an internal PVC segment between a TSS, HPTSS, or NTRI-attached FHSP and a 3746 Model 900 FHSP. In addition, you can specify a 3745 FHSP or a 3746 Model 900 FHSP as a substitute FHSP for any primary FHSP.

### Dynamic Reconfiguration

This section applies only if you are using VTAM V4R1 or later.

You can use the VTAM permanent dynamic reconfiguration function to add FHSPs and internal PVC segments between FHSPs:

- To define an FHSP, add a PU definition statement for a type 1 physical unit to the LINE definition statement for the frame-relay physical line or the NTRI frame handler logical line.
- To define an internal PVC segment between two FHSPs, add an FRSESET definition statement. On the SUBPORTS keyword, specify the names of the PU definition statements for the two FHSPs. You can also specify a substitute FHSP for each primary FHSP.

Starting with NCP V7R4, you can define an internal PVC segment between a 3746 Model 900 and an NCP running on a 3745. Add a FRSESET definition statement with a SUBPORTS keyword that contains the names of the PU defi-

## Defining Frame Handler Connections

inition statements for a 3745 FHSP and 3746 Model 900 FHSP. Also, you can specify a 3745 FHSP or a 3746 Model 900 FHSP as a substitute for either primary FHSP.

VTAM adds the new FHSPs and PVC segments to NCP when activating NCP or performing permanent dynamic reconfiguration.

## Sample Definition of Frame Handler Connections

Figure 16-25 illustrates two NCP frame handler routing paths:

- A primary path between the segments with DLCIs X'2F' and X'51'
- A substitute path between the segments with DLCIs X'2F' and X'61'.

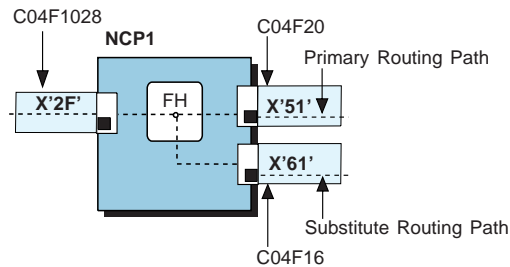

Figure 16-25. Frame-Relay Routing Paths

Figure 16-26 shows how to define the connections shown in Figure 16-25. Notice the following relationships:

- C04P28B is a subport associated with line C04F1028 with DLCI X'2F'.
- C04P20B is a subport associated with line C04F20 with DLCI X'51'.
- C04P16B is a subport associated with line C04F16 with DLCI X'61'.
- DLCIs are defined by the ADDR keywords.
- SUBPORTS on the FRSESET definition statement defines the primary internal PVC segment between FHSPs C04P28B and C04P20B.
- SUBPORTS also defines a substitute internal PVC segment between FHSPs C04P28B and C04P16B.

```

C04FRGP1 GROUP FRELAY=PHYSICAL,                                X
.
.
*****
* FRAME RELAY PHYSICAL LINE 1028 - FULL DUPLEX HPTSS          *
*****
C04F1028 LINE ADDRESS=(1028,FULL),                             *
.
.
C04P1028 PU LMI=CCITT, LMI subport                             *
.
.
C04P28B PU  DLCI=(2F,H) FHSP for DLCI X'2F'
*

```

Figure 16-26 (Part 1 of 2). Example: Defining FRFH Virtual Circuits

```

*****
* FRAME RELAY PHYSICAL LINE 20 - FULL DUPLEX 56 KB *
*****
C04F20  LINE  ADDRESS=(020,FULL), *
      .
      .
C04P20  PU    LMI=CCITT,          LMI subport *
      .
      .
C04P20B PU    DLCI=(51,H)        FHSP for DLCI X'51'
*
*****
* FRAME RELAY PHYSICAL LINE 16 - FULL DUPLEX 56 KB *
*****
C04F16  LINE  ADDRESS=(016,FULL), *
      .
      .
C04P16  PU    LMI=ANSI,          *
      .
      .
C04P16B PU    DLCI=(61,H)        FHSP for DLCI '61'.
*
*****
* FRSESET DEFINITIONS TO DEFINE PRIMARY INTERNAL PVC SEGMENT BETWEEN *
* DLCI X'2F' AND DLCI X'51' AND SUBSTITUTE SEGMENT BETWEEN DLCI X'2F *
* AND DLCI X'61' *
*****
PVCSET2 FRSESET SUBPORTS=(C04P28B,C04P20B,,C04P16B) X'2F'->X'51',X'61'

```

Figure 16-26 (Part 2 of 2). Example: Defining FRFH Virtual Circuits

---

## Defining NTRI Attachments for a Frame-Relay Network

NCP can use a NTRI-attached Token-Ring LAN as a frame-relay frame transmission medium. The frame-relay frame handler forwards frame-relay traffic through a type 1 or type 2 TIC to the next NCP frame handler.

### Defining NTRI Physical Links

Code the following definition statements and keywords to define a NTRI attachment to support frame relay.

## Defining NTRI Attachments for a Frame-Relay Network

GROUP	ADAPTER ECLTYPE
LINE	ADDRESS BEACTO DATBLK LOCADD MAXFRAME MAXTSL NPACOLL RCVBUFC TRSPEED
PU	ADDR ANS COMRATE NETWORK XMONLNK

### GROUP

ADAPTER on the GROUP definition statement defines the type of TIC in the communication controller. For frame-relay support:

- Code ADAPTER=TIC1 to define a type 1 TIC (4 Mbps).
- Code ADAPTER=TIC2 to define a type 2 TIC (4 or 16 Mbps).

The type 3 TIC does not support frame-relay traffic.

ECLTYPE identifies the type of Token-Ring resources defined by the line group. Specify ECLTYPE=(PHYSICAL,*type*) for a frame-relay attachment. The value specified for *type*, such as, SUBAREA, PERIPHERAL, or ANY, does not affect the use of the NTRI attachment for switching frame-relay frames. For more information about defining ECLTYPE for SNA logical lines, see "Defining Token-Ring Physical Connections" on page 6-6.

### LINE

ADDRESS on the LINE definition statement specifies the relative line number associated with the TIC adapter.

BEACTO identifies the beaconing timeout value, which is the length of time NCP pauses to allow a failed Token Ring to recover. If the Token Ring cannot recover from the beaconing condition before the time coded on BEACTO elapses, the logical connections over the physical line become inoperative. If the Token Ring recovers within the time coded on BEACTO, all logical connections remain operative. Refer to *NCP and EP Reference* for further information on beaconing.

**Note:** Before the beacon timer expires, an LMI threshold error might occur, resulting in the failure of the LMI and all FHSP stations on the line.

DATBLK specifies the minimum transmission bandwidth, in bytes, that can be allocated to a resource. DATBLK is used with the *priority* suboperand of the COMRATE keyword to determine a relative priority among resources. The value of the *priority* suboperand of COMRATE is multiplied by the value of DATBLK to determine the minimum guaranteed number of bytes that a resource can transmit



before a different resource must be given a transmit opportunity. See NTRI on page 6-12 for more information about the COMRATE keyword.

LOCADD identifies the 6-byte hexadecimal hardware address of the TIC that connects NCP to an IBM Token-Ring Network. For NCP V7R3 and NCP V7R4, the hardware address must be unique within the Token Ring network because duplicate LOCADDs are not allowed for physical lines supporting frame-relay traffic. Starting in V7R5, duplicate LOCADDs can be specified for physical lines with the restriction that only one of the physical lines can support frame-relay traffic. See “Duplicate TIC Addressing for NTRI Frame Handler Logical Connections” on page 6-20 for more information about duplicate TICs for frame relay.

MAXFRAME defines the maximum frame-relay size to be transmitted or received over a frame-relay interface. The MAXFRAME value coded for the physical line must be equal to or greater than all MAXFRAME values defined for any corresponding NTRI frame handler logical lines.

When a frame-relay interface is defined on the Token-Ring, the larger value of MAXFRAME and MAXTSL determines the maximum amount of data, including 802.2 LLC header and 2 byte DLCI data, that NCP can transmit over that frame-relay interface. MAXFRAME limits the largest frame that can be transmitted for a NTRI frame handler logical line over the frame-relay interface. MAXTSL limits the largest frame that can be transmitted over an SNA or IP interface.

MAXTSL specifies the maximum amount of data that NCP is to transmit in a single NTRI frame. MAXTSL has different ranges and defaults depending on ECLTYPE, ADAPTER, and TRSPEED values. (See “Frame Size” on page 6-40 for additional information on coding MAXTSL.)

NPACOLL specifies whether the NTRI physical line is eligible for performance data collection through NPM.

RCVBUFC defines the NCP buffer capacity for receiving data from an IBM Token-Ring Network during one data transfer. The RCVBUFC value must be greater than or equal to the maximum number of bytes that will be received in one data transfer operation. One data transfer operation includes the Token-Ring header, the logical link header (LLH), the transmission header, and the request/response header. The RCVBUFC minimum value is 6 times the value coded on BFRS; the RCVBUFC maximum value depends on the type of adapter. The default value assigned to RCVBUFC depends on values coded on the ADAPTER and ECLTYPE keywords. See “Frame Size” on page 6-40 for more details on how to use RCVBUFC. TRSPEED specifies the speed of data on the Token Ring in megabits per second. Note that all adapters on the same Token Ring must use the same speed.

### PU

ADDR on a NTRI physical PU specifies the address of the NTRI link station. Code ADDR=03 for a NTRI link station that supports frame-relay traffic.

ANS on the PU definition statement determines whether service to the Token Ring continues or stops when your NCP enters automatic network shutdown. Code ANS=CONTINUE to ensure link operation if NCP enters automatic network shutdown. Sessions will continue with other access methods and applications that are unaffected by the shutdown. If you code multiple PU definition statements under the same LINE definition statement, code the same value for ANS on all of the specified PU definition statements.

## Defining NTRI Attachments for a Frame-Relay Network

COMRATE on the PU definition statement specifies the relative priority of a protocol (for example, SNA, IP, or frame relay) as represented by a physical unit defined on the physical line.

Code COMRATE=(,*priority*). The value of the *priority* suboperand of COMRATE is multiplied by the value of DATBLK on the LINE definition statement to determine the guaranteed minimum number of bytes the physical units representing a protocol can transmit, before PUs representing a different protocol must be given a transmit opportunity. (See page 16-11 for more information about the DATBLK keyword.)

The relative priority of a protocol on a NTRI line can be determined as a fraction of the total available transmission time allocated to the protocol. This fraction is calculated by dividing the COMRATE *priority* value of the PU representing the protocol by the sum of the *priority* values calculated for all of the protocols represented on the line:

$$\frac{\text{Protocol 1's } \textit{priority} \text{ value}}{\text{The sum of } \textit{priority} \text{ values of all protocols on the physical line}}$$

For example, if there are three PUs for a line, PU1's transmission fraction is determined like this:

$$\frac{\text{PRIORITY}_{\text{PU1}}}{\text{PRIORITY}_{\text{PU1}} + \text{PRIORITY}_{\text{PU2}} + \text{PRIORITY}_{\text{PU3}}}$$

Where PRIORITY = the value of the *priority* suboperand of the COMRATE keyword.

NETWORK specifies whether this physical unit represents an SNA, internet, or frame-relay interface. To define Token-Ring support for frame-relay traffic, code NETWORK=FRELAY.

TGCONF specifies whether a transmission group contains one or more logical lines. Code TGCONF=SINGLE if transmission group contains only a single Token-Ring logical subarea line.

XMONLNK specifies whether SMMF can activate this link station when NCP is not in session with an SSCP on this line. When MONLINK is coded on logical line definition statements associated with a physical line, code XMONLNK=YES on at least one physical PU.

## Defining NTRI Frame Handler Logical Links

Code the following definition statements and keywords to switch frame-relay traffic to a NTRI attached Token-Ring.

BUILD	LOCALTO REMOTTO T1TIMER
GROUP	ECLTYPE PHYSRSC
LINE	COMRATE (frame handler logical lines) MAXDLCI MAXFRAME MAXPU NPACOLL RETRIES
PU(LMI)	ADDR ANS COMRATE ERRORT LMI MAXDLCI NPACOLL SPOLL SRT TIMERS XMONLNK
PU(FRFH)	ADDR or DLCI COMRATE

### BUILD

T1TIMER on the BUILD definition statement specifies the Token-Ring reply timer (T1) values for logical connections. T1TIMER is only used when NTRI frame handler logical lines are performing route determination processing. T1TIMER values, which specify the local and remote timer (T1) values, can also be specified using LOCALTO and REMOTTO keywords.

### GROUP

ECLTYPE=(LOGICAL,FRELAY) identifies the line group type for an NTRI frame handler logical line defined by the line group.

PHYSRSC associates a group of logical lines with a specific physical line. Specify the name of the PU definition statement for the link-station on the physical line (NETWORK=FRELAY).

### LINE

COMRATE specifies relative priority for a NTRI frame handler logical line as compared to all NTRI frame handler logical lines associated with the same NTRI physical line.

MAXDLCI on the LINE or PU (link-station subport) definition statement defines the maximum number of DLCIs for the NTRI frame handler logical link if LMI is not supported. The value you code should equal or exceed the expected number of DLCIs. If LMI is supported, the maximum DLCI is the smaller of:

- The largest DLCI allowed by the MAXDLCI keyword

## Defining NTRI Attachments for a Frame-Relay Network

- The value of the following expression (converted to hexadecimal):

$$((maxframe - fixed) \div 5) + 15$$

where:

*maxframe* is the value of MAXFRAME for this line.

*fixed* is 17 when LMI=CCITT or LMI=CCITT-NUI.

*fixed* is 18 when LMI=ANSI or LMI=ANSI-NUI.

MAXFRAME on the logical LINE definition statement specifies the maximum size frame-relay frame to be transmitted or received over this NTRI frame handler logical line. The value coded for MAXFRAME can not be greater than MAXFRAME on the corresponding NTRI physical link.

MAXPU defines the maximum number of FHSP physical units (including the link-station support) to be supported on the link.

NPACOLL specifies whether the link is to be eligible for NPM performance data collection. Frame-relay logical lines use extended format COLLECT request/response units.

RETRIES specifies how many attempts NCP is to make to recover from errors that occur during transmission over a link. RETRIES is only used when NTRI frame handler logical lines are performing route determination processing.

### PU

ADDR on the LMI support PU definition statement defines the one byte destination service access point and the six byte destination NCP TIC address.

**Note:** ADDR on the FRFH support PU definition statement defines the support DLCI address. To specify addressing greater than X'FE' use the DLCI keyword. See the description of DLCI under "PU" on page 16-32 for additional information.

ANS on the PU definition statement determines whether service to the Token Ring continues or stops when your NCP enters automatic network shutdown. ANS=CONTINUE is the only valid value when you define NTRI frame handler logical lines. Frame-relay switching continues over the Token-Ring, unaffected by the shutdown.

COMRATE on the PU definition statement specifies the relative priority of an FRFH support as compared to all FRFHs defined on the NTRI frame handler logical line.

Code COMRATE=(,*priority*). The value of the *priority* suboperand of COMRATE is multiplied by the value of DATBLK on the physical LINE definition statement to determine the guaranteed minimum number of bytes a FRFH can transmit before another FRFH must be given a transmit opportunity. Refer to "Defining NTRI Physical Links" on page 16-63 for additional information on using DATBLK to determine resource priority.

DLCI on the PU definition statement for an FHSP defines the data link connection identifier of the FHSP. You can also specify the DLCI using the ADDR keyword.

DLCIs for FHSPs have the same restrictions as DLCIs for subarea link TESP:

## Defining NTRI Attachments for a Frame-Relay Network

- For an NTRI frame handler logical line, you can use DLCIs X'10'–X'3DF' (16-991 in decimal).

See the description of DLCIs under “PU” on page 16-32 for more information on defining DLCIs.

MAXDLCI on the PU (link-station subport) or LINE definition statement defines the maximum number of DLCIs for the NTRI frame handler logical link if LMI is not supported. The value you code should equal or exceed the expected number of DLCIs. If LMI is supported, the maximum DLCI is the smaller of:

- The largest DLCI allowed by the MAXDLCI keyword
- The value of the following expression (converted to hexadecimal):

$$((maxframe - fixed) \div 5) + 15$$

where:

*maxframe* is the value of MAXFRAME for this line.

*fixed* is 17 when LMI=CCITT or LMI=CCITT-NUI.

*fixed* is 18 when LMI=ANSI or LMI=ANSI-NUI.

SROLL defines the frequency at which LMI full status requests are sent to the adjacent frame-relay node by the LMI subport. SROLL is not valid if you specify LMI=NO for the link-station subport.

SRT defines reporting thresholds for the number of error retries and the total number of transmissions. When either of these thresholds is reached, NCP builds an error event record using PDSTAT. The threshold is determined by the total number of LMI frames and FHSP frames sent over an NTRI frame handler logical line.

LMI specifies whether the link-station subport is to support the LMI protocol, and if so, which LMI protocol NCP is to use. If you code LMI=ANSI or LMI=CCITT, NCP determines the level of LMI support required to communicate with the adjacent frame-relay node during activation of the LMI subport. The optional echo suboperands on the LMI keyword are ignored for NTRI frame handler logical lines. The level of support used by NCP can be one of the following:

- No LMI support
- Request LMI status only
- Respond to LMI status requests only
- Bidirectional support to request LMI status and respond to LMI status requests.

The LMI standard used by the frame-relay network node at each end of a physical connection can be ANSI, the United States standard, or CCITT, the international standard. Code the first suboperand to indicate which standard is to be used by your NCP. Use the same LMI standard at both ends of a connection; mismatched LMI standards can cause an interruption in LMI processing and can prevent activation of a link.

You can request that the frame-relay interface use only the Network-to-User Interface by adding -NUI to the end of the standard suboperand (LMI=CCITT-NUI or LMI=ANSI-NUI). In this case, no discovery of the LMI support to use is performed.

## Defining NTRI Attachments for a Frame-Relay Network

TIMERS defines the LMI T391 and T392 intervals. The T391 interval is the interval between transmissions of LMI link integrity verification (LIV) status enquiry messages to the adjacent node. The T392 interval is the interval in which an LMI status enquiry message must be received before the interval is considered an error interval. Code TIMERS and ERRORT on the PU definition statement for the link-station subport to monitor the integrity of the physical line. TIMERS is not valid if you specify LMI=NO for the link-station subport.

XMONLNK specifies whether the link address is to be monitored for an Activate Physical command when NCP is not in session with an SSCP on this line. If you code XMONLNK=YES for an LMI subport, you must code XMONLNK=YES on a physical PU associated with the Token-Ring physical line.

## NDF-Added Keywords for NTRI Frame Handler Logical Lines

Figure 16-27 shows the NDF-generated keywords that are added to your generation definition if you do not code them and you define NTRI frame handler logical lines.

GROUP	COMPOWN=YES,	NTRI only
	DIAL=NO,	
	LEVEL2=ECLNAVL2,	NTRI only
	LEVEL3=ECLNAVL3,	NTRI only
	LEVEL5=NCP,	NTRI only
	LINEADD=NONE,	NTRI only
	LNCTL=SDLC,	
	NPACOLL=NO,	
	PUTYPE=1	
	RETRIES=(6,0,0,6),	
	TYPE=NCP,	
	USERID=(5668854,ECLFTDT,NORECMS,,ECLNMVT),	NTRI only
	XIO=(ECLNAVXL,ECLNAVXS,ECLNAVXI,ECLNAVXK)	NTRI only
LINE	UACB=(X\$LnA)	NTRI only <sup>1</sup>
GENEND	INIT=ECLINIT,	NTRI only
	TMRTICK=ECLTICK,	NTRI only
	UGLOBAL=ECLUGBL	NTRI only

<sup>1</sup> n is a counter that is incremented for each logical line.

Figure 16-27. NDF-Generated Keywords for Token-Ring Logical Frame-Relay Lines

## Sample Coding to Define a NTRI Frame-Relay Attachment

Figure 15-9 on page 15-36 shows a NTRI frame-relay attachment that supports both SNA and frame-relay traffic.

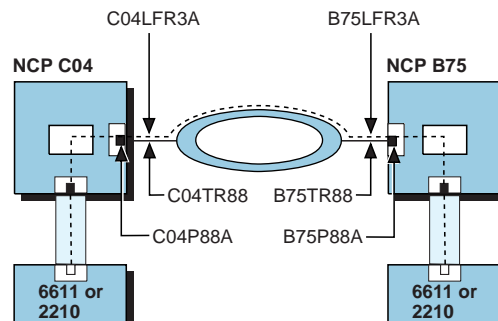

Figure 16-28. NTRI Frame Handler Attachment

## Defining NTRI Attachments for a Frame-Relay Network

Figure 16-29 on page 16-71 shows how to define the NTRI frame-relay attachment shown in Figure 16-28. The PU definition statements define the SNA and frame-relay interfaces for the Token Ring physical line.

```

*****
*      NCP TOKEN-RING INTERCONNECT PHYSICAL LINES      *
*****
*
C04NTRP1 GROUP ECLTYPE=(PHYSICAL,ANY),                *
                ANS=CONTINUE,                          *
                RETRIES=(20,5,5),                      *
                USSTAB=AUSSTAB,                       *
                XID=NO,                                *
                TYPE=NCP,                              *
                DIAL=NO,                               *
                LNCTL=SDLC,                            *
                LEVEL2=ECLNARL2,                      *
                LEVEL3=ECLNARL3,                      *
                LEVEL5=NCP,                            *
                TIMER=(ECLNART1,,ECLNART2,ECLNART3),  *
                XIO=(ECLNARXL,ECLNARXS,ECLNARXI,ECLNARXK), *
                USERID=(5668854,ECLRBDT,NORECMS,,ECLNMVT), *
                SPEED=9600,                            *
                NPACOLL=NO,                            *
                PUTYPE=1,                              *
                PUDR=NO,                               *
                COMPTAD=YES,                          *
                COMPSWP=YES,                          *
                COMPOWN=YES
*****
*      ADDRESS 1088: NTRI PHYSICAL LINE - SUBAREA/PERIPHERAL      *
*****
*
C04TR88  LINE ADDRESS=(1088,FULL),                    *
                ADAPTER=TIC2,                          *
                LOCADD=4000000C0431,                  *
                PORTADD=1,                             *
                MAXFRAME=2106,                        *
                TRSPEED=4,                             *
                UACB=(X$P1AX,X$P1AR)
*
C04PU88  PU  ADDR=01,                                *
                INNPORT=YES
*
C04PU88B PU   NETWORK=FRELAY,COMRATE=(,3),PUTYPE=1,ADDR=03
*
.           Definitions of other logical lines
.
.

```

Figure 16-29 (Part 1 of 2). Example: Defining a NTRI Frame-Relay Attachment

## 3746 Model 900 Frame Relay

```
*****
* LOGICAL DEFINITIONS FOR FRAME RELAY PORT C04PU88B *
*****
*
C04FRTG1 GROUP ECLTYPE=(LOGICAL,FRELAY),PUTYPE=1,TYPE=NCP,DIAL=NO, X
                LNCTL=SDLC,LINEADD=NONE,COMPOWN=YES,RETRIES=(6,0,0,6), X
                PHYSRSC=C04PU88B
C04LFR3A LINE MAXFRAME=2106,NPACOLL=(YES,EXTENDED),MAXPU=240, X
                COMRATE=(,1)
C04LM88A PU LMI=ANSI,ANS=CONT,ADDR=C4400000007531
*
C04P88A PU DLCI=(96,D), *
                NPACOLL=(YES,EXTENDED), *
                INNPORT=YES, *
                ANS=CONTINUE
*
C04P88B PU DLCI=(97,D), *
                NPACOLL=(YES,EXTENDED), *
                INNPORT=YES, *
                ANS=CONTINUE
*
*
* FRSE PU TO BE ADDED USING VTAM 4.1 PERM DR
*C04P88D PU ADDR=62
*
*****
* FRSESET DEFINITIONS *
*****
PVCSET1 FRSESET SUBPORTS=(C04P28A,C04P88A,,C04P16A)
PVCSET2 FRSESET SUBPORTS=(C04P28B,C04P88B,,C04P16B)
PVCSET3 FRSESET SUBPORTS=(C04P28C,C04P16C)
* FRSESET TO BE ADDED USING VTAM 4.1 PERM DR
*
*
```

Figure 16-29 (Part 2 of 2). Example: Defining a NTRI Frame-Relay Attachment

## 3746 Model 900 Frame Relay

Attaching frame-relay lines to the 3746 Model 900 connectivity subsystem improves NCP performance because the 3746 Model 900 takes over the data link control function from NCP. Frame-relay support for the 3746 Model 900 is the same as frame-relay support for TSS or HPTSS links, with these exceptions:

- The PHYSRSC keyword should be coded as PHYSRSC=(NONE,ODLC) to define a pool of unassigned peripheral logical lines on the 3746 Model 900.
- The ADDRESS keyword on the LINE definition statement must be valid for the 3746 Model 900; it must be greater than 2080.
- The PORTADD keyword is required and has a valid range of 0–254.
- With NCP V7R2 and NCP V7R3, a TSS FHSP, HPTSS FHSP, or NTRI logical FHSP and a 3746 Model 900 FHSP cannot form an internal PVC segment. Starting with NCP V7R4, a TSS, HPTSS, or NTRI frame handler FHSP and a 3746 Model 900 FHSP can form an internal PVC segment. This capability enables internal frame switching between an NCP and 3746 Model 900.
- The CIR keyword can be specified for the 3746 Model 900 (but not for 3745 frame relay).



- The FRRATES keyword cannot be specified for the 3746 Model 900.

**Note:** 3745 and 3746 Model 900 lines must be defined under different GROUP definition statements.

See “Frame-Relay Network with 3746 Model 900” on page 16-85 and Appendix A, “NCP V7R8 Sample Generation Definitions” on page A-1 for sample NCP definitions for a network with 3746 Model 900 frame-relay connections.

---

## Remote Loading and Activation over a Frame-Relay Line

You can use a frame-relay subarea link to load an NCP load module into a remote communication controller containing an active NCP, and then activate the new NCP through SMMF. To do this, the active NCP in the remote controller must include a frame-relay subarea link defined with:

- XMONLNK=YES on the PU definition statement for the physical line
- IPL=YES and MONLINK=YES on the LINE definition statement for the logical subarea line.

Be sure that the LMI error threshold time interval for the link-station subport in the remote NCP is at least 3 times the T1 (reply) timer interval for the logical subarea line in the local NCP, particularly if the two NCPs are communicating through an NCP frame-relay network. These time intervals are defined as follows:

- The LMI error threshold time interval is  $T391 \times N392$ , where  $T391$  is a time interval defined by TIMERS on the PU definition statement for the link-station subport, and  $N392$  is an error count threshold defined by ERRORRT on the same PU definition statement.
- The T1 timer interval is defined by LOCALTO or T1TIMER (V7R3 or later) on the LINE definition statement for the logical subarea line.

For NCP V7R2 and earlier releases, if you code the time intervals as described, NCP will issue a +RSP(IPLFINAL) to VTAM to indicate that the load is complete. Because the remote NCP cannot respond to LMI messages during the load process, frame-relay physical lines attached to the remote NCP may become inoperative (INOP 02) after the load is complete. In this event, the operator needs to reactivate the physical lines. For NCP V7R3 and later releases, the physical line no longer INOPs. The logical FRTE line may become inoperative (INOP 02) and the LMI link-station may also become inoperative (INOP 01). In this event, the operator needs to reactivate the logical lines.

If you do not code the time intervals as just described, the LMI PU and associated logical lines over which NCP is being loaded may become inoperative (INOP 01 and INOP 02) respectively *before* NCP issues the +RSP(IPLFINAL) to VTAM, that is, before the load is complete. In this event, the load will fail.

Remote loading over frame-relay subarea links associated with a switched frame-relay physical line is not recommended because the physical line might inop as a result of the switched link failing (remote controller IPLing) prior to a +RSP(IPLFINAL) being received by VTAM.

For a complete description of the process for remote loading and activation, refer to *NCP, SSP, and EP Generation and Loading Guide*.

### Coding Frame-Relay Definitions for the Best Performance

There are several keywords that interact with each other to affect the performance of NCP frame-relay resources. Because of the many interactions of these performance-related keywords, you need to tune these keywords for best performance in your environment. For simple configurations with T1 and E1 speeds, the defaults of these keywords may provide good performance. For slower speeds or complex configurations, however, you need to tune some of these performance-related keywords. The following sections describe the keywords that are important to the performance of NCP frame-relay resources.

**Note:** See the *NTuneMON User's Guide* for how to interactively tune these keywords using NTuneMON.

### Performance-Related Keywords

The following keywords interact with each other to affect performance of your frame-relay network:

## Coding Frame-Relay Definitions for the Best Performance

Keyword	Definition Statement	Affected Resources	Default
DYNWIND	LINE	FRTE	(4,1,1,1,YES,1)
T2TIMER	BUILD	FRTE	(0,0,2)
DATABLK	LINE	FRTE FRFH IPSP	2048
CIR	DLCI	FRTE FRFH	(1,1,.1)
CIR	LINE	FRTE FRFH	NO
COMRATE	PU	FRTE FRFH IPSP	(,1)
FRRATES <sup>1</sup>	LINE	FRTE IPSP FRFH	(1,1,1)
COMRATE	LINE	FRTE	(FULL,1)
MAXDATA	PU	FRTE	The value of BFRS on the BUILD definition statement plus 9
MAXOUT <sup>2</sup>	PU	FRTE FRFH	8
LOCALTO	LINE	FRTE	6. Can also be coded on T1TIMER.
RETRIES	LINE	FRTE	(6,0,0)
LMI (TIMERS, ERROR)	PU	FRTE	CCITT ((10,15), (3,4))
REMOTTO	LINE	FRTE	Value of REMOTTO on the BUILD statement. Can also be coded on T1TIMER.
TITIMER	LINE	FRTE	60

<sup>1</sup> Starting in NCP V7R6, FRRATES defines the relative priority for all protocols supported by a 3745 frame-relay physical line.

<sup>2</sup> For FRTEs, MAXOUT defines the maximum number of outstanding frames. For FRFHs, MAXOUT defines the maximum number of frames that can be queued.

For simple configurations with T1 and E1 speeds, try using the defaults of these keywords. If you need to improve performance in these simple configurations with T1 and E1 speeds, try tuning the DYNWIND and T2TIMER keywords. For slower speeds and complex configurations, you must tune all of these keywords to achieve optimal performance. The easiest way to do this is with NTuneMON. See the *NTuneMON User's Guide* for detailed information about tuning your NCP.

### Tuning Performance-Related Keywords

For FRTEs that support SNA, the most important performance-related keywords are DYNWIND and T2TIMER. NTuneMON provides the easiest way to control these keywords. NTuneMON lets you measure the performance of your running NCP and interactively adjust the values you use for these keywords.

The DATABLK, COMRATE, and MAXDATA keywords work together to define the relative priority among PVCs on a line. The amount of bandwidth for each PVC is

## Coding Frame-Relay Definitions for the Best Performance

controlled by these parameters. If you use the defaults of these keywords, the PVCs on the line should receive equitable bandwidth.

The DATBLK and FRRATES keywords work together to define the relative priority among the protocols supported by a 3745 frame-relay physical line. The amount of bandwidth for each protocol is controlled by these parameters. If you use the defaults of these keywords, the bandwidth is divided equally among all the protocols supported by this line.

COMRATE and FRRATES enable you to allocate bandwidth from two different perspectives: COMRATE from the perspective of resources, FRRATES from the perspective of protocols.

**Note:** When a **protocol** has used all of its currently allocated bandwidth under FRRATES, the currently transmitting **resource** will be suspended until the next transmission opportunity, even though that resource might not have used all of its currently allocated bandwidth under COMRATE.

**3746 Model 900 Frame Relay:** Code CIR=YES to use the Model 900's Committed Information Rate (CIR) support, instead of COMRATE support, for bandwidth management. See the *3745 Communication Controller Models A; 3746 Nways Multiprotocol Controller, Models 900 and 950: Planning Guide*, GA33-0457, for more information about the Model 900 CIR processing.

MAXOUT and MODULO have a general effect on performance but do not help in fine-tuning FRTEs.

T1TIMER and RETRIES control frame recovery and line inoperative error condition timers and counts. Adjust these for timely error notifications in your environment. For simple configurations using T1 and E1 speeds, the default value of 1.5 seconds usually provides good performance and timely error detection. However, for slower speeds, the default may not work well. For example, when running at a speed of 56 Kbps, try starting with a value of 6 seconds for LOCALTO. For 9.6 Kbps, try starting with a value of 10 seconds.

ERRORT and TIMERS affect the operation of NCP during substitute subport switching. The defaults usually work well.

T1TIMER, ERRORT, and TIMERS and LMI interact for remote loading. For LMI, the T1TIMER keyword value must be coded correctly in relation to the TIMERS and ERRORT keyword values. See "Remote Loading and Activation over a Frame-Relay Line" on page 16-73 and the TIMERS keyword in the *NCP, SSP, and EP Resource Definition Reference* for more details about coding the TIMERS and ERRORT keyword values in relation to the T1TIMER keyword value.

TITIMER is an inactivity timer that causes a connection to become inoperative if the timer expires. If LMI is ANSI or CCITT, set TITIMER to its maximum value (1500).

For non-SNA FRFHs, it is easiest to control performance by adjusting the MAXOUT keyword. In general, NCP frame-relay PVCs connected to bridges or routers should have MAXOUT set to 4 rather than using the default.

FRFHs that support SNA are tuned by adjusting the SNA FRTE. When coding the FRFH, use the default for the MAXOUT keyword.

Non-SNA FRTEs are not supported in NCP.

## Sample Frame-Relay Configurations and Definitions

This section shows sample NCP network configurations and the generation definitions that define them.

- Figure 16-30 shows subarea link supports of the NCP connected to a frame-relay network.
- Figure 16-32 on page 16-78 shows a frame-relay network with two communication controllers, each running NCP V6R2 or later, that provide FRFH support.
- Figure 16-35 on page 16-82 shows how to use the same frame-relay physical connections for both FHSP and TESP connections. Connections to SNA resources require TESP; routed connections within a frame-relay network require FHSPs.
- Figure 16-38 on page 16-85 shows a frame-relay network that has a 3745 with a 3746 Model 900 that provides the FRFH and FRTE support.
- Figure 16-40 on page 16-89 shows a frame-relay network that has internal PVC segments between a 3746 Model 900 and an NCP running on a 3745.
- Figure 16-43 on page 16-93 shows a switched frame-relay physical line acting as a backup connection between an IBM 2210 Router and an IBM 3745 Communication Controller.

### Frame-Relay Network with Subarea Link Support

Figure 16-30 shows a communication controller connected to a frame-relay network. This frame-relay connection consists of one physical connection and two logical connections.

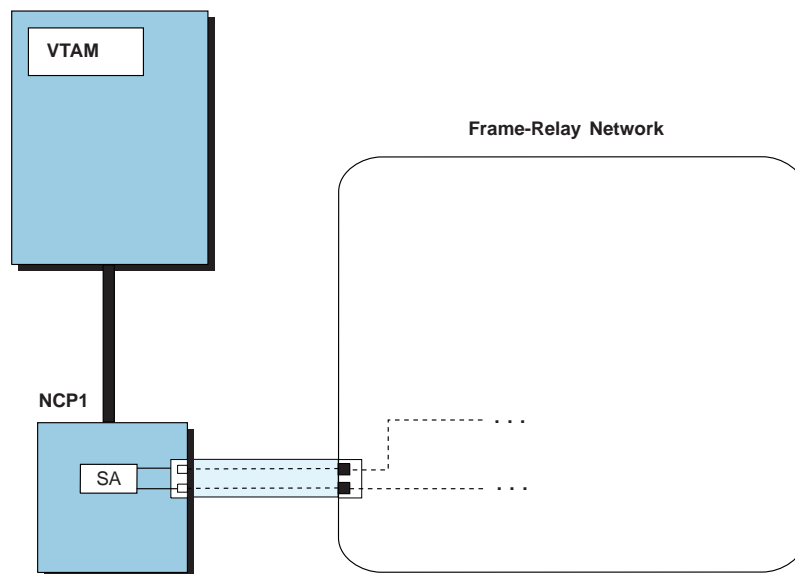

Figure 16-30. Frame-Relay Subarea Connection with TESP

## Sample Frame-Relay Definitions

Figure 16-31 shows how to define the subarea connection shown in Figure 16-30 on page 16-77.

```

PGRP3  GROUP  FRELAY=PHYSICAL      Define frame-relay physical
*
PHYLP3  LINE  ADDRESS=(1028,FULL),  HPTSS adapter address is 1028    X
          CLOCKNG=EXT,             External clocking                 X
          SPEED=1544000,           Line speed                       X
          MAXFRAME=2106            Maximum frame size
*
PHYPP3  PU
          .
          .
LGRP    GROUP  FRELAY=LOGICAL,      Define frame-relay logical lines  X
          PHYSRSC=PHYPP3,          Associate logical and physical PU X
          SDLCST=(SPRIM,SSECD)     Primary-secondary selection table
*
LLNDL25 LINE  MONLINK=YES           Include SMMF for type 4 PUs
*
LPUDL25 PU    DLCI=(19,H)           DLCI=X'19'
*
LLNDL47 LINE
*
LPUDL47 PU    DLCI=(2F,H)          DLCI=X'2F'
  
```

Figure 16-31. Example: Frame-Relay Subarea Link Connection

## Frame-Relay Network with Frame-Relay Switching Support

Figure 16-32 shows a frame-relay network with two communication controllers running NCP V6R2 or later releases. FHSPs provide logical switching connections within the network. DLCIs are shown for each of the frame-relay PVC segments.

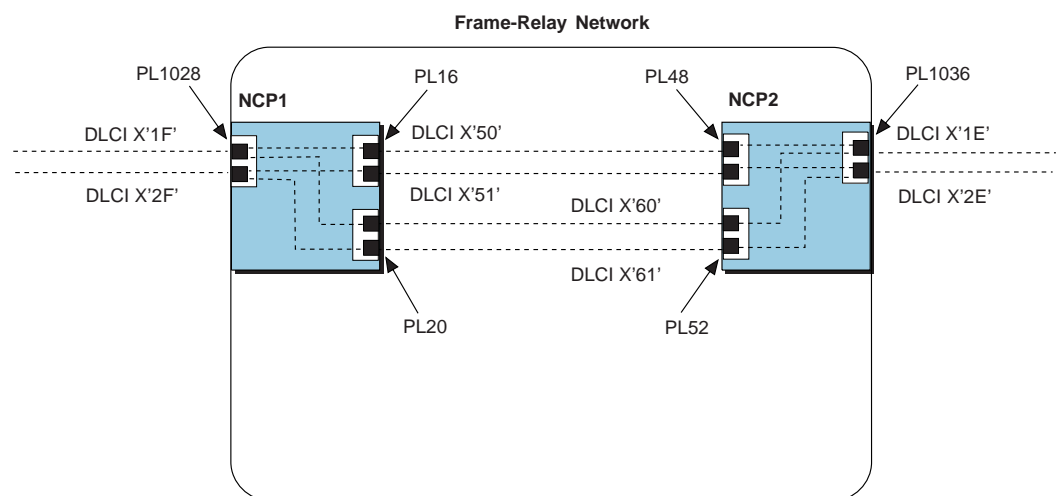

Figure 16-32. Frame-Relay Switching Network with FHSPs

Figure 16-33 and Figure 16-34 on page 16-80 show how to define the frame-relay connections in NCP1 and NCP2 shown in Figure 16-32 on page 16-78.

```

*****
*****                               N C P 1                               *****
*****
C04FRGP1 GROUP FRELAY=PHYSICAL,                                         X
                ISTATUS=ACTIVE,      VTAM-only keyword                 X
                TYPE=NCP              Automatically added by NDF
*
*****
* FRAME RELAY PHYSICAL LINE 16 - FULL DUPLEX 56 KB                       *
*****
C04F16  LINE  ADDRESS=(016,FULL),                                         *
                MAXFRAME=2106,                                           *
                CLOCKNG=EXT,                                              *
                NRZI=NO,          The default is NO                       *
                SPEED=56000
C04P16  PU    LMI=ANSI,                                                  *
                SPOLL=6,                                                 *
                ERRORT=(3,4),                                           *
                TIMERS=(10,15)
*
C04P16A PU    DLCI=(50,H)          FHSP for DLCI X'50'
*
C04P16B PU    DLCI=(51,H)          FHSP for DLCI X'51'
*
*****
* FRAME RELAY PHYSICAL LINE 20 - FULL DUPLEX 56 KB                       *
*****
C04F20  LINE  ADDRESS=(020,FULL),                                         *
                MAXFRAME=2106,                                           *
                CLOCKNG=EXT,                                              *
                NRZI=NO,          The default is NO                       *
                SPEED=56000
C04P20  PU    LMI=CCITT,          LMI subport                            *
                SPOLL=6,                                                 *
                ERRORT=(3,4),                                           *
                TIMERS=(10,15)
*
C04P20A PU    DLCI=(60,H)          FHSP for DLCI X'60'
*
C04P20B PU    DLCI=(61,H)          FHSP for DLCI X'61'
*

```

Figure 16-33 (Part 1 of 2). Example: Frame-Relay Network with FHSPs (NCP1)

## Sample Frame-Relay Definitions

```

*****
* FRAME RELAY PHYSICAL LINE 1028 - FULL DUPLEX HPTSS *
*****
C04F1028 LINE ADDRESS=(1028,FULL), *
                MAXFRAME=2106, *
                CLOCKNG=EXT, *
                NRZI=NO, The default is NO *
                SPEED=1544000
C04P1028 PU LMI=CCITT, LMI subport *
                SPOLL=6, *
                ERRORT=(3,4), *
                TIMERS=(10,15)
*
C04P28A PU DLCI=(1F,H) FHSP for DLCI X'1F'
*
C04P28B PU DLCI=(2F,H) FHSP for DLCI X'2F'
*
*****
* FRSESET DEFINITIONS *
*****
PVCSET1 FRSESET SUBPORTS=(C04P28A,C04P16A,,C04P20A) X'1F'->X'50',X'60'
PVCSET2 FRSESET SUBPORTS=(C04P28B,C04P16B,,C04P20B) X'2F'->X'51',X'61'

```

Figure 16-33 (Part 2 of 2). Example: Frame-Relay Network with FHSPs (NCP1)

```

*****
***** N C P 2 *****
*****
B75FRGP1 GROUP FRELAY=PHYSICAL, X
                ISTATUS=ACTIVE, VTAM-only keyword X
                TYPE=NCP, Automatically added by NDF
                XMONLNK=YES
*
*****
* FRAME RELAY PHYSICAL LINE 48 - FULL DUPLEX 56KB *
*****
B75F48 LINE ADDRESS=(048,FULL), *
                CLOCKNG=EXT, *
                MAXFRAME=2106, *
                NRZI=NO, The default is NO *
                SPEED=56000
B75P48 PU ERRORT=(3,4), *
                LMI=ANSI, *
                SPOLL=6, *
                TIMERS=(10,15)
*
B75P48A PU DLCI=(50,H) FHSP for DLCI X'50'
*
B75P48B PU DLCI=(51,H) FHSP for DLCI X'51'
*

```

Figure 16-34 (Part 1 of 2). Example: Frame-Relay Network with FHSPs (NCP2)



```

*****
* FRAME RELAY PHYSICAL LINE 52 - FULL DUPLEX 56KB *
*****
B75F52  LINE  ADDRESS=(052,FULL), *
          CLOCKNG=EXT, *
          MAXFRAME=2106, *
          NRZI=NO,          The default is NO *
          SPEED=56000
B75P52  PU   ERRORT=(3,4), *
          LMI=CCITT,       LMI subport *
          SPOLL=6, *
          TIMERS=(10,15)
*
B75P52A PU   DLCI=(60,H)    FHSP for DLCI X'60'
*
B75P52B PU   DLCI=(61,H)    FHSP for DLCI X'61'
*
*****
* FRAME RELAY PHYSICAL LINE 1036 - FULL DUPLEX HPTSS *
*****
B75F1036 LINE ADDRESS=(1036,FULL), *
          CLOCKNG=EXT, *
          MAXFRAME=2106, *
          NRZI=NO,          The default is NO *
          SPEED=1544000
B75P1036 PU  ERRORT=(3,4), *
          LMI=CCITT,       LMI subport *
          SPOLL=6, *
          TIMERS=(10,15)
*
B75P36A PU   DLCI=(1E,H)    FHSP for DLCI X'1E'
*
B75P36B PU   DLCI=(2E,H)    FHSP for DLCI X'2E'
*
*****
* FRSESET DEFINITIONS *
*****
PVCSET1 FRSESET SUBPORTS=(B75P36A,B75P48A,,B75P52A) X'1E'->X'50',X'60'
PVCSET2 FRSESET SUBPORTS=(B75P36B,B75P48B,,B75P52B) X'2E'->X'51',X'61'

```

Figure 16-34 (Part 2 of 2). Example: Frame-Relay Network with FHSPs (NCP2)

## Frame-Relay Network with FHSPs and TESP

Figure 16-35 on page 16-82 shows a frame-relay network containing four communication controllers. This example shows how to define the resources for NCP1 and NCP2. Because NCP1 and NCP2 include the frame handler function, they must be NCP V6R2 or later.

The connection between NCP1 and NCP2 in this example is similar to the connection in the previous example (Figure 16-32 on page 16-78); however, in this example, physical line PL48 in NCP2 is defined with both a TESP and an FHSP.

## Sample Frame-Relay Definitions

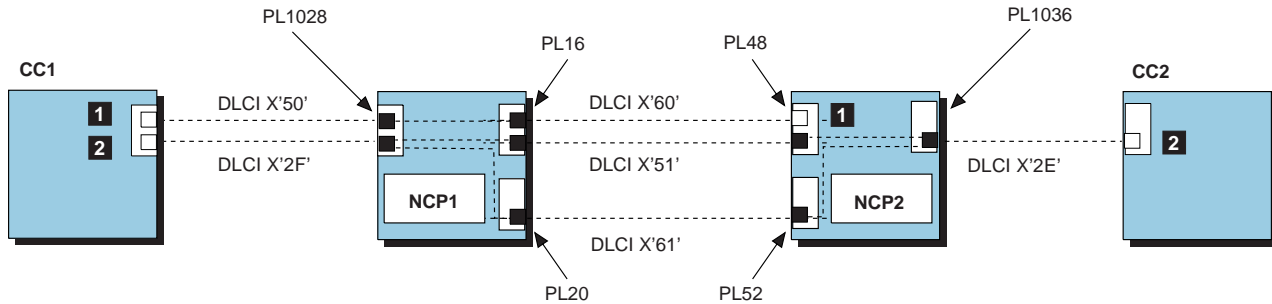

Figure 16-35. Frame-Relay Network with FHSPs and TESP

This example shows how the NCP frame handler function can provide direct subarea links between nonadjacent subareas. The figure shows two such subarea links:

- 1** The subarea link between CC1 and NCP2 passes through the frame handler function in NCP1.
- 2** The subarea link between CC1 and CC2 passes through the frame handler function in both NCP1 and NCP2. The substitute FHSPs in NCP1 and NCP2 provide an alternative path for this link.

As explained in “Defining Frame-Relay Logical Subarea Lines” on page 16-27, this technique can reduce SNA path control processing and eliminate the need to define subarea links between each pair of adjacent subareas. Figure 16-36 and Figure 16-37 on page 16-84 show how to define the configuration in Figure 16-35 for NCP1 and NCP2, respectively.

```

*****
*****          N C P 1          *****
*****
C04FRGP1 GROUP FRELAY=PHYSICAL,          X
                ISTATUS=ACTIVE,         VTAM-only keyword      X
                TYPE=NCP                 Automatically added by NDF
*

```

Figure 16-36 (Part 1 of 2). Example: Frame-Relay Network with FHSPs and TESP (NCP1)

```

*****
* FRAME RELAY PHYSICAL LINE 16 - FULL DUPLEX 56 KB
*****
C04F16  LINE  ADDRESS=(016,FULL),
                MAXFRAME=2106,
                CLOCKNG=EXT,
                NRZI=NO,           The default is NO
                SPEED=56000
C04P16  PU    LMI=ANSI,
                SPOLL=6,
                ERRORT=(3,4),
                TIMERS=(10,15)
*
C04P16B PU    DLCI=(51,H)           FHSP for DLCI X'51'
*
C04P16C PU    DLCI=(60,H)           FHSP for DLCI X'60'
*
*****
* FRAME RELAY PHYSICAL LINE 20 - FULL DUPLEX 56 KB
*****
C04F20  LINE  ADDRESS=(020,FULL),
                MAXFRAME=2106,
                CLOCKNG=EXT,
                NRZI=NO,           The default is NO
                SPEED=56000
C04P20  PU    LMI=CCITT,           LMI subport
                SPOLL=6,
                ERRORT=(3,4),
                TIMERS=(10,15)
*
C04P20B PU    DLCI=(61,H)           FHSP for DLCI X'61'
*
*****
* FRAME RELAY PHYSICAL LINE 1028 - FULL DUPLEX HPTSS
*****
C04F1028 LINE  ADDRESS=(1028,FULL),
                MAXFRAME=2106,
                CLOCKNG=EXT,
                NRZI=NO,           The default is NO
                SPEED=1544000
C04P1028 PU    LMI=CCITT,           LMI subport
                SPOLL=6,
                ERRORT=(3,4),
                TIMERS=(10,15)
*
C04P28B PU    DLCI=(2F,H)           FHSP for DLCI X'2F'
*
C04P28C PU    DLCI=(50,H)           FHSP for DLCI X'50'
*
*****
* FRSESET DEFINITIONS
*****
PVCSET2 FRSESET SUBPORTS=(C04P28B,C04P16B,,C04P20B) X'2F'->X'51',X'61'
PVCSET3 FRSESET SUBPORTS=(C04P28C,C04P16C) DLCI X'50'->X'60'

```

Figure 16-36 (Part 2 of 2). Example: Frame-Relay Network with FHSPs and TESP (NCP1)

## Sample Frame-Relay Definitions

```

*****
*****                               N C P 2                               *****
*****
*****
B75FRGP1 GROUP FRELAY=PHYSICAL,                                         X
                ISTATUS=ACTIVE,      VTAM-only keyword                 X
                TYPE=NCP,             Automatically added by NDF        X
                XMONLNK=YES

*
*****
* FRAME RELAY PHYSICAL LINE 48 - FULL DUPLEX 56KB                       *
*****
B75F48  LINE  ADDRESS=(048,FULL),                                         *
                CLOCKNG=EXT,                                               *
                MAXFRAME=2106,                                             *
                NRZI=NO,           The default is NO                       *
                SPEED=56000

B75P48  PU    ERRORT=(3,4),                                               *
                LMI=ANSI,                                                 *
                SPOLL=6,                                                 *
                TIMERS=(10,15)

*
B75P48B PU    DLCI=(51,H)          FHSP for DLCI X'51'

*
*****
* FRAME RELAY PHYSICAL LINE 52 - FULL DUPLEX 56KB                       *
*****
B75F52  LINE  ADDRESS=(052,FULL),                                         *
                CLOCKNG=EXT,                                               *
                MAXFRAME=2106,                                             *
                NRZI=NO,           The default is NO                       *
                SPEED=56000

B75P52  PU    ERRORT=(3,4),                                               *
                LMI=CCITT,        LMI subport                             *
                SPOLL=6,                                                 *
                TIMERS=(10,15)

*
B75P52B PU    DLCI=(61,H)          FHSP for DLCI X'61'

*
*****
* FRAME RELAY PHYSICAL LINE 1036 - FULL DUPLEX HPTSS                     *
*****
B75F1036 LINE ADDRESS=(1036,FULL),                                         *
                CLOCKNG=EXT,                                               *
                MAXFRAME=2106,                                             *
                NRZI=NO,           The default is NO                       *
                SPEED=1544000

B75P1036 PU    ERRORT=(3,4),                                               *
                LMI=CCITT,        LMI subport                             *
                SPOLL=6,                                                 *
                TIMERS=(10,15)

*
B75P36B PU    DLCI=(2E,H)          FHSP for DLCI X'2E'

*
*****
* FRSESET DEFINITIONS                                                    *
*****
PVCSET2 FRSESET SUBPORTS=(B75P36B,B75P48B,,B75P52B) X'2E'->X'51',X'61'
*

```

Figure 16-37 (Part 1 of 2). Example: Frame-Relay Network with FHSPs and TESP (NCP2)

```

*****
* FRAME RELAY LOGICAL SUBAREA LINES FOR B75F48
*****
B75FRGL1 GROUP FRELAY=LOGICAL, X
                ISTATUS=ACTIVE, VTAM-only keyword X
                MAXOUT=127, X
                PHYSRSC=B75P48, Associate logical line with physical X
                RETRIES=(5,5,5), X
                SDLCST=(S75PRI,S75SEC)
*
*****
* LOGICAL LINE 1 --- DLCI X'60' TALKS TO DLCI X'50'
*****
B75LL1A LINE ISTATUS=ACTIVE, VTAM-only keyword *
                MONLINK=YES, *
                IPL=YES
*
B75PL1A PU DLCI=(60,H) FRTE support for DLCI '60' *
                ANS=CONTINUE, CONT is default for FRELAY=LOGICAL *
                PUTYPE=4, *
                TGN=1 Transmission group number is 1
    
```

Figure 16-37 (Part 2 of 2). Example: Frame-Relay Network with FHSPs and TESP (NCP2)

### Frame-Relay Network with 3746 Model 900

Figure 16-38 shows a frame-relay network containing four communication controllers. NCP2 provides frame-relay support for both its FHSPs and its TESP.

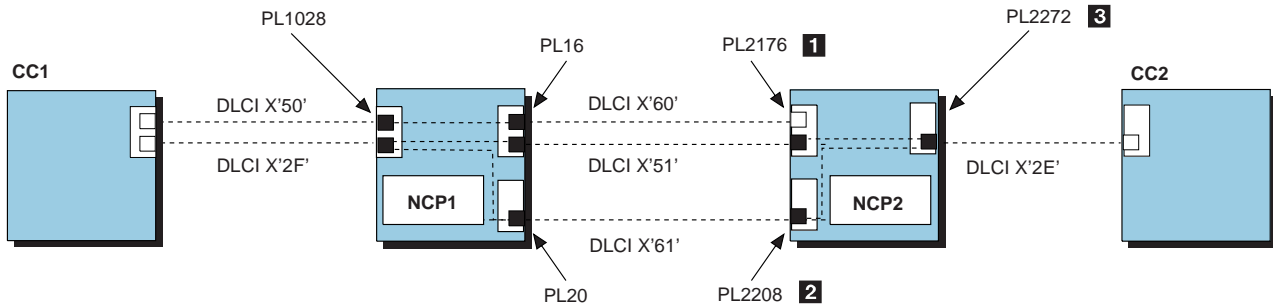

Figure 16-38. Frame-Relay Network with 3746 Model 900 FHSPs and TESP in NCP2

## Sample Frame-Relay Definitions

Figure 16-39 on page 16-87 shows how to code NCP2 in this example with 3746 Model 900 frame-relay support. The changes necessary to convert NCP2 in Figure 16-37 on page 16-84 from a 3745 frame-relay network to a 3746 Model 900 frame-relay network are the following:

- 1** The line address for DLCI X'51' must be within the range of 2112 to 2750. This example uses 2176. (The line address for DLCI X'51' in Figure 16-37 on page 16-84 was 48; this was within the acceptable range for a TSS adapter (0–895).)
- 2** The line address for DLCI X'61' must be within the range of 2112 to 2750. This example uses 2208. The line address for DLCI X'61' in Figure 16-37 on page 16-84 was 52; this is within the acceptable range for a TSS adapter (0–895).
- 3** The line address for DLCI X'2E' must be within the range of 2112 to 2750. This example uses 2272. (The line address for DLCI X'2E' in Figure 16-37 on page 16-84 was 1036; this was within the acceptable range for an HPTSS adapter (1024–1039).)
- 4** The PORTADD keyword is required for 3746 Model 900 frame relay.

**Note:** 3746 Model 900 frame-relay lines must not be coded under the same GROUP definition statement as 3745 frame-relay lines.

```

*****
*****                               N C P 2                               *****
*****
B75FRGP1 GROUP FRELAY=PHYSICAL,                                         X
                ISTATUS=ACTIVE,      VTAM-only keyword                 X
                TYPE=NCP,             Automatically added by NDF       X
                XMONLNK=YES

*
*****
* FRAME RELAY PHYSICAL LINE 2176 - FULL DUPLEX CSS                        *
*****
B75F2176 LINE ADDRESS=(2176,FULL), 1 *
                CLOCKNG=EXT, *
                MAXFRAME=2106, *
                NRZI=NO,         The default is NO *
                PORTADD=96,      PORTADD is required for CSS 4 *
                SPEED=56000
B75P2176 PU ERRORRT=(3,4), *
                LMI=ANSI, *
                SPOLL=6, *
                TIMERS=(10,15)

*
B75P76B PU DLCI=(51,H) FHSP for DLCI X'51'
*
*****
* FRAME RELAY PHYSICAL LINE 2208 - FULL DUPLEX CSS                        *
*****
B75F2208 LINE ADDRESS=(2208,FULL), 2 *
                CLOCKNG=EXT, *
                MAXFRAME=2106, *
                NRZI=NO,         The default is NO *
                PORTADD=97,      PORTADD is required for CSS 4 *
                SPEED=56000
B75P2208 PU ERRORRT=(3,4), *
                LMI=CCITT,      LMI subport *
                SPOLL=6, *
                TIMERS=(10,15)

*
B75P08B PU DLCI=(61,H) FHSP for DLCI X'61'
*
*****
* FRAME RELAY PHYSICAL LINE 2272 - FULL DUPLEX CSS                        *
*****
B75F2272 LINE ADDRESS=(2272,FULL), 3 *
                CLOCKNG=EXT, *
                MAXFRAME=2106, *
                NRZI=NO,         The default is NO *
                PORTADD=46,      PORTADD is required for CSS 4 *
                SPEED=1544000
B75P2272 PU ERRORRT=(3,4), *
                LMI=CCITT,      LMI subport *
                SPOLL=6, *
                TIMERS=(10,15)

*
B75P72B PU DLCI=(2E,H) FHSP for DLCI X'2E'
*

```

Figure 16-39 (Part 1 of 2). Example: Frame-Relay Network with 3746 Model 900 FHSPs and TESP in NCP2

## Sample Frame-Relay Definitions

```

*****
* FRSESET DEFINITIONS *
*****
PVCSET2 FRSESET SUBPORTS=(B75P72B,B75P76B,,B75P08B) X'2E'->X'51', X'61'
*
*****
* FRAME RELAY LOGICAL SUBAREA LINES FOR B75F2176 *
*****
B75FRGL1 GROUP FRELAY=LOGICAL, X
          ISTATUS=ACTIVE,      VTAM-only keyword X
          MAXOUT=127,          X
          PHYSRSC=B75F2176,    Associate logical line with physicalX
          RETRIES=(5,5,5),     X
          SDLCST=(S75PRI,S75SEC)

*
*****
* LOGICAL LINE 1 --- DLCI X'60' TALKS TO DLCI X'50' *
*****
B75LL1A LINE ISTATUS=ACTIVE,      VTAM-only keyword *
          MONLINK=YES,           *
          IPL=YES

*
B75PL1A PU  DLCI=(60,H),          FRTE subport for DLCI X'60' *
          ANS=CONTINUE,          CONT is default for FRELAY=LOGICAL *
          PUTYPE=4,              PUTYPE=4 added to GROUP by NDF *
          TGN=1                  Transmission group number is 1

```

Figure 16-39 (Part 2 of 2). Example: Frame-Relay Network with 3746 Model 900 FHSPs and TESP in NCP2



## Frame-Relay Network with Internal PVC Segment between 3746 Model 900 and NCP on a 3745

Figure 16-40 shows a frame-relay network containing four communication controllers. NCP1 and NCP2 have 3746 Model 900 frame-relay support and have internal PVC segments that enable internal frame switching between the NCP and 3746 Model 900.

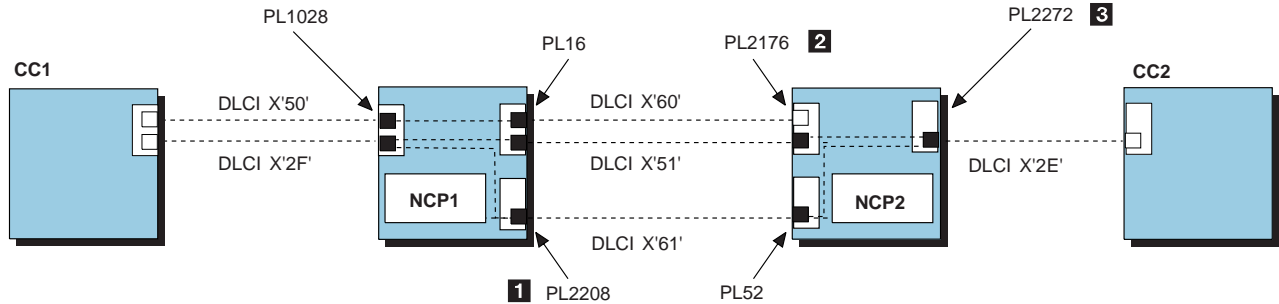

Figure 16-40. Frame-Relay Network with Internal PVC Segment between 3746 Model 900 and NCP on a 3745

Figure 16-41 on page 16-90 shows how to code NCP1 in this example to define an internal PVC segment between a 3745 FHSP and a 3746 Model 900 FHSP. To convert NCP1 in Figure 16-36 on page 16-82 to allow internal frame switching between it and a 3746 Model 900, make the following changes:

- 1** Redefine the line address for DLCI X'61' to be within the range 2112 to 2750. This example uses 2208. (The line address for DLCI X'61' in Figure 16-36 on page 16-82 was 20; this was within the acceptable range for a TSS adapter [0 to 895].)

**A** Define the PORTADD keyword which is required for 3746 Model 900 frame-relay.

**Note:** 3746 Model 900 frame-relay lines must not be coded under the same GROUP definition statement as 3745 frame-relay lines.

Figure 16-42 on page 16-91 shows how to code NCP2 in this example to define an internal PVC segment between a 3745 FHSP and a 3746 Model 900 FHSP. To convert NCP2 in Figure 16-37 on page 16-84 to enable internal frame switching between it and a 3746 Model 900, make the following changes:

- 2** Redefine the line address for DLCI X'51' to be within the range 2112 to 2750. This example uses 2176. (The line address for DLCI X'51' in Figure 16-37 on page 16-84 was 48; this was within the acceptable range for a TSS adapter [0 to 895].)

- 3** Redefine the line address for DLCI X'2E' to be within the range 2112 to 2750. This example uses 2272. (The line address for DLCI X'2E' in Figure 16-37 on page 16-84 was 1036; this was within the acceptable range for a HPTSS adapter [1024 to 1039].)

**B** Define the PORTADD keyword is required for 3746 Model 900 frame-relay.

**Note:** 3746 Model 900 frame-relay lines must not be coded under the same GROUP definition statement as 3745 frame-relay lines.

## Sample Frame-Relay Definitions

```

*****
*****                               N C P 1                               *****
*****
C04FRGP1 GROUP FRELAY=PHYSICAL,                                         X
                ISTATUS=ACTIVE,      VTAM-only keyword                 X
                TYPE=NCP              Automatically added by NDF
*
*****
* FRAME RELAY PHYSICAL LINE 16 - FULL DUPLEX 56 KB                       *
*****
C04F16  LINE  ADDRESS=(016,FULL),                                         *
                MAXFRAME=2106,                                           *
                CLOCKNG=EXT,                                             *
                NRZI=NO,          The default is NO                       *
                SPEED=56000
C04P16  PU    LMI=ANSI,                                                  *
                SPOLL=6,                                                 *
                ERRORT=(3,4),                                           *
                TIMERS=(10,15)
*
C04P16B PU    DLCI=(51,H)          FHSP for DLCI X'51'
*
C04P16C PU    DLCI=(60,H)          FHSP for DLCI X'60'
*
*****
* FRAME RELAY PHYSICAL LINE 2208 - FULL DUPLEX CSS                       *
*****
C04F2208 LINE ADDRESS=(2208,FULL), 1                                     *
                MAXFRAME=2106,                                           *
                CLOCKNG=EXT,                                             *
                NRZI=NO,          The default is NO                       *
                PORTADD=97        PORTADD is required for CSS A       *
                SPEED=56000
C04P2208 PU    ERRORT=(3,4),                                           *
                LMI=CCITT,        LMI subport                            *
                SPOLL=6,                                                 *
                TIMERS=(10,15)
*
C04P08B PU    DLCI=(61,H)          FHSP for DLCI X'61'
*

```

Figure 16-41 (Part 1 of 2). Example: Frame-Relay Network with Internal PVC Segment between 3745 and 3746 Model 900 (NCP1)

```

*****
* FRAME RELAY PHYSICAL LINE 1028 - FULL DUPLEX HPTSS *
*****
C04F1028 LINE ADDRESS=(1028,FULL), *
                MAXFRAME=2106, *
                CLOCKNG=EXT, *
                NRZI=NO, The default is NO *
                SPEED=1544000
C04P1028 PU LMI=CCITT, LMI subport *
                SPOLL=6, *
                ERRORT=(3,4), *
                TIMERS=(10,15)
*
C04P28B PU DLCI=(2F,H) FHSP for DLCI X'2F'
*
C04P28C PU DLCI=(50,H) FHSP for DLCI X'50'
*
*****
* FRSESET DEFINITIONS *
*****
PVCSET2 FRSESET SUBPORTS=(C04P28B,C04P16B,,C04P08B) X'2F'->X'51',X'61'
PVCSET3 FRSESET SUBPORTS=(C04P28C,C04P16C) DLCI X'50'->X'60'

```

Figure 16-41 (Part 2 of 2). Example: Frame-Relay Network with Internal PVC Segment between 3745 and 3746 Model 900 (NCP1)

```

*****
***** N C P 2 *****
*****
B75FRGP1 GROUP FRELAY=PHYSICAL, X
                ISTATUS=ACTIVE, VTAM-only keyword X
                TYPE=NCP, Automatically added by NDF X
                XMONLNK=YES
*
*****
* FRAME RELAY PHYSICAL LINE 2176 - FULL DUPLEX CSS *
*****
B75F2176 LINE ADDRESS=(2176,FULL), 2 *
                CLOCKNG=EXT, *
                MAXFRAME=2106, *
                NRZI=NO, The default is NO *
                PORTADD=96, PORTADD is required for CSS B *
                SPEED=56000
B75P2176 PU ERRORT=(3,4), *
                LMI=ANSI, *
                SPOLL=6, *
                TIMERS=(10,15)
*
B75P76B PU DLCI=(51,H) FHSP for DLCI X'51'
*

```

Figure 16-42 (Part 1 of 3). Example: Frame-Relay Network with Internal PVC Segment between 3745 and 3746 Model 900 (NCP2)

## Sample Frame-Relay Definitions

```

*****
* FRAME RELAY PHYSICAL LINE 52 - FULL DUPLEX 56KB
*****
B75F52  LINE  ADDRESS=(052,FULL),
          CLOCKNG=EXT,
          MAXFRAME=2106,
          NRZI=NO,           The default is NO
          SPEED=56000
B75P52  PU    ERRORR=(3,4),
          LMI=CCITT,        LMI subport
          SPOLL=6,
          TIMERS=(10,15)

*
B75P52B PU    DLCI=(61,H)      FHSP for DLCI X'61'
*
*****
* FRAME RELAY PHYSICAL LINE 2272 - FULL DUPLEX CSS
*****
B75F2272 LINE ADDRESS=(2272,FULL), 3
          CLOCKNG=EXT,
          MAXFRAME=2106,
          NRZI=NO,           The default is NO
          PORTADD=46,        PORTADD is required for CSS B
          SPEED=1544000
B75P1036 PU  ERRORR=(3,4),
          LMI=CCITT,        LMI subport
          SPOLL=6,
          TIMERS=(10,15)

*
B75P36B PU    DLCI=(2E,H)      FHSP for DLCI X'2E'
*
*****
* FRSESET DEFINITIONS
*****
PVCSET2 FRSESET SUBPORTS=(B75P36B,B75P76B,,B75P52B) X'2E'->X'51',X'61'
*
*****
* FRAME RELAY LOGICAL SUBAREA LINES FOR B75F2176
*****
B75FRGL1 GROUP FRELAY=LOGICAL,
              ISTATUS=ACTIVE,   VTAM-only keyword
              MAXOUT=127,
              PHYSRSC=B75F2176, Associate logical line with physical
              RETRIES=(5,5,5),
              SDLCST=(S75PRI,S75SEC)

```

Figure 16-42 (Part 2 of 3). Example: Frame-Relay Network with Internal PVC Segment between 3745 and 3746 Model 900 (NCP2)

```

*
*****
* LOGICAL LINE 1 --- DLCI X'60' TALKS TO DLCI X'50' *
*****
B75LL1A LINE ISTATUS=ACTIVE,      VTAM-only keyword *
          MONLINK=YES,           *
          IPL=YES
*
B75PL1A PU  DLCI=(60,H)           FRTE support for DLCI X'60' *
          ANS=CONTINUE,          CONT is default for FRELAY=LOGICAL *
          PUTYPE=4,              *
          TGN=1                  Transmission group number is 1 *
    
```

Figure 16-42 (Part 3 of 3). Example: Frame-Relay Network with Internal PVC Segment between 3745 and 3746 Model 900 (NCP2)

### Switched Frame-Relay Physical Line

Figure 16-43 shows a switched frame-relay physical line acting as a backup connection between an IBM 2210 Router and an IBM 3745 Communication Controller.

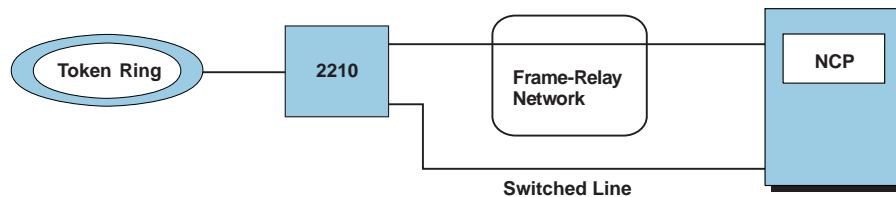

Figure 16-43. Switched Frame-Relay Physical Line

Figure 16-44 shows a sample generation definition for this configuration. In this sample, the switched frame-relay physical line is attached to a 3745.

```

*****
* NCP3 - PHYSICAL LEASED LINE GROUP *
*****
PGRP3  GROUP  FRELAY=(PHYSICAL,PER) Physical peripheral line
*
PHYLPA3 LINE  ADDRESS=(032,FULL), TSS adapter address is 32 *
          MAXFRAME=2106,         Maximum frame size *
          NRZI=YES,              NRZI mode. The default is NO *
          PORTADD=32,            Port number is 32 *
          SPEED=9600,            Line speed *
          DATABLK=4096
*
PHYPPA3 PU   ANS=CONT,           ANS=CONT added to PU by NDF *
          LMI=ANSI               LMI support PU *
          .
          .
          .
    
```

Figure 16-44. Example: 3745 Switched Frame-Relay Physical Line

## Sample Frame-Relay Definitions

```

*****
* NCP3 - PHYSICAL SWITCHED LINE GROUP *
*****
SPGRP3 GROUP FRELAY=(PHYSICAL,PER), Dial physical peripheral line *
        DIAL=YES
*
SPHYLPA3 LINE ADDRESS=(016,FULL), TSS adapter address is 16 *
              MAXFRAME=2106,      Maximum frame size *
              NRZI=YES,           NRZI mode. The default is NO *
              PORTADD=33,         Port number is 33 *
              SPEED=9600,        Line speed *
              ID=00456789,       Node ID *
              V25BIS=(YES,DLSDLC), V.25Bis *
              DATABLK=4096
*
SPHYPPA3 PU LMI=ANSI LMI subport PU
*****
* NCP3 - LOGICAL LINE GROUP *
*****
LGRP GROUP FRELAY=(LOGICAL,PER), Logical peripheral line *
        AUTOGEN=10, Add 10 LINE/PU pairs *
        CALL=INOUT, VTAM-only keyword *
        LOCALTO=20 Reply timer value

```

Figure 16-44. Example: 3745 Switched Frame-Relay Physical Line

Figure 16-45 shows another sample generation definition for the configuration shown in Figure 16-43 on page 16-93. In this sample, the switched frame-relay physical line is attached to a 3746 Model 900.

```

*****
* FRAME RELAY Switched PHYSICAL LINE 2244 (3746 Model 900) *
*****
A80FRPG1 GROUP FRELAY=(PHYSICAL,ANY),DIAL=YES, ISTATUS=ACTIVE,TYPE=NCP, *
              MAXFRAME=4096, LNCTL=SDLC,PUTYPE=1
A80F2244 LINE ADDRESS=(2244,FULL),MAXDLCI=600,DATABLK=265, *
              AUTO=YES,ID=08002244,V25BIS=(YES,DLSDLC),CALL=INOUT, *
              PORTADD=40,CLOCKNG=EXT,NRZI=NO,SPEED=9600
A80LMI44 PU LMI=CCITT,INNPORT=YES,ANS=CONT
*****
* FRAME RELAY LOGICAL INN LINES FOR A80F2240 *
*****
A80FRLG1 GROUP FRELAY=(LOGICAL,SUB), ISTATUS=ACTIVE,MAXOUT=127, *
              SDLCST=(A80PRI,A80SEC),MODULO=128,LOCALTO=5, *
              T2TIMER=(.5,,64),RETRIES=(2,2,2),TYPE=NCP,DIAL=NO, *
              PHYSRSC=A80LMI44, *
              LNCTL=SDLC,PUTYPE=4

```

Figure 16-45. Example: 3746 Model 900 Switched Frame-Relay Physical Line

```

A80LLB0 LINE ISTATUS=ACTIVE,MLTGPRI=40
A80PLB0 PU PUTYPE=4,BLOCK=(4096,5),TGCONF=(MULTI,NORMAL), *
        ADDR=10,ANS=CONTINUE,TGN=1
A80LLB1 LINE ISTATUS=ACTIVE,MLTGPRI=30
A80PLB1 PU PUTYPE=4,BLOCK=(4096,5),TGCONF=(MULTI,STANDBY,3), *
        ADDR=11,ANS=CONTINUE,TGN=1
A80LLB2 LINE ISTATUS=ACTIVE,MLTGPRI=20
A80PLB2 PU PUTYPE=4,BLOCK=(4096,5),ADDR=12,TGN=1
A80LLB3 LINE ISTATUS=ACTIVE,MLTGPRI=10
A80PLB3 PU PUTYPE=4,BLOCK=(4096,5),ADDR=13,ANS=CONT,TGN=1
*****
* FRAME RELAY LOGICAL BNN LINES - PHYRSC=(NONE,ODLC) *
*****
A80FRLGB GROUP FRELAY=(LOGICAL,PER), *
        ANS=CONTINUE, *
        AUTOGEN=5, *
        CALL=INOUT, *
        MODETAB=AMODETAB, *
        ISTATUS=ACTIVE, *
        LOCALTO=10, *
        PHYRSC=A80LMI44, *
        USSTAB=AMODETAB, *
        RETRIES=(10,10,10), *
        TYPE=NCP, *
        DIAL=YES, *
        LNCTL=SDLC, *
        LINEAUT=YES, *
        NPACOLL=(YES,EXTENDED), *
        PUTYPE=2

```

Figure 16-45. Example: 3746 Model 900 Switched Frame-Relay Physical Line





---

## Part 3. Defining Pre-SNA NCP Resources

<b>Chapter 17. Multiple Terminal Access Terminals</b> . . . . .	17-1
Multiple Terminal Access Sign-on Procedures . . . . .	17-1
Overview of Procedures . . . . .	17-1
Errors in the Sign-on Procedure . . . . .	17-2
Defining MTA Tables . . . . .	17-3
MTA Device Characteristics . . . . .	17-5
Terminal Type . . . . .	17-6
Polling Character . . . . .	17-7
Defining an MTA Table . . . . .	17-7
<b>Chapter 18. Teletypewriter Exchange Service</b> . . . . .	18-1
Defining TWX Terminal Characteristics . . . . .	18-1
TWX Terminals Attached to a Switched Telecommunication Link . . . . .	18-2
TWX Terminals Attached to MTA Lines . . . . .	18-4
<b>Chapter 19. World Trade Teletypewriter Terminals</b> . . . . .	19-1
Character Transmission . . . . .	19-1



---

## Chapter 17. Multiple Terminal Access Terminals

Use this chapter only if you define start-stop devices.

The multiple-terminal-access (MTA) facility is a feature of NCP that permits it to communicate with a variety of dissimilar start-stop devices over the same switched network connection, or port. These devices are:

- IBM 1050 Data Communication System terminals
- IBM 2740 Communication Terminals (basic)
- IBM 2740 Communication Terminals (with record checking)
- IBM 2740 Communication Terminals (with transmit control)
- IBM 2740 Communication Terminals (with transmit control and record checking)
- IBM 2741 Communication Terminals
- IBM 3767 Communication Terminals (supported as IBM 2741 Communication Terminals)
- Teletypewriter exchange service (TWX) terminals.

**Note:** In an MTA environment, the IBM 2741 and the IBM 3767 (in 2741 mode) are mutually exclusive.

Terminals under MTA facility control require a sign-on procedure that enables NCP to determine the type of terminal calling the controller. NCP analyzes the sign-on message and control characters, then selects the appropriate control procedures for use with that terminal. It uses the selected procedure for as long as the connection to that terminal exists.

---

### Multiple Terminal Access Sign-on Procedures

The sign-on procedures for MTA terminals differ for various types of terminals.

#### Overview of Procedures

A general procedure for signing on to MTA terminals is as follows:

##### **For All Types of MTA Terminals Except TWX:**

1. Dial the telephone number of the MTA link used to communicate with the controller.
2. The keyboard will unlock and the proceed light will come on (for 1050) or the bid message will print (for basic 2740 and 2740 with checking). Enter the 2 characters /" (slash double-quotation mark). Permit the bid message to be completely printed before pressing the bid key and entering the /" characters. Failure to do so can cause unpredictable results. The bid message is transmitted in both correspondence code and in EBCD/BCD code so that it is printed intelligibly regardless of the code used.
3. If you define more than one line control selection table (LCST) entry in the MTATABLE definition statement representing the terminal, enter a 2-digit index number representing the LCST entry used by the program when communicating with the terminal. (See "Defining MTA Tables" on page 17-3 for an

## Multiple Terminal Access Sign-on Procedures

explanation of the MTALCST and MTATABL definition statements.) The first entry named in the MTATABL definition statement associated with the terminal is represented by index number 00, the second by 11, and so on. The two digits must be identical. If the first entry is used, or only one entry is named in the MTATABL definition statement, you do not need to enter the 00 index number. NCP uses the first (or only) entry if no index number is entered.

4. End the sign-on procedure as follows:

*For IBM 1050, IBM 2740 with checking, or IBM 2740 with transmit control and record checking:*

Press the return key, then enter the end-of-block (EOB) character. If you enter end-of-transmission (EOT) rather than EOB from a 1050, NCP breaks the line connection; the controller must be redialed and the sign-on procedure repeated.

*For basic IBM 2740 or IBM 2740 with transmit control:*

Press the return key, then enter the EOT character.

*For IBM 2741:*

Press the return key.

### **For TWX Terminals:**

1. Dial the telephone number of the MTA link used to communicate with the controller.
2. Press the WRU key within 3 seconds after the audible data tone begins. (If you wait longer than 3 seconds, a timeout occurs and the connection breaks.)

These two steps are the entire sign-on procedure. Multiple line control selection table (LCST) entries cannot be defined for TWX terminals, so there is no index number to enter.

## Errors in the Sign-on Procedure

If the typing mechanism of the terminal does not move after you enter the sign-on message, assume that the sign-on was successful and begin keying message data.

However, if you make an error entering the sign-on message, or NCP cannot identify the type of terminal, the program sends a character sequence that “wiggles” the typing mechanism to signal you to reenter the sign-on message. (If the terminal is a basic IBM 2740, press the bid key before reentering the message.)

If you delay too long in completing the sign-on message, or you enter it erroneously enough times to reach the retry limit, NCP breaks the line connection. Redial the controller and begin again. MTARTO on the BUILD definition statement limits the amount of time to complete the sign-on message; MTARTRY on BUILD limits the number of retries.

## Defining MTA Tables

After a call is established on an MTA line and NCP has identified the terminal type, the terminal operator selects a unique combination of terminal operating characteristics from the MTA table. The table is composed of the names of one to 10 MTALCST definition statements, each of which specifies a unique combination of terminal operating characteristics. However, the table contains only names of MTALCST definition statements with the same line control and code combination as coded on the MTATABL definition statement.

For IBM terminals, the repeated character the terminal operator enters during terminal sign-on determines selection of the appropriate combination of terminal operating characteristics. For TWX terminals, selection is based upon the results of applying mask and compare characters to the first character entered by the TWX terminal operator. Mask and compare characters are those specified for MTALCST definition statements named by the LCST keyword. Their order of use is determined by the order in which the MTALCST definition statements are named.

Code only one MTATABL definition statement for a given combination of line control type and transmission code. In one MTATABL definition statement, specify the names of up to 10 MTALCST definition statements.

Code the following definition statements and keywords to provide NCP with information about the MTA selection table and the MTALCST definition statements that create entries in the table.

MTALCST	CODE LCTYPE LINESIZ
MTATABL	CODE LCST LCTYPE

CODE on the MTALCST definition statement identifies the type of transmission code NCP uses to communicate with the MTA terminal. NCP translates outgoing data characters from the internal processing code, EBCDIC, to the code you specify in this keyword, and translates incoming characters from the code you specify into EBCDIC. The transmission code used on a multipoint telecommunication link must be the same for all devices attached to that link. NCP uses internal translation tables to convert one code to another. The contents of the translation tables are defined in *NCP and EP Reference Summary and Data Areas, Volume 2*.

LCTYPE specifies the type of terminal and line control to be used. See *NCP, SSP, and EP Resource Definition Reference* for the correct value to be coded for different device and line control configurations.

LINESIZ defines the length of the print line for any printers attached to the MTA line.

## Defining MTA Tables

CODE on the MTATABL definition statement identifies the type of transmission code NCP uses to communicate with the MTA terminal.

LCST specifies the names of up to 10 MTALCST definition statements that define entries in the MTA selection table.

LCTYPE specifies the type of terminal and line control to be used.

### Sample Code to Define MTA Table Entries

Figure 17-1 shows how to code a single MTALCST definition statement that defines a 2741 using BCD code.

```
MTA1    MTALCST  LCTYPE=2741,  
                CODE=BCD,...
```

Figure 17-1. Example: Defining MTALCST for a 2741 Using BCD Code

Figure 17-2 shows how to define an MTATABL definition statement that specifies the same line control and code.

```
MTATABL LCST=(MTA1),  
                LCTYPE=2741,  
                CODE=BCD
```

Figure 17-2. Example: Defining MTATABL for a 2741 Using BCD Code

If you code two MTALCST definition statements which both define a 2741 using BCD code but with a different set of operating parameters, code an MTATABL definition statement that specifies the same line control and transmission code and names both MTALCST definition statements. Figure 17-3 shows how to code these definition statements.

Code only one MTATABL definition statement for a given combination of line control type and transmission code. One MTATABL definition statement can identify as many as 10 MTALCST definition statements.

```
MTA1    MTALCST  LCTYPE=2741,  
                CODE=BCD,  
                LINESIZ=72, ...  
*  
MTA2    MTALCST  LCTYPE=2741,  
                CODE=BCD,  
                LINESIZ=90, ...  
*  
                MTATABL LCST=(MTA1,MTA2),  
                LCTYPE=2741,  
                CODE=BCD
```

Figure 17-3. Example: Defining Two MTALCST Statements

## MTA Device Characteristics

The MTALCST definition statement defines entries in a line control selection table generated for the MTA links connected to NCP. Each entry represents a particular combination of device characteristics defining an MTA terminal that can call NCP on an MTA link. Code one MTALCST definition statement for each distinct combination of parameters you need to define the MTA terminals. Define MTA terminals using individual TERMINAL definition statements.

Code the following definition statements and keywords to provide NCP with information about MTA device characteristics and the operational features of the device.

MTALCST	ACR CLOCKNG CODE CRRATE DATRATE GROUP LCTYPE LINESIZ RETRIES SPEED TRANSFR
TERMINAL	LCST

### MTALCST

ACR on the MTALCST definition statement specifies whether the IBM 1050 Data Communication System terminals that call NCP on the link associated with this entry are equipped with the accelerated carriage return feature.

CLOCKNG determines whether the modem or the communication scanner for the MTA link associated with the entry provides clocking. A modem provides external clocking. A scanner provides internal clocking, also known as business machine clocking.

CODE identifies the type of transmission code NCP uses to communicate with the terminal associated with the entry. NCP translates outgoing data characters from the internal processing code, EBCDIC, to the code you specify in this keyword, and translates incoming characters from the code you specify into EBCDIC. The transmission code used on a multipoint telecommunication link must be the same for all devices attached to that link. Associated with each transmission code is a translation table contained within NCP. The contents of the translation tables are defined in *NCP and EP Reference Summary and Data Areas, Volume 2*.

CRRATE specifies the number of print positions the carriage returns for each idle character NCP sends to any printers attached to the MTA link associated with the entry.

DATRATE specifies whether the link connected to this modem operates at a high rate or a low rate, when NCP can control the rate. DATRATE is used if the modem

## Terminal Type

that attaches the MTA telecommunication link associated with the entry to the communication controller is a dual-rate modem.

GROUP names the stand-alone GROUP definition statement defining device characteristics that are the same as the characteristics of the MTA terminal associated with the entry.

LCTYPE specifies the type of terminal that uses the entry. In MTA operation, a terminal type refers not to a particular numeric designation, such as IBM 1050 Data Communication System device or IBM 2741 Communication Terminal, but to a unique combination of the line control and transmission code used by the terminal. For example, an IBM 1050 Data Communication System device using BCD code and an IBM 1050 Data Communication System device using EBCD code represent two different types of terminals, even though they are both IBM 1050 Data Communication System devices.

LINESIZ defines the length of the print line for any printers attached to the MTA link associated with the entry.

RETRIES specifies the number of attempts NCP is to make to recover from errors in message data sent to or received from an IBM 1050 Data Communication System terminal or IBM 2740 Communication Terminal (with record checking) MTA terminal.

SPEED defines the data rate of the MTA telecommunication link associated with the entry.

TRANSFR limits the number of buffers NCP obtains to receive message text from the MTA terminal associated with the entry before transferring the contents of filled buffers to the access method. If NCP receives the specified number of buffers, it transfers their contents to the access method as a subblock but continues to receive message text from the terminal until it receives an end-of-block or end-of-transmission character.

## TERMINAL

LCST specifies the name of the MTALCST definition statement that defines the set of device characteristics NCP uses when it calls the MTA terminal.

---

## Terminal Type

Code the following definition statements and keywords to provide NCP with information about the type of terminal to be defined.

MTALIST	LCTYPE
LINE	MTALIST

LCTYPE on the MTALIST definition statement specifies the type of terminals that can call a particular MTA telecommunication link. The MTALIST definition statement must immediately follow the MTALCST definition statement or statements defining the terminal types.



MTALIST on the LINE definition statement specifies the name of the MTALIST definition statement that defines the list identifying the types of terminals that can call NCP over the MTA link.

---

## Polling Character

Code the following definition statement and keyword to provide NCP with information about polling characters used by MTA terminals.

MTAPOLL	POLL
---------	------

POLL on the MTAPOLL definition statement specifies the list of polling characters used by IBM 1050 Data Communication System MTA terminals that can call the controller over any call-in MTA link.

---

## Defining an MTA Table

Define an MTATABL definition statement for each unique combination of line control and transmission code that you define in an MTALCST definition statement. Code the following definition statement and keywords to provide NCP with information about an MTATABL entry.

MTATABL	LCST
	CODE
	LCTYPE

LCST on the MTATABL definition statement specifies the names of up to 10 MTALCST definition statements that define the same line control and transmission code as the MTATABL definition statement.

CODE identifies the transmission code used by the type of MTA terminal for which you code this definition statement.

LCTYPE specifies the line control used by the type of MTA terminal you code on this definition statement.



---

## Chapter 18. Teletypewriter Exchange Service

This chapter describes the definition statements and keywords for defining teletypewriter exchange service (TWX) terminals to NCP. Use this chapter only if you are defining start-stop devices.

---

### Defining TWX Terminal Characteristics

Code the following definition statements and keywords to provide NCP with information about operational characteristics associated with TWX terminals such as character transmission, a prompting sequence, parity, and the keyboard lock function.

GROUP	CHAREC FRAMING KBDLOCK PECHAR
LINE	MONITOR PARCHK PARGEN
TERMINAL	XTWXID

#### GROUP

CHAREC on the GROUP definition statement defines the message-ending characters NCP recognizes when it receives data from the TWX terminals attached to the telecommunication links in the group. NCP does not recognize any characters other than WRU, XON, XOFF, or EOT unless you specify them for CHAREC.

FRAMING specifies the number of stop bits per character NCP sends and expects to receive from the TWX terminals attached to the links in the group.

KBDLOCK defines the hexadecimal representation of the nonprinting, nonspace character NCP sends to the TWX terminals attached to the links in the group to signal the operator to stop using the keyboard. A TWX terminal is not polled or addressed and has no control of contention for send and receive. Because the terminal keyboard is not usually locked before transmission to the terminal, it is possible for an operator to enter data while NCP sends data to the terminal. This entered data is lost because NCP cannot receive data while it is transmitting. By using KBDLOCK, you can prevent an operator from entering data before NCP is ready to receive. If you want to include the KBDLOCK function for the TWX terminals in the group, also code MONITOR on the LINE definition statement.

PECHAR defines the hexadecimal representation of the data character NCP uses to overlay a character with incorrect parity received from the TWX terminals attached to the telecommunication links in the group.

#### LINE

## TWX Terminals on Switched Telecommunication Links

MONITOR on the LINE definition statement specifies that NCP monitors the telecommunication link to which a particular TWX terminal is attached for an attention signal or disconnect condition.

**Note:** NCP also provides an internal safeguard against loss of data due to an unlocked keyboard by automatically executing a READ command when no other command is executing and the line is not in monitor mode (MONITOR=NO).

PARCHK specifies whether NCP checks for odd, even, mark, or space parity, or does not set parity for the TWX terminals attached to the link.

PARGEN specifies whether NCP generates even, odd, mark, or space parity, or does not set parity for data transmitted on the link.

## TERMINAL

XTWXID on the TERMINAL definition statement specifies whether NCP, at line activation time, transmits the TWX identification or PROMPT for the link. Code XTWXID=NO for nonswitched telecommunication links.

### Sample Definition of TWX Operational Characteristics

Figure 18-1 shows how to code various operational features associated with TWX terminals.

```
GSSNTOR GROUP .
      .
      CHAREC=(XOFF,8D),  Message ending characters
      .
      .
LTWX06R LINE .
      .
      MONITOR=YES,      Monitor for attention signal/disconn
      .
      .
TWX06D  TERMINAL
      .
      .
```

Figure 18-1. Example: Defining TWX Terminal Features

---

## TWX Terminals Attached to a Switched Telecommunication Link

Code the following definition statements and keywords to provide NCP with information about the connection between NCP and TWX terminals attached to switched links.

BUILD	TWXID
IDLIST	IDSEQ MAXLEN NOMATCH
LINE	PROMPT
TERMINAL	CUIDLEN IDSEQ

## BUILD

TWXID on the BUILD definition statement specifies the characters NCP uses as the answerback and prompting sequences sent to all TWX terminals whenever a switched connection is established between a terminal and NCP. Define two sets of characters: one to be used when the terminal initiates the connection, and the other when NCP initiates the connection. The last character you specify (presumably an X-on or WRU) is not transmitted during the initial identification answerback or subsequent prompting sequences sent as part of each TWX terminal read operation. Instead, NCP generates and sends an X-on character in place of the last character you code. Prompting is selected by the access method through set destination mode and is always bypassed if data is received in read-ahead mode. Specify the length of the answerback sequence sent on CUIDLEN on the TERMINAL definition statement for each TWX terminal. If you omit CUIDLEN, the program does not send the answerback sequence to the TWX terminal.

## IDLIST

IDSEQ on the IDLIST definition statement defines the identification sequence used by each TWX terminal that calls or is called by NCP. IDSEQ also specifies the name of the TERMINAL definition statement that defines the terminal associated with each identification sequence.

MAXLEN sets the maximum size of the list of identification sequences coded on the IDSEQ keyword. Define MAXLEN only if the access method uses the dynamic control facility to either add entries to the list or increase the size of one or more existing entries in the list. MAXLEN specifies the size of the list (in bytes), not the number of entries in the list. It includes the number of bytes in all entries, plus the control field that precedes the list.

NOMATCH specifies the action that NCP takes if it does not receive an identification sequence from a calling terminal or it receives an identification sequence not defined in this IDLIST definition statement. You can have NCP indicate in a response to the access method that no identification sequence was received and that NCP pass on any unrecognized identification sequences. Otherwise, specify that NCP break the link connection and not send any unrecognized identification sequences to the access method.

**Note:** Code IDSEQ, MAXLEN, and NOMATCH on the IDLIST definition statement only for TCAM.

## LINE

PROMPT on the LINE definition statement determines whether NCP, at READ time, provides the TWX identifier or PROMPT for the telecommunication link.

## TWX Terminals Attached to MTA Lines

**Note:** A TWXID sequence is referred to as an *identification* at line activation time and as a *PROMPT* at read time.

### TERMINAL

CUIDLEN on the TERMINAL definition statement specifies the length of the identification sequence that NCP sends to the TWX terminal when the terminal initiates the connection. Define this identification sequence for TWXID on the BUILD definition statement.

IDSEQ on the TERMINAL definition statement specifies whether the TWX terminal sends an identification sequence when it calls or is called by NCP and, if so, how NCP reacts to the sequence.

---

## TWX Terminals Attached to MTA Lines

Code the following definition statements and keywords to provide NCP with information about operational features for TWX terminals that communicate over MTA lines by using the MTA selection table entry.

MTALCST	COMPARE
	MASK

COMPARE on the MTALCST definition statement specifies the hexadecimal representation of the compare character that NCP uses to locate the line control selection table (LCST) entry for TWX terminals attached to MTA links. A logical AND operation applies the mask character coded on the MASK keyword with the first character NCP receives from a TWX terminal. If the result equals the compare character coded on the COMPARE keyword, the contents of the LCST entry you define with this MTALCST statement are used to establish the operating characteristics for the terminal.

MASK defines the hexadecimal representation of the mask character NCP uses during the LCST entry selection process for TWX terminals attached to MTA lines.

---

## Chapter 19. World Trade Teletypewriter Terminals

This chapter describes the definition statements and keywords for defining World Trade Teletypewriter (WTTY) terminals to NCP. Use this chapter only if you are defining start-stop devices.

---

### Character Transmission

Code the following definition statement and keywords to provide NCP with information about character transmission for WTTY terminals.

GROUP	PADCNT WTTYEOB WTTYEOT
-------	------------------------------

PADCNT on the GROUP definition statement specifies how many idle characters NCP sends to the WTTY terminals attached to the telecommunication links in the group. These idle characters give the terminal time for its motor to reach full speed before it receives data from NCP. You do not have to code PADCNT if all of the WTTY terminals are equipped with continuously running motors.

WTTYEOB identifies the hexadecimal end-of-block (EOB) sequence that marks the end of each transmitted segment of a message.

WTTYEOT identifies the hexadecimal end-of-transmission (EOT) sequence that marks the end of the entire transmitted message.





---

## Part 4. Defining Emulation Program Resources

<b>Chapter 20. BSC and Start-Stop Devices Operating in PEP Environment</b>	20-1
Emulation Subchannel	20-1
BSC Telecommunication Links in PEP Mode	20-3
WTTY Terminals in PEP Mode	20-4
Switched Telecommunication Links	20-4
Modems	20-4
Devices	20-5
Control Units	20-5
Data Transmission Characteristics	20-6
Character Transmission	20-7
Timeouts	20-7
Sample Definition of Emulation Mode Subchannels	20-8
<b>Chapter 21. Defining a Standalone EP Network</b>	21-1
How Resources Are Defined to EPSA	21-3
Defining Your System	21-3
Defining Your Network Configuration	21-4
Coding LINE Keywords on the GROUP Definition Statements	21-4
GROUP Definition Statement	21-6
LINE Definition Statement	21-6
Sequence of LINE and GROUP	21-7
Defining Your Generation Procedure	21-8
Defining the End of Your Generation	21-8
Defining Your System	21-8
Diagnostic Operations for the Generation Procedure	21-9
Verification of the Generation Definition	21-10
Communication Controller	21-11
Diagnostic Aids	21-13
EP Buffers	21-14
Defining Characteristics and Functions Common to BSC and SS Devices	21-14
Control Units	21-14
Line Characteristics	21-14
Switched Lines	21-15
Modem Characteristics	21-15
Modems for a Switched Line	21-16
Device Type	21-16
Defining Characteristics and Functions for BSC Devices	21-16
Line Priority	21-16
Device Features	21-17
Modems	21-17
Communication Controllers Connected by a BSC Line	21-17
Line Characteristics	21-17
Buffer Size	21-18
Data Characteristics	21-18
Defining Characteristics and Functions for SS Devices	21-19
Response Mode	21-19
Switched Lines	21-19
Device Features	21-20
Data Characteristics	21-20
Character Transmission	21-20

Timeouts . . . . . 21-21  
WTTY Terminals . . . . . 21-21  
Performance Characteristics . . . . . 21-21

---

## Chapter 20. BSC and Start-Stop Devices Operating in PEP Environment

This chapter tells you how to define EP for IBM 3745 Communication Controllers in a PEP environment.

Devices running in Partitioned Emulation Program (PEP) mode are those attached to telecommunication links defined to operate in EP mode only, or in either network control mode or EP mode. A link cannot operate in emulation mode unless you use EP to include emulation functions in NCP. For more information on defining a standalone EP network, please see Chapter 21, "Defining a Standalone EP Network" on page 21-1.

Figure 20-1 shows how an emulation mode device communicates with an emulation application in an IBM host processor over an emulation subchannel.

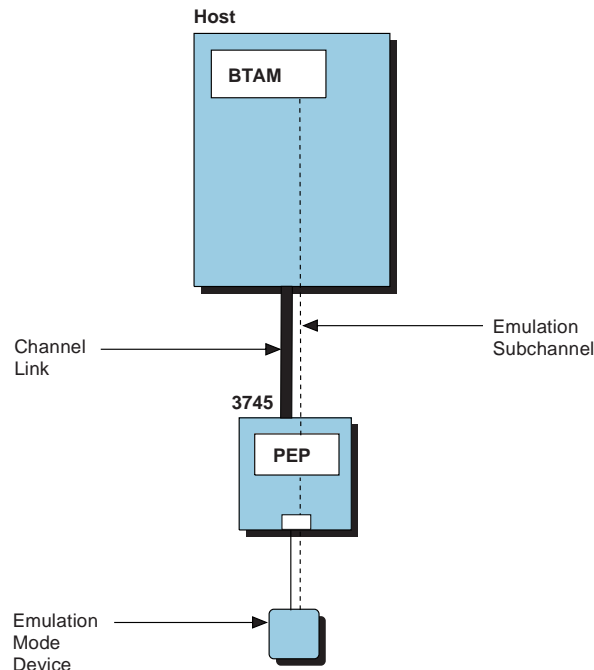

Figure 20-1. Emulation Mode Resources

This chapter describes the definition statements and keywords you need to define the relationship of NCP to emulation mode devices.

---

### Emulation Subchannel

An emulation subchannel is a division of a channel path used for emulation mode resources. Code the following definition statement and keywords to provide NCP with information about emulation subchannel addresses, improve performance, and report errors.

## Emulation Subchannel

LINE	ADDRESS
	CHNPRI
	DYNADMP
	HICHAN
	LOCHAN

ADDRESS on the LINE definition statement defines the emulation subchannel address for the line.

CHNPRI establishes the priority of the emulation subchannel associated with the link. A priority is either normal or high. Normal priority is appropriate unless the data rate of the link is 19200 bps or more and the majority of the remaining links are slow-speed links (2400 bps or less).

DYNADMP specifies the address of the emulation subchannel to be used to transfer dynamic dump data to the host processor.

To conserve storage, avoid unassigned subchannel addresses. Unassigned subchannels are those not identified by ADDRESS or DYNADMP on a LINE definition statement that defines the link to a peripheral emulation mode device. You can avoid unassigned subchannels by assigning sequential addresses to all emulation subchannels or limiting the range of HICHAN and LOCHAN to those subchannel addresses actually defined.

Unassigned subchannel addresses can cause the following to occur:

- NCP storage requirements increase by 96 bytes for each unassigned subchannel address between the values defined by HICHAN and LOCHAN.
- All commands (except Sense, Test I/O, and I/O No-Op) issued to unassigned subchannels within the range you specify are rejected.
- A permanently busy (hung) subchannel results from all commands issued to subchannels outside the range you specify. Although the channel adapter recognizes as valid any commands issued for a subchannel address outside this range, the emulation program does not recognize the address and, therefore, ignores any such commands received from the host processor channel.
- An incomplete initial program load (IPL) of the operating system occurs in the host processor if a unit control block (UCB) exists for a device associated with a subchannel outside the range you specify but within the range of the channel adapter. Test I/O and Sense commands, though accepted by the controller, are ignored.

**Note:** If you want to use the dynamic dump facility with a subchannel that is not associated with an emulation-mode line, code CA=TYPE6 or CA=TYPE6-TPS on the LINE definition statement for the channel. For more information, see the description of the CA keyword on page 4-2.

HICHAN identifies the highest subchannel address on each channel adapter associated with any telecommunication link operating in emulation mode.

LOCHAN identifies the lowest subchannel address on each channel adapter with any telecommunication link that operates in emulation mode. The address range defined by HICHAN and LOCHAN applies only to emulation subchannels. The

network control subchannel address cannot lie within this range. The range of emulation subchannel addresses must not include any addresses associated with shared unit control words (UCWs) in the host processor. The subchannel address is the same address coded in the unit channel block (UCB) for MVS.

---

### BSC Telecommunication Links in PEP Mode

Code the following definition statement and keywords to provide NCP with information about the operational characteristics of a BSC line operating in emulation mode.

LINE	DUALCOM USE
------	----------------

DUALCOM on the LINE definition statement determines whether NCP or EP emulates the dual communication interface feature. Code DUALCOM if the BSC telecommunication link emulates a link to an IBM 2701 Data Adapter Unit with this feature. Code the alternate line number of the link formerly attached to the IBM 2701 dual communication interface and the interface associated with the link.

USE specifies whether the line operates initially in network control mode or in emulation mode. If you use the TYPE keyword on the LINE definition statement to specify that this line can operate alternatively in network control mode or emulation mode, you can switch the line from one mode to the other by command from the access method.

#### Sample Definition of a Telecommunication Link in PEP Mode

Figure 20-2 shows an example of how to code the LINE definition statements that describe two communication lines that are attached to an IBM 2701 by the dual communication interface. The two lines are associated with dual communication interfaces A and B; they are assigned communication controller line addresses 020 and 021. The access method in the host processor communicates with these two lines alternately by an emulation subchannel on channel 1.

Notice that the LINE definition statements for the two lines have the following relationships:

- ADDRESS keywords on both definition statements specify the same emulation subchannel on channel 1.
- Each DUALCOM keyword identifies the ADDRESS defined on the other LINE definition statement.
- The DUALCOM keyword on each definition statement identifies the dual communication interface for each line.

LINE1	LINE	ADDRESS=(020,17-1), DUALCOM=(021,A),
*		
LINE2	LINE	ADDRESS=(021,17-1), DUALCOM=(020,B),

*Figure 20-2. Example: Defining Telecommunication Links in PEP Mode*

---

### WTTY Terminals in PEP Mode

Code the following definition statement and keywords to provide NCP with information about data transmission for WTTY terminals operating in emulation mode.

GROUP	DELAY EOB EOT
-------	---------------------

DELAY on the GROUP definition statement specifies whether the WTTY terminals require a line turnaround time of 70 to 80 milliseconds.

EOB identifies the end-of-message sequence received from the WTTY terminals.

EOT defines the character sequence that an NCP in emulation mode recognizes as the end-of-transmission sequence when it is receiving data from WTTY terminals.

---

### Switched Telecommunication Links

Code the following definition statement and keyword to provide NCP with information about the data carrier detect option for a link with start-stop devices.

LINE	CHECK
------	-------

CHECK on the LINE definition statement specifies that NCP is to use the data carrier detect option for the link. Code CHECK if the telecommunication link is a duplex link. This option prevents access to an application program's data by a start-stop device that dials the communication controller over the link at the moment the existing connection to a different device is lost. If you include this option, NCP continuously monitors the data carrier detect signal from the modem to give positive assurance that the switched connection is still established.

See "V.25 Bis" on page 5-7 for more information about V.25 bis support for start-stop lines in emulation mode.

---

## Modems

Code the following definition statement and keywords to provide NCP with information about a modem for a start-stop line.

LINE	DISABLE MODEM
------	------------------

DISABLE on the LINE definition statement specifies whether the modem attached to the telecommunication link requires a long disable timeout when it is disconnecting from the link. Most modems do not require a long timeout; however, if you specify a long disable timeout, the time out duration is 25.6 seconds.

MODEM determines when the link is to be enabled or disabled. You can specify that the link is to be enabled immediately after the communication controller is loaded or the system-reset key is pressed. You can also specify that the link is to be disabled after the controller is loaded or the system-reset key is pressed, and subsequently enabled by command from the access method.

---

## Devices

Code the following definition statement and keywords to provide NCP with information about performance attributes for devices attached to BSC or start-stop lines.

LINE	FEATURE
	TERM

FEATURE on the LINE definition statement specifies which features NCP includes for the devices attached to the link.

The features available for BSC devices are:

- Emulation of the dual-code feature of the IBM 2701 Data Adapter Unit. The dual-code feature allows message transmission over the link in either EBCDIC or ASCII.
- Support of the Society for Worldwide Interbank Financial Telecommunication (SWIFT) network.
- LRC8

The features available for start-stop devices are:

- Immediate end of a receive operation when an end-of-transmission (EOT) is received
- Support of the space ( ' ') character as a downshift control character on WTTY terminals
- Record-checking.

TERM specifies the type of device attached to the telecommunication link. If different types of devices are attached to the link, specify only one of the types.

---

## Control Units

Code the following definition statement and keywords to provide NCP with information about the model number and control unit functions for the transmission control unit attached to a BSC or start-stop line.

LINE	CU
	CUTYPE

CU on the LINE definition statement specifies which transmission control unit functions NCP emulates for the BSC or start-stop line. Define the type of transmission control unit the telecommunication link was attached to before installation of the

## Data Transmission Characteristics

communication controller. You can also code CU to indicate whether to return Intervention Required (IR) or Command Reject (CR) from a WRITE command to a line that is not enabled, when the emulated unit is an IBM 2703.

CUTYPE identifies the type of cluster controller attached to the line. Code CUTYPE if the line has a cluster controller that supports individual BSC stations. If the link operates alternatively in either network control mode or emulation mode, specify the cluster controller type for both this keyword and CUTYPE on the CLUSTER definition statement.

---

## Data Transmission Characteristics

Code the following definition statement and keywords to provide NCP with information about data transmission characteristics for a BSC or start-stop line, how to improve performance, and how to report errors.

LINE	BUFETTE
	BUFSIZE
	PAD
	UNITXC

BUFETTE on the LINE definition statement specifies the number of 4-byte buffers allocated for the telecommunication link. These buffers are used to prevent overruns of data received from the link when the channel is in a slowdown or lockout condition.

BUFSIZE specifies the size of the emulation mode buffers for this line. BSC lines that run in emulation mode have two buffers for data sent or received over the line. Consider providing larger buffers to offer more protection against possible overruns that result from temporary slowdowns of channel operation or from momentary peaks in data traffic through the network. Larger buffers also reduce interrupt-processing overhead for channel operations. Code BUFSIZE only when you define BSC lines in the PEP environment.

PAD causes a communication controller in emulation mode to examine the first bits of trailing pad characters. If the first 4 bits are not all ones, NCP indicates that a data check error has occurred. Code PAD=YES when NCP emulates the functions of the IBM 2703 Transmission Control Unit.

UNITXC specifies whether NCP signals unit-exception status to the access method whenever it receives an end-of-transmission (EOT) character from the BSC link. It is usually appropriate to specify that NCP signal the access method in this way. However, if READ and WRITE commands within the access method are command chained, you might wish to specify that NCP not signal unit-exception status because this breaks the command chain.



---

## Character Transmission

Code the following definition statements and keywords to provide NCP with information about transmission attributes for start-stop devices and how to improve transmission performance.

GROUP	QUIETCT
LINE	RCVCHAR UNITXC

QUIETCT on the GROUP definition statement specifies the elapsed time between the end of a receive operation and the beginning of a transmit operation on the start-stop lines in the group. Code the time interval in *character times*, which is the amount of time required to transmit 1 character. The elapsed time permits the links to become electrically quiet following the receive operation.

RCVCHAR on the LINE definition statement determines whether a start-stop line receives data in burst mode (up to 4 characters at a time) or in character mode (1 character at a time).

**Note:** Selecting character mode severely limits line speeds and can cause scanner loading.

UNITXC specifies whether NCP signals unit-exception status to the access method whenever it receives an end-of-transmission (EOT) character from the start-stop line. It is usually appropriate to specify that NCP signal the access method in this way. However, if READ and WRITE commands within the access method are command chained, you might wish to specify that NCP not signal unit-exception status because this breaks the command chain.

---

## Timeouts

Code the following definition statements and keywords to provide NCP with information about timeouts for start-stop devices and how to improve performance.

GROUP	DSRTO V25DIAL
LINE	QUIET

DSRTO on the GROUP definition statement defines the amount of time, in seconds, that NCP is to wait for the line to become data-set-ready (DSR) before timing out on a ENABLE command to an emulator line.

V25DIAL on the GROUP definition statement defines the amount of time, in seconds, that NCP is to wait for establishment of a dial connection before timing out on a DIAL command to an emulator line.

## Sample Definition of PEP Mode Subchannels

QUIET on the LINE definition statement causes NCP to observe a long quiet timeout, 25.6 seconds, when receiving from the link. A normal timeout is 3 seconds.

---

## Sample Definition of Emulation Mode Subchannels

Figure 20-3 shows how to code emulation mode subchannels for start-stop and BSC lines in a system generation definition.

```
          OPTIONS
          .
          .
          .
C04PEP   BUILD TYPGEN=PEP,
          .
          .
          *****
          *           Start-Stop EP Lines           *
          *   Lines 21-24 are EP lines using subchannels E0-E3   *
          *****
          *
C04SSG1  GROUP LNCTL=SS,
          TYPE=EP,
          .
          .
          .
          *
C04SSL1  LINE ADDRESS=(21,E0-P5),
          .
          .
          .
C04SSL2  LINE ADDRESS=(22,E1-P5),
          .
          .
          .
C04SSL3  LINE ADDRESS=(23,E2-P5),
          .
          .
          .
C04SSL4  LINE ADDRESS=(24,E3-P5),
          .
          .
          .
```

Figure 20-3 (Part 1 of 2). Example: Defining Emulation Mode Subchannels

## Sample Definition of PEP Mode Subchannels

```

*****
*                               BSC EP Lines                               *
*      Lines 51-54 are EP lines using subchannels E4-E7                  *
*****
*
C04BSG1  GROUP LNCTL=BSC,
          TYPE=EP,
          .
          .
          .
*
C04BSL1  LINE ADDRESS=(51,E4-P5),
          .
          .
          .
C04BSL2  LINE ADDRESS=(52,E5-P5),
          .
          .
          .
C04BSL3  LINE ADDRESS=(53,E6-P5),
          .
          .
          .
C04BSL4  LINE ADDRESS=(54,E7-P5),
          .
          .
          .
*****
*                               CHANNEL ADAPTERS                          *
*****
*
C04CAG1  GROUP LNCTL=CA,CA=TYPE6,NCPCA=ACTIVE,TRANSFR=200,
          TIMEOUT=480.0,ISTATUS=ACTIVE,NPACOLL=YES
*
*****
*      CA ADDR - 08  --  PHYSICAL PORT 1                                *
*      TG=255 CONNECT TO HOST C01N                                       *
*****
*
C04CP5   LINE ADDRESS=P5,
          CASDL=420,
          DELAY=0.2,
          DYNADMP=YES,
          HICHAN=E7,
          LOCHAN=E0
*
C04P05A  PU  PUTYPE=5,
          TGN=255
*
          .
          .
          .
GENEND   GENEND

```

Figure 20-3 (Part 2 of 2). Example: Defining Emulation Mode Subchannels



---

## Chapter 21. Defining a Standalone EP Network

This chapter tells how to define the Emulation Program for IBM 3745 communication controllers in a standalone environment (EPSA). For information on defining a PEP environment, please see Chapter 20, "BSC and Start-Stop Devices Operating in PEP Environment" on page 20-1.

EP enables a channel-attached 3745 to perform most of the functions of an IBM 2701 Data Adapter Unit, an IBM 2702 Transmission Control Unit, an IBM 2703 Transmission Control Unit, or any combination of the three. It enables many programs that operate with the 2701, 2702, and 2703 to operate with the 3745 with no modification. These programs include the following:

- IBM Type 1 access methods that support the 2701, 2702, and 2703
- IBM Type 2 or 3 programs that interact with the 2701, 2702, and 2703 in a manner equivalent to IBM Type 1 access method programs
- User-written programs that interact with the 2701, 2702, and 2703 in a manner equivalent to IBM Type 1 access method programs.

Programs that involve timing dependencies and support of certain special and custom features may have to be changed before running EP.

EP permits the use of the same control sequences and data transfers as are used with the 2701, 2702, and 2703. It also provides most of the standard functions of these control units. EP does *not* operate with the following:

- Parallel data adapter
- Synchronous data adapter type 1
- Programmable two-processor switch
- Six-bit transmission code
- 230 400 bps synchronous speed
- Attachment of other than a byte multiplexer channel
- Direct attachment of the IBM 1032 Digital Time Unit
- IBM 2712 Remote Multiplexer attachment features
- Reverse channel feature.

EP enables the 3745 to communicate with any of the following types of terminals, communication control units, and computers. This list is not exhaustive. Other devices that use the same line protocols as a listed device can also be used. Call your IBM marketing representative for more information. The transmission code that EP uses to communicate with the terminals, communication control units, and computers is indicated by numbered references.

### *Terminals:*

- IBM 1030 Data Collection System
- IBM 1050 Data Communication Systems<sup>1,2</sup>
- IBM 1060 Data Communication System
- IBM 2260 Display Station (using IBM 2848 Display Control)

---

<sup>1</sup> Binary Coded Decimal (BCD) code

<sup>2</sup> Extended Binary Coded Decimal (Extended BCD) code

## Defining a Standalone EP Network

- IBM 2265 Display Station (using IBM 2845 Display Control)
- IBM 2740 Communications Terminal (Models 1 and 2)<sup>1,2,3</sup>
- IBM 2741 Communications Terminal<sup>1,2,3</sup>
- IBM 2770 Data Communications System<sup>4,5</sup>
- IBM 2780 Data Transmission Terminal<sup>4,5</sup>
- IBM 3270 Information Display System<sup>4,5,6</sup>
  - IBM 3275 Display Station
  - IBM 3277 Display Station
  - IBM 3284 Printer
  - IBM 3286 Printer
- IBM 3650 Retail Store System (in BSC mode)
- IBM 3660 Supermarket System (in BSC mode)
- IBM 3671 Shared Terminal Control Unit
- IBM 3735 Programmable Buffered Terminal<sup>4,5</sup>
- IBM 3740 Data Entry System
  - IBM 3741 Data Station
  - IBM 3747 Data Converter
- IBM 3767 Communication Terminal
- IBM 3770 Data Communications System
- IBM 3780 Data Communication Terminal<sup>4</sup>
- IBM 3790 Communications System
- IBM Communicating Magnetic Card SELECTRIC
- World Trade teleprinters that use CCITT (Consultative Committee on International Telegraphy and Telephony) No. 2 or No. 5 code on leased point-to-point, leased multipoint, or switched network lines
- Typewriter Terminals using the following line control discipline: WU CPT-TWX (33/35) start-stop code over switched lines

**Note:** The provisions of the IBM Multiple Supplier Systems Policy govern the attachment of non-IBM terminals.

### *Communication Control Units:*

- IBM 2701 Data Adapter Unit<sup>4,5</sup>
- IBM 2715 Transmission Control Model 2<sup>4</sup>
- IBM 3704 Communications Controller<sup>4,5</sup>
- IBM 3705 Communications Controller<sup>4,5</sup>
- IBM 3720 Communication Controller<sup>4,5</sup>
- IBM 3725 Communication Controller<sup>4,5</sup>
- IBM 3745 Communication Controller<sup>4,5</sup>

---

<sup>3</sup> Correspondence code

<sup>4</sup> Extended Binary Coded Decimal Interchange Code (EBCDIC)

<sup>5</sup> USA Standard Code for Information Interchange (USASCII)

<sup>6</sup> Not supported on switched lines

### Computers:

- IBM System/3<sup>4,5</sup>
- IBM System/7<sup>7</sup> (with asynchronous communications adapter) (supported as 2740 Model 1)
- IBM System/7<sup>4,5</sup> (with binary synchronous communications adapter) (supported as System/3 [BSC])
- IBM System/32 (with binary synchronous communications adapter) (supported as SYS3)
- IBM System/360 Model 20 (with BSC Adapter)<sup>4,5</sup>
- IBM System/360 Model 25 (with Integrated Communications Attachment with Synchronous Data Adapter II)<sup>4,5</sup>
- IBM System/370 Model 125 (with Integrated Communications Attachment with Synchronous Data Adapter II)<sup>4,5</sup>
- IBM System/370 Model 135 (with Integrated Communications Attachment with Synchronous Data Adapter II)<sup>4,5</sup>
- IBM 1130 Computing System (with Synchronous Communications Adapter)<sup>4,5</sup>
- IBM 1800 Data Acquisition and Control System (using IBM 1826 Data Adapter Unit with Communication Adapter)<sup>4,5</sup>

The following sections of this chapter give you the “big picture” for coding your EPSA generation. They explain which features and characteristics require which definition statements and keywords. The *Resource Definition Reference* manual gives the details of how to code the statements and keywords. In addition, you should work with a systems designer or systems analyst who determines non-obvious keyword values and gives them to you. **Find out these values before you begin coding your EP.**

---

## How Resources Are Defined to EPSA

You define EPSA by coding a series of definition statements and keywords, called a generation definition. The values you specify on these keywords describe the following:

- Your system
- Your network configuration
- Your generation procedure
- The end of your generation

### Defining Your System

The BUILD definition statement indicates the beginning of your generation definition. On BUILD, you provide information about (1) hardware features of the communication controller, (2) diagnostic aids, (3) program generation specifications, and (4) data control information. The following list gives some examples of what the BUILD definition statement specifies.

<b>Controller</b>	The type of communication controller your EPSA will run in
<b>Program</b>	The type of program to be generated; namely, a program that emulates the operation of transmission control units (IBM 2701, 2702, and 2703)

---

<sup>7</sup> PTTC/EBCD code

## How Resources Are Defined to EPSA

<b>Operating system</b>	The type of operating system (MVS, VM, or VSE) that is to control the generation of EPSA
<b>Load module</b>	The name that is to be assigned to the EPSA load module
<b>Subchannel addresses</b>	The range of processing unit subchannel addresses to be used by EPSA
<b>Options</b>	Optional facilities that may be included in the program, and program generation options that you may want

## Defining Your Network Configuration

Using the GROUP and LINE definition statements, you specify characteristics and functions for the communication lines and line groups.

On GROUP you define characteristics and functions that lines and devices have in common, such as (1) whether the lines are switched or nonswitched, (2) whether this group applies to BSC or SS communication lines or to a channel adapter group (LNCTL=CA), (3) optional or variable characteristics that all lines in the group must have in common, and (4) operation options to be applied to all lines in the group.

On LINE you define characteristics and functions for each line, such as (1) the speed of the line, (2) its address, (3) whether the modem or communication scanner will provide clocking, (4) whether the line and modem constitute a duplex or half-duplex facility, and (5) the number of attempts EP will make to recover from errors occurring during transmission of data over the line. The following list gives examples of some of these characteristics and functions.

<b>Line speed</b>	The speed at which the lines connected to EP operate
<b>Clocking</b>	The type of clocking used by the lines connected to EP
<b>Transmission code</b>	The transmission code used by the binary synchronous communication (BSC) and start-stop (SS) lines connected to EP
<b>Channel Adapter</b>	The channel adapter characteristics, such as, HICHAN and LOCHAN ranges and DYNADMP support.

A summary of the keywords for the GROUP and LINE definition statements is given in Table 21-1 on page 21-5.

## Coding LINE Keywords on the GROUP Definition Statements

Some keywords explained under the LINE definition statement in this book may be coded on the GROUP definition statement in your generation definition. Coding LINE keywords on the GROUP definition statement saves time. For example, five characteristics common to 15 terminals on a line can be specified once on the GROUP definition statement rather than on each of the 15 LINE definition statements. Five keywords are coded instead of 75 (15 x 5).

The characteristic need not be identical for *all* devices in order to define it on the GROUP definition statement. You can code exceptions on the LINE definition statement. Any characteristic you code on the LINE definition statement automatically overrides the characteristic specified on the GROUP definition statement. If, for example, only 12 of the 15 terminals have the same characteristic in common, you still can specify that characteristic on the GROUP definition statement. Then you define the characteristics of the three different terminals on their LINE definition statements.



Table 21-1 on page 21-5 lists all of the keywords that can be defined on the LINE or GROUP definition statements.

- An “X” indicates the definition statement where the keyword is usually coded. The description of the keyword appears under this definition statement.
- A bullet (•) means that the keyword can also be coded on this definition statement.
- The FEATURE keyword has both SS and BSC keywords.

**Note:** You cannot specify the ADDRESS, AUTO, DUALCOM, DYNADMP, HICHAN, LOCHAN, and LIC keywords on the GROUP definition statement; nor can you specify the CHAREC, DELAY, DIAL, EOB, EOT, LNCTL, QUIETCT, REPLYTO, and TEXTTO keywords on the LINE definition statement.

Table 21-1 (Page 1 of 2). Summary of EPSA-Related Keywords for the GROUP and LINE Definition Statements

Keyword	GROUP Definition Statement	LINE Definition Statement	For SS Devices	For BSC Devices	For CAs
ADDRESS		X	•	•	•
AUTO		X	•	•	
BUFETTE	•	X	•		
BUFSIZE	•	X		•	
CHAREC	X		•		
CHECK	•	X	•		
CHNPRI	•	X		•	
CLOCKNG	•	X	•	•	
CODE	•	X		•	
CSPMODE	•	X	•	•	
CU	•	X	•	•	
CUTYPE	•	X	•	•	
DATRATE	•	X	•	•	
DELAY	X		•		
DIAL	X		•	•	
DISABLE	•	X	•	•	
DUALCOM		X		•	
DUPLEX	•	X	•	•	
DYNADMP		X			•
EOB	X		•		
EOT	X		•		
FEATURE	•	X			
HICHAN		X			•
INBFRS		X			•
LNCTL	X		•	•	•
LIC		X	•	•	
LOCHAN		X			•
MODEM	•	X	•	•	
MULTI	•	X	•		
NCPCA	•	X			•
NEWSYNC	•	X		•	
PAD	•	X		•	
QUIET	•	X	•		
QUIETCT	X		•		
REPLYTO	X		•		
RING	•	X	•	•	
SPEED	•	X	•	•	
TADDR	•	X		•	

## How Resources Are Defined to EPSA

Table 21-1 (Page 2 of 2). Summary of EPSA-Related Keywords for the GROUP and LINE Definition Statements

Keyword	GROUP Definition Statement	LINE Definition Statement	For SS Devices	For BSC Devices	For CAs
TERM	•	X	•	•	
TEXTTO	X		•		
TIMEOUT	•	X			•
UNITXC	•	X	•		

### GROUP Definition Statement

The GROUP definition statement represents a grouping of lines having certain characteristics in common. The grouping is called a *physical line group* because it contains lines having certain *physical* attributes in common, such as the following:

- All lines in the group are either nonswitched or switched (lines in a nonswitched group can be point-to-point or multipoint or a combination of the two).
- Either all stations connected to lines in the group are SS, or all are BSC, or all are CAs.

No line can be included in more than one line group.

The GROUP definition statement indicates the beginning of a sequence of LINE definition statements for lines within the group and specifies the following.

#### Switched or nonswitched

Whether the lines are switched or nonswitched

#### SS or BSC

Whether the lines are used for asynchronous (SS) or binary synchronous (BSC) communication

#### CA

This group defines one or more channel link(s)

#### Options

Optional or variable characteristics that all lines in the group must have in common and procedural options to be applied to all lines in the group

### LINE Definition Statement

The LINE definition statement represents one SS or BSC telecommunication line attached to the communication controller. The LINE definition statement specifies the following.

#### Duplex

Whether the communication facility of which the line is a part is a half-duplex or a duplex facility

#### Addresses

The address where the line is attached within the communication controller and the subchannel addresses (within the corresponding processing unit) used by the access method to communicate with stations attached to the line

#### Priority

The priority of the emulation subchannel associated with this line, in respect to other emulation subchannels

#### ACU

The address, within the communication controller, to which the related automatic calling unit (ACU), if any, is attached

<b>Speed</b>	The speed of the line; that is, the rate (in bits per second) at which the controller and stations on the line send data
<b>Clocking</b>	Whether the modem or the scanner is to provide clocking of the telecommunication line
<b>Modem's rate</b>	Whether the modem by which the line is attached to the controller, if a dual data-rate modem, is to operate at the high or low rate
<b>Ring indicator</b>	Whether, for a switched line, the modem operates in ring-indicator mode
<b>Unit emulated</b>	The type of transmission control unit (IBM 2701, 2702, or 2703) that the program is to emulate when communicating with stations over the line represented by this LINE definition statement
<b>Address of dual communication interface</b>	The dual communication interface address, if any, associated with the line [applicable only if the transmission control unit (2701) being emulated has the dual communications interface feature]
<b>Features emulated</b>	Certain features of the transmission control unit being emulated
<b>Station types</b>	The type of SS or BSC station or stations connected to the line
<b>Station features</b>	Certain features with which the stations attached to the line are equipped
<b>Transmission code</b>	The transmission code used by stations on the line (if BSC stations)

## Sequence of LINE and GROUP

All LINE definition statements representing lines in a physical line group must appear after that GROUP definition statement. The last line definition statement of a group may be followed by another GROUP or the GENEND definition statement. Assume, for example, that the first two lines in a configuration have similar attributes, allowing them to be in the same line group. Also assume that the third line has different characteristics, which requires it to be in a different line group. (A single line can constitute a line group.) The definition statement sequence here would be as follows:

```

GROUP
    LINE
    LINE
GROUP
    LINE
    
```

If all the lines were dissimilar, each of the three LINE definition statements would have to be preceded by a GROUP definition statement. For example, a configuration having one SS TWX line, one SS 2260 line, and one BSC line would require three line groups, each consisting of one line. On the other hand, a configuration consisting of three similar lines (for example, three BSC lines) could (but not neces-

## Defining Your System

sarily) be in the same line group, with only one GROUP definition statement immediately preceding the first LINE definition statement.

Most of the characteristics that pertain to the lines in a group can be specified in the GROUP definition statement. This makes it desirable to include similar lines in a single group. A characteristic need not be the same for all the lines in a group to specify that characteristic in the GROUP definition statement. You can code the exceptions on an individual LINE definition statement.

Any characteristic that you code in the LINE definition statement overrides the characteristic specified in the GROUP definition statement. If, for example, all except one of the six lines in a group have the same characteristic in common, you could specify the common characteristic in the GROUP definition statement and the differing characteristic in the LINE definition statement for that exceptional line. If, however, you do not define the characteristic in either definition statement, the default value specified in the LINE definition statement description is assumed.

**Note:** The SS 2260 or 2265 terminals in your network require a GROUP definition statement with LNCTL=SS. The BSC terminals in your network require a GROUP definition statement with LNCTL=BSC. Networks with both SS and BSC line controls coded in this way let you have a more efficient grouping of similar characteristics.

## Defining Your Generation Procedure

The OPTIONS definition statement allows you to selectively control the generation procedure for diagnostic purposes. This definition statement turns traces such as parameter traces, data traces, and procedure traces on and off. It also selectively dumps instances of the major data structures that the generation process uses and runs the generation procedure in FASTRUN mode to check for input errors without creating object modules.

## Defining the End of Your Generation

The GENEND definition statement indicates the end of your generation.

---

## Defining Your System

Before you can generate EPSA, you must define to it several physical and operational characteristics about your configuration. Code the following definition statement and keywords to define these characteristics.

BUILD	NEWNAME
	TYP SYS
	VERSION
	LENAME

NEWNAME specifies a name for your EPSA load module, which will be produced at the end of the generation procedure. You can assign a symbolic name or use the default name.

TYP SYS specifies that your EPSA will be generated by an MVS, VM, or VSE operating system.

VERSION specifies the EP release that you are running.

LENAME is for an EPSA under the VSE operating system only. Use this keyword to specify a unique name for the member containing the link-edit control statements. This unique name is required only when NDF jobs concurrently catalog link-edit cards to the same sublibrary. The member is created by the first step in the EPSA generation procedure and cataloged by the LIBRARIAN to be used in the link-edit step.

### Keywords Ignored by SSP

SSP Version 4 ignores the following keywords on the BUILD definition statement. If you code these keywords, you will receive an informational error message, but you can still generate your EPSA without modifying your generation definition.

BUILD	JOBCARD
	LESIZE
	OBJLIB
	UNIT
	UT1
	UT2
	UT3

## Diagnostic Operations for the Generation Procedure

You can instruct the generation procedure to print a variety of diagnostic information in its generation definition report by coding the OPTIONS definition statement and certain associated keywords. The OPTIONS definition statement lets you generate diagnostic information for only those definition statements that seem to be causing a problem. For more information on using the OPTIONS definition statement for diagnosis, see *NCP, SSP, and EP Diagnosis Guide*.

The following keywords are available on the OPTIONS definition statement for controlling generation diagnosis.

OPTIONS	TRPROC
	NOTRPROC
	TRGLOB
	NOTRGLOB
	TRPARAM
	NOTRPARAM
	TRDATA
	NOTRDATA
	TRSNAP

Use TRPROC when an IBM support representative asks you to run a procedure trace for diagnostic purposes. This keyword starts a trace of the entry and exit for

## Defining Your System

specified subcomponents. Use the TRPROC keyword to trace entry and exit for all modules in certain subcomponents or to trace entry and exit for statement/keyword routines.

NOTRPROC deactivates the above traces.

Use TRGLOB when an IBM support representative asks you to run a global trace for diagnostic purposes. This keyword specifies the global variables for which the global trace is activated.

NOTRGLOB deactivates global trace activity for specified global traces.

Use TRPARM when an IBM support representative asks you to run a parameter trace for diagnostic purposes. This keyword starts input and output parameter tracing for specified subcomponents. Use the TRPARM keyword to trace the input and output parameters of all modules in a certain subcomponent or to trace the input and output parameters for the statement/keyword routines.

NOTRPARM deactivates the above traces.

Use TRDATA when an IBM support representative asks you to run a data trace for diagnostic purposes. This keyword starts the data trace for specified subcomponents or for a data area. Use the TRDATA keyword to trace data for all modules in a certain subcomponent.

Use TRDATA also to specify that you want the generation procedure to:

- Print each component of a statement, length, and type of data when it is known
- Print the internal representation for each statement when it is known
- Print an identifying message for each routine in the Keyword Vector Table (KVT) that gets called
- Trace the generation of linkage editor control cards

NOTRDATA deactivates the above traces and other operations carried out by the TRDATA keyword.

Use TRSNAP if you find incorrect control blocks or other data-related problems. This keyword instructs the generation procedure to print the major data structures that you specify. For example, use the TRSNAP keyword to specify the printing of KVTs, the Symbol Table, the Storage Manager structures, and the Storage Manager data sets.

## Verification of the Generation Definition

It is possible to code a generation definition and test it for syntax errors before attempting a final run, or to generate a NEWDEFN file without creating a load module. Code the following definition statement and keyword to implement either of these NDF functions.

OPTIONS	FASTRUN
---------	---------

FASTRUN specifies that you want the generation procedure to run in FASTRUN mode. FASTRUN causes NDF to check for input errors in the generation definition

without creating control blocks. To use the FASTRUN keyword, be sure your JCL or VM EXEC calls only the NDF program and not the linkage editor. Code FASTRUN on OPTIONS as the first executable statement in the generation definition. For more information, see *NCP, SSP, and EP Generation and Loading Guide*.

## Communication Controller

You must define several physical and operational characteristics about the communication controller in which EPSA will reside. Code the following definition statements and keywords to define these characteristics.

BUILD	MODEL
-------	-------

MODEL specifies that you will be loading EPSA into the IBM 3745 Communication Controller.

### Channel Address

LINE	HICHAN LOCHAN
------	------------------

HICHAN specifies the highest subchannel address on each channel adapter associated with any line attached to EP.

LOCHAN specifies the lowest subchannel address on each channel adapter associated with any line attached to EP.

**Warning:** The address range specified by the HICHAN and LOCHAN keywords applies only to emulation subchannels. The native subchannel address (the load or IPL subchannel address) must not fall within this range.

The range of emulation subchannel addresses must not include any addresses associated with shared unit control words (UCWs) in the host processor. Best storage utilization is achieved by sequential addressing of all emulation subchannels. Each unassigned subchannel address between the values specified by the HICHAN and LOCHAN keywords adds 64 bytes to the EP storage requirements.

Ensure that the values you specify on the HICHAN and LOCHAN keywords correspond to the high and low subchannel addresses actually installed within the communication controller. Failure to do this may cause the following:

- All commands (except Sense, Test I/O, and I/O No-Op) issued to unassigned subchannels within the range you specify will be rejected. Unassigned subchannels are those not specified on the ADDRESS keyword of any LINE definition statement or on the DYNADMP keyword of the BUILD definition statement.
- All commands issued to subchannels outside the range you specify will result in a permanently busy (hung) subchannel. Although the channel adapter recognizes as valid any commands issued for a subchannel address outside this range, EP does not recognize the address and therefore ignores any such commands received from the host processor channel.

## Defining Your System

- If a unit control block (UCB) exists for a device associated with a subchannel outside the range you specify but within the channel adapter's range, initial program load (IPL) of the operating system in the host processor cannot be completed because Test I/O and Sense commands, though accepted by the controller, are ignored.

### Line Characteristics

GROUP	LNCTL
LINE	ADDRESS TAKEOVER

LNCTL specifies the type of line control used for the lines in a group. A group consists of one or more lines that have certain characteristics in common. All lines in a group must use the same type of line control. EP can use three possible line control types: BSC, SS, and CA.

LNCTL=CA means that the definition statements following this GROUP definition statement identify the emulator subchannel ranges and dynadump subchannel assignments.

ADDRESS specifies the relative line number of the line you are defining. This line number is relative to the line numbers of all the lines you are defining to this EP. The line number will be converted to an even address or an even and odd pair of addresses for the line it represents.

#### *Example 1:*

ADDRESS=(32,2E-0): line number 32, subchannel address 2E, channel adapter position 0.

#### *Example 2:*

ADDRESS=(32,2E-0, 17-1, 1C-0): line number 32, subchannel addresses 2E and 1C in channel adapter position 0 and subchannel address 17 in adapter position 1.

The subchannel addresses must be within the range specified by the HICHAN and LOCHAN keywords of the LINE definition statement for the associated channel adapter.

Each subchannel for which a LINE definition statement is included must have the address defined in the communication controller.

The Multiple Subchannel Line Access facility (MSLA) allows EP to communicate over more than one channel adapter, but only one connection is active at any one time. Use ADDRESS to specify the emulation subchannel address or addresses and the channel adapters associated with this line, as in example 2.

TAKEOVER can be used when the controller is attached to several hosts via separate channel adapters, to indicate that this host is to take ownership of the line regardless of the line's status.



## Diagnostic Aids

You must define to EP several diagnostic aids if you want them to be included in your gen. You also must define several characteristics about these and other automatically included diagnostic aids. The definition statements and keywords that define these diagnostic aids and their characteristics are discussed in the following topics.

### Dynamic Dump

LINE	DYNADMP
------	---------

DYNADMP specifies whether you want the dynamic dump utility included for the EP you are defining. The dynamic dump utility is a maintenance and debugging tool that can:

- Obtain, without stopping the program, (1) a storage dump from location 0 through the end of storage of the communication controller; (2) a display, on the operator's console at the host processor, of portions of controller storage (up to 144 bytes) starting at any location; or (3) a dump of only the emulation mode trace table
- Transfer a MOSS or CSP dump
- Activate or deactivate the EP line trace or scanner interface trace functions
- Obtain a dynamic dump of EP trace table entries as they are entered into the trace table, and scanner interface trace entries as they are produced

Use the DYNADMP keyword to also specify the address of the subchannel to be used by EP to transfer dynamic dump data to the access method.

### Branch Trace

BUILD	BRANCH
-------	--------

BRANCH specifies the number of entries you want in the branch trace table. The branch trace is a maintenance and debugging tool used to record the interrupt level and storage address that EP is coming from and going to each time a successful branch is taken. It can be used to diagnose suspected errors in EP. The branch trace is automatically included for every EP SA.

### Line Trace

BUILD	LINETRC
-------	---------

LINETRC specifies the total number of scanner interface trace lines that are active at the same time and the number of 512-byte blocks to be contained in the trace table. The line trace is a maintenance and debugging tool used to record the activity on lines in the network.

## Defining Characteristics and Functions Common to BSC and SS Devices

### Line Test

BUILD	TEST
-------	------

TEST specifies whether EP is to include the panel-initiated line test function. The test routines can be initiated from the MOSS console of the communication controller only if you specify TEST=YES. Refer to IBM 3745 Communication Controller operating manual for more information about the panel-initiated line test function.

### EP Buffers

BUILD	BFRS
-------	------

BFRS specifies the size, in bytes, and the number of buffers to be allocated for the free buffer pool.

---

## Defining Characteristics and Functions Common to BSC and SS Devices

You must define the relationship between EP and the devices attached to it.

### Control Units

LINE	CU CUTYPE
------	--------------

CU specifies which transmission control unit functions EP is to emulate for the line you are defining. The value you specify here is the type of transmission control unit that the line was attached to before installation of the communication controller.

CUTYPE is for a line you are defining that has any clustered stations attached. Use this keyword to specify the type of cluster controller to which the individual devices in the clustered station are attached.

### Line Characteristics

LINE	CLOCKNG CSPMODE DUPLEX SPEED
------	---------------------------------------

CLOCKNG specifies whether the modem or the communication scanner for the data line you are defining is to provide clocking. External clocking is provided by a modem, whether the modem is a separate unit or built into the controller. Internal clocking (also known as business machine clocking) is provided by the scanner.

## Defining Characteristics and Functions Common to BSC and SS Devices

CSPMODE specifies the mode in which this line is to operate. BSC lines can only operate in normal mode.

DUPLEX specifies whether the line and modem constitute a half-duplex or duplex facility. This keyword represents the characteristics of the complete communication path, including common-carrier lines and equipment and the modems at both ends of the path. *Be careful not to confuse this with half-duplex or duplex data transfer.* This keyword specifies only the physical characteristic of the line, whether it is made up of a two-wire circuit or a four-wire circuit.

SPEED specifies the data rate for the line you are defining. This line must have internal clocking; otherwise it is ignored. This rate represents the rate at which the devices attached to the line send and receive data to and from EP.

### Switched Lines

GROUP	DIAL V25DIAL
LINE	AUTO

DIAL specifies whether the lines in the group you are defining require switched line control procedures.

V25DIAL on the GROUP definition statement defines the amount of time, in seconds, that EP is to wait for establishment of a dial connection before timing out on a DIAL command to an emulator line.

AUTO specifies whether an automatic calling unit (ACU) is installed for the line you are defining. If an ACU is installed, use this keyword to also specify the interface address of the calling unit.

### Modem Characteristics

LINE	DATRATE DISABLE MODEM
------	-----------------------------

DATRATE specifies whether the modem is a dual-rate modem. If the modem is a dual-rate modem, and if the rate can be controlled by the emulation program, use this keyword to specify also whether the line attached to this modem is to operate at a high rate or a low rate.

DISABLE specifies whether the modem attached to the line you are defining requires a long disable timeout when it is disconnecting from the line. Most modems do not require a long timeout. If you specify a long timeout, a 25.6-second timeout will be provided.

MODEM specifies whether the line you are defining

## Defining Characteristics and Functions for BSC Devices

- Is enabled immediately after the communication controller has been loaded or the System Reset key has been pressed, or
- Is disabled after the controller has been loaded or the System Reset key has been pressed, and then must be enabled by command from the access method

You can also use this keyword to specify whether the modems to which this line is attached are from the Nippon Telegraph and Telephone Company.

### Modems for a Switched Line

LINE	RING
------	------

RING specifies whether the modem has the ring-indicator interface. If you are not sure that your modem has this feature, ask the supplier or installer of the modem. If you specify that the modem has the ring-indicator interface, outgoing calls cannot be made.

**Note:** Specifying this feature for a modem that does not have it can result in unnecessary delay in establishing the connection.

### Device Type

LINE	TERM
------	------

TERM specifies the type of device attached to the line you are defining. If different types of devices are attached to the line, specify only one of the types.

---

## Defining Characteristics and Functions for BSC Devices

For any BSC devices attached to EP, you must define to EP their physical and operational characteristics and their relationship with EP. These characteristics are defined in addition to those defined using the definition statements and keywords discussed earlier in this chapter.

### Line Priority

LINE	CHNPRI
------	--------

CHNPRI specifies the priority of the emulation subchannel associated with the line you are defining. The priority can be either normal or high. Normal priority is ordinarily appropriate unless the data rate of the line is 19200 bps or more and most of the remaining lines are slow-speed lines (2400 bps or less).

## Device Features

LINE	FEATURE
------	---------

FEATURE specifies which features you want EP to include for the BSC devices attached to the line you are defining. These features are:

- Emulation of the dual-code feature of the IBM 2701 Data Adapter Unit, which allows message transmission over the line in either EBCDIC or USASCII
- Support of the Society for Worldwide Interbank Financial Telecommunication (SWIFT) network
- LRC8

## Modems

LINE	NEWSYNC
------	---------

NEWSYNC specifies whether the communication controller supplies the new-sync signal to the modem attached to the controller for the line you are defining. You can specify that EP supply the new-sync signal only if (1) the modem can respond to the new-sync signal, (2) the line is a duplex line, and (3) more than one secondary modem is attached to the line. Consult the supplier or installer of the modem for further information about the new-sync signal.

**Note:** If only one device is attached to the line you are defining, you must specify that the controller *not* send the new-sync signal.

## Communication Controllers Connected by a BSC Line

LINE	TADDR
------	-------

TADDR specifies the station (or station and group) address you want to assign to the communication controller you are defining, if it is to represent a tributary station on a multipoint BSC line.

Use this keyword to specify the hexadecimal representation of the station address and the group address. Each address must be equivalent to the address that the access method sends to solicit input from the tributary controller.

## Line Characteristics

LINE	DUALCOM
------	---------

Use DUALCOM if you are defining a line that emulates a line attached to an IBM 2701 Data Adapter Unit with the dual communication interface feature. Use this

## Defining Characteristics and Functions for BSC Devices

keyword to specify the alternative relative line number of the line formerly attached to the 2701 dual communication interface. In addition, use this keyword to specify which interface the line you are defining corresponds to.

**Example:** Assume that two communication lines were attached to an IBM 2701 by the dual communication interface. Assume also that the two lines corresponded to dual communication interfaces A and B respectively. These two communication lines are now attached to the communication controller line addresses 020 and 021. Assume that the access method in the host processor communicates with these two lines alternately by emulation subchannel 017.

You specify the respective LINE definition statements for the two lines so that all of the following apply:

- The ADDRESS keywords of both specify the same emulation subchannel, 017.
- Each DUALCOM keyword specifies the line address designated in the ADDRESS keyword of the *other* LINE definition statement.
- The DUALCOM keyword of each definition statement specifies the interface—A or B—to which the lines formerly corresponded when attached to the 2701:

```
LINE1 LINE ADDRESS=(020,17),          LINE2 LINE ADDRESS=(021,17),  
      DUALCOM=(021,A),                DUALCOM=(020,B),
```

## Buffer Size

LINE	BUFSIZE
------	---------

Use BUFSIZE if you are defining a line that is attached to a normal-mode line. Use this keyword to specify the size you want the EP buffers to be for this line. Each line has two buffers for data being sent or received over the line. The value you specify on this keyword becomes the size of each buffer. This value also becomes the amount of data (up to 32 bytes) that will be transferred over the channel to the access method without interruption. If you specify a value higher than 32 for the size of the EP buffers, the amount of data transferred over the channel without interruption will still be 32 bytes.

Specifying larger buffers offers more protection against possible overruns than does specifying smaller buffers. Overruns can result from temporary slowdowns of channel operation or from momentary peaks in data traffic through the network. Use of larger buffers also results in less interrupt-processing overhead for channel operations.

## Data Characteristics

LINE	CODE PAD
------	-------------

CODE specifies the transmission code EP is to use when communicating with the BSC devices attached to the line you are defining. The code you specify on this

keyword also informs EP which line control scheme is to be used; the transmission code and the line control scheme are related for BSC devices.

Use the PAD keyword if you are defining EP to emulate the functions of the IBM 2703 Transmission Control Unit. Use PAD to specify whether you want EP to verify the first 4 bits of trailing pad characters it receives from the data line you are defining. If you specify that you want EP to check the first 4 bits of trailing pad characters, it will check each pad character received and indicate a data check error if the first 4 bits are not all 1's.

---

## Defining Characteristics and Functions for SS Devices

For any SS devices attached to EP, you must define to EP their physical and operational characteristics and their relationship with EP. These characteristics are defined in addition to those defined using the definition statements and keywords discussed earlier in this chapter.

### Response Mode

LINE	UNITXC
------	--------

UNITXC indicates whether you want EP to signal unit-exception status to the access method whenever EP receives an end-of-transmission (EOT) character from the line you are defining. Having EP signal the access method in this way is usually appropriate. However, if read and write commands within the access method are chained, you might want to specify that EP not signal unit-exception status because this will break the command chain.

### Switched Lines

LINE	CHECK MULTI
------	----------------

Use the CHECK keyword if you are defining a duplex line. CHECK specifies whether you want EP to use the data carrier detect option for the line. Use of this option prevents access to an application program's data by an SS device that dials the communication controller over this line at the moment the existing connection to a different device is lost. If you specify that this option is to be included, EP will continuously monitor the data carrier detect signal from the modem to give positive assurance that the switched connection is still established.

MULTI specifies whether the line represented by this definition statement connects the communication controller to (1) one or more IBM 2845 or IBM 2848 display controllers equipped with multipoint line control, or (2) a single display controller equipped with point-to-point line control.

### Device Features

LINE	FEATURE
------	---------

The FEATURE keyword specifies the features for certain SS devices attached to the line you are defining. These features are:

- Immediate end of a receive operation when an EOT is received
- Record checking
- Reaction to space characters as downshift characters (WTTY only)
- Support of the Society for Worldwide Interbank Financial Telecommunication (SWIFT) network

### Data Characteristics

LINE	BUFETTE
------	---------

BUFETTE specifies the number of 4-byte buffers allocated for the telecommunication link. These buffers are used to prevent overruns of data received from the link when the channel is in a slowdown or lockout condition.

### Character Transmission

GROUP	CHAREC QUIETCT RCVCHAR
-------	------------------------------

Use CHAREC if TWX teletypewriter terminals are attached to the lines in the group you are defining. Use this keyword to specify the message-ending characters to be recognized by EP when receiving data from these devices. When EP receives these characters on a line, it signals channel-end and device-end status to the emulation subchannel associated with the line.

QUIETCT specifies the elapsed time between the end of a receive operation and the beginning of a transmit operation on the start-stop lines in the group. Code the time interval in *character times*, which is the amount of time required to transmit 1 character. The elapsed time permits the links to become electrically quiet following the receive operation.

RCVCHAR determines whether a start-stop line receives data in burst mode (up to 4 characters at a time) or in character mode (1 character at a time).



## Timeouts

LINE	QUIET
------	-------

QUIET causes EP to observe a long quiet timeout, 25.6 seconds, when receiving from the link. A normal timeout is 3 seconds.

## WTTY Terminals

GROUP	DELAY EOB EOT
LINE	FEATURE

DELAY specifies whether the WTTY terminals attached to the lines in the group require a line turnaround time of 70 to 80 milliseconds.

EOB specifies the end-of-block (end-of-message) sequence received from the WTTY terminals attached to the lines in the group.

EOT specifies the character sequence that EP recognizes as the end-of-transmission sequence when it is receiving from the WTTY terminals attached to the lines in the group.

FEATURE specifies whether EP is to react to space characters received from WTTY terminals as downshift characters.

## Performance Characteristics

Several operational characteristics about the relationship of EP to the resources attached to it affect the performance of the network. The effect these operational characteristics have depends on how you define them. In most cases, you will find it difficult to determine how your network performs until all the resources are installed and fully operational. Therefore, you might need to change the values you specify on the keywords discussed in this topic after you have a chance to observe how efficiently your network is operating.

Code the following keywords on the GROUP definition statement to control the performance of your network.

GROUP	REPLYTO TEXTTO
-------	-------------------

REPLYTO specifies a reply timeout value for the lines in the group. If EP does not receive a response to a poll, selection, or message text before the specified time expires, a timeout error is generated, and the appropriate error recovery procedure is initiated.

## Defining Characteristics and Functions for SS Devices

TEXTTO specifies a text timeout value for the lines in the group. If the interval between any two successive scanner text interrupts exceeds the value you specify for TEXTTO, EP ends the read or invite operation with a text timeout error indication.

---

## Part 5. Defining Diagnostic Aids and Network Management Facilities

<b>Chapter 22. Diagnostic Operations for the Generation Procedure</b> . . . . .	22-1
Procedure Tracing . . . . .	22-1
Parameter Tracing . . . . .	22-1
Data Tracing . . . . .	22-1
Data Printing . . . . .	22-2
Global Tracing . . . . .	22-2
<b>Chapter 23. Defining Diagnostic Aids</b> . . . . .	23-1
Channel Adapter Trace . . . . .	23-1
Channel Adapter IOH Trace . . . . .	23-1
Address Trace . . . . .	23-2
Branch Trace . . . . .	23-2
Diagnostic Tests and Traces . . . . .	23-2
Link Problem Determination Aid . . . . .	23-4
Diagnostic Aids . . . . .	23-4
LPDA Mode . . . . .	23-5
Migration Mode (LPDA-1) . . . . .	23-6
Normal Mode (LPDA-2) . . . . .	23-10
Switched Telecommunication Links . . . . .	23-15
Multiple Local Modem Support . . . . .	23-16
Monitoring Virtual Route Congestion . . . . .	23-18
Deactivating an Out-of-Sequence Virtual Route . . . . .	23-18
Monitoring Transmission Group Performance . . . . .	23-18
Monitoring for Excessive Buffer Usage by a Peripheral Resource . . . . .	23-19
<b>Chapter 24. Network Performance</b> . . . . .	24-1
Defining NCP Buffer Size . . . . .	24-1
Reaching the Buffer Limit . . . . .	24-3
Data Flow Control . . . . .	24-3
Timeout Values . . . . .	24-4
Service Order Table . . . . .	24-4
Defining Session Pacing . . . . .	24-6
Data Transfer . . . . .	24-6
Timeouts . . . . .	24-10
Initially Inhibiting NCP Functions . . . . .	24-12
Transmission Interrupts . . . . .	24-14
Controlling Adapter Overrun Errors . . . . .	24-14
Session Accounting . . . . .	24-15
Network Performance Data Collection . . . . .	24-16
Basic Data Collection . . . . .	24-16
Data Collection by Transmission Priority . . . . .	24-18
Session Accounting for IBM Special Products or User-Written Code . . . . .	24-19
MTA Terminals . . . . .	24-20
Link Session Priority . . . . .	24-21
<b>Chapter 25. Backup and Recovery Procedures</b> . . . . .	25-1
Defining Automatic Network Shutdown . . . . .	25-1
Error Recovery and Recording . . . . .	25-4
Backup Sessions for SDLC Devices . . . . .	25-6



---

## Chapter 22. Diagnostic Operations for the Generation Procedure

The generation procedure prints a variety of diagnostic information in its generation definition report if you code the OPTIONS definition statement and certain associated keywords. The OPTIONS definition statement lets you generate diagnostic information for only those definition statements that appear to be causing a problem. This chapter describes the OPTIONS definition statement and the keywords used for diagnosis. For more information, see *NCP, SSP, and EP Diagnosis Guide*.

---

### Procedure Tracing

If an IBM support representative asks you to run a procedure trace for diagnostic purposes, code the following definition statement and keywords to provide NCP with information about when to activate and deactivate the trace.

OPTIONS	TRPROC
	NOTRPROC

TRPROC on the OPTIONS definition statement activates a trace of the entry and exit for specified subcomponents. TRPROC traces the entry and the exit for all modules in certain subcomponents or the entry and the exit for statement and keyword routines. NOTRPROC deactivates a procedure trace.

---

### Parameter Tracing

If an IBM support representative asks you to run a parameter trace for diagnostic purposes, code the following definition statement and keywords to provide NCP with information about when to activate and deactivate a parameter trace.

OPTIONS	TRPARAM
	NOTRPARAM

TRPARAM on the OPTIONS definition statement activates input and output parameter tracing for specified subcomponents. TRPARAM traces the input and output parameters of all modules in a certain subcomponent or the input and output parameters for the statement and keyword routines. NOTRPARAM deactivates the parameter trace.

---

### Data Tracing

If an IBM support representative asks you to run a data trace for diagnostic purposes, code the following definition statement and keywords to provide NCP with information about when to activate and deactivate a data trace.

## Global Tracing

```
OPTIONS      TRDATA
             NOTRDATA
```

TRDATA on the OPTIONS definition statement activates the data trace for specified subcomponents or for a data area, traces data for all modules in a certain subcomponent, or specifies that the generation procedure is to perform the following activities:

- Print each component of a statement, including length and type of data, as soon as it is known
- Print the internal representation for each statement as soon as it is known
- Print an identifying message for each routine in the keyword vector table (KVT) that is called
- Trace the generation of linkage editor control cards.

NOTRDATA deactivates the data trace and other operations performed by TRDATA.

---

## Data Printing

If you encounter incorrect control blocks or other data-related problems, code the following definition statement and keyword to provide NCP with information about printing data.

```
OPTIONS      TRSNAP
```

TRSNAP on the OPTIONS definition statement instructs the generation procedure to print the major data structures you define. For example, use TRSNAP to specify the printing of KVTs, the symbol table, storage manager structures, and storage manager data sets.

---

## Global Tracing

Use the global variable trace if an IBM support representative tells you to run a global trace for diagnostic purposes. The dynamic global trace facility enables you to activate and deactivate global traces without recompiles or relinks. You can trace up to 24 global variables at one time and independently control each trace, because you can activate or deactivate any global trace at any time.

Code the following definition statement and keywords to provide NCP with information about a global trace.

```
OPTIONS      TRPROC
             TRGLOB
             NOTRGLOB
```

TRPROC on the OPTIONS definition statement defines the subcomponent modules to be traced.

TRGLOB identifies and activates the global variables you wish to trace. You can specify a maximum of 24 global variables. TRGLOB also lets you suppress, and then resume, printing of global trace data.

NOTRGLOB deactivates the global variable trace for the globals specified.





---

## Chapter 23. Defining Diagnostic Aids

You can include certain diagnostic aids in your NCP. This chapter discusses the definition statements and keywords you need to define these diagnostic aids and their attributes. For more information on NCP diagnostic aids, refer to *NCP, SSP, and EP Diagnosis Guide*.

---

### Channel Adapter Trace

The channel adapter trace is a maintenance and debugging tool used to trace channel adapter interrupts over type 6 and type 7 channel adapters only. It can aid you in diagnosing suspected channel adapter hardware errors and NCP errors. It can also monitor all channel external registers. You can trace any combination of up to four channel adapters. An entry is placed in a table for each level 3 interrupt.

The channel adapter trace facility does not interfere with normal operations of the controller; however, performance can diminish somewhat because of the additional processing needed. The amount of decrease in performance depends on how heavily the controller is currently loaded and how many channel adapters are traced at one time. The channel adapter trace can be controlled by line trace commands from VTAM and the NetView program.

**ESCON:** The channel adapter trace cannot be used over ESCON adapters.

Code the following definition statement and keyword to provide NCP or EP with information about the channel adapter trace.

BUILD	CATRACE
-------	---------

CATRACE on the BUILD definition statement causes NCP or EP to include the channel adapter trace facility in the system generation definition. CATRACE also specifies the number of entries in the trace table.

---

### Channel Adapter IOH Trace

The channel adapter input/output halfword (IOH) trace is a maintenance and debugging tool that traces information flowing through a single type 6 or type 7 channel adapter.

**ESCON:** The channel adapter IOH trace cannot be used over ESCON adapters.

Code the following definition statement and keyword to provide NCP with information about the channel adapter IOH trace.

BUILD	CAIOTRC
-------	---------

CAIOTRC on the BUILD definition statement causes NCP to include the channel adapter IOH trace function in the system generation definition.

### Address Trace

The address trace is a maintenance and debugging tool that records the contents of selected areas of communication controller storage, general registers, and external registers at each successive interrupt. Perform address tracing only on telecommunication links operating in network control mode.

Code the following definition statement and keyword to provide NCP with information about the address trace facility.

BUILD	TRACE
-------	-------

TRACE on the BUILD definition statement causes NCP to include the address trace facility in the NCP system generation definition. TRACE also specifies the number of 16-byte entries contained in the trace table.

---

### Branch Trace

Use the branch trace, a maintenance and debugging tool, to record the interrupt level and storage address that NCP or EP branches to and returns from each time a successful branch is taken. The branch trace, used to diagnose suspected errors in NCP, is automatically included for every NCP or EP.

Code the following definition statement and keyword to provide NCP or EP with information about the branch trace facility.

BUILD	BRANCH
-------	--------

BRANCH on the BUILD definition statement specifies the number of entries you want in the branch trace table.

---

## Diagnostic Tests and Traces

The line trace is a maintenance and debugging tool that records the activity on the telecommunication links connected to NCP each time a level 2 interrupt occurs for a particular link. Snap traces provide diagnostic information for specific resources:

- NCP snap trace for NTRI and 3745 frame-relay resources
- CSS snap trace for 3746 Model 900 resources
- IP snap trace for internet resources
- HPR snap trace for APPN HPR resources.

Use the snap trace under the direction of your IBM support representative. Online terminal test facilities are maintenance and debugging tools used by terminal or console operators to request that a variety of tests be performed on a telecommunication link. Use them to diagnose suspected link and terminal failures.

Code the following definition statement and keywords to provide NCP with information about the NCP line trace, snap trace, and terminal test facilities.

BUILD	LINETRC
	LTRACE
	NCPTRACE
	OLT
	IPSNAP
	HPRSNAP

LINETRC on the BUILD definition statement invokes the scanner interface trace for telecommunication links operating in emulation mode and defines the number of concurrent scanner interface traces. The scanner interface trace, which is automatically included for NCP or EP, is a maintenance and debugging tool that records the activity within the scanners installed on the controller.

LTRACE defines the number of line traces that can run at the same time. Trace information is placed in buffers, obtained as needed from the buffer pool, and transmitted to the host processor, where the trace information is accumulated in a file.

Line trace activity does not interfere with normal operation of a link; however, performance can diminish somewhat because of the additional processing needed each time a character-service or buffer-service interrupt occurs on the line being traced. The performance of NCP can be affected similarly, but to a lesser extent. In both cases, the decrease in performance depends upon the type of scanner servicing the line and the degree to which the communication controller is currently loaded. The line trace facility is automatically included for every NCP.

**Note:** NCP does not support line trace for communication lines controlled by user-written control code that includes such products as X.25 NCP Packet Switching Interface (NPSI). NCP passes the request to start or stop the line trace (or scanner interface trace) to the user-written I/O code. The user code then controls the trace.

NCPTRACE specifies that a snap trace is to be generated. The trace is activated when you load NCP.

**Note:** NCPTRACE has replaced NTRISNAP, which is still valid. You must code the same value for both keywords if you decide to use both keywords.

OLT causes NCP to include online terminal test facilities.

IPSNAP specifies whether the NCP snap trace is to be enabled for internet resources. You can trace NCPROUTE dynamic routing updates, IP datagrams received or routed by NCP, or both.

HPRSNAP specifies whether you want the NCP snap trace enabled for APPN HPR resources. You can trace one or both of the following:

- Route setup requests that NCP receives and routes for route setup processing.
- Network layer packets (NLPs), which are the basic transmission units for APPN HPR, that NCP receives and routes for ANR.

---

### Link Problem Determination Aid

Link problem determination aid (LPDA) is an optional function that enables NCP to gather diagnostic information from an IBM synchronous, externally clocked modem that accepts LPDA commands. When a user initiates an LPDA command, it is called a solicited test; when NCP initiates an LPDA command, it is called an unsolicited test. NCP issues an LPDA command when a link error or a statistical event, such as reaching a user-defined threshold, occurs. There are two LPDA modes: migration mode (LPDA-1) and normal mode (LPDA-2). For information about running LPDA tests on a physical unit associated with a line, see “Diagnostic Aids.”

**Note:** In discussions concerning LPDA for multiport and DMPX modems, the terms *port* and *channel* are synonymous. Although *port* is the more commonly used term, *channel* can be used in sections describing LPDA. In this discussion of modems and LPDA, the terms *link* and *line* are also used interchangeably.

### Diagnostic Aids

LPDA is a set of test commands that determine which network component is causing an error in the network. LPDA can be performed by any of the following devices:

- IBM 3833, 3834, 3863, 3864, 3865, or 3868 modems
- IBM 5865, 5866, or 5868 modems
- IBM 3867 Link Diagnostic Unit
- IBM 7825, Model 16, and 7865, Model 18 integrated modems
- IBM 7861 and 7868 modems.

**Note:** You cannot run LPDA on a TSS or an HPTSS adapter used for frame relay.

Code the following definition statement and keywords to provide NCP with information about LPDA.

PU	LPDA
	SRT

Provide LPDA testing by providing NCP with information about the number of transmission retries to be attempted before LPDA testing occurs.

LPDA on the PU definition statement specifies whether you wish to run LPDA tests for a physical unit on a line.

SRT defines the thresholds for the number of error retries and the total number of transmissions. When either of these thresholds is reached, NCP builds an error event record using record maintenance statistics (RECMS) for LPDA-1 or no LPDA, or a network management vector transport (NMVT) request/response unit (RU) for LPDA-2. NCP then performs an LPDA test if you requested it on the physical unit definition.

**Notes:**

1. Specify NO as the third suboperand of SRT to prevent NCP from performing the LPDA test when the total number of transmissions counter reaches the threshold. This eliminates delays caused by LPDA tests performed for non-error situations.
2. For LPDA-2 channelized lines on ports B, C, or D, NCP routes all tests through the port A line. Because this impacts performance on the port A line, code high threshold values for SRT, or use the maximum default values. This reduces performance degradation on the port A line that runs the LPDA tests for ports B, C, and D.
3. You can code SRT on the PU definition statement to define reporting thresholds for NTRI logical lines.

For more information on LPDA tests for ports B, C, or D, see “Normal Mode (LPDA-2)” on page 23-10.

**LPDA Mode**

Code the following definition statement and keyword to provide NCP with information about the LPDA mode.

LINE	LPDATS
------	--------

LPDATS on the LINE definition statement specifies the LPDA mode. Code LPDA1, LPDA2, or NO. LPDATS=LPDA1 and LPDATS=LPDA2 are valid for TSS or HPTSS SDLC lines and BSC lines only. Code LPDATS=NO (or let LPDATS default to NO) for a line when MODE=SEC for the line.

**3746 Model 900 SDLC Lines:** Code LPDATS=LPDA2 or LPDATS=NO.

You can specify LPDATS=LPDA2 for a line whether the line is primary mode (MODE=PRI) or secondary mode (MODE=SEC), but only if the local modem is defined as the primary. However, the results are unreliable if an LPDA-2 test is initiated at the same time from both sides of a link. If both the primary and secondary lines are defined as LPDATS=LPDA2, NCP can initiate unsolicited LPDA-2 tests for both lines at the same time. To avoid this, code LPDATS=LPDA2 for only one side of the link, or ensure that an NMVT RU is processed with a Set Link Attributes control vector to disable LPDA-2 for one side before you enable it for the other.

Lines defined as LPDA-1 cannot share the same channelized modem as lines defined as LPDA-2. However, lines defined as LPDA-2 can share the same LPDA-2 channelized modem as lines without LPDA.

Table 23-1 on page 23-6 shows the LPDA modes and configurations supported for various modems. See “Migration Mode (LPDA-1)” on page 23-6 and “Normal Mode (LPDA-2)” on page 23-10 for descriptions of the CHNLZ and TAILING keywords.

## Link Problem Determination Aid

Table 23-1. Modem Models and LPDA Modes and Configurations Supported

Modem	Mode	LPDA-1	LPDA-2	CHNLZ	TAILING
3833	Migration	X			
3834	Migration	X			
3863	Migration	X			
3864	Migration	X			
3865	Migration	X		X	X
3868	Migration	X			
5822	Normal		X		X
5865	Migration	X			
5866	Migration	X			
5868	Migration	X			
5865	Normal		X		X
5866	Normal		X		X
5868	Normal		X		X
7861	Normal		X	X	X
7868	Normal		X	X	X
7861	Migration	X			
7868	Migration	X			
3867 <sup>1</sup>	Migration	X			

<sup>1</sup> Other types of modems operate in conjunction with the IBM 3867 link diagnostic unit to accept and provide responses to LPDA commands.

### Migration Mode (LPDA-1)

NCP runs LPDA-1 tests in response to solicited or unsolicited requests. Solicited requests are request for maintenance statistics (REQMS) network commands that are sent from the host. Unsolicited requests are RECMS that are sent to the host.

**3746 Model 900 SDLC Lines:** NCP does not support LPDA-1 tests for 3746 Model 900 SDLC lines.

Code the following definition statement and keyword to provide NCP with information about LPDA-1 tests.

```
LINE          CALINE
              CHANLA
              CHNLZ
              CLINES
              CORNUM
              DATRATE
              TAILING
```

CALINE on the LINE definition statement names the link attached to channel A of a modem. Use CALINE when the link is attached to channel B, C, or D and define this link as tailed.

CHANLA specifies whether the link is attached to channel A, the LPDA control channel of the modem. Define this link as nontailed.

CHNLZ identifies that the link is attached to a modem with the data multiplexer feature. Specify CHNLZ=YES only for nonswitched telecommunication links.

CLINES names the other links attached to channel B, C, or D of the same modem if the link is attached to channel A.

CORNUM defines a 2-byte correlation number for all the lines attached to a particular channelized modem. A maximum of four lines can have the same correlation number in your NCP generation. Each data multiplex modem must have a unique CORNUM. A maximum of four links can have the same CORNUM. You cannot code lines with the same CORNUM as LPDA-1 and LPDA-2.

**Note:** Lines with different protocols (such as SDLC, BSC, or start-stop) can share the same channelized modem. For start-stop lines, LPDA-2 is not supported. However, if you specify LPDATS=NO, you can code the CHNLZ and CORNUM keywords.

If you use a channelized modem, all lines must be attached either directly to the IBM 3745 or to the 3746 Model 900. You may not use a combination of 3746 Model 900 and IBM 3745-attached lines.

DATRATE specifies a high or low data rate for a dual-rate modem.

TAILING indicates whether a second-level LPDA circuit (second line segment) is attached to the line. If you specify TAILING=YES, do not use X'FD' or X'FF' for the station address of an SDLC device, or as the first character of the polling or addressing sequence for a BSC device.

### Sample Definition of LPDA-1 Channelized Links

Figure 23-1 illustrates LPDA-1 channelized and tailed modems on SDLC or BSC lines.

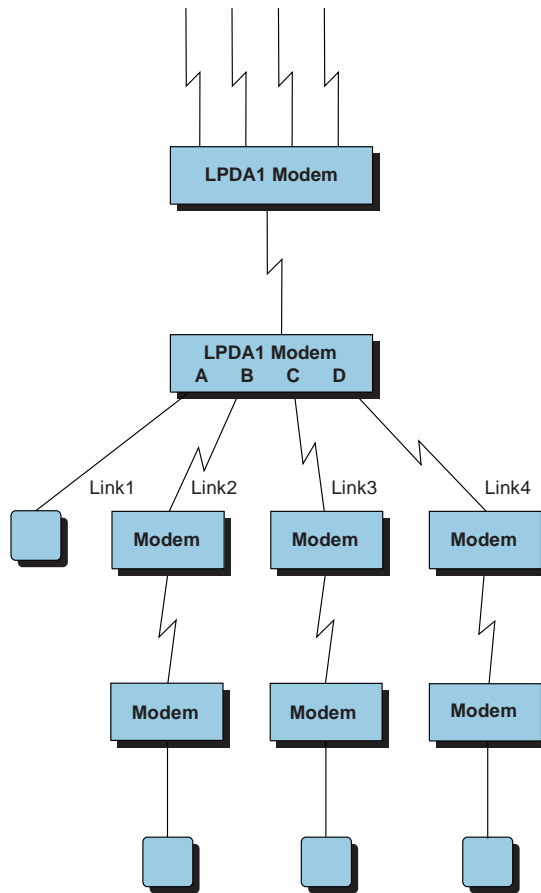

Figure 23-1. LPDA-1 Channelized and Tailed Modems on SDLC or BSC Links



Figure 23-2 shows how to code the LINE statements to define the links for an LPDA-1 channelized modem.

```

LINE1  LINE  SPEED=2400,
           LPDATS=(LPDA1,3867), LPDA supported in migration mode
           CHNLZ=YES,           Attached to channelized modem
           CORNUM=24,           Correlation number for this modem
           CHANLA=YES,          This is channel A
           CLINES=(LINE2,LINE3,LINE4), Other channel lines
           .
           .
           .
*
LINE2  LINE  SPEED=2400,
           LPDATS=(LPDA1,3867), LPDA supported in migration mode
           CHNLZ=YES,           Attached to channelized modem
           CORNUM=24,           Correlation number for this modem
           CHANLA=NO,           This is not channel A
           CALINE=LINE1,        Channel A is LINE1
           TAILING=YES,         2nd link segment attached (tailed)
           .
           .
           .
*
LINE3  LINE  SPEED=2400,
           LPDATS=(LPDA1,3867), LPDA supported in migration mode
           CHNLZ=YES,           Attached to channelized modem
           CORNUM=24,           Correlation number for this modem
           CHANLA=NO,           This is not channel A
           CALINE=LINE1,        Channel A is LINE1
           TAILING=YES,         2nd link segment attached (tailed)
           .
           .
           .
*
LINE4  LINE  SPEED=2400,
           LPDATS=(LPDA1,3867), LPDA supported in migration mode
           CHNLZ=YES,           Attached to channelized modem
           CORNUM=24,           Correlation number for this modem
           CHANLA=NO,           This is not channel A
           CALINE=LINE1,        Channel A is LINE1
           TAILING=YES,         2nd link segment attached (tailed)
           .
           .
           .

```

Figure 23-2. Example: Defining an LPDA-1 Channelized Modem Link

## Sample Definition of LPDA-1 Nontailed Modems

Figure 23-3 illustrates LPDA-1 nontailed modems on SDLC or BSC links.

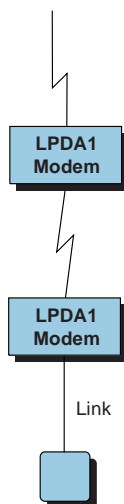

Figure 23-3. LPDA-1 Nontailed Modems on SDLC or BSC Links

Figure 23-4 shows how to code LPDA-1 nontailed telecommunication lines.

```
LINK1   LINE  SPEED=9600,  
        LPDATS=LPDA1,      LPDA supported in migration mode  
        .  
        .  
        .
```

Figure 23-4. Example: Defining an LPDA-1 Nontailed Telecommunication Link

## Normal Mode (LPDA-2)

NCP runs LPDA-2 tests in response to NMVT solicited requests from the NetView program or LPDA-2 unsolicited requests, such as an error condition or a statistical event.

NCP supports LPDA-2 tests on lines connected to any modem port. However, the LPDA-2 channelized modems can detect an LPDA command only on port A; therefore, LPDA-2 test requests for ports B, C, or D are routed through port A, which acts as the service port for lines on the other ports. An indicator in the LPDA-2 command frame tells the modem which line is associated with the LPDA-2 test.

If you define a line that is not on port A as LPDATS=LPDA2, you must also define the port A line for that modem as LPDATS=LPDA2.

Code the following definition statement and keywords to provide NCP with information about LPDA-2 tests.

LINE	CHANLA CHNLZ CORNUM DATRATE PORT TAILING
------	---

CHANLA on the LINE definition statement specifies whether the line is attached to port A, the LPDA control channel of the modem.

**Note:** If NCP performs LPDA-2 tests for the first or only link segment of a line that is not on port A, these tests are routed to the line connected to port A of the modem.

CHNLZ defines an attachment to a channelized modem. If you specify CHNLZ=YES, do not use X'FD' or X'FF' for the station address of an SDLC device, or as the first character of the polling or addressing sequence for a BSC device.

CORNUM defines a 2-byte correlation number for all the lines attached to a particular channelized modem. A maximum of four lines can have the same correlation number in your NCP generation. Each data multiplex modem must have a unique CORNUM. A maximum of four links can have the same CORNUM. You cannot code lines with the same CORNUM as LPDA-1 and LPDA-2.

**Note:** Lines with different protocols (such as SDLC, BSC, or start-stop) can share the same channelized modem. For start-stop lines, LPDA-2 is not supported. However, if you specify LPDATS=NO, you can code the CHNLZ and CORNUM keywords.

If you use a channelized modem, all lines must be attached either directly to the IBM 3745 or to the 3746 Model 900. You may not use a combination of 3746 Model 900 and IBM 3745-attached lines.

DATRATE specifies a high or low data rate for a dual-rate modem.

PORT identifies the modem channel to which a BSC or SDLC line is attached. You can code this keyword only if LPDATS=LPDA2 and CHNLZ=YES. Specify PORT as A, B, C, or D.

TAILING defines whether a second-level LPDA circuit (second link segment) is attached to the link. If you specify TAILING=YES, do not use X'FD' or X'FF' for the station address of an SDLC device, or as the first character of the polling or addressing sequence for a BSC device.

If multiple channels of a remote modem are shared by the same multipoint line (associated in fan-out mode), a tailed link segment can be attached to only one of the shared channels.

For unsolicited tests on a tailed link with the station or resource on link segment 1, NCP performs LPDA-2 tests only on link segment 1.

### Sample Definition of LPDA-2 Nontailed and Nonchannelized Links

Figure 23-5 shows a nontailed, nonchannelized LPDA-2 link.

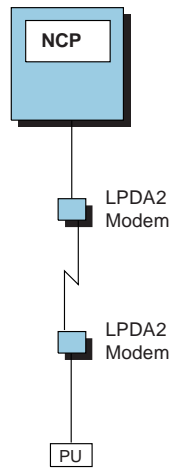

Figure 23-5. LPDA-2 Nontailed, Nonchannelized Link

Figure 23-6 shows how to code the LPDA-2 link shown in Figure 23-5.

LINK1	LINE	LPDATS=LPDA2,	LPDA supported in normal mode
		.	
		.	
		.	

Figure 23-6. Example: Defining an LPDA-2 Nontailed, Nonchannelized Link

**Sample Definition of LPDA-2 Tailed and Nonchannelized Links**

If the link is tailed and the station or resource is on link segment 2, NCP performs unsolicited LPDA-2 tests on both link segments. Figure 23-7 shows a tailed, nonchannelized LPDA-2 link with one physical unit on link segment 1 and one physical unit on link segment 2.

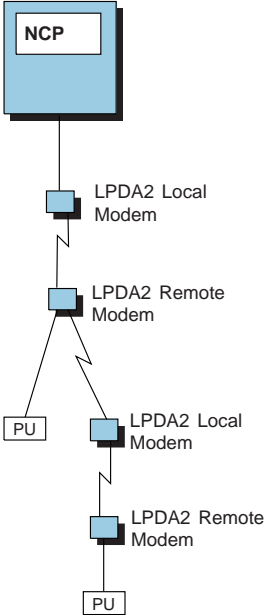

Figure 23-7. LPDA-2 Tailed, Nonchannelized Link

Figure 23-8 shows how to code the LPDA-2 link shown in Figure 23-7.

LINK1	LINE	LPDATS=LPDA2, TAILING=YES, .	LPDA supported in normal mode 2nd link segment attached (tailed)
		.	
		.	
*			
PU1	PU	SEGMENT=1	PU is on 1st link segment
*			
PU2	PU	SEGMENT=2	PU is on 2nd link segment

Figure 23-8. Example: Defining an LPDA-2 Tailed, Nonchannelized Link

### Sample Definition of a Full Data Multiplex Configuration

Figure 23-9 shows a full data multiplex configuration with four channelized links attached to the same modem pair. One link is defined as start-stop, one is SDLC LPDA-2, and the other two are defined as BSC LDPA-2.

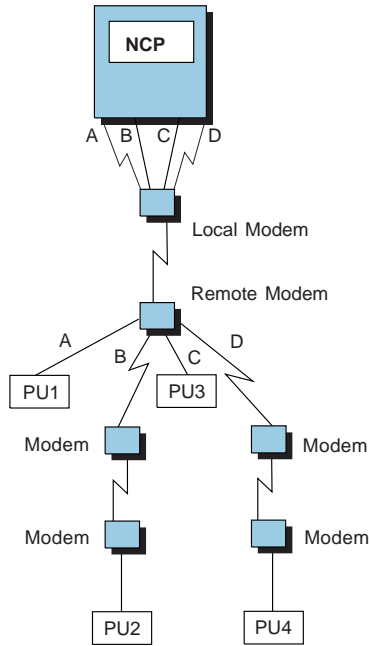

Figure 23-9. Full Data Multiplex Configuration

Figure 23-10 shows how to define the full data multiplex configuration shown in Figure 23-9 on page 23-14.

```

BSC      GROUP  LNCTL=BSC      BSC line group
*
LINKA    LINE   CHNLZ=YES,    Attached to channelized modem
          TAILING=NO,
          PORT=A,          Channel A
          CHANLA=YES,     YES is default when PORT=A
          CORNUM=24,      Correlation number for this modem
          LPDATS=LPDA2    LPDA supported in normal mode
*
PU1      CLUSTER SEGMENT=1
*
LINKC    LINE   CHNLZ=YES,    Attached to channelized modem
          TAILING=NO,
          PORT=C,          Channel C
          CHANLA=NO,     NO is default when PORT=A
          CORNUM=24,      Correlation number for this modem
          LPDATS=LPDA2    LPDA supported in normal mode
*
PU3      CLUSTER SEGMENT=1
*
SS       GROUP  LNCTL=SS      Start-stop line group
*
LINKB    LINE   CHNLZ=YES,    Attached to channelized modem
          CORNUM=24,      Correlation number for this modem
          LPDATS=NO      LPDA not supported for this line
*
SDLC     GROUP  LNCTL=SDLC    SDLC line group
*
LINKD    LINE   CHNLZ=YES,    Attached to channelized modem
          TAILING=YES,    2nd link segment attached (tailed)
          PORT=D,          Channel D
          CHANLA=NO,     NO is default when PORT=A
          CORNUM=24,      Correlation number for this modem
          LPDATS=LPDA2    LPDA supported in normal mode
*
PU4      PU     SEGMENT=2     PU is on 2nd link segment
    
```

Figure 23-10. Example: Defining a Full Data Multiplex Configuration

### Switched Telecommunication Links

Code the following definition statement and keyword to provide NCP with information about diagnostic aids for switched telecommunication links.

```

LINE      ANSTONE
          AUTO
          LPDA2DL
          RING
    
```

ANSTONE on the LINE definition statement specifies whether NCP sends an answer tone to the calling device to signify completion of the link connection. Most modems in the United States and Canada provide this answer tone; therefore, you do not usually have to specify that NCP send it. If you are not sure that your

## Link Problem Determination Aid

modem provides this tone, ask the supplier or installer of the modem. Code ANSTONE for a link that can only receive calls from devices attached to the link.

AUTO identifies the relative line number of an automatic calling unit.

**3746 Model 900 SDLC Lines:** Code AUTO=YES or AUTO=NONE. Do not code a line number on the AUTO keyword.

LPDA2DL identifies an SDLC or BSC line that is attached to a modem that can support the LPDA-2 modem dial facility, even if it is not an LPDA-2 modem. This type of modem, such as an IBM 4941 modem, can accept LPDA dial and disconnect commands.

**3746 Model 900 SDLC Lines:** LPDA2DL is invalid.

RING specifies whether the modem has the ring-indicator interface. If you are not sure if your modem has this feature, ask the supplier or installer of the modem. Defining this feature for a modem that does not have it can result in an unnecessary delay in establishing the connection. Also, outgoing calls cannot be made if you specify that the modem has this feature.

**Note:** RING does not apply to networks in the United States or Canada.

## Multiple Local Modem Support

Multiple local modem support enables NCP to perform LPDA-2 tests on lines with several local modems on either the first or second link segment. Figure 23-11 on page 23-17 shows multiple local modems that exist on both link segments.

Code the following definition statement and keyword to provide NCP with information about how to test lines with multiple local modems on each link segment.

PU	LMODADR SEGMENT
CLUSTER	LMODADR SEGMENT
TERMINAL	LMODADR SEGMENT

LMODADR on the PU, CLUSTER, and TERMINAL definition statements specifies the local modem addresses on each link segment when multiple local modems are on one line.

SEGMENT indicates whether a station or resource resides on the first or second link segment. The network problem determination application (NPDA) uses this information to establish solicited LPDA-2 tests.



### Sample Definition of Local Modem Addresses

Figure 23-11 shows integrated digital network exchanges with local modems attached to the first and second segments.

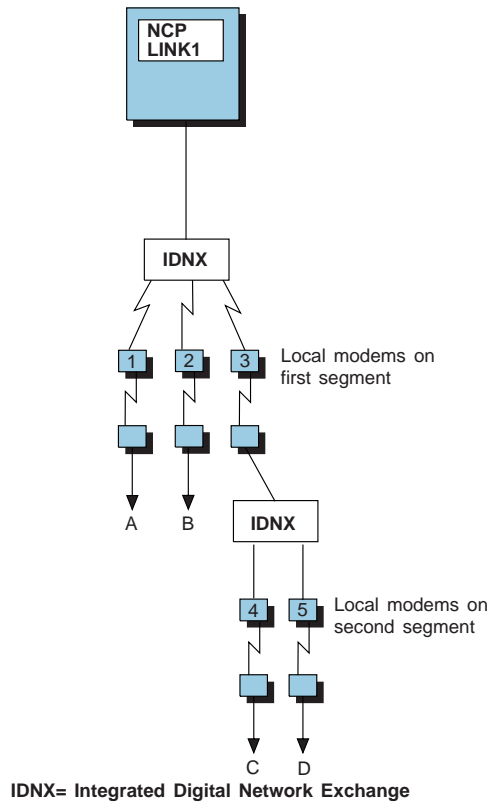

Figure 23-11. Multiple Local Modems

Figure 23-12 shows how to define the addresses for physical units A, B, C, and D, which are attached to integrated digital network exchanges shown in Figure 23-11. The first 4 bits are a unique modem identifier and the last 4 bits represent the segment on which the modem resides.

UNITA	PU	LMODADR=(11)	Local modem address (11)
*			
UNITB	PU	LMODADR=(21)	Local modem address (21)
*			
UNITC	PU	LMODADR=(31,42)	Local modem address 2-links (31,42)
*			
UNITD	PU	LMODADR=(31,52)	Local modem address 2-links (31,52)

Figure 23-12. Example: Defining Local Modem Addresses

---

### Monitoring Virtual Route Congestion

NCP enables you to monitor virtual routes to show potential problem areas and to tune the virtual route to avoid congestion. You can specify two time-limit values and a maximum queue size for a virtual route. When these limits are exceeded, a generic alert is sent for a blocked virtual route.

Code the following definition statements and keywords to provide NCP with information about virtual route monitoring, congestion thresholds, and timeout values.

BUILD	VRTIMER $n$
NETWORK	VRTIMER $n$

VRTIMER $n$  can be coded on the BUILD or NETWORK definition statement to specify the parameters that generate generic alerts for congested or blocked virtual routes and the deactivation of held virtual routes.  $n$  represents the transmission priority (0, 1, or 2) of the virtual route to which this set of parameters applies. VRTIMER specifies the length of time that a virtual route can be congested before NCP sends an alert, the length of time that a congested virtual route can be held before NCP deactivates the virtual route and sends an alert, and the inbound PIU congestion threshold.

Congestion data is collected and sent by NCP to the NetView program. The NetView program makes congestion information and virtual route status available for display and analysis by the network operator. See *NCP and EP Reference* for more information about what NCP considers to be a congested or blocked virtual route.

---

### Deactivating an Out-of-Sequence Virtual Route

Beginning with NCP V7R6, code the VOSDEACT keyword on the BUILD statement to cause NCP to initiate VR deactivation when a VR goes out-of-sequence.

---

### Monitoring Transmission Group Performance

NCP enables you to monitor transmission groups to show, and optionally deactivate, any TGs that are experiencing flow control problems. You can specify two time-limit values. When a TG is hung<sup>1</sup> longer than the first time limit, NCP sends an MLTG performance degradation alert, also known as a hung-TG alert. When an MLTG is hung longer than the second time limit, NCP deactivates the MLTG.

Code the following definition statements and keywords to provide NCP with information about MLTG performance monitoring.

---

<sup>1</sup> Refer to *NCP, SSP, and EP Diagnosis Guide* for more information about what NCP considers to be a hung TG.

BUILD	TGTIMER
NETWORK	TGTIMER

TGTIMER can be coded on the BUILD or NETWORK definition statement.

---

## Monitoring for Excessive Buffer Usage by a Peripheral Resource

Use the QSZALERT keyword to have NCP alert the network operator when any peripheral resource is using an excessive number of NCP buffers.

BUILD	QSZALERT <sup>1</sup>
-------	-----------------------

<sup>1</sup>Supported starting with NCP V7R6.

QSZALERT specifies a buffer utilization threshold (*threshold\_1%*) at which NCP will begin examining sessions and stations to determine whether a session or station is using an excessive number of buffers as defined by a second parameter (*threshold\_2%*). In addition, a third parameter (*action*) enables you to specify whether NCP should deactivate the session or station that is overusing the buffers.



---

## Chapter 24. Network Performance

Several NCP characteristics, as well as the relationship between NCP and its attached resources, affect the performance of the network. This chapter describes these characteristics, and the definition statements and keywords you can use to enhance network performance.

In most cases, it is difficult to determine how your network performs until all the resources are installed and fully operational. Therefore, you might need to adjust the values you code for these keywords after you have observed your network in operation.

**NTuneMON:** You can use NTuneMON to determine the current status and usage of many NCP resources, and you can use NTuneNCP to enhance NCP performance by adjusting various NCP parameters while NCP is running. In addition, you can use NTuneMON to change certain characteristics of the line as long as the line is inactive.

For a list of keywords that you can tune, see Chapter 5 of the *NTuneMON User's Guide*.

### Where to Find More Information

Following are additional sources of information for tuning your network:

- The performance and storage models contained in the 3745 configurator on HONE and available via IBMLINK.
- *NCP V7R8 Migration Guide*.
- Ask your IBM contact to get NCPPERF PACKAGE from the MKTTOOLS disk.

---

## Defining NCP Buffer Size

Optimum buffer size enables NCP to attain peak performance. This section describes the definition statements and keywords you need to define buffers, control the flow of data, and optimize communication with NCP resources. For information about network flow control, See *NCP and EP Reference*.

Code the following definition statements and keywords to provide NCP with information about how to define NCP buffer size to make optimum use of system resources and improve the flow of data.

BUILD	BFRS
LINE	TRANSFR

BFRS on the BUILD definition statement defines the size of the buffers in the NCP buffer pool. Buffers from this pool contain PIU messages from access methods in channel-attached host processors, other NCPs, and link-attached devices. Code a BFRS value that is a multiple of four to provide fullword alignment.

## Defining NCP Buffer Size

Buffer initialization occurs immediately after NCP is loaded into the communication controller. During this process, NCP formats all remaining controller storage space into buffers. This space is divided by the rounded buffer size, plus a 12-byte buffer management prefix, to yield the number of buffers in the pool. The 12-byte buffer management prefix is used to chain buffers together and hold the data count and data offset of the data within the buffer.

Take the following factors into consideration when you estimate BFRS:

- The size of messages and control fields used in the network. Short messages require only a portion of a single buffer. Therefore, if you use short messages and specify a small buffer size, less unused buffer space exists. This unused space can be used elsewhere for other PIU traffic. Long messages, on the other hand, require multiple buffers, which means chaining several buffers to contain a single long message.
- The maximum size of data sent to an SDLC device as a segment. Define this size for MAXDATA on the PU definition statement. See the description on page 24-8.
- The required command and response PIUs. Response PIUs can represent a significant amount of traffic, especially when an NCP operates in a definite response mode, where 50% of all traffic could be responses or where pacing responses are used.
- Multiple buffer PIUs. Use a large NCP buffer size to improve performance when multiple buffer PIUs are transferred across channels.
- The diagnostic programs that communicate with NCP through the access method. See the appropriate manuals for such diagnostic programs to determine what, if any, restrictions apply.

If you include emulation functions for any BSC or start-stop devices attached to NCP or EP, BFRS also specifies the number of buffers allocated for the free buffer pool. An NCP operating in emulation mode or EP uses the free buffer pool to communicate with MOSS in the controller.

TRANSFR on the LINE definition statement determines the maximum length PIU the channel adapter will accept. TRANSFR can limit the amount of data accepted from a channel link during one data transfer to no more than the access method in the destination host processor (and intermediate access methods, if any) can accept in a single channel operation or to no more than the data transfer limit imposed by a subsequent NCP in the path. TRANSFR also limits the number of buffers NCP can assign at one time, thus preventing the channel adapter from monopolizing the available NCP buffers.

If you do not code TRANSFR on the LINE definition statement, NDF uses the value you defined for TRANSFR on the BUILD definition statement or its default. See *NCP and EP Reference* for information about how to define the maximum and minimum values of TRANSFR.

**Note:** The TRANSFR value must be the same for all lines in the transmission group. Otherwise, problems with link activation result.

VTAM: The TRANSFR value multiplied by the BFRS value, minus 18, must match the value of MAXDATA on the PCCU definition statement.

## Reaching the Buffer Limit

NCP procedures differ for SDLC, BSC, start-stop, and channel adapter links when the buffer limit for the link is reached.

For an SDLC link, if NCP does not receive the end of the PIU by the time the buffer limit is reached, it discards all of the data received. NCP also sends an SDLC *next receive count error* to the sending device. The data is retransmitted until an error threshold is reached and the physical unit is taken out of service with a permanent error. The discarded data is not sent to the access method.

For a BSC or start-stop link, NCP sends the filled buffers to the access method as a subblock and continues to receive data from the device until it receives an end-of-block or end-of-transmission character, or until the subblock limit you code for CUTOFF on the LINE definition statement is reached.

For a channel adapter link, when the transfer limit is reached NCP initiates a data check which terminates the data transfer from the host. NCP discards all of the data received; the discarded data is not sent to the access method.

---

## Data Flow Control

Code the following definition statement and keywords to provide NCP with information about the optimum number of buffers needed to avoid congestion.

BUILD	CWALL
	SLODOWN

CWALL on the BUILD definition statement defines the number of buffers your NCP reserves for control data originating in an access method to flow through NCP. When the number of buffers is exhausted, NCP accepts no more data until additional buffers are available.

SLODOWN defines the slowdown entry threshold for NCP buffers. This number represents a percentage of NCP buffers that must be available for normal processing. When the percentage of available buffers drops below this threshold, NCP reduces the amount of data it accepts from the network control subchannel and from telecommunication links operating in network control mode. NCP continues to send data over the subchannel and links to reduce the number of buffers in use. When the buffer supply exceeds the SLOWDOWN threshold again, NCP automatically resumes normal operation.

If the value of SLODOWN (when converted from the percentage of NCP buffers available before slowdown to the actual number of buffers available) is less than the value of CWALL plus 74, CWALL plus 74 is used as the slowdown entry threshold.

During initialization, NCP abends unless the total number of buffers contained in NCP is double the slowdown entry threshold. For example, if you use the default of 26 for CWALL, NCP abends during initialization if the total number of buffers is less than 200  $((26 + 74) \times 2)$ . These 200 buffers are not enough to guarantee satisfactory performance or prevention of deadlock. The actual number of buffers required depends on the dynamic operation of the system.

---

### Timeout Values

Code the following definition statements and keywords to provide NCP with information about how to define the elapsed time before an error condition occurs.

GROUP	REPLYTO
	TEXTTO

REPLYTO on the GROUP definition statement determines reply timeout values for the telecommunication links in the group. If NCP does not receive a response to a poll, selection, or frames before the defined time expires, a timeout error is generated, and the appropriate error recovery procedure is initiated.

If you define a GROUP definition statement for a subarea link or group of subarea links connecting two NCPs, there is a minimum reply value used when the loading or dumping of a link-attached NCP occurs over these links. See *NCP, SSP, and EP Resource Definition Reference* for these minimum values. Reply timeouts for BSC devices using conversational replies must be long enough to permit the conversational text to be received. When you define a subarea link, the REPLYTO value for the primary NCP should be longer than the PAUSE value for the secondary NCP.

On switched SDLC lines, the XMITDLY interval defined on the GROUP statement is used as the reply timeout value while XIDs are exchanged. In other cases, the REPLYTO value is used.

TEXTTO specifies a text timeout value for the telecommunication links in the group. If the interval between any two successive message characters received from a device exceeds the value you specify for TEXTTO, NCP ends the read or invite operation with a text timeout error indication. For SDLC links, the timeout occurs when the link station in this NCP is the primary link station and when the link is in network control mode. For BSC links, the timeout occurs only when the link is in network control mode. For start-stop links, the timeout occurs whether the link is operating in network control mode or emulation mode.

---

### Service Order Table

Code the following definition statements and keywords to provide NCP with information about how to define the service order table (SOT) that determines the assigned order of device activation.

SERVICE	ORDER
LINE	SERVLIM

ORDER on the SERVICE definition statement establishes the order in which NCP services the devices attached to a telecommunication link. If you omit ORDER or the SERVICE definition statement, NDF automatically generates the SOT for a line operating in network control mode.



For a BSC or start-stop link, each individually polled and addressed device represented by a TERMINAL or COMP definition statement (or by a CLUSTER definition statement on which GPOLL is coded) must be represented by at least one entry on the ORDER keyword. The generation procedure checks entries in the SOT to determine whether the devices represented by CLUSTER, TERMINAL, COMP, or PU definition statements are associated with the telecommunication link that the SOT represents. The generation procedure also checks whether each of these devices is represented in the SOT.

**3746 Model 900 SDLC Lines:** For 3746 Model 900 SDLC lines, ORDER determines the relative frequency at which the devices are polled, but not the polling order. For example, if you code ORDER=(A,B,A,C), the 3746 Model 900 polls device A twice as often as B or C, though not necessarily in that order.

SERVLIM on the LINE definition statement determines how often NCP will check the SOT. Upon completing a regular scan, NCP begins the special scan if it finds no active devices in the regular scan just completed or if the maximum number of regular scans specified for SERVLIM is reached.

**Notes:**

1. For BSC and start-stop telecommunication links, SERVLIM specifies the number of entries NCP checks in the SOT each time it performs service seeking for the BSC or start-stop links. If you do not code SERVLIM, NCP checks half of the table entries each time it does service seeking. For a BSC link, if NCP found no devices in the contacted state in the previous regular scan, it resumes regular scans after a delay of 0.2 seconds.
2. For SDLC telecommunication links, SERVLIM determines how often NCP interrupts its regular scans of the service order table, during normal servicing of SDLC devices attached to the link, to make a special scan of the table. Use SERVLIM to specify one of the following limits:
  - Maximum number of regular scans before NCP performs a special scan
  - Minimum time elapsed between special scans.

A regular scan of the table accommodates normal transmission of PIUs between the access method or host processor application programs and SDLC devices or logical units attached to the link.

In a special scan of the SOT, NCP determines whether there are any outstanding commands from the access method to interrogate or alter the online status of any SDLC devices on the link. If so, NCP fulfills the first such command and then resumes regular scans of the table to perform normal servicing. If no stations require service during the special scan and no stations had required service during the preceding regular scan, a regular scan resumes after a delay of 2.2 seconds. If more than one status command is outstanding, NCP honors only one each time the special scan is made; it fulfills the remaining status commands one at a time, in turn, during subsequent special scans of the table.

---

### Defining Session Pacing

You can choose fixed session pacing or adaptive session pacing. Fixed pacing specifies a particular number of requests that the logical unit can send before a response is required. Adaptive pacing causes an algorithm to vary the window size depending on the transmission load. Adaptive session pacing is the default.

Code the following definition statements and keywords to provide NCP with information about the flow of transmitted data (pacing).

BUILD	ADPLIMIT
LU	PACING

#### BUILD

ADPLIMIT on the BUILD definition statement specifies the maximum window size that NCP sets in an adaptive pacing response message (IPM).

#### LU

PACING on the LU definition statement defines the number of PIUs a logical unit is to send to NCP before transmission stops to await a pacing response from NCP. The pacing response indicates that NCP has received the data sent by the logical unit and that it is ready to accept more data.

Consider the following points when coding PACING:

- If you do not want pacing controlled by session parameters, as defined by logical unit session-initiation procedures and access method tables, specify 0 in the BIND command and use PACING to specify the required pacing value. The default value might be suitable in this case. Note that if you specify a nonzero value in the BIND command, that value overrides the value you code for PACING.
- If you do not code PACING or if you specify PACING=0, NCP uses an adaptive algorithm for the window size.

Restrictions might be placed on the value you choose for PACING depending on the types of devices connected to your NCP. See the appropriate programming publications for the types of devices attached to your NCP for such restrictions.

---

## Data Transfer

Code the following definition statements and keywords to provide NCP with information about the data transfer process and how to limit line trace data.

BUILD	TRCPIU
LINE	CUTOFF TRANSFR
PU	BLOCK DATMODE MAXDATA MAXOUT PASSLIM PIUCHECK <sup>1</sup> XID
<sup>1</sup> Supported starting with NCP V7R7	

## BUILD

TRCPIU on the BUILD definition statement limits the amount of line trace data accumulated in NCP buffers to no more than the access method in the destination host processor (and intermediate access methods, if any) can accept in a single PIU. TRCPIU also limits the amount of line trace data to no more than the data transfer limit imposed by a subsequent NCP in the path. The path between NCP and the destination host processor can comprise a channel connection to the attached host processor or a combination of SDLC links between NCPs and a channel connection to a distant host processor.

When NCP fills the specified number of buffers with line trace data, it transfers the data to the destination host processor and continues to collect trace data in other buffers. The cycle of obtaining buffers, filling them, and transferring their contents to the host processor continues until the operator ends the line trace.

## LINE

CUTOFF on the LINE definition statement specifies the maximum number of subblocks NCP accepts from a BSC or start-stop device attached to a telecommunication link. A subblock is the sequence of message text occupying the number of buffers you code for TRANSFR on the LINE definition statement. If NCP receives the number of subblocks you define for CUTOFF before receiving an end-of-block character from the device, it stops transmission. Otherwise, it continues to accept data from the device until it receives an end-of-block character. If any subblock contains an error (indicated by a bit in the response header for the subblock), the application program normally discards all of the subblocks in the block, not only the one in error. There is no provision for requesting retransmission of subblocks in error.

TRANSFR defines the maximum number of buffers necessary to contain the maximum amount of data that NCP can receive in a single data transfer operation. If you are defining a channel adapter, it determines the maximum length PIU that the channel adapter will accept in a single data transfer operation.

## PU

BLOCK on the PU definition statement improves the performance of type 4 physical units attached to nonswitched telecommunication links. NCP can support multiple PIUs in SDLC frames when they are routed over transmission group links. This results in fewer interframe gaps in a transmission than the number of interframe

gaps that would have occurred if the sender transmitted the PIUs in individual frames. BLOCK specifies the maximum frame size and the maximum number of PIUs per frame. If you code BLOCK, NCP verifies whether or not the sender of the format 2 XID exchange supports PIU blocking. If not, NCP uses one frame for each PIU. If the format 2 XID exchange supports a smaller block size, NCP adjusts its block size to the XID value.

DATMODE specifies whether NCP communicates with the device in half-duplex or duplex mode. Code DATMODE if an SDLC device attached to a switched or non-switched telecommunication link transfers data in duplex mode, as specified by the ADDRESS keyword on the LINE definition statement. Duplex data mode is available for both switched and nonswitched lines. Code duplex if the device sends and receives data at the same time on a duplex link. Code half-duplex if the device either sends or receives at any one time. Note that although devices attached to a duplex link may only be capable of half-duplex data transfer, NCP can send to one device over the telecommunication link and at the same time receive from another. If separate transmitting and receiving paths are available, an NCP in a channel-attached controller operates the subarea link to an adjacent NCP in duplex data mode, unless you specify half-duplex mode for DATMODE on the PU statement representing the link-attached NCP.

**Note:** Type 2.1 physical units create a value for DATMODE in their format 3 XID exchange; therefore, you do not need to code a value for DATMODE.

MAXDATA specifies the maximum amount of data the device sends or receives in one data transfer, that is, in one PIU or PIU segment (including the transmission header and request/response header). Code MAXDATA if a type 1 or type 2 SDLC physical unit attaches to a nonswitched telecommunication link. See the publication for each device to determine the amount of data it can receive. The maximum amount of user data NCP sends to the device is the MAXDATA value minus the number of bytes required for transmission header data.

**Note:** If you define a type 2.1 physical unit, MAXDATA is not required. Type 2.1 physical units create a value for MAXDATA in their format 3 XID exchange.

Restrictions can be placed on the value of MAXDATA depending on the types of SDLC devices attached to NCP. See the appropriate programming publications for such restrictions on the types of devices attached to NCP.

MAXOUT specifies the maximum number of frames NCP sends to a type 1 or type 2 SDLC physical unit before an SDLC response from the device is required. For a type 4 physical unit, MAXOUT specifies the maximum number of frames NCP receives from the SDLC device before an SDLC response is required. A higher MAXOUT value improves link performance; however, a higher value also causes more PIU retransmissions if an error occurs. You might want to select a lower value for links with high error rates and a higher value for links with low error rates.

**Note:** Restrictions can be placed on the value of MAXOUT depending on the types of SDLC devices attached to NCP and on the mode (modulo 8 or modulo 128) selected for the link. See the appropriate programming publications for the types of devices attached to your NCP for such restrictions.

MAXOUT is not required if you define a type 2.1 physical unit; during a type 2.1 physical units' activation sequence, a format 3 XID exchange is performed. For these physical units, the value coded for MAXOUT is used during the format 3 XID exchange to:

- Specify the maximum number of information frames that NCP is to receive from the adjacent link station before a response is required.
- Specify the maximum number of information frames that NCP is to send before NCP requires a response from the adjacent link station. The operational maximum used by NCP may be less than the value coded for MAXOUT, because NCP will use the smaller of the values coded for MAXOUT and the value contained in the format 3 XID received from the adjacent link station.

PASSLIM defines the maximum number of consecutive PIUs NCP is to send at one time to a device. When the PASSLIM value is reached, NCP services the next entry in the SOT. Code PASSLIM if an SDLC device is connected to a non-switched telecommunication link.

PASSLIM is not required if you define a type 2.1 physical unit. Type 2.1 physical units create a value for PASSLIM in their format 3 XID exchange; however, NCP can adjust the value of PASSLIM to control the maximum number of consecutive PIUs it sends at one time to the type 2.1 physical unit. NCP uses the smaller of the XID generated value for MAXOUT or the XID generated value for PASSLIM.

PIUCHECK specifies whether a checksum validation should be performed on PIUs sent and received by this subarea station. For the checksum validation support to be enabled, the adjacent link station must also have PIUCHECK=YES coded.

**Technical Notes about PIUCHECK Support:** PIUCHECK support is provided for both 3745 and 3746 Model 900 attached subarea stations with the following protocols:

- Frame relay
- ISDN
- SDLC
- Token Ring

For a multilink transmission group (MLTG), the PIUCHECK support is negotiated between each pair of stations, and the support need not be consistent across all station pairs in an MLTG. For example, one pair of stations can use the PIUCHECK support, and a second pair of stations in the same MLTG can operate without the PIUCHECK support.

When subarea checksum support is enabled via PIUCHECK, the transmitting node computes a simple 2-byte checksum based on the first part of a PIU. For performance reasons, a checksum of the entire PIU is not practical, so the checksum is the sum of the first 17 halfwords. When a PIU is less than 34 bytes, the PIU is padded to the right with zeros for the checksum computation. Performing the checksum on the first 34 bytes of the PIU provides protection for:

- FID\_4 (FID\_F) transmission header (TH) — 26 bytes
- Request/response header (RH) — 3 bytes (if present)
- Request/response unit (RU)
  - If RH present, 5 bytes maximum
  - If RH not present, 8 bytes maximum

When multiple PIUs are included in a single frame, each PIU includes a checksum.

## Timeouts

The receiving node compares the checksum from the received PIU with the computed checksum. If a mismatch occurs, the frame is discarded, causing a retransmission.

**Note:** PIUCHECK support increases the pathlength required for NCP to send or receive a PIU, so PIUCHECK support should be used only when the additional protection is required.

XID defines a physical unit's ability to receive and respond to an XID exchange while in normal disconnected mode (NDM). This keyword controls the use of XID during initial CONTACT processing. There may be devices designed for non-switched line operation that cannot accept an XID since XID is an optional function for SDLC communication.

Code XID=NO if you define a type 2 physical unit device.

---

## Timeouts

Code the following definition statements and keywords to provide NCP with information about the dialing process and how long it is to wait when data is sent over switched lines.

BUILD	DIALTO DSABLTO ENABLTO ITEXTTO
GROUP	TTDCNT WACKCNT WAKDLAY
LINE	NEGPOLP PAUSE POLLTO SERVPRI

### BUILD

DIALTO on the BUILD definition statement defines the timeout value NCP uses to detect the failure of an automatic calling unit's abandon-call-and-retry (ACR) signal. Code DIALTO when you define a switched telecommunication link.

DSABLTO specifies the timeout value used to detect a failure of the modem data-set-ready signal lead. The disable operation is started by turning off the modem data-terminal- ready lead and then waiting the amount of time specified by DSABLTO for data-set-ready to turn off. If data-set-ready fails to turn off, an error will be posted, and the link will still be disabled.

ENABLTO specifies the timeout value NCP uses to detect the failure of the data-set-ready signal line of a modem which is turned on when the telecommunication link connected to the modem is enabled (for nonswitched links), or when a dialing operation is complete (for switched links). This timeout also monitors for clear-to-send (CTS) after raising request-to-send (RTS) when starting transmit operations.

This interval may take longer for switched lines. Consult your modem characteristics for more information.

Choose a timeout value carefully because this value can affect NCP performance. The timeout should be long enough to permit connections through dial-up lines, but not so long that line deactivation is inhibited when a shutdown is initiated. For example, a longer timeout is necessary if you define a channel-attached NCP that includes switched backup SDLC links connected to a link-attached controller. The enable timeout must be long enough to permit the system operator to (1) dial the telephone number, (2) receive an answer, and (3) place the modem (data set) in data mode. Typically, this process can take from 30 seconds to more than a minute.

ITEXTTO specifies a text timeout for any terminal or component defined with INHIBIT=TEXTTO on the TERMINAL or COMP definition statement.

## GROUP

TTDCNT on the GROUP definition statement determines the maximum number of times NCP accepts the temporary text-delay (TTD) sequence from a BSC device attached to any of the telecommunication links in this group before NCP aborts the operation. The TTD sequence notifies NCP that the device is temporarily unable to send the next block of data.

WACKCNT defines the number of times NCP accepts a wait-before-transmit positive acknowledgment (WACK) from a BSC device attached to any of the telecommunication links in this group before NCP aborts the operation. The WACK sequence notifies NCP that the device is temporarily not ready to receive. WACKCNT has no effect on buffered devices because NCP, upon receiving a WACK sequence from such a device, sends an EOT to end the transmission.

WAKDLAY defines how many seconds NCP waits before responding to message text received from a BSC device attached to any of the telecommunication links in the group. If NCP is unable to respond with a positive acknowledgment by the specified time, it sends a WACK sequence instead.

## LINE

NEGPOLP on the LINE definition statement defines how many seconds NCP pauses after receiving a negative response to polling from a BSC device before it resumes a polling operation. A negligible polling pause improves the efficiency of polling on the link, while a long polling pause increases the response time of the devices attached to the link.

PAUSE defines how many seconds of delay exist between successive polling cycles. If a pause occurs when activity on a link is relatively low, it can reduce the amount of processing time that unproductive polling uses. A large number of active entries in the SOT increases the likelihood that polling cycles will proceed continuously without intervening pauses. When you generate subarea links, the REPLYTO value in the primary NCP should be longer than the PAUSE value in the secondary NCP. For large subarea configurations, the PAUSE value for the secondary state should be at least 0.5 seconds.

## Initially Inhibiting NCP Functions

### Notes:

1. For BSC and Start-Stop Telecommunication Links, code PAUSE only if the devices attached to the BSC or start-stop link must be polled and addressed. PAUSE specifies the delay between successive polling cycles when no sessions currently exist. If you do not code PAUSE, there is no delay between successive cycles. When at least one new session is established, the pause is inoperative, because to observe it would delay session servicing.
2. For SDLC Telecommunication Links, PAUSE specifies the average duration of the polling cycle. The polling cycle extends from the moment NCP examines the first entry in the SOT to the moment polling next begins in the same entry. It includes time for polling, reading from, and writing to the devices on the link. If the time expended in a complete polling cycle (servicing all active entries in the SOT) equals or exceeds the PAUSE value, the next polling cycle begins immediately. If the time expended in a complete polling cycle is less than the PAUSE value, the beginning of the next polling cycle is delayed until the PAUSE time has elapsed. During a pause, the link is in poll-wait state; any outgoing data ready for transmission to the SDLC devices on the link is sent during this pause.

POLLTO defines whether NCP treats a timeout occurring during polling as an error condition or as a negative response. If you decide that you want it treated as an error condition, the value you specify for CRETRY on the GROUP definition statement determines the number of subsequent attempts NCP makes at polling the start-stop devices attached to the link. If you choose to have the timeout treated as a negative response, the value you code for POLIMIT on the LINE definition statement for the link determines the number of times NCP repolls the devices attached to the link.

SERVPRI determines whether NCP gives priority to servicing current sessions on the link or to establishing new sessions on the link. Code SERVPRI when you define a multipoint BSC or start-stop telecommunication link.

---

## Initially Inhibiting NCP Functions

Code the following definition statements and keywords to provide NCP with information about functions that are initially inhibited.

CLUSTER	INHIBIT
TERMINAL	INHIBIT
COMP	INHIBIT

### CLUSTER

INHIBIT on the CLUSTER definition statement specifies which NCP functions will not be enabled for a BSC clustered station when NCP is activated in the controller. The functions that can be initially inhibited are:

- The WACK limit defined by WACKCNT on the GROUP definition statement. If you initially inhibit this limit, the first WACK received from the station causes



NCP to return the request to the access method rather than respond to that and subsequent WACKs with an ENQ character.

- The subblocking specified by TRANSFR on the LINE definition statement. If you initially inhibit subblocking, when the number of buffers defined for TRANSFR is filled by received text, NCP terminates the receive operation just as if the cutoff limit defined by CUTOFF on the LINE statement were reached.
- The recovery procedures for text-read errors specified by RETRIES on the LINE statement. If you initially inhibit these procedures, NCP does not attempt recovery for text-read errors.
- The recovery procedures for text-write errors defined by RETRIES on the LINE statement. If you initially inhibit these procedures, NCP does not attempt recovery for text-write errors.

### TERMINAL

INHIBIT on the TERMINAL definition statement specifies which NCP functions will not be enabled for a BSC or start-stop device when NCP is activated in the controller. The functions that can be initially inhibited are:

- The text timeout value coded for TEXTTO on the GROUP definition statement. If you initially inhibit the text timeout value, NCP uses the value specified for ITEXTTO on the BUILD definition statement as the time limit between receipt of successive text characters.
- For BSC devices, code the WACK limit for WACKCNT on the GROUP definition statement. If you initially inhibit this limit, the first WACK received from the device causes NCP to return the request to the access method rather than respond to that and subsequent WACKs with an ENQ character.
- For start-stop devices, idle characters are automatically inserted following carriage return and horizontal tab characters. If you initially inhibit this function, no idle characters are sent.
- The subblocking defined by TRANSFR on the LINE definition statement. If you initially inhibit this subblocking, when the number of buffers specified by TRANSFR is filled with received text, NCP terminates the receive operation just as if the cutoff limit signified by CUTOFF on the LINE definition statement were reached.
- The recovery procedures for text-read errors specified by RETRIES on the LINE definition statement. If you initially inhibit these procedures, NCP does not attempt recovery for text-read errors.
- The recovery procedures for text-write errors specified by RETRIES on the LINE statement. If you initially inhibit these procedures, NCP does not attempt recovery for text-write errors.

### COMP

INHIBIT on the COMP definition statement specifies which NCP functions will not be enabled for an input or output component of a BSC or start-stop device when NCP is activated in the controller. The functions that can be initially inhibited are:

- The text timeout value defined by TEXTTO on the GROUP definition statement. If you initially inhibit the text timeout value, NCP uses the value specified for ITEXTTO on the BUILD definition statement as the time limit between receipt of successive text characters.
- The WACK limit for BSC devices defined by WACKCNT on the GROUP definition statement. If you initially inhibit this limit, the first WACK received from

## Controlling Adapter Overrun Errors

the component causes NCP to return the request to the access method rather than respond to that and subsequent WACKs with an ENQ character.

- Insertion of idle characters in text sent to start-stop devices. If you initially inhibit this function, no idle characters are sent following carriage return and horizontal tab characters.
- The subblocking you define for TRANSFR on the LINE definition statement. If you initially inhibit this subblocking, when the number of buffers specified by TRANSFR is filled with received text, NCP terminates the receive operation just as if the cutoff limit specified by CUTOFF on the LINE definition statement were reached.
- The recovery procedures for text-read errors specified by RETRIES on the LINE definition statement. If you initially inhibit these procedures, NCP does not attempt recovery for text-read errors.
- The recovery procedures for text-write errors specified by RETRIES on the LINE definition statement. If you initially inhibit these procedures, NCP does not attempt recovery for text-write errors.

---

## Transmission Interrupts

You can place a break signal on a line to interrupt transmission from a start-stop device that is capable of interrupting its transmission to NCP. This capability is defined by FEATURE on the TERMINAL definition statement.

Code the following definition statement and keyword to specify how NCP is to interrupt transmissions from terminals.

BUILD	XBREAK
-------	--------

XBREAK on the BUILD definition statement specifies whether NCP is to place the break signal on the line to interrupt transmission from a terminal, and if so, the duration of the break time, expressed in character times (the time required to transmit one character).

---

## Controlling Adapter Overrun Errors

The 3746 Model 900 uses small gaps between frames to achieve high utilization of high speed lines. This can cause some adapters to which the 3746 Model 900 transmits to experience an overrun error. You can eliminate these overrun conditions by specifying that you want the 3746 Model 900 to increase the size of the interframe gap.

Code the following definition statement and keyword to specify that you want the interframe gap to be larger.

LINE	ADDIFG
------	--------

ADDIFG on the LINE definition statement specifies whether the gap between frames should be made larger. This helps to keep the adjacent adapter from

getting overrun errors because larger interframe gaps cause the frame rate to decrease. Specifying a larger gap for 3746 Model 900 frame-relay, 3746 Model 900 SDLC, and 3746 Model 900 X.25 physical lines is recommended when the adjacent adapter to which this adapter is transmitting is experiencing overrun errors.

The interframe gap is made larger by increasing the minimum number of flags that the 3746 Model 900 transmits between frames. If the interframe gap should be made larger, code ADDIFG=YES to specify a minimum number of flags determined by line speed as follows:

256000 bps or greater: minimum flags = line speed / 8500  
 255999—25600 bps: minimum flags = line speed / 2560  
 25600 bps or less: minimum flags = 10

You can also specify the minimum number of flags based on your own determination. Code ADDIFG=*nn* where *nn* is the minimum number of flags to be used to create the interframe gap.

---

## Session Accounting

Session accounting is the collection of statistics about your network and sessions. You can incorporate the collection of accounting information into NCP or the gateway session accounting function of NCP.

Code the following definition statement and keyword to define session accounting characteristics.

BUILD	SESSACC
-------	---------

SESSACC specifies:

- Whether you want NCP to collect session accounting information.
- Whether you want session accounting done on primary logical units, secondary logical units, or both.
- Whether you want to defer data collection.
- The number of NPM session counter control blocks (NSCs) and NSC extensions (NSXs) NCP is to create for session accounting  
**Note:** You can cause NCP to dynamically create additional NSCs and NSXs when needed. See “Dynamically Created Control Blocks” on page 2-10 for more information.
- The number of bytes to be counted before session accounting data is sent to NPM.
- Whether you want session accounting done by PIU or by size frequency counts (control and text).

NCP can collect session accounting information for all peripheral function sessions only if you use NPM and code the SESSACC keyword. See “Network Performance Data Collection” on page 24-16 for more information.

## Network Performance Data Collection

You can use user-written accounting notification routines to collect data on IBM special products or user-written sessions. You can use such routines only if you use NPM and code the SESSACC keyword. See “Session Accounting for IBM Special Products or User-Written Code” on page 24-19 for more information.

---

## Network Performance Data Collection

The network performance analyzer is a function of NCP that runs in the communication controller. The data collected by the network performance analyzer is used by NetView Performance Monitor (NPM). For more information on NPM, see *Netview Performance Monitor at a Glance*.

There are two methods of collecting data to check network performance: basic data collection and data collection by transmission priority. This section describes how to define each of these functions.

### Basic Data Collection

Code the following definition statements and keywords to provide NCP with information about basic network performance data collection using the network performance analyzer.

BUILD	NPA
GROUP	NPARSC
LINE	NPACOLL
CLUSTER	NPACOLL
TERMINAL	NPACOLL
PU	NPACOLL
LU	MAXCOLL NPACOLL

### BUILD

NPA on the BUILD definition statement specifies whether NCP is to include the network performance analyzer function in the system generation definition. The network performance analyzer collects performance data about all of the following items that have network addresses:

- BSC lines supporting IBM 3270 devices exclusively, IBM 3270 BSC cluster controllers (physical units), and IBM 3270 BSC terminals (logical units)
- Channel links
- ESCON links
- Ethernet-type LAN lines
- Frame-relay physical and logical links
- ISDN B-channel and logical lines

- IBM special products or user-written code
- NCP
- SDLC links and SDLC physical units
- SDLC logical units and programmed resource virtual logical units
- Token-Ring physical and logical links.

When you code NPA=YES, NPM also collects data on the usage levels of many NCP control blocks and tables. You can use NTuneMON to monitor these usage levels. For more information, refer to *NTuneMON User's Guide*.

To collect performance and usage data for dynamically reconfigured logical units, such as Token-Ring logical units, code NPA=(YES,DR).

## GROUP

NPARSC on the GROUP definition statement specifies that this GROUP definition statement defines a programmed resource group that sends and receives network performance analyzer data and commands between NCP and NPM. Specify that the group supports programmed resources (VIRTUAL on the GROUP definition statement), and uses SDLC line control (LNCTL=SDLC on the GROUP definition statement). Code one LINE and one PU definition statement without any other keywords under the GROUP definition statement where you defined NPARSC=YES. You can code as many as eight LU definition statements under this GROUP definition statement and you can code MAXCOLL on these LU definition statements.

When you code multiple LU statements, it enables you to have multiple NCP-NPM sessions. One NCP-NPM session is designated as primary, and up to seven other NCP-NPM sessions function as hot backups. Hot backups transport only session accounting data, RNAAs, and FNAs, and are always active.

**Note:** For spare and redefinable lines, NPARSC is not valid.

## LINE

NPACOLL on the LINE definition statement specifies whether data transmitted and received on the telecommunication link is to be eligible for collection by the network performance analyzer. If you choose to collect data for this link, then data is also eligible for collection for all devices attached to the link unless you code NPACOLL=NO on the related CLUSTER, TERMINAL, PU, and LU definition statements to show that you do not want data collected for those devices. If you decide not to collect data for this link, you cannot collect data from any devices attached to the link.

**Note:** If you code NPACOLL=YES on a GROUP definition statement, the default is NPACOLL=YES for all LINE definition statements within that group.

## CLUSTER

NPACOLL on the CLUSTER definition statement causes data sent to and from the cluster controller to be collected by the network performance analyzer. If you decide to collect data for this controller, also specify that data is to be eligible for collection for the link the controller is attached to. If you decide not to collect data for this controller, you cannot collect data from any devices attached to the cluster controller.

## TERMINAL

NPACOLL on the TERMINAL definition statement causes data sent to and from the station to be collected by the network performance analyzer. If you want data col-

## Network Performance Data Collection

lected for the station, also specify that data is to be eligible for collection for the cluster controller the station is attached to, and for the telecommunication link the controller is attached to.

**Note:** Code NPACOLL on the CLUSTER and TERMINAL definition statements if you define a clustered BSC IBM 3270 Information Display System station.

### PU

NPACOLL on the PU definition statement causes data from NCP channel adapter traffic sent to and from the device to be collected by the network performance analyzer. If you choose to collect data for this device, also specify that data is to be eligible for collection for the link that the device is attached to. If you choose not to collect data for this device, you cannot collect data from any logical units associated with the device.

### LU

MAXCOLL on the LU definition statement specifies the maximum number of resources defined to your NCP that NPA can collect data for at the same time. MAXCOLL is valid only on LU definition statements that belong to the NPM programmed resource group. To define the NPM resource group, code (NPARSC=YES) on the GROUP definition statement.

**Note:** Do not choose an excessive value because it wastes NCP storage.

**3746 Model 900 Token Ring:** 3746 Model 900 Token-Ring resources do not use the storage reserved by MAXCOLL. Therefore, do not include these resources when calculating the value of MAXCOLL.

NPACOLL on the LU definition statement causes data that is transmitted and received by the logical unit to be collected by the network performance analyzer. If you want data collected for this logical unit, also specify that data is to be eligible for collection for the SDLC device this logical unit is associated with, and for the telecommunication link to which the device is attached.

## Data Collection by Transmission Priority

To expedite the processing of important data, every PIU is assigned a high, medium, or low transmission priority. When there is contention for network resources, higher-priority PIUs are transmitted before lower-priority PIUs. You can collect performance data on a particular line or physical unit for each transmission priority level. This method can give you a better idea of how the line or physical unit is being utilized in the network than the basic data collection method described in "Basic Data Collection" on page 24-16.

Code the following definition statements and keywords to provide NCP with information about the collection of network performance data by transmission priority.

BUILD	NPA
LINE	NPACOLL NPATP
PU	NPACOLL NPATP
LU	MAXCOLL MAXTP

### BUILD

NPA on the BUILD definition statement determines whether NCP is to include the network performance analyzer function in the system generation definition. Code NPA=(YES,DRTP) if you want network performance data collected by transmission priority for dynamic reconfiguration resources in addition to the basic network performance data to be collected for these resources.

### LINE

NPACOLL on the LINE definition statement specifies that data transmitted and received on the link is eligible for collection by the network performance analyzer.

NPATP specifies that data transmitted and received on the link is eligible for collection by transmission priority by the network performance analyzer. Code NPACOLL=YES if you code NPATP=YES.

### PU

NPACOLL on the PU definition statement specifies that data transmitted and received from the SDLC device is eligible for collection by the network performance analyzer.

NPATP specifies that data sent to and from the SDLC device is eligible for collection by transmission priority by the network performance analyzer. Code NPACOLL=YES if you code NPATP=YES.

### LU

MAXCOLL on the LU definition statement determines how many resources are eligible for data collection at one time by the network performance analyzer.

MAXTP defines how many resources are eligible for data collection by transmission priority at one time by the network performance analyzer. MAXTP is valid only on LU definition statements that belong to the NPM programmed resource group. If both MAXTP and MAXCOLL are coded, the value coded on the MAXTP keyword cannot exceed the value coded on the MAXCOLL keyword.

---

## Session Accounting for IBM Special Products or User-Written Code

Code the following definition statements and keywords to provide NCP with information about how to define the appropriate load modules and linkage editor statements for IBM special products or user-written code session accounting.

## MTA Terminals

OPTIONS	USERGEN
GENEND	INCL2HI ORDL2HI UACCTNG

### OPTIONS

USERGEN on the OPTIONS definition statement specifies the names of the generation application load modules or IBM products that use the NDF standard attachment facility. Each generation application must have a separate generation application load module to process its definition statements and keywords and generate table source statements and linkage editor commands. You can specify a maximum of 25 generation load modules in a single generation.

### GENEND

INCL2HI on the GENEND definition statement specifies library members that contain linkage-editor INCLUDE statements for object modules that are level 2 or level 3 code. These object modules can reside anywhere in controller storage.

ORDL2HI specifies library members containing linkage-editor ORDER statements for object modules that are level 2 or level 3 code. These object modules can reside anywhere in controller storage.

UACCTNG specifies the entry points of one or more user-written accounting notification routines. User-written accounting routines are valid only if NCP is collecting session data because you coded SESSACC=YES on the BUILD definition statement.

If you code UACCTNG to specify entry points for user-written modules, code either USERGEN on the OPTIONS definition statement or INCL2HI and ORDL2HI on the GENEND definition statement to include the object modules in the generation definition.

---

## MTA Terminals

Code the following definition statements and keywords to provide NCP with information about how to define timeout values to improve the performance of MTA terminals.

BUILD	MTARTO MTARTRY
-------	-------------------

MTARTO on the BUILD definition statement defines the reply timeout value NCP uses when it is called by an MTA terminal.

MTARTRY defines how many times NCP retries the MTA signon procedure after it identifies the type of MTA terminal that called it.



---

## Link Session Priority

When a transmission priority is used, PIUs with a high transmission priority are sent to the physical unit before those with a lower priority. When a transmission priority is not used, PIUs are sent to the physical unit in a first-in-first-out sequence.

Code the following definition statements and keywords to provide NCP with information about how to define link session priority.

GROUP	LSPRI
LINE	LSPRI

LSPRI on the GROUP and LINE definition statements specifies whether transmission priority should be used to determine the order in which PIUs are sent to the physical unit. When you code LSPRI=LINK, NCP replaces the SOT with a priority queue for PIU transmission. The SOT is still used for polling.

If you define a line group that uses IBM special products or user-written code for level 2 processing, code LSPRI=YES on the GROUP definition statement to indicate that level 2 processing can support segmented PIUs. LSPRI is valid only for peripheral SDLC lines, peripheral NTRI physical lines, 3746 Model 900 Token-Ring physical lines, and lines belonging to IBM special products or user-written code.



---

## Chapter 25. Backup and Recovery Procedures

NCP provides protection for the devices attached to your NCP if any of the other network resources fail. This chapter describes different protection features and the procedures to follow to maintain the system integrity of your resources.

---

### Defining Automatic Network Shutdown

Automatic network shutdown (ANS) occurs when NCP can no longer communicate with an access method that owns some of the link-attached devices of NCP.

ANS produces the following results for BSC and start-stop telecommunication links:

- NCP dissociates a link from the owning access method with which communication was lost.
- NCP cancels any line traces or online tests being performed on the link.
- NCP cancels the command currently running for the link.
- NCP breaks the switched connection if the link is switched.

ANS produces the following results for BSC and start-stop devices:

- NCP cancels any commands currently pending for the device.
- NCP sends a predefined message to devices that you specify to receive this message, notifying them of the impending shutdown.
- NCP cancels any sessions in which the device is currently active.
- NCP stops general polling of BSC clustered stations.
- NCP resets a start-stop device if monitor mode is currently in effect for the device.

ANS produces the following results for SDLC telecommunication links:

- NCP dissociates a link from the owning access method with which communication has been lost.
- NCP cancels any line traces or online tests being carried out on the link for the access method with which communication was lost.

ANS produces the following results for SDLC devices:

- If the device is attached to either a nonswitched telecommunication link or a switched telecommunication link and you specify that it is to continue operating in a cross-domain session, NCP continues to service the device although it is in shutdown mode. The device continues to participate in sessions with access methods not affected by the shutdown.
- If the device is attached to either a nonswitched telecommunication link or a switched telecommunication link and you specify that it is to stop operating, NCP deactivates the device.

## Defining Automatic Network Shutdown

- If the device is attached to a switched link with user line control that is to continue operating, NCP does not deactivate the link. (Note that ANS=CONTINUE is only valid for switched links if user line control is specified.) Because NCP does not automatically disconnect the switched line defined with ANS=CONTINUE, be sure you define switched user-line-control lines with ANS=CONTINUE only under the following conditions:
  - If you want permanent connectivity of the link.
  - If the link is to have associated logical units that participate in cross-domain sessions. You need to be aware of this condition because the applications in an owning host are lost when connectivity to this host is lost.
- If the device is another communication controller, NCP will continue to communicate with it.

ANS produces the following results for NTRI resources:

- NTRI resources can be stopped when NCP enters ANS mode.
- NTRI resources can continue operating when NCP enters ANS mode.
- NTRI resources can be stopped when the VTAM operator does a forced deactivation of NCP. For all other causes of ANS, NTRI resources continue to operate.

ANS produces the following results for channel links:

- NCP dissociates a link from the owning access method with which communication has been lost.
- NCP cancels any line traces being carried out on the link for the access method with which communication has been lost.

ANS produces the following results for peripheral channel devices:

- If you specify that the device is to continue operating in a cross-domain session, NCP continues to service the device although it is in shutdown mode. The device continues to participate in sessions with access methods not affected by the shutdown.
- If you specify that the device is to stop operating, NCP deactivates the device.

Code the following definition statement and keywords to provide NCP with information about how to define ANS, message information, and an ANS value for individual devices.

BUILD	CSMHDR CSMHDRC CSMSG CSMSGC
LINE	ANS
PU	ANS
TERMINAL	CRITSIT

### BUILD

CSMHDR and CSMHDC on the BUILD definition statement define the header used in the critical-situation message that NCP sends to IBM 3270 Information Display System clustered stations. The message notifies each station of an impending shutdown. The header must contain the appropriate device control characters and can include any other valid characters desired. See *IBM 3270 Component Description* for the required device control characters. The header specified by these keywords is sent only to IBM 3270 stations.

CSMSG and CSMSGC define the text used in the critical situation message that NCP sends to each active BSC or start-stop device to notify it of an impending shutdown.

### LINE

ANS on the LINE definition statement enables immediate or delayed automatic network shutdown processing when NCP can no longer communicate with an access method that owns some of the NCP BSC 3270 lines and devices.

If you decide to delay ANS processing, note the following changes in network operation:

- If the SSCP session is lost, NCP does not end application sessions. If you lose the application sessions, the IBM 3270 terminal is hung until the line is activated or NCP reloaded.
- Lost control point notification is not sent.
- Critical situation messages are sent when the delayed ANS processing occurs.

### PU

ANS on the PU definition statement determines whether an SDLC device continues operating or stops when your NCP enters ANS. Switched physical units, except for those physical units attached with user line control, ignore the ANS value in the NCP generation definition and use instead the ANS value in the VTAM switched major node definition.

Session continuation for switched connections is fully supported with a VTAM release later than V3R1.1 because the ANS setting is always sent to NCP at activation time. If your VTAM release is V3R1.1 or earlier, session continuation for switched connections is supported only when user line control is specified on the GROUP statement.

### TERMINAL

CRITSIT on the TERMINAL definition statement specifies whether NCP sends a message to the BSC or start-stop device to notify it of an impending shutdown. This is the message you code for CSMSG and CSMSGC on the BUILD definition statement. NCP does not automatically send a message to notify devices when the network is again operational; this is the responsibility of the access method.

---

### Error Recovery and Recording

Code the following definition statements and keywords to provide NCP with information about error recovery attempts for individual devices.

GROUP	CRETRY
LINE	ETRATIO RETRIES
TERMINAL	SRT
COMP	SRT
PU	IRETRY RETRIES SRT

#### GROUP

CRETRY on the GROUP definition statement defines the maximum number of error recovery attempts you want NCP to make if recoverable errors occur during polling and addressing operations on any BSC or start-stop telecommunication link in the group.

#### LINE

ETRATIO on the LINE definition statement specifies the error-to-transmission ratio for the SDLC or BSC telecommunication link. Programs that analyze statistical maintenance records use this ratio.

RETRIES specifies how many attempts NCP is to make to recover from errors that occur during transmission over a link. RETRIES provides for recovery of a temporary error using a value that does not prevent recognition of a permanent error. Code RETRIES if the telecommunication link can operate in network control mode.

#### Notes:

1. For BSC and start-stop telecommunication links, if NCP encounters an error while sending data to a BSC or start-stop device, it retransmits the block on which the error occurred. NCP stops retransmission until it sends the block successfully or until it attempts the number of RETRIES you define. If an error occurs while NCP is receiving data from a BSC or start-stop device, it sends a negative response to the device, causing it to retransmit the block in error until (1) the block is successfully received, (2) the device sends an end-of-transmission (EOT) character or sequence instead of retransmitting the block, or (3) NCP sends the device the number of negative responses you define for RETRIES.
2. For SDLC telecommunication links and NTRI logical links, RETRIES defines the number of retries that occur inside a retry sequence for sessions involving a local IBM Token-Ring Network. Code a pause value of several seconds between sequences to allow time for transient noise conditions on the link, which may be responsible for the repeated errors, to subside. An error condition occurs when NCP does not receive a positive indication that a frame it sent was successfully received. NCP continues to retransmit the frame until the

frame is successfully received or until it attempts the number of RETRIES you define. If an error occurs while NCP is receiving data from an SDLC device, it sends the device a command that causes the device to retransmit all frames starting with the frame in error. NCP repeats this command until (1) it successfully receives the frame, (2) it retries the receive operation the number of times you define for RETRIES, or (3) the device sends an abnormal response (for example, a request for initialization).

3. If you define a subarea link connecting two NCPs, be aware that there are minimum retry values to be used when loading or dumping a link-attached NCP over the link. See *NCP, SSP, and EP Resource Definition Reference* for these minimum values.

### TERMINAL, COMP, and PU

SRT on the TERMINAL, COMP, and PU definition statements defines a threshold value for the total number of PIUs the BSC device can send or receive, and a threshold value for the total number of temporary errors that can occur for this device. If either threshold is reached, NCP notifies the access method by generating a record maintenance statistics (RECMS) request/response unit (RU).

For LPDA-2 channelized lines on ports B, C, or D, NCP routes all tests through the port A line. Because this impacts performance on the port A line, code high threshold values for SRT, or use the maximum default values. This reduces performance degradation on the port A line that runs the LPDA tests for ports B, C, and D.

For LPDA-1 or no LPDA, NCP builds a RECMS; for LPDA-2, NCP builds an NMVT.

The error-records database for the operating system stores the RECMS RU data. An application program that collects communication network management (CNM) data from the network can also use the RU. For example, NetView Performance Monitor can organize and present the data to network problem determination operators. This data is even more valuable if the telecommunication link supports LPDA modems. In addition to recording the ratio of retransmissions caused by errors to the total traffic, LPDA reports include information on the quality of the link as a transmission medium.

On the TERMINAL and COMP definition statements, the device is a BSC device; on the PU definition statement, the device is an SDLC device.

Code SRT on the PU definition statement to prevent LPDA-1 and LPDA-2 tests from being executed on the line when the total-transmissions counter reaches its threshold.

IRETRY on the PU definition statement specifies whether NCP repolls a given secondary station before advancing to the next station in the service order table. If the primary station detects an error during a polling cycle, and you specify that NCP repoll a secondary station, it does so before advancing to the next station in the service order table. NCP will repoll a station as many times as you define for RETRIES on the LINE definition statement. Code IRETRY only for SDLC telecommunication links.

RETRIES on the PU definition statement specifies the number of attempts NCP makes to recover from errors occurring during transmission to or from the SDLC device. Code this keyword along with RETRIES on the LINE definition statement.

---

### Backup Sessions for SDLC Devices

The extended recovery facility (XRF) provides the capability for a second host subsystem to take over LU-LU sessions in the event of a failure of the active subsystem. The takeover is accomplished with minimal disruption to the session.

Code the following definition statement and keyword to provide NCP with information about backup sessions for SDLC devices.

BUILD	BACKUP
-------	--------

BACKUP on the BUILD definition statement defines the total number of logical units that use XRF. Storage can be wasted if you define more backup logical units than necessary.

**Note:** You can cause NCP to dynamically create additional resources for backup logical units when needed. This enables NCP to support more backup sessions than the number specified by BACKUP. See “Dynamically Created Control Blocks” on page 2-10 for more information.



---

# Appendixes

<b>Appendix A. NCP V7R8 Sample Generation Definitions</b> . . . . .	A-1
Sample Network Connections . . . . .	A-4
NCP A03 . . . . .	A-4
NCP A04 . . . . .	A-4
NCP A31 . . . . .	A-5
NCP B31 . . . . .	A-5
NCP B75 . . . . .	A-5
NCP C04 . . . . .	A-6
NCP A03 Sample Generation Definition . . . . .	A-7
NCP A04 Sample Generation Definition . . . . .	A-39
NCP A31 Sample Generation Definition . . . . .	A-82
NCP B31 Sample Generation Definition . . . . .	A-128
NCP B75 Sample Generation Definition . . . . .	A-155
NCP C04 Sample Generation Definition . . . . .	A-191
<b>Appendix B. SSP Generated Inputs to NETDA/2</b> . . . . .	B-1



---

## Appendix A. NCP V7R8 Sample Generation Definitions

This section describes a sample network configuration with different types of NCP connections and device attachments. These NCP connections and device attachments are described in the previous chapters of this book. The network consists of six NCPs with support for the following types of connections:

- BSC and SDLC lines
- Multipoint SDLC subarea links
- 3745 frame-relay subarea and peripheral links
- 3746 Model 900 frame-relay subarea links
- NTRI and 3746 Model 900 Token-Ring subarea and peripheral links
- Internet routing over Ethernet-type LANs, NTRI-attached Token Rings, frame relay, and channel
- ESCON and System/370 channel attachments
- Frame relay over Token Ring
- Frame relay boundary access node
- ISDN subarea and peripheral links
- Internal NCP to Model 900 point-to-point IP connection

Figure A-1 on page A-3 shows the relationships between the six NCPs and some of the different connections that can be defined. When you examine the network connections in Figure A-1 and in the sample generation definitions, you may find many similarities to your own network configuration. In some instances, connections between NCPs are not labeled with addresses (for example, A04 and A03). This is due to the multiple connection capabilities defined in the gen. You will find a complete system generation definition beginning on page A-7 of this section for each of the NCPs shown in Figure A-1.

These tested sample generation definitions are included on the SSP product tape you receive with SSP installation materials. Use these samples to suggest coding solutions for certain resources in your own network configuration. You may find them particularly helpful when you define the NCP resources described in this book. Remember that each configuration is unique, and your system generation definition should be tailored to match your resources and your naming conventions.

Table A-1 on page A-2 lists NCP functions (with an indication of what release the functions were added in), provides the name of a sample generation definition with each function, and gives a page number where you can find an example of the coding.

## Sample Generation Definitions

<i>Table A-1. Functions Included in Sample Definitions</i>			
<b>Function</b>	<b>Release Added</b>	<b>Generation Definition</b>	<b>Location</b>
3746 Model 900 frame relay	V7R3	NCP A04	Page A-39
		NCP A31	Page A-82
Dynamic internet routing	V7R1	NCP A03	Page A-7
		NCP B31	Page A-128
Internet routing over a NTRI-attached Token Ring	V7R1	NCP A03	Page A-7
		NCP B31	Page A-128
Internet routing over frame relay	V7R3	NCP A03	Page A-7
		NCP B31	Page A-128
Frame relay over Token Ring	V7R3	NCP B75	Page A-155
		NCP C04	Page A-191
BAN connection	V7R3	NCP B75	Page A-155
		NCP C04	Page A-191
Frame-relay peripheral links	V7R1	NCP A31	Page A-82
Dynamically created control blocks	V7R1	All	
ISDN support	V7R5	NCP A04	Page A-39
		NCP A31	Page A-82
Internal NCP to Model 900 point-to-point IP connection	V7R6	NCP B31	Page A-128

For a sample generation definition of the X.25 ODLC function added with NCP V7R4, see *NCP Version 7 and X.25 NPSI Version 3 Planning and Installation*.

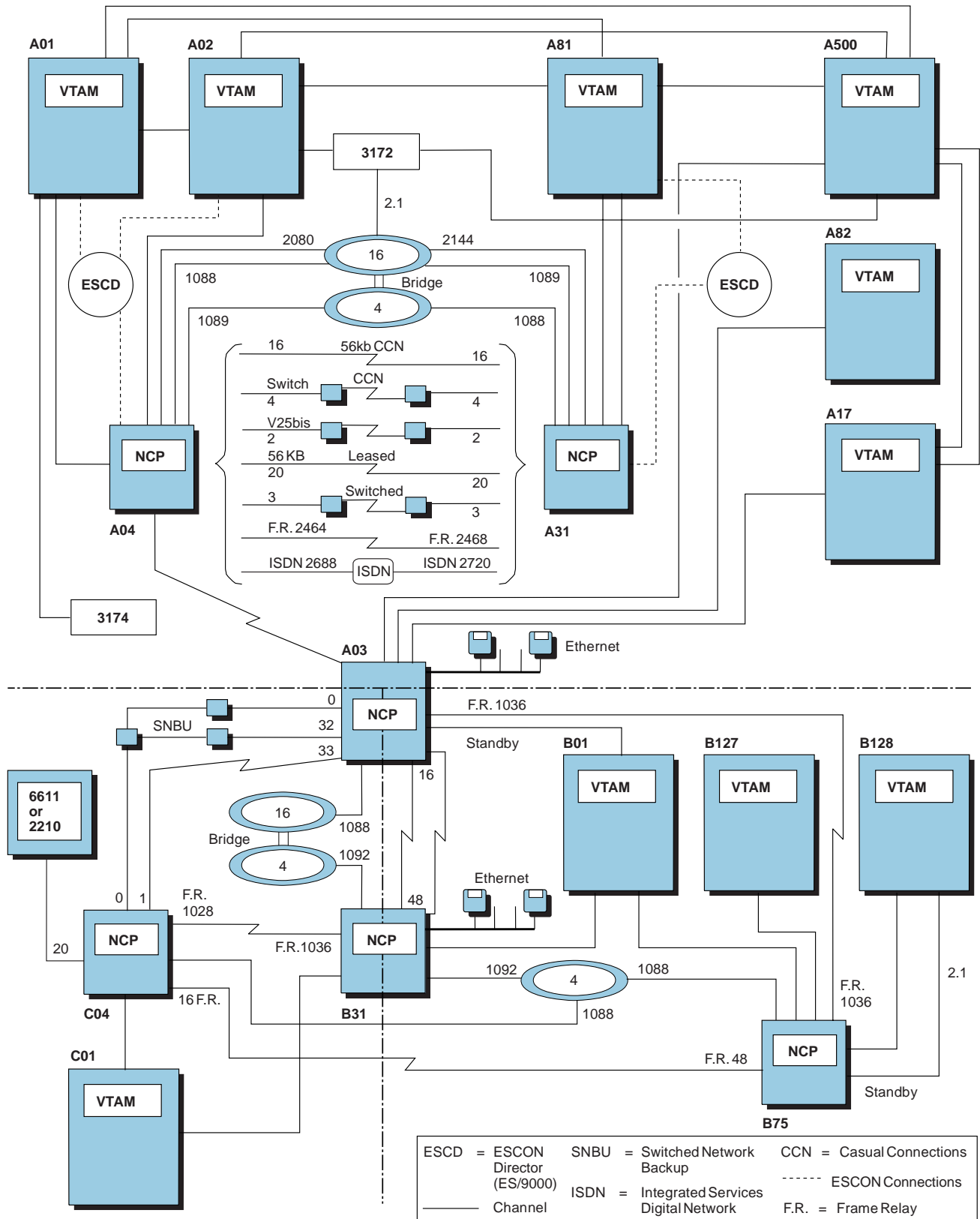

Figure A-1. Sample Network Connections

### Sample Network Connections

This section describes the connections for each NCP shown in Figure A-1 on page A-3 and defined in the generation definitions that begin on page A-7.

#### NCP A03

- Connected to:
  - Host A17 (type 7 channel link)
  - Host A82 (type 7 channel link)
  - Host A500 (type 7 channel link)
  - Host B01 (type 7 channel link)
  - NCP A04 (one SDLC subarea link—secondary side of multipoint link)
  - NCP B31 (two nonswitched 56KB subarea links)
    - (16 Mbps Token-Ring connection—subarea and peripheral, supporting both SNA and internet traffic)
    - (16 Mbps Token-Ring connection—peripheral)
    - (two 16 Mbps Token-Ring connections—duplicate TICs)
    - (frame-relay subarea link with IP routing capabilities)
    - (frame-relay subarea link through NCP B75 and NCP C04)
  - NCP C04 (3 nonswitched 9.6KB subarea links—two are SNBU).

#### NCP A04

- Connected to:
  - Host A01 (type 7 channel link—ESCON connection)
  - Host A02 (type 7 channel link—ESCON connection)
  - NCP A03 (SDLC subarea link—primary side of multipoint link)
  - NCP A31
    - (two nonswitched 56KB subarea links)
    - (nonswitched 9.6KB subarea link for LPDA testing)
    - (nonswitched 9.6KB subarea link—3746 Model 900 SDLC)
    - (nonswitched 56KB subarea link—3746 Model 900 SDLC)
    - (nonswitched T1 subarea link—3746 Model 900 SDLC)
    - (two switched 9.6KB subarea links)
    - (switched 9.6KB subarea link—3746 Model 900 SDLC)
    - (two switched 1200 bps subarea links—V.25 bis)
    - (switched 1200 bps subarea link—3746 Model 900 SDLC, V.25 bis)
    - (two casual connections—switched lines)
    - (two casual connections—nonswitched 56KB lines)
    - (casual connection—switched 3746 Model 900 SDLC)
    - (casual connection—nonswitched 56KB peripheral 3746 Model 900 SDLC)
    - (two 4 Mbps Token-Ring connections—peripheral only)
    - (two 4 Mbps Token-Ring connections—peripheral only)
    - (16 Mbps Token-Ring connection—TIC3)
    - (56KB subarea link—3746 Model 900 frame relay)
    - (ISDN interface with subarea link)
    - (ISDN interface with peripheral link)

**NCP A31**

- Connected to:
  - Host A81 (two type 7 channel links—ESCON connection)
  - NCP A04 (nonswitched 9.6KB subarea link for LPDA testing)
    - (two nonswitched 56KB subarea links)
    - (nonswitched 9.6KB subarea link—3746 Model 900 SDLC)
    - (nonswitched 56KB subarea link—3746 Model 900 SDLC)
    - (nonswitched T1 subarea link—3746 Model 900 SDLC)
    - (switched 9.6KB subarea link)
    - (switched 9.6KB subarea link—3746 Model 900 SDLC)
    - (two switched 1200 bps subarea links—V.25 bis)
    - (switched 1200 bps subarea link—3746 Model 900 SDLC, V.25 bis)
    - (two casual connections—switched lines)
    - (two casual connections—nonswitched 56KB lines)
    - (casual connection—switched 3746 Model 900 SDLC)
    - (casual connection—nonswitched 56KB peripheral 3746 Model 900 SDLC)
    - (two 4 Mbps Token-Ring connections—subarea and peripheral)
    - (two 16 Mbps Token-Ring connections—peripheral only)
    - (16 Mbps Token-Ring connection—TIC3)
    - (two 9.6KB frame-relay peripheral links to IBM 3276s)
    - (56KB subarea link—3746 Model 900 frame relay)
    - (ISDN interface with subarea link)
    - (ISDN interface with peripheral link)

**NCP B31**

- Connected to:
  - Host B01 (type 7 channel link)
  - Host C01 (type 7 channel link)
  - NCP A03 (nonswitched 56KB subarea link)
    - (4 Mbps Token-Ring connection—subarea and peripheral, supporting both SNA and internet traffic)
    - (4 Mbps Token-Ring connection—peripheral only)
    - (frame-relay subarea link with IP routing capabilities)
    - (frame-relay subarea link through NCP C04)
  - NCP B75 (uses Token-Ring connections described under NCP A03).

**NCP B75**

- Connected to:
  - Host B01 (type 7 channel link)
  - Host B127 (type 7 channel link)
  - Host B128 (type 7 channel link—casual connection)
  - NCP A03 (FRFH connection for A03-B31 subarea link)
  - NCP B31 (16 Mbps Token-Ring connection—subarea and peripheral)
    - (frame-relay subarea link through NCP C04)
  - NCP C04 (FRFH connections for A03-B31 subarea link).
  - NCP BAN connection to a router (for example, 6611 or 2210)

### NCP C04

- Connected to:
  - Host C01 (type 7 channel link)
  - NCP A03 (two nonswitched 9.6KB subarea links—one is SNBU)
  - NCP B31 (FRFH connection for A03-B31 and B31-B75 subarea links)
  - NCP B75 (FRFH connections for A03-B31 and B31-B75 subarea links).
  - NCP BAN connection to a router (for example, 6611 or 2210))



## NCP A03 Sample Generation Definition

```

*****
***** IFWA03 - NCP FOR SAMPLES NETWORK SUBAREA 03 *****
*****
*
*          |-----| |-----| |-----|
*          | HOST | | HOST | | HOST |
*          | A17N | | A500N | | A82N |
*          |-----| |-----| |-----|
*
*          CA-1      | | | |      CA-3      CA-5
*          TGN=1     | | | |      TGN=2     TGN=1
*
*          |-----|
*          | NETID=NETA |
*          | NCP IFWA03 |
*          | SA=03      |
*          |-----|
*          CA-7      |
*          TGN=1     |
*          |-----|
*          | HOST |-----| NETID=NETB | MODEL
*          | B01N |-----| SA=03      | SA=31
*          |-----|
*
*****
*
* LINE          FUNCTION
* ----          -
* 000          LEASED SDLC 9.6KB SNBU TO LINE 0 IN IFWC04 IN NETC
* 001          MULTIPOINT SDLC LINE - DLU'S & ILU'S
* 002          BSC LEASED LINE
* 003          MULTIDROP SUBAREA FROM IFWA04
* 004          MULTIDROP SUBAREA FROM IFWA04
* 016          LEASED 56KB SUBAREA TO LINE 48 IFWB31 IN NETB
* 020          LEASED 56KB DR
* 032          LEASED SDLC 9.6KB SNBU BACKUP TO IFWC04 IN NETC
* 033          LEASED 9.6KB SUBAREA TO LINE 16 IFWC04 IN NETC
* 034          LEASED 9.6KB DR
* 035          LEASED 9.6KB DR
* 048          LEASED 56KB SUBAREA TO LINE 16 IFWB31 IN NETA
* 052          FULL DUPLEX 56KB FRAME RELAY (IP over FR)
*             DLCI TO IFWB31 052
* 1028         FULL DUPLEX HPTSS SDLC TO IFWA04 1028
* 1036         FULL DUPLEX HPTSS FRAME RELAY
*             DLCI TO IFWB31 1036
* 1070         ETHERNET
* 1071         ETHERNET
*             NCST LU TO IFWB31
*             NCST LU TO A17N
*             NCST LU TO A01N

```

Figure A-2 (Part 1 of 32). NCP A03 Sample Generation Definition

## NCP A03 Sample Generation Definition

```
* 1088      TOKEN RING SUBAREA AND PERIPHERAL
*          SUBAREA LOGICAL TO IFWB31 1092 IN NETC (NETA,ANY)
*          IP OVER TOKEN RING CONNECTION TO IFWB31 1092
* 1089      TOKEN RING PERIPHERAL ONLY
* 1092      TOKEN RING PERIPHERAL ONLY - DUPLICATE TIC
* 1093      TOKEN RING PERIPHERAL ONLY - DUPLICATE TIC
*
*
*****
*
*****
*          NCP OPTIONS MACRO - MISCELLANEOUS OPTIONS          *
*****
*
          OPTIONS NEWDEFN=(YES,ECHO)
*
*****
*          VTAM PCCU MACRO - HOSTS THAT WILL ACTIVATE THIS NCP      *
*****
*
APCCU1  PCCU AUTOSYN=YES,                                     *
          BACKUP=YES,                                         *
          CDUMPDS=CSPDUMP,                                     *
          CONFGDS=CRNCKPT,                                     *
          DUMPDS=VTAMDUMP,                                     *
          GWCTL=SHR,                                           *
          MAXDATA=4096,                                        *
          MDUMPDS=MOSSDUMP,                                    *
          NETID=NETA,                                          *
          OWNER=A500N,                                         *
          SUBAREA=500,                                         *
          TGN=ANY
*
APCCU2  PCCU AUTOSYN=YES,                                     *
          BACKUP=YES,                                         *
          CDUMPDS=CSPDUMP,                                     *
          CONFGDS=CRNCKPT,                                     *
          DUMPDS=VTAMDUMP,                                     *
          GWCTL=SHR,                                           *
```

Figure A-2 (Part 2 of 32). NCP A03 Sample Generation Definition

## NCP A03 Sample Generation Definition

```

MAXDATA=4096,
MDUMPDS=MOSSDUMP,
NETID=NETA,
OWNER=A17N,
SUBAREA=17
*
APCCU4  PCCU AUTOSYN=YES,
        BACKUP=YES,
        CDUMPDS=CSPDUMP,
        CONFGDS=CRNCKPT,
        DUMPDS=VTAMDUMP,
        GWCTL=SHR,
        MAXDATA=4096,
        MDUMPDS=MOSSDUMP,
        NETID=NETB,
        OWNER=B01N,
        SUBAREA=01
*
*****
*   NCP BUILD MACRO - NCP/CONTROLLER INFO   *
*****
IFWA03  BUILD ADSESS=500,
        AUXADDR=500,
        BFRS=128,
        BRANCH=8000,
        CATRACE=(YES,255),
        CNLSQMAX=10000,
        CNLSQTIM=10,
        CSMSG=C3D9C9E340E2C9E340D4C5E2E2C1C7C540C6D6D940E2E24040*
        40C2C340E3C5D9D4C9D5C1D3,
        CWALL=26,
        DYNNSC=50,
        DYNNSX=50,
        DYNPOOL=(50,35),
        ENBLTO=30.0,
        ERLIMIT=16,
        GWSESAC=(YES,NODEFER,,1000,500,,10,11,12,13,14,15),
        HSBPOOL=6000,
        IPPOOL=NCP,
        IPRATE=(40,50),
        LOADLIB=NCPLoad,
        LTRACE=8,

```

Figure A-2 (Part 3 of 32). NCP A03 Sample Generation Definition

## NCP A03 Sample Generation Definition

```

MAXSESS=250,
MAXSSCP=8,
MODEL=3745-210,
NAMTAB=120,
NETID=NETA,
NEWNAME=IFWA03,
NPA=(YES,DR),
NUMHSAS=8,
OLT=YES,
PWROFF=YES,
SALIMIT=1023,
SESSACC=(YES,ALL,,1000,500,,10,11,12,13,14,15),
SLOWDOWN=12,
SUBAREA=03,
TRACE=(YES,100),
TRANSFR=41,
TYPGEN=NCP,
TYP SYS=MVS,
T2TIMER=(1.9,2.0,45),
USGTIER=5,
VERSION=V7R3,
VRPOOL=150,
VRTIMER0=(180,,50),
VRTIMER1=(180,,50),
VRTIMER2=(180,,50),
T1TIMER=(19.0,20.0)
*
*****
* DYNAMIC CONTROL FACILITIES USED BY VTAM *
*****
*
SYSCNTRL OPTIONS=(BACKUP,BHSASSC,DLRID,DVSINIT,ENDCALL,LNSTAT,*
MODE,NAKLIM,RCNTRL,RCOND,RDEVQ,RECMD,RIMM,SESINIT,SESSIO*
N,SSPAUSE,STORDSP,XMTLMT)
*
*****
* NCP HOST MACRO - CHANNEL ATTACHED HOST DEFINITIONS *
*****
*
A17N HOST BFRPAD=0,
MAXBFRU=16,
NETID=NETA,
SUBAREA=17,
UNITSZ=256
*

```

Figure A-2 (Part 4 of 32). NCP A03 Sample Generation Definition

## NCP A03 Sample Generation Definition

```

*
A500N  HOST BFRPAD=0,
          MAXBFRU=16,
          NETID=NETA,
          SUBAREA=500,
          UNITSZ=256
*
*
B01N   HOST BFRPAD=0,
          MAXBFRU=16,
          NETID=NETB,
          SUBAREA=01,
          UNITSZ=256
*
*
*****
*   NATIVE NETWORK DEFINITIONS
*   *****
*
      GWNAU NETID=NETB,NAME=B01N,NUMSESS=5,ELEMENT=1
      GWNAU NETID=NETB,NAME=B128N,NUMSESS=5,ELEMENT=2
      GWNAU NETID=NETC,NAME=C01N,NUMSESS=5,ELEMENT=3
*
      GWNAU NUMADDR=600
*
*****
*   PATH DEFINITIONS
*   *****
      PATH DESTSA=(1,2,4,81,31),
          ER0=(4,1,5000,5000,5000,20000),
          ER1=(4,1),
          ER2=(4,1),
          ER3=(4,1),
          ER4=(4,1),
          ER5=(4,1),
          ER6=(4,1),
          ER7=(4,1),
          VR0=0,
          VRPWS00=(1,3),VRPWS01=(1,3),VRPWS02=(1,3),
          VR1=1,
          VRPWS10=(2,6),VRPWS11=(2,6),VRPWS12=(2,6),
          VR2=2,
          VRPWS20=(3,9),VRPWS21=(3,9),VRPWS22=(3,9),
          VR3=3,
          VRPWS30=(3,9),VRPWS31=(3,9),VRPWS32=(3,9),

```

Figure A-2 (Part 5 of 32). NCP A03 Sample Generation Definition

## NCP A03 Sample Generation Definition

```

VR4=4, *
VRPWS40=(3,9),VRPWS41=(3,9),VRPWS42=(3,9), *
VR5=5, *
VRPWS50=(3,9),VRPWS51=(3,9),VRPWS52=(3,9), *
VR6=6, *
VRPWS60=(3,9),VRPWS61=(3,9),VRPWS62=(3,9), *
VR7=7, *
VRPWS70=(3,9),VRPWS71=(3,9),VRPWS72=(3,9)
PATH DESTSA=17, *
ER0=(17,1,5000,5000,5000,20000), *
ER1=(17,1), *
ER2=(17,1), *
ER3=(17,1), *
ER4=(17,1), *
ER5=(17,1), *
ER6=(17,1), *
ER7=(17,1), *
VR0=0, *
VRPWS00=(1,3),VRPWS01=(1,3),VRPWS02=(1,3), *
VR1=1, *
VRPWS10=(2,6),VRPWS11=(2,6),VRPWS12=(2,6), *
VR2=2, *
VRPWS20=(3,9),VRPWS21=(3,9),VRPWS22=(3,9), *
VR3=3, *
VRPWS30=(3,9),VRPWS31=(3,9),VRPWS32=(3,9), *
VR4=4, *
VRPWS40=(3,9),VRPWS41=(3,9),VRPWS42=(3,9), *
VR5=5, *
VRPWS50=(3,9),VRPWS51=(3,9),VRPWS52=(3,9), *
VR6=6, *
VRPWS60=(3,9),VRPWS61=(3,9),VRPWS62=(3,9), *
VR7=7, *
VRPWS70=(3,9),VRPWS71=(3,9),VRPWS72=(3,9)
PATH DESTSA=500, *
ER0=(500,1,5000,5000,5000,20000), *
ER1=(500,2,5000,5000,5000,20000), *
ER2=(17,1), *
ER3=(17,1), *
ER4=(500,1), *
ER5=(500,1), *
ER6=(500,1), *

```

Figure A-2 (Part 6 of 32). NCP A03 Sample Generation Definition

## NCP A03 Sample Generation Definition

```

ER7=(500,1), *
VR0=0, *
VRPWS00=(1,3),VRPWS01=(1,3),VRPWS02=(1,3), *
VR1=1, *
VRPWS10=(2,6),VRPWS11=(2,6),VRPWS12=(2,6), *
VR2=2, *
VRPWS20=(3,9),VRPWS21=(3,9),VRPWS22=(3,9), *
VR3=3, *
VRPWS30=(3,9),VRPWS31=(3,9),VRPWS32=(3,9), *
VR4=4, *
VRPWS40=(3,9),VRPWS41=(3,9),VRPWS42=(3,9), *
VR5=5, *
VRPWS50=(3,9),VRPWS51=(3,9),VRPWS52=(3,9), *
VR6=6, *
VRPWS60=(3,9),VRPWS61=(3,9),VRPWS62=(3,9), *
VR7=7, *
VRPWS70=(3,9),VRPWS71=(3,9),VRPWS72=(3,9)
*****
*   NCP SDLCST MACRO - SDLC SUBAREA COMMUNICATION CONTROLLER LINKS   *
*****
*
*
S03PRI   SDLCST GROUP=A03GPRI, *
          MODE=PRI
*
S03SEC   SDLCST GROUP=A03GSEC, *
          MODE=SEC
*
*****
*   NCP POOL MACROS - NECESSARY FOR DYNAMIC RECONFIGURATION         *
*   AND SWITCHED SDLC/NTRI                                           *
*****
*
          PUDRPOOL NUMBER=10
*
          LUDRPOOL NUMILU=150, *
          NUMTYP1=05, *
          NUMTYP2=150
*
*****
*   ADDRESS 002 : BSC LEASED LINE *
*****
*
A03BNNB2 GROUP AVGPB=125, *
          CLOCKNG=EXT, *
          CODE=EBCDIC, *
          CONV=YES, *
          CRETRY=7, *
          CRITSIT=NO, *

```

Figure A-2 (Part 7 of 32). NCP A03 Sample Generation Definition

## NCP A03 Sample Generation Definition

```
DIAL=NO, *
DIRECTN=INOUT, *
DLOGMOD=MBSCQ, *
DUPLEX=HALF, *
FEATURE=GPKUP, *
ISTATUS=INACTIVE, *
LNCTL=BSC, *
MODETAB=AMODETAB, *
NEGPOLP=.2, *
NPACOLL=YES, *
PAUSE=0, *
POLIMIT=(10,QUEUE), *
POLLED=YES, *
REPLYTO=3, *
RETRIES=(5,5,5), *
SERVLIM=15, *
SERVPRI=OLD, *
SESSION=32, *
TRANSFR=8, *
USSTAB=AUSSTAB

*
A03B02 LINE ADDRESS=002
*
A03C021 CLUSTER CUTYPE=3271,GPOLL=40407F7F,LOGTAB=INTERP
*
A03T0211 TERMINAL TERM=3277,ADDR=60604040,POLL=40404040
A03T0212 TERMINAL TERM=3277,ADDR=6060C1C1,POLL=4040C1C1
A03T0213 TERMINAL TERM=3277,ADDR=6060C2C2,POLL=4040C2C2
A03T0214 TERMINAL TERM=3277,ADDR=6060C3C3,POLL=4040C3C3
A03T0215 TERMINAL TERM=3277,ADDR=6060C4C4,POLL=4040C4C4
A03T0216 TERMINAL TERM=3277,ADDR=6060C5C5,POLL=4040C5C5
A03T0217 TERMINAL TERM=3277,ADDR=6060C6C6,POLL=4040C6C6
A03T0218 TERMINAL TERM=3277,ADDR=6060C7C7,POLL=4040C7C7
A03T0219 TERMINAL TERM=3277,ADDR=6060C8C8,POLL=4040C8C8
A03T021A TERMINAL TERM=3277,ADDR=6060C9C9,POLL=4040C9C9
A03T021B TERMINAL TERM=3277,ADDR=60604A4A,POLL=40404A4A
A03T021C TERMINAL TERM=3277,ADDR=60604B4B,POLL=40404B4B
A03T021D TERMINAL TERM=3277,ADDR=60604C4C,POLL=40404C4C
A03T021E TERMINAL TERM=3277,ADDR=60604D4D,POLL=40404D4D
A03T021F TERMINAL TERM=3277,ADDR=60604E4E,POLL=40404E4E
*
A03C022 CLUSTER CUTYPE=3271,GPOLL=C1C17F7F,LOGTAB=INTERP
*
A03T0221 TERMINAL TERM=3277,ADDR=61614040,POLL=C1C14040
A03T0222 TERMINAL TERM=3277,ADDR=6161C1C1,POLL=C1C1C1C1
A03T0223 TERMINAL TERM=3277,ADDR=6161C2C2,POLL=C1C1C2C2
A03T0224 TERMINAL TERM=3277,ADDR=6161C3C3,POLL=C1C1C3C3
A03T0225 TERMINAL TERM=3277,ADDR=6161C4C4,POLL=C1C1C4C4
A03T0226 TERMINAL TERM=3277,ADDR=6161C5C5,POLL=C1C1C5C5
A03T0227 TERMINAL TERM=3277,ADDR=6161C6C6,POLL=C1C1C6C6
```

Figure A-2 (Part 8 of 32). NCP A03 Sample Generation Definition



## NCP A03 Sample Generation Definition

```

A03T0228 TERMINAL TERM=3277,ADDR=6161C7C7,POLL=C1C1C7C7
A03T0229 TERMINAL TERM=3277,ADDR=6161C8C8,POLL=C1C1C8C8
A03T022A TERMINAL TERM=3277,ADDR=6161C9C9,POLL=C1C1C9C9
A03T022B TERMINAL TERM=3277,ADDR=61614A4A,POLL=C1C14A4A
A03T022C TERMINAL TERM=3277,ADDR=61614B4B,POLL=C1C14B4B
A03T022D TERMINAL TERM=3277,ADDR=61614C4C,POLL=C1C14C4C
A03T022E TERMINAL TERM=3277,ADDR=61614D4D,POLL=C1C14D4D
A03T022F TERMINAL TERM=3277,ADDR=61614E4E,POLL=C1C14E4E
*
*****
*      NPA DEFINITION - NETWORK PERFORMANCE ANALYZER      *
*****
*
A03NPAG  GROUP LNCTL=SDLC,                                *
          NPARSC=YES,                                    *
          VIRTUAL=YES
*
A03NPAL  LINE
*
A03NPAP  PU
*
A03NPLU1 LU
A03NPLU2 LU
A03NPLU3 LU
A03NPLU4 LU
A03NPLU5 LU
A03NPLU6 LU
A03NPLU7 LU
A03NPLU8 LU
*
*****
*      ADDRESSES 34, 35 AND 20      : SDLC FDX LEASED LINES      *
*****
*
A03BNNA  GROUP ANS=CONT,                                  *
          AVGPB=125,                                      *
          DIAL=NO,                                        *
          DUPLEX=FULL,                                    *
          IRETRY=YES,                                    *
          ISTATUS=INACTIVE,                              *
          LNCTL=SDLC,                                    *
          MAXDATA=265,                                    *
          MAXOUT=7,                                       *
          MODETAB=AMODETAB,                              *
          NRZI=YES,                                       *
          NPACOLL=YES,                                    *
          PACING=0,                                       *
          PASSLIM=8,                                      *

```

Figure A-2 (Part 9 of 32). NCP A03 Sample Generation Definition

## NCP A03 Sample Generation Definition

```

                PUTYPE=2,                *
                REPLYTO=3,               *
                RETRIES=(,3,5),          *
                SERVLIM=10,              *
                SPEED=56000,             *
                TYPE=NCP,                *
                USSTAB=AUSSTAB
*
*****
* ADDRESS 34 = 9.6 FDX ( DR CAPABLE ) WITH 5 DLU & 5 ILU EACH *
*****
A03S34  LINE ADDRESS=(034,FULL),        *
                CLOCKNG=EXT,            *
                DUPLEX=FULL,            *
                ISTATUS=ACTIVE,         *
                MAXPU=25,                *
                MODETAB=AMODETAB,       *
                NRZI=YES,                *
                PACING=7,                *
                PUDR=YES,                *
                RETRIES=(5,5,5),        *
                SPEED=9600
                SERVICE MAXLIST=25
A03P34A PU ADDR=C1,                    *
                XID=YES
A03D34A1 LU LOCADDR=01
A03D34A2 LU LOCADDR=02
A03D34A3 LU LOCADDR=03
A03D34A4 LU LOCADDR=04
A03D34A5 LU LOCADDR=05
*
A03I34A1 LU LOCADDR=0,RESSCB=5
A03I34A2 LU LOCADDR=0,RESSCB=5
A03I34A3 LU LOCADDR=0,RESSCB=5
A03I34A4 LU LOCADDR=0,RESSCB=5
A03I34A5 LU LOCADDR=0,RESSCB=5
*
*****
* ADDRESS 35 = 9.6 FDX ( DR CAPABLE ) WITH 5 DLU & 5 ILU EACH *
*****
A03S35  LINE ADDRESS=(035,FULL),        *
                CLOCKNG=EXT,            *
                DUPLEX=FULL,            *
                ISTATUS=ACTIVE,         *
                MAXPU=25,                *
                MODETAB=AMODETAB,       *
                NRZI=YES,                *
                PACING=7,                *

```

Figure A-2 (Part 10 of 32). NCP A03 Sample Generation Definition

## NCP A03 Sample Generation Definition

```

                PUDR=YES,
                RETRIES=(5,5,5),
                SPEED=9600
                SERVICE MAXLIST=25
A03P35A PU ADDR=C1,
                XID=YES
A03D35A1 LU LOCADDR=01
A03D35A2 LU LOCADDR=02
A03D35A3 LU LOCADDR=03
A03D35A4 LU LOCADDR=04
A03D35A5 LU LOCADDR=05
*
A03I35A1 LU LOCADDR=0,RESSCB=5
A03I35A2 LU LOCADDR=0,RESSCB=5
A03I35A3 LU LOCADDR=0,RESSCB=5
A03I35A4 LU LOCADDR=0,RESSCB=5
A03I35A5 LU LOCADDR=0,RESSCB=5
*
*****
* ADDRESS 20 = 1 PU WITH 1 DLU, 2 PUS WITH 10 DLU & 2 ILU *
*****
A03S20 LINE ADDRESS=(020,FULL),
                CLOCKNG=EXT,
                DUPLEX=FULL,
                ISTATUS=ACTIVE,
                MAXPU=25,
                MODETAB=AMODETAB,
                NRZI=YES,
                PACING=7,
                RETRIES=(5,5,5),
                SPEED=56000
                SERVICE MAXLIST=25
A03P20A PU ADDR=C1,
                XID=YES
A03T20A1 LU LOCADDR=01
*
A03P20B PU ADDR=C2,
                ANS=CONT,
                IRETRY=YES,
                ISTATUS=INACTIVE,
                LOGTAB=INTERP,
                MAXDATA=256,
                MAXOUT=7,
                MODETAB=AMODETAB,
                PASSLIM=8,
                PUDR=YES,
                PUTYPE=2,
                USSTAB=AUSSTAB,
                XID=YES
*

```

Figure A-2 (Part 11 of 32). NCP A03 Sample Generation Definition

## NCP A03 Sample Generation Definition

```

A03D20B1 LU LOCADDR=1
A03D20B2 LU LOCADDR=2
A03D20B3 LU LOCADDR=3
A03D20B4 LU LOCADDR=4
A03D20B5 LU LOCADDR=5
A03D20B6 LU LOCADDR=6
A03D20B7 LU LOCADDR=7
A03D20B8 LU LOCADDR=8
A03D20B9 LU LOCADDR=9
A03D20BA LU LOCADDR=10
A03I20B1 LU LOCADDR=0,RESSCB=5
A03I20B2 LU LOCADDR=0,RESSCB=5
*
A03P20C PU ADDR=C3, *
          ANS=CONT, *
          IRETRY=YES, *
          ISTATUS=INACTIVE, *
          LOGTAB=INTERP, *
          MAXDATA=256, *
          MAXOUT=7, *
          MODETAB=AMODETAB, *
          PASSLIM=8, *
          PUDR=YES, *
          PUTYPE=2, *
          USSTAB=AUSSTAB, *
          XID=YES *
*
A03D20C1 LU LOCADDR=1
A03D20C2 LU LOCADDR=2
A03D20C3 LU LOCADDR=3
A03D20C4 LU LOCADDR=4
A03D20C5 LU LOCADDR=5
A03D20C6 LU LOCADDR=6
A03D20C7 LU LOCADDR=7
A03D20C8 LU LOCADDR=8
A03D20C9 LU LOCADDR=9
A03D20CA LU LOCADDR=10
A03I20C1 LU LOCADDR=0,RESSCB=5
A03I20C2 LU LOCADDR=0,RESSCB=5
*
*
*****
* MULTIDROP SUBAREA LINKS TO IFWA04 - SECONDARY SIDE *
*****
A03GMUL1 GROUP LNCTL=SDLC, *
          MODE=SEC *
A03S03 LINE ADDRESS=(003,FULL), *
          CLOCKNG=EXT, *
          MONLINK=YES, *
          NRZI=YES, *

```

Figure A-2 (Part 12 of 32). NCP A03 Sample Generation Definition

## NCP A03 Sample Generation Definition

```

                PAUSE=0.2,
                SPEED=2400,
                TADDR=02,
                TRANSFR=20
                SERVICE ORDER=(A03P03A)
A03P03A  PU ANS=CONT,
                IRETRY=YES,
                NETID=NETA,
                NPACOLL=YES,
                PUTYPE=4,
                TGN=1
*
A03S04  LINE ADDRESS=(004,FULL),
                CLOCKNG=EXT,
                MONLINK=YES,
                NRZI=YES,
                PAUSE=0.2,
                SPEED=2400,
                TADDR=03,
                TRANSFR=20
                SERVICE ORDER=(A03P04A)
A03P04A  PU ANS=CONT,
                IRETRY=YES,
                NETID=NETA,
                NPACOLL=YES,
                PUTYPE=4,
                TGN=1
*
*
*
*
*****
*      GROUP FOR LEASED PERIPHERAL LINES      *
*****
*
A03BNN1  GROUP ANS=CONT,
                AVGPB=125,
                DIAL=NO,
                DUPLEX=FULL,
                IRETRY=YES,
                ISTATUS=INACTIVE,

```

Figure A-2 (Part 13 of 32). NCP A03 Sample Generation Definition

## NCP A03 Sample Generation Definition

```

LNCTL=SDLC,
MAXDATA=265,
MAXOUT=7,
MODETAB=AMODETAB,
NRZI=YES,
NPACOLL=YES,
PACING=0,
PASSLIM=7,
PUTYPE=2,
REPLYTO=3,
RETRIES=(,3,5),
SERVLIM=15,
TYPE=NCP,
USSTAB=AUSSTAB
*
*****
* ADDRESS 01 2 PU'S ( DR CAPABLE ), 5 DLU, 5 ILU *
*****
A03S01 LINE ADDRESS=(001,FULL),
CLOCKNG=EXT,
DUPLEX=FULL,
ISTATUS=ACTIVE,
MAXOUT=127,
MAXPU=25,
MODETAB=AMODETAB,
MODULO=128,
NRZI=YES,
PACING=7,
PUDR=YES,
RETRIES=(5,5,5),
SPEED=9600
SERVICE MAXLIST=50
A03P01A PU ADDR=C1,
XID=YES
A03D011A LU DLOGMOD=M23278I,
LOCADDR=01
A03D011B LU DLOGMOD=M23278I,
LOCADDR=02
A03D011C LU DLOGMOD=M3767,
LOCADDR=03
A03D011D LU DLOGMOD=M3767,
LOCADDR=04
A03D011E LU LOCADDR=05

```

Figure A-2 (Part 14 of 32). NCP A03 Sample Generation Definition

## NCP A03 Sample Generation Definition

```

*
A03I011A LU LOCADDR=0,RESSCB=18
A03I011B LU LOCADDR=0,RESSCB=18
A03I011C LU LOCADDR=0,RESSCB=18
A03I011D LU LOCADDR=0,RESSCB=18
A03I011E LU LOCADDR=0,RESSCB=18
*
A03P01B PU ADDR=C2, *
          XID=YES
A03D012A LU DLOGMOD=M23278I, *
          LOCADDR=01
A03D012B LU DLOGMOD=M23278I, *
          LOCADDR=02
A03D012C LU DLOGMOD=M3767, *
          LOCADDR=03
A03D012D LU DLOGMOD=M3767, *
          LOCADDR=04
A03D012E LU LOCADDR=05
*
A03I012A LU LOCADDR=0,RESSCB=18
A03I012B LU LOCADDR=0,RESSCB=18
A03I012C LU LOCADDR=0,RESSCB=18
A03I012D LU LOCADDR=0,RESSCB=18
A03I012E LU LOCADDR=0,RESSCB=18
*
*****
*      SUBAREA LINK:  SDLC FOR PRIMARY/SECONDARY STATION      *
*****
*
A03GPRI  GROUP ACTIVTO=60.0, *
          DIAL=NO, *
          LNCTL=SDLC, *
          MODE=PRI, *
          REPLYTO=30, *
          TYPE=NCP
*
A03GSEC  GROUP ACTIVTO=60.0, *
          DIAL=NO, *
          LNCTL=SDLC, *
          MODE=SEC, *
          TYPE=NCP
*

```

Figure A-2 (Part 15 of 32). NCP A03 Sample Generation Definition

## NCP A03 Sample Generation Definition

```
*****
*   ADDRESSES 000, 032, 033: SDLC, LEASED SUBAREA FOR DYNAMIC NETID
*****
*
A03LEAS1 GROUP ACTIVTO=60.0, *
                DIAL=NO, *
                LNCTL=SDLC, *
                MODULO=128, *
                NETID=(NETA,ANY), *
                REPLYTO=3, *
                TYPE=NCP
*
*****
*   ADDRESS 000 = SDLC, LEASED, 9.6KB FOR SNBU
*   NETID = (NETA,ANY) TO IFWC04
*****
A03S00  LINE ADDRESS=(000,FULL), *
                CLOCKNG=EXT, *
                DUPLEX=FULL, *
                ISTATUS=INACTIVE, *
                LPDATS=LPDA2, *
                MODULO=8, *
                NEWSYNC=NO, *
                NRZI=YES, *
                RETRIES=(3,5,4), *
                SDLCST=(S03PRI,S03SEC), *
                SPEED=9600, *
                TRANSFR=41
*
A03P00  PU AVGPB=256, *
                IRETRY=YES, *
                MAXOUT=7, *
                PUTYPE=4, *
                TGN=1
*
*****
*   ADDRESS 032: SDLC, LEASED, 9.6KB FOR SNBU
*   NETID = (NETA,ANY) TO IFWC04
*****
A03S32  LINE ADDRESS=(032,FULL), *
                CLOCKNG=EXT, *
                DUPLEX=FULL, *
                ISTATUS=INACTIVE, *
```

Figure A-2 (Part 16 of 32). NCP A03 Sample Generation Definition



## NCP A03 Sample Generation Definition

```

NEWSYNC=NO,
NRZI=YES,
RETRIES=(3,5,4),
SDLCST=(S03PRI,S03SEC),
SPEED=9600,
TRANSFR=41
*
*
A03P32  PU AVGPB=256,
        IRETRY=YES,
        MAXOUT=127,
        PUTYPE=4,
        TGN=1
*
*
*****
* SUBAREA LINE ADDRESS=33  FULL DUPLEX  9.6
* NETID = (NETA,ANY) TO IFWC04
*****
*
A03S33  LINE ADDRESS=(033,FULL),
        CLOCKNG=EXT,
        DUPLEX=FULL,
        IPL=NO,
        ISTATUS=INACTIVE,
        MONLINK=YES,
        NEWSYNC=NO,
        NRZI=YES,
        RETRIES=(5,5,5),
        SDLCST=(S03PRI,S03SEC),
        SPEED=9600,
        TRANSFR=41
A03P33  PU AVGPB=256,
        IRETRY=YES,
        MAXOUT=127,
        MODULO=128,
        PUTYPE=4,
        TGN=1

```

Figure A-2 (Part 17 of 32). NCP A03 Sample Generation Definition

## NCP A03 Sample Generation Definition

```
*****
* SUBAREA LINE ADDRESS=16 FULL DUPLEX 56KB *
* NETID = (NETA,ANY) TO IFWB31 *
*****
*
A03S16 LINE ADDRESS=(016,FULL), *
        CLOCKNG=EXT, *
        DUPLEX=FULL, *
        IPL=NO, *
        ISTATUS=INACTIVE, *
        MONLINK=YES, *
        NEWSYNC=NO, *
        NRZI=YES, *
        RETRIES=(5,5,5), *
        SDLCST=(S03PRI,S03SEC), *
        SPEED=56000, *
        TRANSFR=41
A03P16 PU AVGPB=256, *
        IRETRY=YES, *
        MAXOUT=127, *
        MODULO=128, *
        PUTYPE=4, *
        TGN=1
*****
* SUBAREA LINE ADDRESS=48 FULL DUPLEX 56KB *
* NETID = (NETA) TO IFWA04 *
*****
*
A03S48 LINE ADDRESS=(048,FULL), *
        CLOCKNG=EXT, *
        DUPLEX=FULL, *
        IPL=NO, *
        ISTATUS=INACTIVE, *
        MONLINK=YES, *
        NEWSYNC=NO, *
        NRZI=YES, *
        RETRIES=(5,5,5), *
        SDLCST=(S03PRI,S03SEC), *
        SPEED=56000, *
        TRANSFR=41
```

Figure A-2 (Part 18 of 32). NCP A03 Sample Generation Definition

## NCP A03 Sample Generation Definition

```

A03P48  PU AVGPB=256, *
        IRETRY=YES, *
        MAXOUT=127, *
        MODULO=128, *
        PUTYPE=4, *
        TGN=1
*****
* SUBAREA LINE ADDRESS=1028 FULL DUPLEX HPTSS *
* TO IFWA04 IN NETA *
*****
A03S128 LINE ADDRESS=(1028,FULL), *
        CLOCKNG=EXT, *
        DUPLEX=FULL, *
        IPL=NO, *
        ISTATUS=INACTIVE, *
        MONLINK=YES, *
        NEWSYNC=NO, *
        NRZI=YES, *
        RETRIES=(5,5,5), *
        SDLCST=(S03PRI,S03SEC), *
        SPEED=1544000, *
        TRANSFR=41
A03P128 PU AVGPB=256, *
        IRETRY=YES, *
        MAXOUT=127, *
        PUTYPE=4, *
        TGN=1
*
*****
* FRAME RELAY PHYSICAL LINE 052 - FULL DUPLEX 56KB TO IFWB31 052 *
*****
*
A03FRGP2 GROUP FRELAY=PHYSICAL, *
        ISTATUS=ACTIVE, *
        MAXFRAME=2106, *
        XMONLNK=YES, *
        TYPE=NCP, *
        DIAL=NO, *
        LNCTL=SDLC, *
        NPACOLL=(YES,EXTENDED), *
        PUTYPE=1

```

Figure A-2 (Part 19 of 32). NCP A03 Sample Generation Definition

## NCP A03 Sample Generation Definition

```

*
A03F52  LINE ADDRESS=(052,FULL),
        CLOCKNG=EXT,
        NRZI=NO,
        ARPTAB=(40,,NOTCANON),
        SPEED=56000
*
*
A03P52  PU ANS=CONTINUE,
        PUDR=NO,
        NPACOLL=(YES,EXTENDED),
        INNPORT=YES
*
*
FRIPPU52 PU  PUTYPE=1,
             ADDR=3A,
             P2PDEST=128.10.31.99,
             PROTOCOL=RIP,
             METRIC=1,
             INTFACE=(FRPU0052,500),
             LADDR=128.10.03.99
*
*****
* FRAME RELAY LOGICAL SUBAREA LINES FOR A03F52
*****
*
A03FRGL2 GROUP FRELAY=LOGICAL,
              ISTATUS=ACTIVE,
              MAXOUT=127,
              MODULO=128,
              NETID=(NETA,ANY),
              PHYSRSC=A03P52,
              RETRIES=(5,5,5),
              SDLCST=(S03PRI,S03SEC),
              TYPE=NCP,
              DIAL=NO,
              LNCTL=SDLC,
              LEVEL2=ECLNAVL2,
              LEVEL3=ECLNAVL3,
              LEVEL5=NCP,
              XI0=(ECLNAVXL,ECLNAVXS,ECLNAVXI,ECLNAVXK),
              LINEADD=NONE,
              NPACOLL=(YES,EXTENDED),
              PUTYPE=4,
              COMPSWP=NO,
              COMPOWN=YES
*

```

Figure A-2 (Part 20 of 32). NCP A03 Sample Generation Definition

## NCP A03 Sample Generation Definition

```

*****
* LOGICAL LINE 1 --- DLCI X'36' TALKS TO DLCI X'36' IN NCP IFWB31 *
*****
A03LL1G LINE ISTATUS=ACTIVE,MONLINK=YES,IPL=YES, *
          UACB=X$L1B
A03PL1G PU ANS=CONT, *
          PUTYPE=4, *
          TGN=1, *
          DLCI=(54,D), *
          NPACOLL=NO
*
*****
* FRAME RELAY PHYSICAL LINE 1036 - FULL DUPLEX HPTSS *
*****
A03FRGP1 GROUP FRELAY=PHYSICAL, *
             ISTATUS=ACTIVE, *
             MAXFRAME=2106, *
             TYPE=NCP, *
             XMONLNK=YES, *
             DIAL=NO, *
             LNCTL=SDLC, *
             NPACOLL=(YES,EXTENDED), *
             PUTYPE=1
*
A03F1036 LINE ADDRESS=(1036,FULL), *
             CLOCKNG=EXT, *
             NRZI=NO, *
             SPEED=1544000
A03P1036 PU ANS=CONTINUE, *
             ERRORT=(3,4), *
             LMI=CCITT, *
             SPOLL=6, *
             TIMERS=(10,15), *
             PUDR=NO, *
             NPACOLL=(YES,EXTENDED), *
             INNPORT=YES
*
*****
* FRAME RELAY LOGICAL SUBAREA LINES FOR A03F1036 *
*****
A03FRGL1 GROUP FRELAY=LOGICAL, *
             ISTATUS=ACTIVE, *
             MAXOUT=127, *
             MODULO=128, *
             NETID=(NETA,ANY), *
             PHYSRSC=A03P1036, *
             RETRIES=(5,5,5), *

```

Figure A-2 (Part 21 of 32). NCP A03 Sample Generation Definition

## NCP A03 Sample Generation Definition

```
SDLCST=(S03PRI,S03SEC), *
TYPE=NCP, *
DIAL=NO, *
LNCTL=SDLC, *
LEVEL2=ECLNAVL2, *
LEVEL3=ECLNAVL3, *
LEVEL5=NCP, *
XIO=(ECLNAVXL,ECLNAVXS,ECLNAVXI,ECLNAVXK), *
LINEADD=NONE, *
NPACOLL=(YES,EXTENDED), *
PUTYPE=4, *
COMPSWP=NO, *
COMPOWN=YES
*
*****
* LOGICAL LINE 1 --- DLCI X'1E' TALKS TO DLCI X'1F' IN NCP IFWB31 *
*****
A03LL1A LINE ISTATUS=ACTIVE,MONLINK=YES,IPL=YES, *
        UACB=X$L2B
A03PL1A PU ANS=CONTINUE, *
        PUTYPE=4, *
        TGN=1, *
        DLCI=(30,D), *
        NPACOLL=NO
*
*****
* LOGICAL LINE 2 --- DLCI X'2E' TALKS TO DLCI X'2F' IN NCP IFWB31 *
*****
A03LL1B LINE ISTATUS=ACTIVE,MONLINK=YES,IPL=YES, *
        UACB=X$L3B
A03PL1B PU ANS=CONTINUE, *
        PUTYPE=4, *
        TGN=1, *
        DLCI=(46,D), *
        NPACOLL=NO
*
*****
* LOGICAL LINE 3 --- DLCI X'3E' TALKS TO DLCI X'3F' IN NCP IFWB31 *
*****
A03LL1C LINE ISTATUS=ACTIVE,MONLINK=YES,IPL=YES, *
        UACB=X$L4B
A03PL1C PU ANS=CONTINUE, *
        PUTYPE=4, *
        TGN=1, *
        DLCI=(62,D), *
        NPACOLL=NO
*
*
```

Figure A-2 (Part 22 of 32). NCP A03 Sample Generation Definition

## NCP A03 Sample Generation Definition

```

*****
*      NCP/TOKEN RING INTERCONNECT PHYSICAL LINES      *
*****
*
A03NTR1  GROUP ANS=CONTINUE,                               *
          ADAPTER=TIC2,                                    *
          ECLTYPE=(PHYSICAL,ANY),                          *
          MAXTSL=16732,                                    *
          RCVBUFC=32000,                                    *
          RETRIES=(20,5,5),                                *
          USSTAB=AUSSTAB,                                  *
          XID=NO,                                          *
          TYPE=NCP,                                        *
          DIAL=NO,                                         *
          LNCTL=SDLC,                                      *
          LEVEL2=ECLNARL2,                                 *
          LEVEL3=ECLNARL3,                                 *
          LEVEL5=NCP,                                      *
          TIMER=(ECLNART1,,ECLNART2,ECLNART3),           *
          XIO=(ECLNARXL,ECLNARXS,ECLNARXI,ECLNARXK),     *
          USERID=(5668854,ECLRBDT,NORECMS,,ECLNMVT),    *
          SPEED=9600,                                      *
          NPACOLL=NO,                                      *
          PUTYPE=1,                                        *
          PUDR=NO,                                         *
          COMPTAD=YES,                                     *
          COMPSWP=YES,                                     *
          COMPOWN=YES
*****
*      ADDRESS 1088:  NTRI PHYSICAL LINE - SUBAREA/PERIPHERAL      *
*****
*
A03TR88  LINE ADDRESS=(1088,FULL),                          *
          INTERFACE=TR88,                                  *
          LOCADD=400000000331,                             *
          PORTADD=1,                                       *
          TRSPEED=16,                                       *
          UACB=(X$P1AX,X$P1AR)
*
*      PU FOR SNA TRAFFIC
*
A03PU88  PU ADDR=01,                                       *
          NETWORK=SNA,                                     *
          PUTYPE=1,                                        *
          INNPORT=YES
*
*      PU FOR IP TRAFFIC
*
A03PU88A PU ADDR=02,                                       *
          ARPTAB=(1000,20,NOTCANON),                      *
          NETWORK=IP,                                      *
          PUTYPE=1,                                        *
          INNPORT=YES

```

Figure A-2 (Part 23 of 32). NCP A03 Sample Generation Definition

## NCP A03 Sample Generation Definition

```
*
*****
* ADDRESS 1089: NTRI PHYSICAL LINE - PERIPHERAL - V6R1 DUP TIC *
*****
*
A03NTR2 GROUP ECLTYPE=(PHYSICAL,PER), *
          ANS=CONTINUE, *
          RETRIES=(20,5,5), *
          USSTAB=AUSSTAB, *
          XID=NO, *
          TYPE=NCP, *
          DIAL=NO, *
          LNCTL=SDLC, *
          LEVEL2=ECLNARL2, *
          LEVEL3=ECLNARL3, *
          LEVEL5=NCP, *
          TIMER=(ECLNART1,,ECLNART2,ECLNART3), *
          XIO=(ECLNARXL,ECLNARXS,ECLNARXI,ECLNARXK), *
          USERID=(5668854,ECLRBDT,NORECMS,,ECLNMVT), *
          SPEED=9600, *
          NPACOLL=NO, *
          PUTYPE=1, *
          PUDR=NO, *
          COMPTAD=YES, *
          COMPSWP=YES, *
          COMPOWN=YES
*
A03TR89 LINE ADDRESS=(1089,FULL), *
          ADAPTER=TIC2, *
          LOCADD=400000FEDCBA, *
          PORTADD=2, *
          TRSPEED=16, *
          UACB=(X$P2AX,X$P2AR)
*
A03PU89 PU ADDR=01
*****
* ADDRESS 1092: NTRI PHYSICAL LINE - PERIPHERAL - DUP TIC - HEX ADDR *
*****
*
A03TR92 LINE ADDRESS=(1092,FULL), *
          ADAPTER=TIC2, *
          LOCADD=400000ABCDEF, *
          PORTADD=5, *
          TRSPEED=16, *
          UACB=(X$P3AX,X$P3AR)
*
A03PU92 PU ADDR=01
```

Figure A-2 (Part 24 of 32). NCP A03 Sample Generation Definition



## NCP A03 Sample Generation Definition

```

*
*****
* ADDRESS 1093: NTRI PHYSICAL LINE - PERIPHERAL - DUP TIC - HEX ADDR *
*****
A03TR93  LINE ADDRESS=(1093,FULL),
          ADAPTER=TIC2,
          LOCADD=400000ABCDEF,
          PORTADD=6,
          TRSPEED=4,
          UACB=(X$P4AX,X$P4AR)
*
*
A03PU93  PU ADDR=01
*
*****
*      NTRI PERIPHERAL LOGICAL LINES
*****
*
A03NTRL1 GROUP ECLTYPE=LOGICAL,
               ANS=CONTINUE,
               AUTOGEN=50,
               CALL=INOUT,
               MODETAB=AMODETAB,
               NPACOLL=(YES,EXTENDED),
               PHYSPORT=NONE,
               PHYRSC=NONE,
               RETRIES=(10,4,10,6),
               RNRLIMIT=3,
               USSTAB=AUSSTAB,
               XMITDLY=NONE,
               TYPE=NCP,
               DIAL=YES,
               LNCTL=SDLC,
               LEVEL2=ECLNAV2,
               LEVEL3=ECLNAV3,
               LEVEL5=NCP,
               XIO=(ECLNAVXL,ECLNAVXS,ECLNAVXI,ECLNAVXK),
               USERID=(5668854,ECLVBDT,NORECMS,,ECLNMVT),
               LINEAUT=YES,
               PUTYPE=2,
               COMPOWN=YES
*
               LINEADD=NONE,

```

Figure A-2 (Part 25 of 32). NCP A03 Sample Generation Definition

## NCP A03 Sample Generation Definition

```

*****
*      NTRI SUBAREA LOGICAL CONNECTIONS FOR 1088      *
*      NETID = (NETA,ANY) TO IFWB31 1092             *
*****
*
A03NTRL3 GROUP ECLTYPE=(LOGICAL,SUBAREA),           *
               ANS=CONTINUE,                         *
               MODETAB=AMODETAB,                     *
               NETID=(NETA,ANY),                     *
               PHYPORT=1,                             *
               PHYRSC=A03PU88,                       *
               SDLCST=(S03PRI,S03SEC),               *
               USSTAB=AUSSTAB,                       *
               TYPE=NCP,                             *
               DIAL=NO,                              *
               LNCTL=SDLC,                           *
               LEVEL2=ECLNAVL2,                      *
               LEVEL3=ECLNAVL3,                      *
               LEVEL5=NCP,                           *
               XIO=(ECLNAVXL,ECLNAVXS,ECLNAVXI,ECLNAVXK), *
               USERID=(5668854,ECLVBDT,NORECMS,,ECLNMVT), *
               LINEADD=NONE,                         *
               NPACOLL=NO,                           *
               PUTYPE=4,                              *
               COMPOWN=YES,                           *
               RETRIES=(6,0,0,6)
*
A03LG1A  LINE TGN=1,                                *
           UACB=X$L51A
*
A03PG1A  PU ADDR=04400000017335
*
*****
*      ETHERNET ADAPTER INTERFACES                    *
*****
*
A03ETH   GROUP ETHERNET=PHYSICAL,                   *
           DIAL=NO,                                 *
           ISTATUS=ACTIVE,                          *
           LNCTL=SDLC,                               *
           VIRTUAL=NO
*****
A03E170  LINE ADDRESS=(1070,FULL), * INTERFACE TO ETHERNET2 (ETH2) *
           ANS=CONT,                                *
           FRAMECNT=(100000,5000),                  *
           INTFACE=ETH2,                             *
           LANTYPE=DYNAMIC
*
A03P170  PU ANS=CONT,                                *
           ARPTAB=(2000,20),                         *
           INNPORT=YES,                              *
           PUTYPE=1,                                  *
           NPACOLL=NO,                               *
           LPDA=BLOCK

```

Figure A-2 (Part 26 of 32). NCP A03 Sample Generation Definition

## NCP A03 Sample Generation Definition

```
*****
A03E171 LINE ADDRESS=(1071,FULL), * INTERFACE TO ETHERNET3 (ETH3) *
        ANS=CONT, *
        FRAMECNT=(100000,5000), *
        INTFACE=ETH3, *
        LANTYPE=DYNAMIC
*
A03P171 PU ANS=CONT, *
        ARPTAB=(2000,20), *
        INNPOR=YES, *
        PUTYPE=1, *
        NPACOLL=NO, *
        LPDA=BLOCK
*
*****
* NCST IP INTERFACES *
*****
*
A03NCSTG GROUP NCST=IP, LNCTL=SDLC, ANS=CONT, ISTATUS=ACTIVE, *
        VIRTUAL=YES
A03NCSTL LINE LINEFVT=CXSXFVT, *
        PUFVT=CXSXFVT, *
        LUFVT=(CXSXFVT,CXSXFVT), *
        LINECB=CXSXLNK
A03NCSTP PU PUTYPE=2, *
        PUCB=CXSP0000
*****
A03NCSA7 LU INTFACE=IOWNER, REMLU=SNALA17, * TO A17 *
        LUCB=(CXSL0000,CXSS0000), *
        LOCADDR=1
```

Figure A-2 (Part 27 of 32). NCP A03 Sample Generation Definition

## NCP A03 Sample Generation Definition

```

*****
A03NCS1P LU INTFACE=INTF2,REMLU=(B31NCS1P),          * TO B31 *
          LUCB=(CXSL0001,CXSS0001),                  *
          LOCADDR=2
A03NCS1B LU INTFACE=INTF2,REMLU=(B31NCS1B),          * TO B31 *
          LUCB=(CXSL0002,CXSS0002),                  *
          LOCADDR=3
*****
A03NCSA1 LU INTFACE=HOSTA01,REMLU=SNALA01,           * TO A01 *
          LUCB=(CXSL0003,CXSS0003),                  *
          LOCADDR=4
*
*****
*   CHANNEL ADAPTER DEFINITIONS                       *
*****
*
A03CA1  GROUP LNCTL=CA,                               *
          CA=TYPE7,                                   *
          NCPCA=ACTIVE,                              *
          TIMEOUT=180.0
*
*****
*   CA ADDR - 08          PHYSICAL PORT 1            *
*****
*
A03CP1  LINE ADDRESS=P1,                             *
          CASDL=420,                                  *
          DELAY=0.2
*
A03PP1A PU PUTYPE=5,                                 *
          TGN=1
*
*****
*   CA ADDR - 10          PHYSICAL PORT 3            *
*   USED TO ESTABLISH CP-CP SESSIONS TO A500        *
*   SEE ALSO MEMBER LCL011 IN VTAMLST               *
*****
*
A03CP3  LINE ADDRESS=P3,                             *
          CASDL=420,                                  *
          DELAY=0.2
*
A03PP3A PU PUTYPE=2,                                 *
          CONNTYPE=APPN,CPCP=YES
*

```

Figure A-2 (Part 28 of 32). NCP A03 Sample Generation Definition

## NCP A03 Sample Generation Definition

```

*****
*   CA ADDR - 00           PHYSICAL PORT 5           *
*   USED TO ESTABLISH CP-CP SESSIONS TO A82         *
*   SEE ALSO MEMBER LCL013 IN VTAMLST              *
*****
*
A03CP5  LINE ADDRESS=P5,                             *
        CASDL=420,                                   *
        DELAY=0.2,                                   *
        NETID=NETA
*
A03PP5A PU PUTYPE=2,                                 *
        CONNTYPE=APPN,CPCP=YES
*
*****
*   CA ADDR - 02           PHYSICAL PORT 7           *
*****
*
A03CP7  LINE ADDRESS=P7,                             *
        CASDL=420,                                   *
        DELAY=0.2,                                   *
        NETID=NETB
*
A03PP7A PU PUTYPE=5,                                 *
        TGN=1
*
*****
*   NON-NATIVE NETWORK DEFINITIONS FOR NETB        *
*****
*
NETB    NETWORK SUBAREA=03,SALIMIT=2047,NETID=NETB,  *
        VRTIMER0=(180,,50),VRTIMER1=(180,,50),VRTIMER2=(180,,50)
*
        GWNAU NETID=NETA,NAME=A01N,NUMSESS=5,ELEMENT=1
        GWNAU NETID=NETA,NAME=A02N,NUMSESS=5,ELEMENT=2
        GWNAU NETID=NETA,NAME=A17N,NUMSESS=5,ELEMENT=3
        GWNAU NETID=NETA,NAME=A81N,NUMSESS=5,ELEMENT=4
        GWNAU NETID=NETA,NAME=A500N,NUMSESS=5,ELEMENT=5
        GWNAU NETID=NETC,NAME=C01N,NUMSESS=5,ELEMENT=6
*
        GWNAU NUMADDR=600
*
*****
*   PATH DECK FOR NON-NATIVE NETB                  *
*****
*
        PATH DESTSA=1,                               *
        ER0=(1,1),ER2=(1,1),ER4=(1,1),ER6=(1,1),   *
        ER1=(31,1),ER3=(31,1),ER5=(31,1),ER7=(31,1), *
        VR0=0,                                       *
        VRPWS00=(1,3),VRPWS01=(1,3),VRPWS02=(1,3), *
        VR1=1,                                       *

```

Figure A-2 (Part 29 of 32). NCP A03 Sample Generation Definition

## NCP A03 Sample Generation Definition

```

VRPWS10=(2,6),VRPWS11=(2,6),VRPWS12=(2,6),      *
VR2=2,                                             *
VRPWS20=(2,6),VRPWS21=(2,6),VRPWS22=(2,6),      *
VR3=3,                                             *
VRPWS30=(2,6),VRPWS31=(2,6),VRPWS32=(2,6),      *
VR4=4,                                             *
VRPWS40=(3,9),VRPWS41=(3,9),VRPWS42=(3,9),      *
VR5=5,                                             *
VRPWS50=(3,9),VRPWS51=(3,9),VRPWS52=(3,9),      *
VR6=6,                                             *
VRPWS60=(3,9),VRPWS61=(3,9),VRPWS62=(3,9),      *
VR7=7,                                             *
VRPWS70=(3,9),VRPWS71=(3,9),VRPWS72=(3,9)
*
PATH DESTSA=31,                                   *
ER0=(31,1),ER2=(31,1),ER4=(31,1),ER6=(31,1),    *
ER1=(31,1),ER3=(31,1),ER5=(31,1),ER7=(31,1),    *
VR0=0,                                             *
VRPWS00=(1,3),VRPWS01=(1,3),VRPWS02=(1,3),      *
VR1=1,                                             *
VRPWS10=(2,6),VRPWS11=(2,6),VRPWS12=(2,6),      *
VR2=2,                                             *
VRPWS20=(2,6),VRPWS21=(2,6),VRPWS22=(2,6),      *
VR3=3,                                             *
VRPWS30=(2,6),VRPWS31=(2,6),VRPWS32=(2,6),      *
VR4=4,                                             *
VRPWS40=(3,9),VRPWS41=(3,9),VRPWS42=(3,9),      *
VR5=5,                                             *
VRPWS50=(3,9),VRPWS51=(3,9),VRPWS52=(3,9),      *
VR6=6,                                             *
VRPWS60=(3,9),VRPWS61=(3,9),VRPWS62=(3,9),      *
VR7=7,                                             *
VRPWS70=(3,9),VRPWS71=(3,9),VRPWS72=(3,9)
*
PATH DESTSA=(75,1028),                            *
ER0=(31,1),ER2=(31,1),ER4=(31,1),ER6=(31,1),    *
ER1=(31,1),ER3=(31,1),ER5=(31,1),ER7=(31,1),    *
VR0=0,                                             *
VRPWS00=(1,3),VRPWS01=(1,3),VRPWS02=(1,3),      *
VR1=1,                                             *
VRPWS10=(2,6),VRPWS11=(2,6),VRPWS12=(2,6),      *
VR2=2,                                             *
VRPWS20=(2,6),VRPWS21=(2,6),VRPWS22=(2,6),      *
VR3=3,                                             *
VRPWS30=(2,6),VRPWS31=(2,6),VRPWS32=(2,6),      *
VR4=4,                                             *

```

Figure A-2 (Part 30 of 32). NCP A03 Sample Generation Definition

## NCP A03 Sample Generation Definition

```

VRPWS40=(3,9),VRPWS41=(3,9),VRPWS42=(3,9),      *
VR5=5,                                             *
VRPWS50=(3,9),VRPWS51=(3,9),VRPWS52=(3,9),      *
VR6=6,                                             *
VRPWS60=(3,9),VRPWS61=(3,9),VRPWS62=(3,9),      *
VR7=7,                                             *
VRPWS70=(3,9),VRPWS71=(3,9),VRPWS72=(3,9)
*
*****
*      NON-NATIVE NETWORK DEFINITIONS FOR MODEL/DYNAMIC NETWORKS      *
*****
*
MODEL  NETWORK SUBAREA=31,COPIES=3,SALIMIT=255,    *
        VRTIMERO=(180,,50),VRTIMER1=(180,,50),VRTIMER2=(180,,50)
*
        GWNAU NETID=NETA,NAME=A01N,NUMSESS=5,ELEMENT=1
        GWNAU NETID=NETA,NAME=A02N,NUMSESS=5,ELEMENT=2
        GWNAU NETID=NETA,NAME=A17N,NUMSESS=5,ELEMENT=3
        GWNAU NETID=NETA,NAME=A81N,NUMSESS=5,ELEMENT=4
        GWNAU NETID=NETA,NAME=A500N,NUMSESS=5,ELEMENT=5
        GWNAU NETID=NETB,NAME=B01N,NUMSESS=5,ELEMENT=6
        GWNAU NETID=NETB,NAME=B128N,NUMSESS=5,ELEMENT=7
*
        GWNAU NUMADDR=600
*
*****
*      PATH DECK FOR MODEL/DYNAMIC NETWORKS      *
*****
        PATH DESTSA=1,                               *
          ER0=(4,1,5000,5000,5000,20000),           *
          ER1=(3,1,5000,5000,5000,20000),           *
          VR0=1,                                       *
          VRPWS00=(2,6),VRPWS01=(2,6),VRPWS02=(2,6), *
          VR1=0,                                       *
          VRPWS10=(2,6),VRPWS11=(2,6),VRPWS12=(2,6)
        PATH DESTSA=3,                               *
          ER0=(3,1),ER1=(4,1),                       *
          VR0=0,                                       *
          VRPWS00=(1,3),VRPWS01=(1,3),VRPWS02=(1,3), *
          VR1=1,                                       *
          VRPWS10=(3,9),VRPWS11=(3,9),VRPWS12=(3,9)
        PATH DESTSA=4,                               *
          ER0=(4,1),ER1=(3,1),                       *
          VR0=0,                                       *
          VRPWS00=(1,3),VRPWS01=(1,3),VRPWS02=(1,3), *
          VR1=1,                                       *
          VRPWS10=(3,9),VRPWS11=(3,9),VRPWS12=(3,9)
*

```

Figure A-2 (Part 31 of 32). NCP A03 Sample Generation Definition

## NCP A03 Sample Generation Definition

```
*****
*   IP ROUTING DEFINITIONS   *
*****
*
*   IP OWNER IDENTIFICATION
*
*       IPOWNER INTERFACE=IPOWNER,HOSTADDR=94.0.0.1,NUMROUTE=(25,25,25)
*
*   IP ADDRESSES ASSIGNED TO LOCAL NCP INTERFACES
*
*       NCST INTERFACES
*
*       IPLOCAL LADDR=94.0.0.99,INTERFACE=IPOWNER,METRIC=1,           *
*           P2PDEST=94.0.0.1,PROTOCOL=RIP
*       IPLOCAL LADDR=95.0.0.99,INTERFACE=HOSTA01,METRIC=1,         *
*           P2PDEST=95.0.0.1,PROTOCOL=RIP
*       IPLOCAL LADDR=128.81.0.98,INTFACE=INTF2,METRIC=1,          *
*           P2PDEST=128.81.0.99,PROTOCOL=RIP
*
*       TOKEN RING INTERFACES
*
*       IPLOCAL LADDR=128.81.0.94,INTFACE=TR88,METRIC=1,           *
*           PROTOCOL=RIP
*
*       ETHERNET INTERFACE CHARACTERISTICS
*
*       IPLOCAL LADDR=96.0.0.99,INTERFACE=ETH2,METRIC=1,PROTOCOL=RIP
*       IPLOCAL LADDR=128.81.0.96,INTFACE=ETH3,METRIC=1,PROTOCOL=RIP
*
*****
*   NCP GENEND MACRO - END OF GEN   *
*****
*
*   GENEND   GENEND
```

Figure A-2 (Part 32 of 32). NCP A03 Sample Generation Definition





## NCP A04 Sample Generation Definition

```
* 2304 ESCON PHYSICAL LINE - LOGICAL LINES S2L1 - S2L4
* 2371 LEASED RVX SDLC 9.6KB SUBAREA LINE TO A31NCP LINE 2370
* 2373 SWITCHED MANUAL DIAL RVX SDLC 9.6KB TO A31NCP LINE 2372
* 2378 SWITCHED RVX CASUAL CONNECTION TO A31NCP LINE 2377
* 2380 SWITCHED RVX SDLC 1200BPS - V.25 BIS TO A31NCP LINE 2379
* 2436 LEASED RVX SDLC 56KB SUBAREA LINE TO A31NCP LINE 2432
* 2444 LEASED RVX 56KB PERIPHERAL - CASUAL CONN - A31NCP LINE 2440
* 2528 LEASED RVX SDLC T1 SUBAREA LINE TO A31NCP LINE 2496
* 2464 FRAME RELAY SUBAREA ODLG LINE TO A31NCP LINE 2468
* 2688 ISDN INTERFACE
* 2689 OR 2690 ISDN B CHANNELS USED FOR SUBAREA LINE TO
*      A31NCP LINE 2721 OR 2722 AND PERIPHERAL CONNECTIONS
*
*
*      OPTIONS NEWDEFN=(YES,ECHO),USERGEN=CXRNRF
*****
APPCU01  PCCU AUTOSYN=YES, *
          BACKUP=YES, *
          CDUMPDS=CSPDUMP, *
          DUMPDS=VTAMDUMP, *
          MAXDATA=21384, *
          MDUMPDS=MOSSDUMP, *
          NETID=NETA, *
          OWNER=A01N, *
          SUBAREA=01, *
          TGN=ANY
APPCU02  PCCU AUTOSYN=YES, *
          BACKUP=YES, *
          CDUMPDS=CSPDUMP, *
          DUMPDS=VTAMDUMP, *
          MAXDATA=21384, *
          MDUMPDS=MOSSDUMP, *
          NETID=NETA, *
          OWNER=A02N, *
          SUBAREA=02, *
          TGN=ANY
*****
IFWA04   BUILD ADDESS=400, *
          AUXADDR=500, *
          BACKUP=50, *
          BFRS=128, *
          BRANCH=8000, *
          CATRACE=(YES,255), *
          CSSTIER=B, *
          CWALL=26, *
          DYNNSC=50, *
```

Figure A-3 (Part 2 of 43). NCP A04 Sample Generation Definition

## NCP A04 Sample Generation Definition

```

DYNNSX=50, *
DYNPOOL=(50,35), *
ENABLT0=30.0, *
ERLIMIT=16, *
HPR=YES, *
HPRATT=125000, *
HPRMLC=9, *
HPRMPS=0, *
HPRQLIM=0, *
LOADLIB=NCPLoad, *
LTRACE=8, *
MAXSSCP=8, *
MLTGORDR=MLTGPRI, *
MODEL=3745-210, *
NAMTAB=120, *
NCPTRACE=ON, *
NETID=NETA, *
NEWNAME=IFWA04, *
NUMHSAS=8, *
NPA=(YES,DR), *
OLT=NO, *
PWROFF=YES, *
SALIMIT=511, *
SESSACC=(YES,ALL,,10000,1000,,100,200,500,600,750,900), *
SLOWDOWN=12, *
SUBAREA=04, *
TRACE=(YES,100), *
TRANSFR=200, *
TYPGEN=NCP, *
TYP SYS=MVS, *
T2TIMER=(1.9,2.0,3), *
USGTIER=5, *
VERSION=V7R5F, *
VRPOOL=254, *
VRTIMER0=(180,,50), *
VRTIMER1=(180,,50), *
VRTIMER2=(180,,50), *
T1TIMER=(19.0,20.0)
*****
* DYNAMIC CONTROL FACILITIES USED BY VTAM *
*****
SYSCNTRL OPTIONS=(BACKUP,BHSASSC,ENDCALL,LNSTAT,MODE,NAKLIM,RC*
NTRL,RCOND,RECMD,RIMM,SESINIT,SESSION,SSPAUSE,STORDSP,XM*
TLMT)

```

Figure A-3 (Part 3 of 43). NCP A04 Sample Generation Definition

## NCP A04 Sample Generation Definition

```
*****
*      NCP HOST MACRO - CHANNEL ATTACHED HOST DEFINITIONS      *
*****
HOSTA01  HOST BFRPAD=0,                                         *
          MAXBFRU=100,                                         *
          SUBAREA=01,                                          *
          UNITSZ=256
HOSTA02  HOST BFRPAD=0,                                         *
          MAXBFRU=100,                                         *
          SUBAREA=02,                                          *
          UNITSZ=256
*****
*      PATH DEFINITIONS                                         *
*****
      PATH DESTSA=1,                                           *
          ER0=(1,1,5000,5000,5000,20000),                      *
          ER1=(1,1),                                           *
          ER2=(1,1),                                           *
          ER3=(1,1),                                           *
          ER4=(1,1),                                           *
          ER5=(1,1),                                           *
          ER6=(1,1),                                           *
          ER7=(1,1),                                           *
          VR0=0,                                               *
          VRPWS00=(1,3),                                       *
          VRPWS01=(1,3),                                       *
          VRPWS02=(1,3),                                       *
          VR1=1,                                               *
          VRPWS10=(2,6),                                       *
          VRPWS11=(2,6),                                       *
          VRPWS12=(2,6),                                       *
          VR2=2,                                               *
          VRPWS20=(3,9),                                       *
          VRPWS21=(3,9),                                       *
          VRPWS22=(3,9),                                       *
          VR3=3,                                               *
          VRPWS30=(3,9),                                       *
          VRPWS31=(3,9),                                       *
          VRPWS32=(3,9),                                       *
          VR4=4,                                               *
          VRPWS40=(3,9),                                       *
          VRPWS41=(3,9),                                       *
          VRPWS42=(3,9),                                       *
          VR5=5,                                               *
          VRPWS50=(3,9),                                       *
```

Figure A-3 (Part 4 of 43). NCP A04 Sample Generation Definition

## NCP A04 Sample Generation Definition

```

VRPWS51=(3,9), *
VRPWS52=(3,9), *
VR6=6, *
VRPWS60=(3,9), *
VRPWS61=(3,9), *
VRPWS62=(3,9), *
VR7=7, *
VRPWS70=(3,9), *
VRPWS71=(3,9), *
VRPWS72=(3,9) *
PATH DESTSA=2, *
ER0=(2,1,5000,5000,5000,20000), *
ER1=(2,1), *
ER2=(2,1), *
ER3=(2,1), *
ER4=(2,1), *
ER5=(2,1), *
ER6=(2,1), *
ER7=(2,1), *
VR0=0, *
VRPWS00=(1,3), *
VRPWS01=(1,3), *
VRPWS02=(1,3), *
VR1=1, *
VRPWS10=(2,6), *
VRPWS11=(2,6), *
VRPWS12=(2,6), *
VR2=2, *
VRPWS20=(3,9), *
VRPWS21=(3,9), *
VRPWS22=(3,9), *
VR3=3, *
VRPWS30=(3,9), *
VRPWS31=(3,9), *
VRPWS32=(3,9), *
VR4=4, *
VRPWS40=(3,9), *
VRPWS41=(3,9), *
VRPWS42=(3,9), *
VR5=5, *
VRPWS50=(3,9), *
VRPWS51=(3,9), *
VRPWS52=(3,9), *
VR6=6, *
VRPWS60=(3,9), *
VRPWS61=(3,9), *
VRPWS62=(3,9), *
VR7=7, *
VRPWS70=(3,9), *

```

*Figure A-3 (Part 5 of 43). NCP A04 Sample Generation Definition*

## NCP A04 Sample Generation Definition

```

VRPWS71=(3,9), *
VRPWS72=(3,9)
PATH DESTSA=(3,17,500), *
ER0=(3,1), *
ER1=(3,1), *
ER2=(3,1), *
ER3=(3,1), *
ER4=(3,1), *
ER5=(3,1), *
ER6=(3,1), *
ER7=(3,1), *
VR0=0, *
VRPWS00=(1,3), *
VRPWS01=(1,3), *
VRPWS02=(1,3), *
VR1=1, *
VRPWS10=(2,6), *
VRPWS11=(2,6), *
VRPWS12=(2,6), *
VR2=2, *
VRPWS20=(3,9), *
VRPWS21=(3,9), *
VRPWS22=(3,9), *
VR3=3, *
VRPWS30=(3,9), *
VRPWS31=(3,9), *
VRPWS32=(3,9), *
VR4=4, *
VRPWS40=(3,9), *
VRPWS41=(3,9), *
VRPWS42=(3,9), *
VR5=5, *
VRPWS50=(3,9), *
VRPWS51=(3,9), *
VRPWS52=(3,9), *
VR6=6, *
VRPWS60=(3,9), *
VRPWS61=(3,9), *
VRPWS62=(3,9), *
VR7=7, *
VRPWS70=(3,9), *
VRPWS71=(3,9), *
VRPWS72=(3,9)
PATH DESTSA=(81,310), *
ER0=(310,1), *
ER1=(310,255), *
ER2=(310,1), *
ER3=(310,255), *
ER4=(310,1), *
ER5=(310,255), *

```

Figure A-3 (Part 6 of 43). NCP A04 Sample Generation Definition

## NCP A04 Sample Generation Definition

```

ER6=(310,1), *
ER7=(310,255), *
VR0=0, *
VRPWS00=(1,3), *
VRPWS01=(1,3), *
VRPWS02=(1,3), *
VR1=1, *
VRPWS10=(2,6), *
VRPWS11=(2,6), *
VRPWS12=(2,6), *
VR2=2, *
VRPWS20=(3,9), *
VRPWS21=(3,9), *
VRPWS22=(3,9), *
VR3=3, *
VRPWS30=(3,9), *
VRPWS31=(3,9), *
VRPWS32=(3,9), *
VR4=4, *
VRPWS40=(3,9), *
VRPWS41=(3,9), *
VRPWS42=(3,9), *
VR5=5, *
VRPWS50=(3,9), *
VRPWS51=(3,9), *
VRPWS52=(3,9), *
VR6=6, *
VRPWS60=(3,9), *
VRPWS61=(3,9), *
VRPWS62=(3,9), *
VR7=7, *
VRPWS70=(3,9), *
VRPWS71=(3,9), *
VRPWS72=(3,9)
*****
*   NCP SDLCST MACRO - SDLC SUBAREA COMMUNICATION CONTROLLER LINKS   *
*****
*
N04PRI   SDLCST MODE=PRI,GROUP=NTRINN
N04SEC   SDLCST MODE=SEC,GROUP=NTRSEC
*
S04PRI   SDLCST MODE=PRI,GROUP=A04GPRI
S04SEC   SDLCST MODE=SEC,GROUP=A04GSEC
*

```

Figure A-3 (Part 7 of 43). NCP A04 Sample Generation Definition

## NCP A04 Sample Generation Definition

```
*****
*   NCP POOL MACROS - DYNAMIC RECONFIGURATION & SWITCHED SDLC LINKS   *
*****
*
*       PUDRPOOL NUMBER=50
*       LUDRPOOL NUMILU=100,
*           NUMTYP1=02,
*           NUMTYP2=100
*
*****
*   NPA DEFINITION - NETWORK PERFORMANCE ANALYZER                       *
*****
*
A04NPAG  GROUP LNCTL=SDLC,
*           NPARSC=YES,
*           VIRTUAL=YES
*
A04NPAL  LINE
*
A04NPAP  PU
*
A04NPLU1 LU
A04NPLU2 LU
A04NPLU3 LU
A04NPLU4 LU
A04NPLU5 LU
A04NPLU6 LU
A04NPLU7 LU
A04NPLU8 LU
*
*****
*       VIRTUAL DEFINITIONS FOR NRF R7                                   *
*****
*
A04NRF1  GROUP DIAL=NO,
*           LNCTL=SDLC,
*           MODETAB=NRFLOG,
*           PACING=0,
*           VIROWNER=CXRNRF,
*           VIRTUAL=YES,
*           VPACING=0
*
N04LINE  LINE LINEFVT=CXRFVT,
*           PUFVT=CXRFVT,
*           LUFVT=(CXRFVT,CXRFVT),
*           LINECB=CXRXLNK
*

```

Figure A-3 (Part 8 of 43). NCP A04 Sample Generation Definition



## NCP A04 Sample Generation Definition

```

*****
*                               N04PU1 NRF SESSION PARTNER ROUTING                               *
*****
*
N04PU1  PU
*
N04LU1A LU  NRF.SESSPART=N04LU1D,NUMSESS=255,NRF.LUCAP=PRIMARY
N04LU1B LU  NRF.SESSPART=N04LU1F
N04LU1C LU  NRF.SESSPART=N04LU1G
N04LU1D LU  NRF.SESSPART=N04LU1A,NUMSESS=255
N04LU1F LU  NRF.SESSPART=N04LU1B
N04LU1G LU  NRF.SESSPART=N04LU1C
*
*****
*                               N04PU2 NRF TABLE, CORRELATION AND ARGUMENT ROUTING                               *
*****
*
N04PU2  PU
*
N04LU2A LU  NRF.ROUTE=FBTAB
N04LU2B LU  NRF.ROUTE=FBCTAB
N04LU2C LU  NRF.ROUTE=FBCTAB
N04LU2D LU  NRF.ROUTE=ARG1TB,NRF.LOCATE=LOCAT1
N04LU2F LU  NRF.CORRLTE=60,NRF.LOCATE=LOCAT2
N04LU2G LU  NRF.CORRLTE=60,NRF.LOCATE=LOCAT2
N04LU2H LU  NRF.CORRLTE=0,NRF.LOCATE=LOCAT2
N04LU2I LU  NRF.CORRLTE=0
*
*****
*                               N04PU3 NRF TABLE AND ARGUMENT ROUTING                               *
*****
*
N04PU3  PU
*
N04LU3A LU  NRF.ROUTE=FXTAB1
N04LU3B LU  NRF.ROUTE=FXTAB2,NRF.DEFAULT=N04LU2B
N04LU3C LU  NRF.ROUTE=FXTAB3,NRF.DEFAULT=N04LU2B
N04LU3D LU  NRF.ROUTE=FXTAB4
N04LU3E LU  NRF.ROUTE=FXTAB0,NRF.LUCAP=PRIMARY
N04LU3F LU  NRF.ROUTE=FXTAB1,NRF.LUCAP=SECONDARY
N04LU3G LU  NRF.ROUTE=ARGTAB,NRF.LOCATE=LOCAT2
N04LU3H LU  NRF.ROUTE=ARGTAB,NRF.LOCATE=LOCAT2
N04LU3I LU  NRF.ROUTE=FXTABC
N04LU3J LU  NRF.ROUTE=FXTABN

```

Figure A-3 (Part 9 of 43). NCP A04 Sample Generation Definition

## NCP A04 Sample Generation Definition

```
*****
*           N04PU4 NRF CORRELATION ROUTING           *
*****
N04PU4  PU
*
N04LU4A LU  NRF.CORRLTE=60,NRF.DELAYT0=90,NRF.TAGLEN=2
*
FXTAB0  NRF.ROUTETAB
        NRF.ENTRY  ROUTDEST=N04LU3J
        NRF.TABEND
*
FXTABC  NRF.ROUTETAB
        NRF.ENTRY  ROUTDEST=N04LU3F
        NRF.TABEND
*
FXTABI  NRF.ROUTETAB
        NRF.ENTRY  ROUTDEST=N04LU3I
        NRF.TABEND
*
FXTAB1  NRF.ROUTETAB
        NRF.ENTRY  ROUTDEST=N04LU2F
        NRF.TABEND
*
FXTAB2  NRF.ROUTETAB
        NRF.ENTRY  ROUTDEST=N04LU2G
        NRF.TABEND
*
FXTAB3  NRF.ROUTETAB
        NRF.ENTRY  ROUTDEST=N04LU2H
        NRF.TABEND
*
FXTAB4  NRF.ROUTETAB
        NRF.ENTRY  ROUTDEST=N04LU4A
        NRF.TABEND
*
FBCTAB  NRF.ROUTETAB
        NRF.ENTRY  ROUTDEST=(N04LU2F,N04LU2G,N04LU2H,N04LU2I,N04LU4A)
        NRF.TABEND
*
FXTABN  NRF.ROUTETAB
        NRF.ENTRY  ROUTDEST=N04LU3E
        NRF.TABEND
*
ARGTAB  NRF.ROUTETAB
        NRF.ENTRY  ROUTEARG='C6C1'X,ROUTDEST=N04LU3I
        NRF.ENTRY  ROUTEARG='C6C2'X,ROUTDEST=N04LU3J
        NRF.ENTRY  ROUTEARG='C6C3'X,ROUTDEST=N04LU2A
        NRF.ENTRY  ROUTEARG='C6C4'X,ROUTDEST=N04LU2B
        NRF.TABEND
```

Figure A-3 (Part 10 of 43). NCP A04 Sample Generation Definition

## NCP A04 Sample Generation Definition

```

*
FBTAB  NRF.ROUTETAB
      NRF.ENTRY ROUTDEST=(N04LU3E,N04LU3F,N04LU3G,N04LU3B,N04LU3C)
      NRF.TABEND
*
ARG1TB NRF.ROUTETAB
      NRF.ENTRY ROUTEARG='C6'X,
      ROUTDEST=(N04LU3E,N04LU3G,N04LU3H,N04LU2C,N04LU2G)
      NRF.ENTRY ROUTEARG='C7'X,
      ROUTDEST=(N04LU3F,N04LU3H,N04LU2C,N04LU2G)
      NRF.ENTRY ROUTEARG='C8'X,
      ROUTDEST=(N04LU3E,N04LU3G,N04LU2A,N04LU2H)
      NRF.ENTRY ROUTEARG='C9'X,
      ROUTDEST=(N04LU3I,N04LU3G,N04LU3J,N04LU2B)
      NRF.TABEND
*
LOCAT1 NRF.LOCATE  FORMAT=(2,1)
LOCAT2 NRF.LOCATE  FORMAT=(2,2)
*
*****
* MULTIDROP SUBAREA LINKS TO A03NCP - PRIMARY SIDE
* - CONNECT LINE 000 OR LINE 032 TO A03NCP LINES 003 AND 004 USING
* MULTIPOINT MODEMS
* ** NOTE - BOTH THIS LINE & A04S128 OR A04S136 CANNOT BE ACTIVE AT
* THE SAME TIME
*****
*
A04GMUL1 GROUP LNCTL=SDLC,
           MODE=PRI
*
A04S00  LINE ADDRESS=(000,FULL),
           CLOCKNG=EXT,
           MONLINK=CONT,
           NRZI=YES,
           LPDATS=LPDA2,
           PAUSE=0.2,
           RETRIES=(,3,5),
           SPEED=2400,
           TRANSFR=20
*
           SERVICE ORDER=(A04P00A,A04P00B)
*

```

Figure A-3 (Part 11 of 43). NCP A04 Sample Generation Definition

## NCP A04 Sample Generation Definition

```
A04P00A  PU ADDR=02, *
          ANS=CONT, *
          IRETRY=YES, *
          NPACOLL=YES, *
          PUTYPE=4, *
          TGN=1
*
A04P00B  PU ADDR=03, *
          ANS=CONT, *
          IRETRY=YES, *
          LPDA=BLOCK, *
          NPACOLL=YES, *
          PUTYPE=4, *
          TGN=1
*
A04S32   LINE ADDRESS=(032,FULL), *
          CLOCKNG=EXT, *
          MONLINK=CONT, *
          NRZI=YES, *
          LPDATS=LPDA2, *
          PAUSE=0.2, *
          RETRIES=(,3,5), *
          SPEED=2400, *
          TRANSFR=20
*
          SERVICE ORDER=(A04P32A,A04P32B)
*
A04P32A  PU ADDR=02, *
          ANS=CONT, *
          IRETRY=YES, *
          NPACOLL=YES, *
          PUTYPE=4, *
          TGN=1
*
A04P32B  PU ADDR=03, *
          ANS=CONT, *
          IRETRY=YES, *
          LPDA=BLOCK, *
          NPACOLL=YES, *
          PUTYPE=4, *
          TGN=1
```

Figure A-3 (Part 12 of 43). NCP A04 Sample Generation Definition

## NCP A04 Sample Generation Definition

```

*
*****
* SUBAREA LINK: SDLC FOR PRIMARY/SECONDARY STATION *
*****
*
A04GPRI GROUP ACTIVTO=60.0, *
          DIAL=NO, *
          LNCTL=SDLC, *
          MODE=PRI, *
          REPLYTO=30, *
          TYPE=NCP
*
A04GSEC GROUP ACTIVTO=60.0, *
          DIAL=NO, *
          LNCTL=SDLC, *
          MODE=SEC, *
          TYPE=NCP
*
*****
* SDLC SUBAREA LINE - 9.6 KBPS LINK - TGN=1 - LPDATS=LPDA2 TESTING *
* CONNECT TO A31NCP LINE 001 OR LINE 33 *
*****
*
A04GINN1 GROUP ANS=CONT, *
              CLOCKNG=EXT, *
              DIAL=NO, *
              DUPLEX=FULL, *
              LPDATS=LPDA2, *
              LNCTL=SDLC, *
              MONLINK=NO, *
              NRZI=YES, *
              REPLYTO=3, *
              RETRIES=(30,1,3), *
              SDLCST=(S04PRI,S04SEC), *
              TGCONF=MULTI, *
              TGN=1
*
*****
* SUBAREA LINE ADDRESS=001 FULL DUPLEX *
*****
*
A04S01 LINE ADDRESS=(001,FULL), *
        MLTGPRI=10
*
A04P01 PU LPDA=ALLOW, *
        MAXDATA=6000, *
        PUTYPE=4
*

```

Figure A-3 (Part 13 of 43). NCP A04 Sample Generation Definition

## NCP A04 Sample Generation Definition

```
*****
* SUBAREA LINE ADDRESS=033 FULL DUPLEX *
*****
*
A04S33 LINE ADDRESS=(033,FULL), *
        MLTGPRI=10 *
*
A04P33 PU LPDA=ALLOW, *
        MAXDATA=6000, *
        PUTYPE=4 *
*
*****
* SDLC SUBAREA LINES - 1.2 Kbps LINK - TGN=1 - V.25 BIS CONNECTION *
* CONNECT TO A31NCP LINE 002 OR 034 THROUGH V.25 BIS MODEMS *
* - FOR LINE 002 IN A31NCP USE SWITCHED MAJOR NODE A02SAD02 *
* - FOR LINE 034 IN A31NCP USE SWITCHED MAJOR NODE A02SAD34 *
*****
*
A04GINN2 GROUP ACTIVTO=300.0, *
        DIAL=YES, *
        LNCTL=SDLC, *
        PUTYPE=4, *
        SDLCST=(S04PRI,S04SEC), *
        TGCONF=MULTI, *
        TYPE=NCP, *
        V25BIS=(YES,DLS DLC) *
*
A04S02 LINE ADDRESS=002, *
        AUTO=YES, *
        BRKCON=CONNECTO, *
        CALL=INOUT, *
        CLOCKNG=EXT, *
        DUPLEX=FULL, *
        MLTGPRI=20, *
        SPEED=1200, *
        V25BIS=(YES,DLS DLC) *
*
A04PU02 PU PUTYPE=4
*
A04S34 LINE ADDRESS=034, *
        AUTO=YES, *
        BRKCON=CONNECTO, *
        CALL=INOUT, *
        CLOCKNG=EXT, *
        DUPLEX=FULL, *
        MLTGPRI=20, *
        SPEED=1200, *
        V25BIS=(YES,DLS DLC) *
```

Figure A-3 (Part 14 of 43). NCP A04 Sample Generation Definition

# NCP A04 Sample Generation Definition

```
*
A04PU34  PU PUTYPE=4
*
*****
* SDLC SUBAREA LINES - 9.6 KBPS LINK - TGN=1 - SWITCHED CONNECTION *
*   CONNECT TO A31NCP LINE 003 OR 035 THROUGH 9.6 K MODEMS *
*   - FOR LINE 003 IN A31NCP USE SWITCHED MAJOR NODE A02SAD03 *
*   - FOR LINE 035 IN A31NCP USE SWITCHED MAJOR NODE A02SAD35 *
*****
*
A04GINN3 GROUP ACTIVTO=300.0, *
          DIAL=YES, *
          LNCTL=SDLC, *
          PUTYPE=4, *
          SDLCST=(S04PRI,S04SEC), *
          TGCONF=MULTI, *
          TYPE=NCP
*
A04S03  LINE ADDRESS=003, *
          AUTO=010, *
          BRKCON=CONNECTO, *
          CALL=INOUT, *
          CLOCKNG=EXT, *
          DUPLEX=HALF, *
          MLTGPRI=30, *
          SPEED=9600
*
A04PU03  PU PUTYPE=4
*
A04S35  LINE ADDRESS=035, *
          AUTO=042, *
          BRKCON=CONNECTO, *
          CALL=INOUT, *
          CLOCKNG=EXT, *
          DUPLEX=HALF, *
          MLTGPRI=30, *
          SPEED=9600
*
A04PU35  PU PUTYPE=4
*
*****
* SDLC SUBAREA LINKS *
*****
*
```

Figure A-3 (Part 15 of 43). NCP A04 Sample Generation Definition

## NCP A04 Sample Generation Definition

```

A04GINN4 GROUP ANS=CONT,
                CLOCKNG=EXT,
                DIAL=NO,
                DUPLEX=FULL,
                LNCTL=SDLC,
                MONLINK=NO,
                NRZI=YES,
                REPLYTO=3,
                RETRIES=(30,1,3),
                SDLCST=(S04PRI,S04SEC)
*
*****
* SDLC SUBAREA LINES - T1 LINKS - TGN=1 - CONNECTION TO A03NCP
*****
*
A04S128 LINE ADDRESS=(1028,FULL),
        SPEED=1544000,
        TGCONF=SINGLE,
        TGN=1
*
A04P128 PU MAXDATA=6000,
        PUTYPE=4
*
A04S136 LINE ADDRESS=(1036,FULL),
        SPEED=1544000,
        TGCONF=SINGLE,
        TGN=1
*
A04P136 PU MAXDATA=6000,
        PUTYPE=4
*
*****
* SDLC SUBAREA LINES - 56 KBPS - TGN=1 - CONNECTION FOR MIGRATION
*
*          CONNECT TO A31NCP LINE 020 OR 052
*
*****
*
A04S20  LINE ADDRESS=(020,FULL),
        MLTGPRI=40,
        TGCONF=MULTI,
        TGN=1
*
A04P20  PU MAXDATA=6000,
        PUTYPE=4
*

```

Figure A-3 (Part 16 of 43). NCP A04 Sample Generation Definition



## NCP A04 Sample Generation Definition

```

A04S52  LINE ADDRESS=(052,FULL),
        MLTGPRI=40,
        TGCONF=MULTI,
        TGN=1
*
A04P52  PU MAXDATA=6000,
        PUTYPE=4
*
*****
* SDLC RVX SUBAREA LINE - 9.6 KBPS LINK - TGN=1
*          CONNECT TO A31NCP LINE 2370
*
*****
A04GINN5 GROUP ANS=CONT,
               CLOCKNG=EXT,
               DIAL=NO,
               DUPLEX=FULL,
               LNCTL=SDLC,
               MONLINK=NO,
               NRZI=YES,
               REPLYTO=3,
               RETRIES=(30,1,3),
               SDLCST=(S04PRI,S04SEC),
               SPEED=9600,
               TGCONF=MULTI,
               TGN=1
*
*****
* SUBAREA LINE ADDRESS=2371 FULL DUPLEX
*
*****
A04S2371 LINE ADDRESS=(2371,FULL),
        MLTGPRI=10
*
A04P2371 PU MAXDATA=6000,
        PUTYPE=4
*
*****
* SDLC SUBAREA RVX LINE - 1.2 KBPS - TGN=1 - V.25 BIS CONNECTION
*          CONNECT TO A31NCP LINE 2379 THROUGH V.25 BIS MODEMS
*          USE SWITCHED MAJOR NODE A02SAD79
*
*****

```

Figure A-3 (Part 17 of 43). NCP A04 Sample Generation Definition

## NCP A04 Sample Generation Definition

```

A04GINN6 GROUP ACTIVTO=300.0, *
        DIAL=YES, *
        LNCTL=SDLC, *
        PUTYPE=4, *
        SDLCST=(S04PRI,S04SEC), *
        TGCONF=MULTI, *
        TYPE=NCP, *
        V25BIS=(YES,DLS DLC)
*
A04S2380 LINE ADDRESS=2380, *
        AUTO=YES, *
        BRKCON=CONNECTO, *
        CALL=INOUT, *
        CLOCKNG=EXT, *
        DUPLEX=FULL, *
        MLTGPRI=20, *
        SPEED=1200, *
        V25BIS=(YES,DLS DLC)
*
A04P2380 PU PUTYPE=4
*
*****
* SDLC RVX SUBAREA LINE - 9.6 Kbps SWITCHED LINK - TGN=1 *
* CONNECT TO A31NCP LINE 2372 THROUGH SWITCHED MODEMS *
*****
*
A04GINN7 GROUP ANS=CONT, *
        CLOCKNG=EXT, *
        DIAL=NO, *
        DUPLEX=HALF, *
        LNCTL=SDLC, *
        MONLINK=NO, *
        NRZI=YES, *
        REPLYTO=3, *
        RETRIES=(30,1,3), *
        SDLCST=(S04PRI,S04SEC), *
        SPEED=9600, *
        TGCONF=MULTI, *
        TGN=1
*
*****
* SUBAREA LINE ADDRESS=2373 HALF DUPLEX *
*****
*
A04S2373 LINE ADDRESS=2373, *
        MLTGPRI=10
*
A04P2373 PU MAXDATA=6000, *
        PUTYPE=4

```

Figure A-3 (Part 18 of 43). NCP A04 Sample Generation Definition

## NCP A04 Sample Generation Definition

```

*
*****
* FRAME RELAY PHYSICAL GROUP FOR ODLC FRAME RELAY LINE 2464      *
*****
A040FRP1 GROUP FRELAY=PHYSICAL,                                  *
        TYPE=NCP,                                              *
        DIAL=NO,                                               *
        LNCTL=SDLC,                                           *
        NPACOLL=(YES,EXTENDED),                               *
        PUTYPE=1
*
A04S2464 LINE ADDRESS=(2464,FULL),                              *
        CLOCKNG=EXT,                                          *
        DATABLK=2048,                                         *
        PORTADD=64,                                           *
        SPEED=56000
A04P2464 PU ANS=CONTINUE,                                       *
        INNPORT=YES,                                         *
        LMI=ANSI,                                           *
        PUDR=NO,                                             *
        NPACOLL=(YES,EXTENDED)
*****
* FRAME RELAY SUBAREA LOGICALS FOR 2464 TO A31NCP LINE 2468    *
*****
A040FRL1 GROUP FRELAY=(LOGICAL,SUBAREA),                       *
        PHYSRSC=A04P2464,                                    *
        SDLCST=(S04PRI,S04SEC),                              *
        TYPE=NCP,                                            *
        DIAL=NO,                                             *
        LNCTL=SDLC,                                           *
        NPACOLL=(YES,EXTENDED),                               *
        PUTYPE=4,                                             *
        RETRIES=(6,0,0)
*
A04LL64A LINE COMRATE=(NONE,2)
A04PL64A PU PUTYPE=4,                                          *
        TGN=1,                                              *
        DLCI=(17,D),                                         *
        NPACOLL=NO
*
A04LL64B LINE COMRATE=(NONE,8)
A04PL64B PU PUTYPE=4,                                          *
        TGN=1,                                              *
        DLCI=(18,D),                                         *
        NPACOLL=NO

```

Figure A-3 (Part 19 of 43). NCP A04 Sample Generation Definition

## NCP A04 Sample Generation Definition

```
*
*****
* ISDN PHYSICAL LINES *
*****
A04IPHY1 GROUP ISDN=PHYSICAL, *
                ISTATUS=ACTIVE, *
                DIAL=NO, *
                LNCTL=SDLC, *
                SPEED=2048000, *
                PUTYPE=1, *
                PUDR=NO
*
*****
* ISDN PHYSICAL LINE 2688 *
*****
A04I2688 LINE ADDRESS=(2688,FULL), *
                CLOCKNG=EXT, *
                ISDNLPN=8032373936, *
                LMI=ANSI, *
                ISDNCFG=NOCRC, *
                PORTADD=96, *
                NRZI=NO, *
                SPEED=2048000
A04P2688 PU ANS=CONTINUE, *
                ADDR=01, *
                INNPORT=YES
*
*****
* ISDN B CHANNEL DEFINITIONS FOR LINE 2688 *
*****
A04ICHN1 GROUP ISDN=(LOGICAL,B), *
                PHYSRSC=A04P2688, *
                DIAL=YES, *
                LNCTL=SDLC, *
                SPEED=64000, *
                PUTYPE=1
*
A04I2689 LINE ADDRESS=(2689,FULL), *
                CALL=IN, *
                ID=07002689
```

Figure A-3 (Part 20 of 43). NCP A04 Sample Generation Definition

## NCP A04 Sample Generation Definition

```
A04P2689 PU ANS=CONTINUE, *
        INNPORT=YES
*
A04I2690 LINE ADDRESS=(2690,FULL), *
        CALL=IN, *
        ID=07002690
A04P2690 PU ANS=CONTINUE, *
        INNPORT=YES
*
*****
* ISDN BNN LOGICAL LINES
*****
A04ISBG1 GROUP ISDN=(LOGICAL,PER), *
        PHYSRSC=NONE, *
        PUTYPE=2, *
        T2TIMER=(0.2,,3), *
        CALL=INOUT, *
        DIAL=YES, *
        LNCTL=SDLC, *
        LINEAUT=YES, *
        RETRIES=(6,0,0)
*
A04IBL01 LINE ADDRESS=NONE
A04IBP01 PU PUTYPE=2
*
*****
* ISDN INN LOGICAL LINES
*****
A04ISIG1 GROUP ISDN=(LOGICAL,SUB), *
        PHYSRSC=NONE, *
        PUTYPE=4, *
        SDLCST=(S04PRI,S04SEC), *
        CALL=INOUT, *
        DIAL=YES, *
        LNCTL=SDLC, *
        LINEAUT=YES, *
        RETRIES=(6,0,0)
*
A04IIL01 LINE ADDRESS=NONE
A04IIP01 PU PUTYPE=4
*
```

Figure A-3 (Part 21 of 43). NCP A04 Sample Generation Definition

## NCP A04 Sample Generation Definition

```
*****
* SDLC SUBAREA RVX LINES - TGN=1 CONNECTION *
*****
*
A04GINN8 GROUP ANS=CONT, *
                CLOCKNG=EXT, *
                DIAL=NO, *
                DUPLEX=FULL, *
                LNCTL=SDLC, *
                MONLINK=NO, *
                NRZI=YES, *
                REPLYTO=3, *
                RETRIES=(30,1,3), *
                SDLCST=(S04PRI,S04SEC), *
                TGCONF=MULTI, *
                TGN=1
*
*****
* SDLC RVX SUBAREA LINE ADDRESS=2436 - 56KB LINK TO A31NCP LINE 2432 *
*****
A04S2436 LINE ADDRESS=(2436,FULL), *
                ADDIFG=YES, *
                MLTGPRI=40, *
                SPEED=56000, *
                TGN=1
*
A04P2436 PU MAXDATA=6000, *
                PUTYPE=4
*
*****
* SDLC RVX SUBAREA LINE ADDRESS=2528 - T1 LINK TO A31NCP LINE 2496 *
*****
*
A04S2528 LINE ADDRESS=(2528,FULL), *
                CLOCKNG=DIRECT, *
                SPEED=1536000, *
                TGN=1
*
A04P2528 PU MAXDATA=6000, *
                PUTYPE=4
*
```

Figure A-3 (Part 22 of 43). NCP A04 Sample Generation Definition

## NCP A04 Sample Generation Definition

```
*****
*          CASUAL CONNECTION OVER SWITCHED LINE          *
* CONNECT TO A31NCP LINE 004 OR LINE 036 THROUGH SWITCHED MODEMS *
*   - FOR LINE 004 IN A31NCP USE SWITCHED MAJOR NODE A02CCN04 *
*   - FOR LINE 036 IN A31NCP USE SWITCHED MAJOR NODE A02CCN36 *
*****
*
A04CCNG1 GROUP CALL=INOUT, *
                DIAL=YES, *
                LNCTL=SDLC, *
                REPLYTO=3, *
                TYPE=NCP, *
                XMITDLY=23.5
*
A04CCN04 LINE ADDRESS=(004,HALF), *
            AUTO=011, *
            CALL=INOUT, *
            CLOCKNG=EXT, *
            DUPLEX=HALF, *
            PAUSE=1.0, *
            ROLE=NEG
*
A04PC04 PU AVGPB=140, *
        PUTYPE=2, *
        XID=YES
*
A04CCN36 LINE ADDRESS=(036,HALF), *
            AUTO=043, *
            CALL=INOUT, *
            CLOCKNG=EXT, *
            DUPLEX=HALF, *
            PAUSE=1.0, *
            ROLE=NEG
*
A04PC36 PU AVGPB=140, *
        PUTYPE=2, *
        XID=YES
*
*****
* LEASED 56 KBPS PERIPHERAL - CASUAL CONNECTION TO A31NCP *
*   CONNECTS TO LINE 016 OR 048 *
*****
*
A04CCNG2 GROUP DIAL=NO, *
                LNCTL=SDLC, *
                MODE=SEC, *
                TYPE=NCP
*

```

Figure A-3 (Part 23 of 43). NCP A04 Sample Generation Definition

## NCP A04 Sample Generation Definition

```
A04CCN16 LINE ADDRESS=(016,FULL), *
          CLOCKNG=EXT, *
          DUPLEX=HALF, *
          MAXPU=1, *
          NRZI=NO, *
          PAUSE=1.0, *
          RETRIES=(5), *
          SPEED=56000, *
          TADDR=C1
*
          SERVICE ORDER=(A04PC16),MAXLIST=1
*
A04PC16 PU MAXDATA=6000, *
          MODULO=128, *
          PASSLIM=12, *
          PUTYPE=2, *
          XID=YES
*
APPL81B LU LOCADDR=0, *
          PACING=(1)
APPL81C LU LOCADDR=0, *
          PACING=(1)
*
A04CCN48 LINE ADDRESS=(048,FULL), *
          CLOCKNG=EXT, *
          DUPLEX=HALF, *
          MAXPU=1, *
          NRZI=NO, *
          PAUSE=1.0, *
          RETRIES=(5), *
          SPEED=56000, *
          TADDR=C1
*
          SERVICE ORDER=(A04PC481),MAXLIST=1
*
A04PC481 PU MAXDATA=6000, *
          MODULO=128, *
          PASSLIM=12, *
          PUTYPE=2, *
          XID=YES
*
APPL81B1 LU LOCADDR=0, *
          PACING=(1)
APPL81C1 LU LOCADDR=0, *
          PACING=(1)
```

Figure A-3 (Part 24 of 43). NCP A04 Sample Generation Definition



## NCP A04 Sample Generation Definition

```

*
*****
*          CASUAL CONNECT OVER SWITCHED RVX LINE 2378          *
*          CONNECT TO A31NCP LINE 2377                        *
*          USE SWITCHED MAJOR NODE A02CCN77                    *
*****
*
A04CCNG3 GROUP CALL=INOUT,                                     *
                DIAL=YES,                                     *
                LNCTL=SDLC,                                  *
                REPLYTO=3,                                   *
                SPEED=4800,                                  *
                TYPE=NCP,                                    *
                XMITDLY=23.5                                  *
*
A04CCN78 LINE ADDRESS=(2378,HALF),                             *
                CALL=INOUT,                                  *
                CLOCKNG=EXT,                                 *
                DUPLEX=HALF,                                 *
                PAUSE=1.0,                                   *
                ROLE=NEG                                      *
*
A04PC781 PU AVGPB=140,                                         *
                PUTYPE=2,                                    *
                XID=YES                                       *
*
*****
*          LEASED RVX 56 Kbps PERIPHERAL LINE 2444            *
*          CASUAL CONNECTION TO A31NCP CONNECTS TO LINE 2440 *
*****
*
A04CCNG4 GROUP DIAL=NO,                                        *
                LNCTL=SDLC,                                  *
                MODE=SEC,                                    *
                TYPE=NCP                                      *
*
A04CCN44 LINE ADDRESS=(2444,FULL),                             *
                CLOCKNG=EXT,                                 *
                DUPLEX=HALF,                                 *
                MAXPU=1,                                     *
                NRZI=NO,                                     *
                PAUSE=1.0,                                   *
                RETRIES=(5),                                 *
                SPEED=56000,                                 *
                TADDR=C1                                     *

```

Figure A-3 (Part 25 of 43). NCP A04 Sample Generation Definition

## NCP A04 Sample Generation Definition

```
*
      SERVICE ORDER=(A04PC441),MAXLIST=1
*
A04PC441 PU MAXDATA=6000,
          MODULO=128,
          PASSLIM=12,
          PUTYPE=2,
          XID=YES
*
APPL81D LU LOCADDR=0,
          PACING=(1)
APPL81E LU LOCADDR=0,
          PACING=(1)
*
*****
*   NCP/TOKEN RING INTERCONNECT PHYSICAL LINES
*****
*
A04NTR1 GROUP ADAPTER=TIC2,
              ANS=CONTINUE,
              ECLTYPE=(PHYSICAL,SUB),
              NPACOLL=(YES,EXTENDED),
              TRSPEED=16,
              USSTAB=AUSSTAB,
              XID=NO,
              TYPE=NCP,
              DIAL=NO,
              LNCTL=SDLC,
              LEVEL2=ECLNARL2,
              LEVEL3=ECLNARL3,
              LEVEL5=NCP,
              TIMER=(ECLNART1,,ECLNART2,ECLNART3),
              XIO=(ECLNARXL,ECLNARXS,ECLNARXI,ECLNARXK),
              USERID=(5668854,ECLRBDT,NORECMS,,ECLNMVT),
              SPEED=9600,
              PUTYPE=1,
              PUDR=NO,
              COMPTAD=YES,
              COMPSWP=YES,
              COMPOWN=YES
*
*****
*   ADDRESS 1088 - NTRI SUBAREA PHYSICAL CONNECTION
*****
*
```

Figure A-3 (Part 26 of 43). NCP A04 Sample Generation Definition

## NCP A04 Sample Generation Definition

```

A04TR88  LINE ADDRESS=(1088,FULL),          *
          LOCADD=400000000431,             *
          MAXTSL=16348,                    *
          PORTADD=1,                       *
          RCVBUFC=32000,                   *
          UACB=(X$P1AX,X$P1AR)
*
A04PU88  PU ADDR=01,                      *
          INNPORT=YES
*
*****
*   ADDRESS 1092 - NTRI SUBAREA PHYSICAL CONNECTION   *
*****
*
A04TR92  LINE ADDRESS=(1092,FULL),          *
          LOCADD=400000000435,             *
          MAXTSL=16348,                    *
          PORTADD=5,                       *
          RCVBUFC=32000,                   *
          UACB=(X$P2AX,X$P2AR)
*
A04PU92  PU ADDR=01,                      *
          INNPORT=YES
*
*****
*
A04NTR2  GROUP ADAPTER=TIC2,              *
          ANS=CONTINUE,                    *
          ECLTYPE=(PHYSICAL,PER),          *
          NPACOLL=(YES,EXTENDED),         *
          TRSPEED=4,                       *
          USSTAB=AUSSTAB,                  *
          XID=NO,                           *
          TYPE=NCP,                         *
          DIAL=NO,                          *
          LNCTL=SDLC,                       *
          LEVEL2=ECLNARL2,                  *
          LEVEL3=ECLNARL3,                  *
          LEVEL5=NCP,                       *
          TIMER=(ECLNART1,,ECLNART2,ECLNART3), *
          XIO=(ECLNARXL,ECLNARXS,ECLNARXI,ECLNARXK), *
          USERID=(5668854,ECLRBDT,NORECMS,,ECLNMVT), *

```

Figure A-3 (Part 27 of 43). NCP A04 Sample Generation Definition

## NCP A04 Sample Generation Definition

```

SPEED=9600, *
PUTYPE=1, *
PUDR=NO, *
COMPTAD=YES, *
COMPSWP=YES, *
COMPOWN=YES
*
*****
* NTRI PERIPHERAL PHYSICAL CONNECTIONS- SAME LOCADD AS NTRI IN A31NCP *
*****
*
A04TR89 LINE ADDRESS=(1089,FULL), *
LOCADD=400000000032, *
MAXTSL=4060, *
PORTADD=2, *
RCVBUFC=32000, *
UACB=(X$P3AX,X$P3AR)
*
A04PU89 PU ADDR=01
*
A04TR93 LINE ADDRESS=(1093,FULL), *
LOCADD=400000000036, *
MAXTSL=4060, *
PORTADD=6, *
RCVBUFC=32000, *
UACB=(X$P4AX,X$P4AR)
*
A04PU93 PU ADDR=01
*
*****
* NTRI PERIPHERAL LOGICAL LINES - GENERATED IN NEWDEFN *
*****
*
A04BNG1 GROUP ANS=CONTINUE, *
AUTOGEN=20, *
CALL=INOUT, *
ECLTYPE=LOGICAL, *
ISTATUS=ACTIVE, *
MODETAB=AMODETAB, *
NPACOLL=(YES,EXTENDED), *
PHYPORT=2, *
RETRIES=(10,10,10,10), *
SRT=(100,10,YES), *
USSTAB=AUSSTAB, *
XMITDLY=NONE, *
TYPE=NCP, *
DIAL=YES, *
LNCTL=SDLC, *
LEVEL2=ECLNAVL2, *
LEVEL3=ECLNAVL3, *
LEVEL5=NCP, *
XIO=(ECLNAVXL,ECLNAVXS,ECLNAVXI,ECLNAVXK), *
USERID=(5668854,ECLVBDT,NORECMS,,ECLNMVT), *
LINEADD=NONE, *
LINEAUT=YES, *
PUTYPE=2, *
COMPOWN=YES
*

```

Figure A-3 (Part 28 of 43). NCP A04 Sample Generation Definition

# NCP A04 Sample Generation Definition

```
*****
* NTRI PERIPHERAL LOGICAL LINES - GENERATED IN NEWDEFN *
*****
*
A04BNNG2 GROUP ANS=CONTINUE, *
                AUTOGEN=20, *
                CALL=INOUT, *
                ECLTYPE=LOGICAL, *
                ISTATUS=ACTIVE, *
                MODETAB=AMODETAB, *
                NPACOLL=(YES,EXTENDED), *
                PHYPORT=6, *
                RETRIES=(10,10,10,10), *
                SRT=(100,10,YES), *
                USSTAB=AUSSTAB, *
                XMITDLY=NONE, *
                TYPE=NCP, *
                DIAL=YES, *
                LNCTL=SDLC, *
                LEVEL2=ECLNAVL2, *
                LEVEL3=ECLNAVL3, *
                LEVEL5=NCP, *
                XI0=(ECLNAVXL,ECLNAVXS,ECLNAVXI,ECLNAVXK), *
                USERID=(5668854,ECLVBDT,NORECMS,,ECLNMVT), *
                LINEADD=NONE, *
                LINEAUT=YES, *
                PUTYPE=2, *
                COMPOWN=YES
*
***** SDLC GROUP FOR PRIMARY/SECONDARY STATION *****
*****
*
NTRINN  GROUP ACTIVTO=420, *
                DIAL=NO, *
                LNCTL=SDLC, *
                MODE=PRI, *
                REPLYTO=3
*
NTRSEC  GROUP ACTIVTO=420, *
                DIAL=NO, *
                LNCTL=SDLC, *
                MODE=SEC
*

```

Figure A-3 (Part 29 of 43). NCP A04 Sample Generation Definition

## NCP A04 Sample Generation Definition

```

*****
*      NTRI SUBAREA LOGICAL LINE - ASSOCIATED WITH A04TR88      *
*****
*
A04INNG1 GROUP ANS=CONTINUE,                                     *
                ECLTYPE=(LOGICAL,SUBAREA),                       *
                MAXOUT=3,                                         *
                MODETAB=AMODETAB,                                 *
                NPACOLL=(YES,EXTENDED),                          *
                PHYPORT=1,                                        *
                SDLCST=(N04PRI,N04SEC),                           *
                SRT=(100,10,YES),                                 *
                TGCONF=MULTI,                                     *
                USSTAB=AUSSTAB,                                   *
                TYPE=NCP,                                        *
                DIAL=NO,                                          *
                LNCTL=SDLC,                                       *
                LEVEL2=ECLNAVL2,                                  *
                LEVEL3=ECLNAVL3,                                  *
                LEVEL5=NCP,                                       *
                XIO=(ECLNAVXL,ECLNAVXS,ECLNAVXI,ECLNAVXK),      *
                USERID=(5668854,ECLVBDT,NORECMS,,ECLNMVT),     *
                LINEADD=NONE,                                     *
                PUTYPE=4,                                         *
                COMPOWN=YES,                                      *
                RETRIES=(6,0,0,6)
*
*****
* NTRI SUBAREA LOGICAL CONNECTION TO NCP A31NCP -- TGN=1      *
*****
*
A04LG1A  LINE MLTGPRI=50,                                       *
          TGN=1,                                                 *
          UACB=X$L41A
*
A04PG1A  PU ADDR=04400000003131,                                 *
          MAXDATA=6000
*
A04LG2A  LINE MLTGPRI=60,                                       *
          TGN=1,                                                 *
          UACB=X$L42A
*

```

Figure A-3 (Part 30 of 43). NCP A04 Sample Generation Definition

## NCP A04 Sample Generation Definition

```

A04PG2A  PU ADDR=0C40000009999,          *
          MAXDATA=6000
*
A04LG3A  LINE MLTGPRI=50,                *
          TGN=1,                          *
          UACB=X$L43A
*
A04PG3A  PU ADDR=0440000003135,          *
          MAXDATA=6000
*
*****
*      NTRI SUBAREA LOGICAL LINE - ASSOCIATED WITH A04TR92      *
*****
*
A04INNG2 GROUP ANS=CONTINUE,              *
               ECLTYPE=(LOGICAL,SUBAREA), *
               MAXOUT=3,                  *
               MODETAB=AMODETAB,          *
               NPACOLL=(YES,EXTENDED),    *
               PHYPORT=5,                 *
               SDLCST=(N04PRI,N04SEC),    *
               SRT=(100,10,YES),          *
               TGCONF=MULTI,              *
               USSTAB=AUSSTAB,            *
               TYPE=NCP,                   *
               DIAL=NO,                    *
               LNCTL=SDLC,                 *
               LEVEL2=ECLNAV2,             *
               LEVEL3=ECLNAV3,             *
               LEVEL5=NCP,                 *
               XI0=(ECLNAVXL,ECLNAVXS,ECLNAVXI,ECLNAVXK), *
               USERID=(5668854,ECLVBDT,NORECMS,,ECLNMVT), *
               LINEADD=NONE,               *
               PUTYPE=4,                   *
               COMPOWN=YES,                *
               RETRIES=(6,0,0,6)
*
*****
*      NTRI SUBAREA LOGICAL CONNECTION TO NCP A31NCP  --  TGN=1  *
*****
*
A04LG1B  LINE MLTGPRI=50,                *
          TGN=1,                          *
          UACB=X$L44A
*

```

Figure A-3 (Part 31 of 43). NCP A04 Sample Generation Definition

## NCP A04 Sample Generation Definition

```

A04PG1B  PU ADDR=0440000003131,          *
          MAXDATA=6000
*
A04LG2B  LINE MLTGPRI=60,                *
          TGN=1,                          *
          UACB=X$L45A
*
A04PG2B  PU ADDR=0C40000009999,          *
          MAXDATA=6000
*
A04LG3B  LINE MLTGPRI=50,                *
          TGN=1,                          *
          UACB=X$L46A
*
A04PG3B  PU ADDR=0440000003135,          *
          MAXDATA=6000
*
*****
*
*   37CS PHYSICAL CONNECTIONS           *
*
*****
*
A0437CS  GROUP ADAPTER=TIC3,             *
          ANS=CONT,                       *
          DIAL=NO,                        *
          ECLTYPE=(PHY,ANY),              *
          ISTATUS=ACTIVE,                 *
          LNCTL=SDLC,                     *
          LSPRI=NO,                       *
          PUDR=NO,                        *
          PUTYPE=1,                        *
          TYPE=NCP,                       *
          XID=NO,                         *
          SPEED=9600,                     *
          NPACOLL=NO
*
A04L2080 LINE ADAPTER=TIC3,              *
          ADDRESS=(2080,FULL),            *
          ANS=CONT,                       *
          BEACTO=52,                      *
          LOCADD=40000009021,             *
          LSPRI=NO,                       *
          MAXTSL=288,                     *
          PORTADD=7,                      *
          TRSPEED=16

```

Figure A-3 (Part 32 of 43). NCP A04 Sample Generation Definition



## NCP A04 Sample Generation Definition

```
*
A04P2080 PU ANS=CONT,
      INNPORT=YES,
      PUDR=NO,
      PUTYPE=1,
      XMONLNK=YES,
      ADDR=01
*
*****
*
* 37CS PERIPHERAL LOGICAL LINK DEFINITIONS TO A TOKEN=RING NODE
*
*****
*
A04BNNG3 GROUP ANS=CONT,
      AUTOGEN=5,
      CALL=INOUT,
      ECLTYPE=(LOG,PER),
      ISTATUS=ACTIVE,
      LINEAUT=YES,
      LNCTL=SDLC,
      PHYSRSC=A04P2080,
      PUTYPE=2,
      TYPE=NCP,
      DIAL=YES,
      NPACOLL=NO,
      RETRIES=(6,0,0,6)
*
*****
*
* ALLOWS SUBAREA TRAFFIC BETWEEN THE 2080 PHYSICAL LINE AND THE 1089
* OR 1093 NTRI LINES OF A31NCP
*
*****
*
A04INNG3 GROUP ANS=CONT,
      ECLTYPE=(LOG,SUB),
      ISTATUS=ACTIVE,
      LNCTL=SDLC,
      MONLINK=YES,
      PHYSRSC=A04P2080,
      PUTYPE=4,
      TGCONF=MULTI,
      TYPE=NCP,
      DIAL=NO,
      NPACOLL=NO,
      RETRIES=(6,0,0,6)
*
```

Figure A-3 (Part 33 of 43). NCP A04 Sample Generation Definition

## NCP A04 Sample Generation Definition

```

A04LG1C LINE MLTGPRI=70,
          SDLCST=(S04PRI,S04SEC),
          TGN=1,
          T2TIMER=(0.0,0.1,1)
*
A04PG1C PU ADDR=04400000000032,
          MAXDATA=6000
*
A04LG2C LINE MLTGPRI=70,
          SDLCST=(S04PRI,S04SEC),
          TGN=1,
          T2TIMER=(0.0,0.1,1)
*
A04PG2C PU ADDR=04400000000036,
          MAXDATA=6000
*
A04LG3C LINE MLTGPRI=70,
          SDLCST=(S04PRI,S04SEC),
          TGN=1,
          T2TIMER=(0.0,0.1,1)
*
A04PG3C PU ADDR=04400000007041,
          MAXDATA=6000
*
*****
*
*   PHYSICAL ESCON CHANNEL DEFINITIONS
*
*****
*
G04RSOC1 GROUP LNCTL=CA,
          SPEED=14400000,
          SRT=(32768,32768),
          XMONLNK=YES
*
A04S2240 LINE ADDRESS=2240          ESCON PHYSICAL CHANNEL ON LIM-5A
*
A04P2240 PU ANS=CONTINUE,
          PUTYPE=1
*
A04S2304 LINE ADDRESS=2304          ESCON PHYSICAL CHANNEL ON LIM-6A
*
A04P2304 PU ANS=CONTINUE,
          PUTYPE=1
*

```

Figure A-3 (Part 34 of 43). NCP A04 Sample Generation Definition

## NCP A04 Sample Generation Definition

```
*****
*
* LOGICAL ESCON CHANNEL DEFINITIONS
*
*****
*
*****
* ESCON LOGICAL RESOURCES ASSOCIATED WITH PHYSICAL LINE 1 (2240)
*
*****
*
G04LSOC1 GROUP CASDL=0.0,
                DELAY=0.2,
                LNCTL=CA,
                MAXPU=16,
                PHYRSC=A04P2240,
                PUDR=YES,
                SPEED=144000000,
                SRT=(20000,20000),
                TIMEOUT=840.0,
                TRANSFR=200
*
*****
*
* ESCON LOGICAL LINE 1, GROUP 1 (ESCON PHYSICAL CHANNEL 2240)
*
*****
*
A04S1L1 LINE ADDRESS=NONE,          ESCON PHYSICAL CHANNEL 2240
                HOSTLINK=1,          LOGICAL LINE 1
                MONLINK=CONT
*
A04S1P11 PU ADDR=01,
                ANS=CONTINUE,
                PUDR=NO,
                PUTYPE=5,
                TGN=1
*

```

Figure A-3 (Part 35 of 43). NCP A04 Sample Generation Definition

## NCP A04 Sample Generation Definition

```

A04S1P12 PU ADDR=02, *
                ANS=CONTINUE, *
                PUDR=NO, *
                PUTYPE=5, *
                TGN=1
*
A04S1P13 PU ADDR=03, *
                ANS=CONTINUE, *
                PUDR=NO, *
                PUTYPE=5, *
                TGN=1
*
A04S1P14 PU ADDR=04, *
                ANS=CONTINUE, *
                PUDR=NO, *
                PUTYPE=5, *
                TGN=1
*
*****
*
*   ESCON LOGICAL LINE 2, GROUP 1 (ESCON PHYSICAL CHANNEL 2240) *
*
*****
*
A04S1L2  LINE ADDRESS=NONE,          ESCON PHYSICAL CHANNEL 2240 *
                HOSTLINK=2,          LOGICAL LINE 2 *
                MONLINK=CONT
*
A04S1P21 PU ADDR=01, *
                ANS=CONTINUE, *
                PUDR=NO, *
                PUTYPE=5, *
                TGN=1
*

```

Figure A-3 (Part 36 of 43). NCP A04 Sample Generation Definition

## NCP A04 Sample Generation Definition

```

A04S1P22 PU ADDR=02, *
          ANS=CONTINUE, *
          PUDR=NO, *
          PUTYPE=5, *
          TGN=1
*
A04S1P23 PU ADDR=03, *
          ANS=CONTINUE, *
          PUDR=NO, *
          PUTYPE=5, *
          TGN=1
*
A04S1P24 PU ADDR=04, *
          ANS=CONTINUE, *
          PUDR=NO, *
          PUTYPE=5, *
          TGN=1
*
*****
*
*   ESCON LOGICAL LINE 3, GROUP 1 (ESCON PHYSICAL CHANNEL 2240) *
*
*****
*
A04S1L3  LINE ADDRESS=NONE,          ESCON PHYSICAL CHANNEL 2240 *
          HOSTLINK=3,                LOGICAL LINE 3 *
          MONLINK=NO
*
A04S1P31 PU ADDR=01, *
          ANS=CONTINUE, *
          PUDR=NO, *
          PUTYPE=5, *
          TGN=1
*
A04S1P32 PU ADDR=02, *
          ANS=CONTINUE, *
          PUDR=NO, *
          PUTYPE=5, *
          TGN=1
*
A04S1P33 PU ADDR=03, *
          ANS=CONTINUE, *
          PUDR=NO, *
          PUTYPE=5, *
          TGN=1
*

```

Figure A-3 (Part 37 of 43). NCP A04 Sample Generation Definition

## NCP A04 Sample Generation Definition

```
A04S1P34 PU ADDR=04, *
      ANS=CONTINUE, *
      PUDR=NO, *
      PUTYPE=5, *
      TGN=1
*
*****
*
*   ESCON LOGICAL LINE 4, GROUP 1 (ESCON PHYSICAL CHANNEL 2240) *
*
*****
*
A04S1L4 LINE ADDRESS=NONE,          ESCON PHYSICAL CHANNEL 2240 *
      HOSTLINK=4,          LOGICAL LINE 4 *
      MONLINK=NO
*
A04S1P41 PU ADDR=01, *
      ANS=CONTINUE, *
      PUDR=NO, *
      PUTYPE=5, *
      TGN=1
*
A04S1P42 PU ADDR=02, *
      ANS=CONTINUE, *
      PUDR=NO, *
      PUTYPE=5, *
      TGN=1
*
A04S1P43 PU ADDR=03, *
      ANS=CONTINUE, *
      PUDR=NO, *
      PUTYPE=5, *
      TGN=1
```

Figure A-3 (Part 38 of 43). NCP A04 Sample Generation Definition

## NCP A04 Sample Generation Definition

```
*
A04S1P44 PU ADDR=04, *
          ANS=CONTINUE, *
          PUDR=NO, *
          PUTYPE=5, *
          TGN=1
*
*****
*
*   ESCON LOGICAL RESOURCES ASSOCIATED WITH PHYSICAL LINE 2 (2304) *
*   *****
*
G04LSOC2 GROUP CASDL=0.0, *
              DELAY=0.2, *
              LNCTL=CA, *
              MAXPU=16, *
              PHYRSC=A04P2304, *
              PUDR=YES, *
              SPEED=144000000, *
              SRT=(20000,20000), *
              TIMEOUT=840.0, *
              TRANSFR=200
*
*****
*
*   ESCON LOGICAL LINE 1, GROUP 2 (ESCON PHYSICAL CHANNEL 2304) *
*   *****
*
A04S2L1 LINE ADDRESS=NONE,          ESCON PHYSICAL CHANNEL 2304 *
          HOSTLINK=1,                LOGICAL LINE 1 *
          MONLINK=CONT
*
A04S2P11 PU ADDR=01, *
          ANS=CONTINUE, *
          PUDR=NO, *
          PUTYPE=5, *
          TGN=1
*
A04S2P12 PU ADDR=02, *
          ANS=CONTINUE, *
          PUDR=NO, *
          PUTYPE=5, *
          TGN=1
*
```

Figure A-3 (Part 39 of 43). NCP A04 Sample Generation Definition

## NCP A04 Sample Generation Definition

```
A04S2P13 PU ADDR=03, *
          ANS=CONTINUE, *
          PUDR=NO, *
          PUTYPE=5, *
          TGN=1
*
A04S2P14 PU ADDR=04, *
          ANS=CONTINUE, *
          PUDR=NO, *
          PUTYPE=5, *
          TGN=1
*
*****
*
*   ESCON LOGICAL LINE 2, GROUP 2 (ESCON PHYSICAL CHANNEL 2304) *
*
*****
*
A04S2L2  LINE ADDRESS=NONE,          ESCON PHYSICAL CHANNEL 2304 *
          HOSTLINK=2,                LOGICAL LINE 2 *
          MONLINK=CONT
*
A04S2P21 PU ADDR=01, *
          ANS=CONTINUE, *
          PUDR=NO, *
          PUTYPE=5, *
          TGN=1
*
A04S2P22 PU ADDR=02, *
          ANS=CONTINUE, *
          PUDR=NO, *
          PUTYPE=5, *
          TGN=1
*
```

Figure A-3 (Part 40 of 43). NCP A04 Sample Generation Definition



## NCP A04 Sample Generation Definition

```

A04S2P23 PU ADDR=03,                                     *
              ANS=CONTINUE,                               *
              PUDR=NO,                                    *
              PUTYPE=5,                                    *
              TGN=1                                        *
*
A04S2P24 PU ADDR=04,                                     *
              ANS=CONTINUE,                               *
              PUDR=NO,                                    *
              PUTYPE=5,                                    *
              TGN=1                                        *
*
*****
*
*   ESCON LOGICAL LINE 3, GROUP 2 (ESCON PHYSICAL CHANNEL 2304)   *
*
*****
*
A04S2L3  LINE ADDRESS=NONE,          ESCON PHYSICAL CHANNEL 2304  *
              HOSTLINK=3,             LOGICAL LINE 3                *
              MONLINK=NO
*
A04S2P31 PU ADDR=01,                                     *
              ANS=CONTINUE,                               *
              PUDR=NO,                                    *
              PUTYPE=5,                                    *
              TGN=1                                        *
*
A04S2P32 PU ADDR=02,                                     *
              ANS=CONTINUE,                               *
              PUDR=NO,                                    *
              PUTYPE=5,                                    *
              TGN=1                                        *
*
A04S2P33 PU ADDR=03,                                     *
              ANS=CONTINUE,                               *
              PUDR=NO,                                    *
              PUTYPE=5,                                    *
              TGN=1                                        *
*
A04S2P34 PU ADDR=04,                                     *
              ANS=CONTINUE,                               *
              PUDR=NO,                                    *
              PUTYPE=5,                                    *
              TGN=1                                        *
*
*****
*
*   ESCON LOGICAL LINE 4, GROUP 2 (ESCON PHYSICAL CHANNEL 2304)   *
*
*****
*
A04S2L4  LINE ADDRESS=NONE,          ESCON PHYSICAL CHANNEL 2304  *
              HOSTLINK=4,             LOGICAL LINE 4                *
              MONLINK=NO
*
A04S2P41 PU ADDR=01,                                     *
              ANS=CONTINUE,                               *
              PUDR=NO,                                    *
              PUTYPE=5,                                    *
              TGN=1                                        *
*

```

Figure A-3 (Part 41 of 43). NCP A04 Sample Generation Definition

## NCP A04 Sample Generation Definition

```

A04S2P42 PU ADDR=02, *
                ANS=CONTINUE, *
                PUDR=NO, *
                PUTYPE=5, *
                TGN=1
*
A04S2P43 PU ADDR=03, *
                ANS=CONTINUE, *
                PUDR=NO, *
                PUTYPE=5, *
                TGN=1
*
A04S2P44 PU ADDR=04, *
                ANS=CONTINUE, *
                PUDR=NO, *
                PUTYPE=5, *
                TGN=1
*
*****
* CHANNEL ADAPTERS - CODED CA=TYPE7 WILL TAKE ADVANTAGE OF BUFFER *
* CHAINING CHANNEL ADAPTER IF INSTALLED. IT WILL *
* ACT AS TYPE 6 IF CADS IS INSTALLED. *
*****
*
A04CAG1 GROUP CA=TYPE7, *
                ISTATUS=ACTIVE, *
                LNCTL=CA, *
                NCPCA=ACTIVE, *
                NPACOLL=YES, *
                TIMEOUT=480.0, *
                TRANSFR=200
*
*****
* CA ADDR - 08 -- PHYSICAL PORT 1 -- TG=1 CONNECT TO HOST A01N *
*****
*
A04CP1 LINE ADDRESS=P1, *
                CASDL=420, *
                DELAY=0.2
*
A04P01A PU PUTYPE=5, *
                TGN=1
*

```

Figure A-3 (Part 42 of 43). NCP A04 Sample Generation Definition

## NCP A04 Sample Generation Definition

```
*****
* CA ADDR - 10 -- PHYSICAL PORT 3 -- TG=1 CONNECT TO HOST A02N *
*                               SHOULD BE BCCA CHANNEL IN 3745 *
*****
*
A04CP3  LINE ADDRESS=P3, *
        CASDL=420, *
        DELAY=0.2
*
A04P03A PU PUTYPE=5, *
        TGN=1
*
*****
* CA ADDR - 00 -- PHYSICAL PORT 5 -- TG=1 CONNECT TO HOST A01N *
*                               SHOULD BE BCCA CHANNEL IN 3745 *
*****
*
A04CP5  LINE ADDRESS=P5, *
        CASDL=420, *
        DELAY=0.2
*
A04P05A PU PUTYPE=5, *
        TGN=1
*
*****
* CA ADDR - 02 -- PHYSICAL PORT 7 -- TG=1 CONNECT TO HOST A02N *
*                               SHOULD BE BCCA CHANNEL IN 3745 *
*****
*
A04CP7  LINE ADDRESS=P7, *
        CASDL=420, *
        DELAY=0.2
*
A04P07A PU PUTYPE=5, *
        TGN=1
*
*
GENEND  GENEND
```

Figure A-3 (Part 43 of 43). NCP A04 Sample Generation Definition

## NCP A31 Sample Generation Definition

```

*****
*****
***** IFWA31 - NCP FOR SAMPLES NETWORK SUBAREA = 310 *****
*****
*
*          -----
*          |          HOST          |
*          |          A81          |
*          -----
*
*          | | | | |
* CA-3    | | | | |    CA-1
* TGN=255 | | | | |    TGN=1
*          | | | | |
*
*          -----
*          | NCP IFWA31          |
*          |          SA=310    |
*          -----
*
*****
*
* LINE          FUNCTION
* ----          -
* 000  FRAME RELAY BNN - FULL DUPLEX
* 001  LEASED SDLC 9.6KB FOR LPDA TESTING TO A04NCP LINE 001 OR 033
* 002  SWITCHED SDLC 1200BPS - V.25 BIS TO A04NCP LINE 002 OR 034
* 003  SWITCHED SDLC 9.6KB - SUBAREA TO A04NCP LINE 003 OR 035
* 004  SWITCHED CASUAL CONNECTION TO A04NCP LINE 004 OR 036
* 016  LEASED 56KB PERIPHERAL - CASUAL CONN - A04NCP LINE 016 OR 048
* 020  LEASED SDLC 56KB SUBAREA LINE- MIGRATION TO A04NCP 020 OR 052
* 032  FRAME RELAY BNN - FULL DUPLEX
* 033  LEASED SDLC 9.6KB FOR LPDA TESTING TO A04NCP LINE 001 OR 033
* 034  SWITCHED SDLC 1200BPS - V.25 BIS TO A04NCP LINE 002 OR 034
* 035  SWITCHED SDLC 9.6KB - SUBAREA TO A04NCP LINE 003 OR 035
* 036  SWITCHED CASUAL CONNECTION TO A04NCP LINE 004 OR 036
* 048  LEASED 56KB PERIPHERAL - CASUAL CONN - A04NCP LINE 016 OR 048
* 052  LEASED SDLC 56KB SUBAREA LINE- MIGRATION TO A04NCP 020 OR 052
* 1088  TOKEN-RING SUBAREA AND PERIPHERAL ( 4M )
* 1089  TOKEN-RING PERIPHERAL ONLY ( 16M )
* 1092  TOKEN-RING SUBAREA AND PERIPHERAL ( 4M ) - TO A04NCP
* 1093  TOKEN-RING PERIPHERAL ONLY ( 16M ) - TO A04NCP
* 2144  3746-900 LAN SUBAREA AND PERIPHERAL ( 16M )
* 2240  ESCON PHYSICAL LINE - LOGICAL LINES S1L1 - S1L2
* 2304  ESCON PHYSICAL LINE - LOGICAL LINES S2L1 - S2L2
* 2368  LEASED RVX SDLC LINE TO PU T1 - 3767
* 2369  LEASED RVX SDLC LINE TO PU T2 - 3276
* 2370  LEASED RVX SDLC 9.6KB SUBAREA LINE TO A04NCP LINE 2371
* 2372  SWITCHED MANUAL DIAL RVX SDLC 9.6KB TO A04NCP LINE 2373
* 2374  SWITCHED V.25 BIS 1200 BPS PU T2 - 3276
* 2377  SWITCHED RVX CASUAL CONNECTION TO A04NCP LINE 2378
* 2379  SWITCHED RVX SDLC 1200BPS - V.25 BIS TO A04NCP LINE 2380

```

Figure A-4 (Part 1 of 46). NCP A31 Sample Generation Definition

## NCP A31 Sample Generation Definition

```

* 2432 LEASED RVX SDLC 56KB SUBAREA LINE TO A04NCP LINE 2436
* 2440 LEASED RVX 56KB PERIPHERAL - CASUAL CONN - A04NCP LINE 2444
* 2468 FRAME RELAY SUBAREA LINE TO A04NCP 2464
* 2496 LEASED RVX SDLC T1 SUBAREA LINE TO A04NCP LINE 2528
* 2720 ISDN INTERFACE
* 2721 OR 2722 ISDN B CHANNELS USED FOR SUBAREA LINE TO
* A04NCP LINE 2689 OR 2690 AND PERIPHERAL CONNECTIONS
*
      OPTIONS NEWDEFN=(YES,ECHO),USERGEN=CXRNRF
*
*****
*
APCCU81  PCCU  AUTOSYN=YES,
          BACKUP=YES,
          CDUMPDS=CSPDUMP,
          DUMPDS=VTAMDUMP,
          MAXDATA=21384,
          MDUMPDS=MOSSDUMP,
          NETID=NETA,
          OWNER=A81N,
          SUBAREA=81,
          TGN=ANY
*
*****
*
IFWA31  BUILD  ADDESS=400,
             AUXADDR=500,
             BACKUP=50,
             BFRS=196,
             BRANCH=8000,
             CATRACE=(YES,255),
             CSSTIER=B,
             CWALL=26,
             DYNNSC=50,
             DYNNSX=50,
             DYNPOOL=(50,35),
             ENABLTO=30.0,
             ERLIMIT=16,
             HPR=YES,
             HPRATT=125000,
             HPRMLC=9,
             HPRMPS=0,
             HPRQLIM=0,
             LOADLIB=NCPLoad,
             LTRACE=8,
             MAXSSCP=8,
             MLTGORDR=MLTGPRi,

```

Figure A-4 (Part 2 of 46). NCP A31 Sample Generation Definition

## NCP A31 Sample Generation Definition

```

MODEL=3745-210, *
NAMTAB=120, *
NCPTRACE=ON, *
NETID=NETA, *
NEWNAME=IFWA31, *
NPA=(YES,DR), *
NUMHSAS=8, *
OLT=YES, *
PWROFF=YES, *
SALIMIT=511, *
SESSACC=(YES,ALL,,10000,1000,,100,200,500,600,750,900), *
SLOWDOWN=12, *
SUBAREA=310, *
TRACE=(YES,100), *
TRANSFR=200, *
TYPGEN=NCP, *
TYPSSYS=MVS, *
T2TIMER=(1.9,2.0,3), *
USGTIER=5, *
VERSION=V7R5F, *
VRPOOL=254, *
VRTIMER0=(180,,50), *
VRTIMER1=(180,,50), *
VRTIMER2=(180,,50), *
T1TIMER=(19.0,20.0)
*
*****
** DYNAMIC CONTROL FACILITIES USED BY VTAM *
*****
*
      SYSCNTRL OPTIONS=(BACKUP,BHSASSC,ENDCALL,LNSTAT,MODE,NAKLIM,RC*
        NTRL,RCOND,RECMD,RIMM,SESINIT,SESSION,SSPAUSE,STORDSP,XM*
        TLMT)
*
*****
** NCP HOST MACRO - CHANNEL ATTACHED HOST DEFINITIONS *
*****
*
HOSTA81 HOST BFRPAD=0, *
        MAXBFRU=100, *
        SUBAREA=81, *
        UNITSZ=256
*

```

Figure A-4 (Part 3 of 46). NCP A31 Sample Generation Definition

## NCP A31 Sample Generation Definition

```

*****
*   PATH DEFINITIONS   *
*****
*
*   PATH DESTSA=81,    *
*   ER0=(81,1),       *
*   ER1=(81,255),    *
*   ER2=(81,1),       *
*   ER3=(81,255),    *
*   ER4=(81,1),       *
*   ER5=(81,255),    *
*   ER6=(81,1),       *
*   ER7=(81,255),    *
*   VR0=0,            *
*   VRPWS00=(1,3),    *
*   VRPWS01=(1,3),    *
*   VRPWS02=(1,3),    *
*   VR1=1,            *
*   VRPWS10=(2,6),    *
*   VRPWS11=(2,6),    *
*   VRPWS12=(2,6),    *
*   VR2=2,            *
*   VRPWS20=(3,9),    *
*   VRPWS21=(3,9),    *
*   VRPWS22=(3,9),    *
*   VR3=3,            *
*   VRPWS30=(3,9),    *
*   VRPWS31=(3,9),    *
*   VRPWS32=(3,9),    *
*   VR4=4,            *
*   VRPWS40=(3,9),    *
*   VRPWS41=(3,9),    *
*   VRPWS42=(3,9),    *
*   VR5=5,            *
*   VRPWS50=(3,9),    *
*   VRPWS51=(3,9),    *
*   VRPWS52=(3,9),    *
*   VR6=6,            *
*   VRPWS60=(3,9),    *
*   VRPWS61=(3,9),    *
*   VRPWS62=(3,9),    *
*   VR7=7,            *
*   VRPWS70=(3,9),    *
*   VRPWS71=(3,9),    *
*   VRPWS72=(3,9)    *
*
*   PATH DESTSA=(1,2,3,4,17,500), *
*   ER0=(4,1),         *
*   ER1=(4,255),      *
*   ER2=(4,1),         *

```

Figure A-4 (Part 4 of 46). NCP A31 Sample Generation Definition

## NCP A31 Sample Generation Definition

```
ER3=(4,255), *
ER4=(4,1), *
ER5=(4,255), *
ER6=(4,1), *
ER7=(4,255), *
VR0=0, *
VRPWS00=(1,3), *
VRPWS01=(1,3), *
VRPWS02=(1,3), *
VR1=1, *
VRPWS10=(2,6), *
VRPWS11=(2,6), *
VRPWS12=(2,6), *
VR2=2, *
VRPWS20=(3,9), *
VRPWS21=(3,9), *
VRPWS22=(3,9), *
VR3=3, *
VRPWS30=(3,9), *
VRPWS31=(3,9), *
VRPWS32=(3,9), *
VR4=4, *
VRPWS40=(3,9), *
VRPWS41=(3,9), *
VRPWS42=(3,9), *
VR5=5, *
VRPWS50=(3,9), *
VRPWS51=(3,9), *
VRPWS52=(3,9), *
VR6=6, *
VRPWS60=(3,9), *
VRPWS61=(3,9), *
VRPWS62=(3,9), *
VR7=7, *
VRPWS70=(3,9), *
VRPWS71=(3,9), *
VRPWS72=(3,9) *
*
*****
*** NCP SDLCST MACRO - SDLC SUBAREA COMMUNICATION CONTROLLER LINKS ***
*****
*
N31PRI SDLCST MODE=PRI,GROUP=NTRINN
N31SEC SDLCST MODE=SEC,GROUP=NTRSEC
*
S31PRI SDLCST MODE=PRI,GROUP=A31GPRI
S31SEC SDLCST MODE=SEC,GROUP=A31GSEC
*
```

Figure A-4 (Part 5 of 46). NCP A31 Sample Generation Definition



## NCP A31 Sample Generation Definition

```
*****
* NCP POOL MACROS - USED FOR DYNAMIC RECONFIGURATION & SWITCHED SDLC *
*                               LINKS                               *
*****
*
*           PUDRPOOL NUMBER=50
*           LUDRPOOL NUMTYP1=02,NUMTYP2=100,NUMILU=100
*
*****
* NPA DEFINITION - NETWORK PERFORMANCE ANALYZER *
*****
*
A31NPAG GROUP LNCTL=SDLC,NPARSC=YES,VIRTUAL=YES
***
A31NPAL LINE
*
A31NPAP PU
*
A31NPLU1 LU
A31NPLU2 LU
A31NPLU3 LU
A31NPLU4 LU
A31NPLU5 LU
A31NPLU6 LU
A31NPLU7 LU
A31NPLU8 LU
*
*****
*           VIRTUAL DEFINITIONS FOR NRF R7 *
*****
*
A31NRF1 GROUP DIAL=NO, *
              LNCTL=SDLC, *
              MODETAB=NRFLOG, *
              PACING=0, *
              VIROWNER=CXRNRF, *
              VIRTUAL=YES, *
              VPACING=0
*
N31LINE LINE LINECB=CXRXLNK, *
          LINEFVT=CXRFVT, *
          LUFVT=(CXRFVT,CXRFVT), *
          PUFVT=CXRFVT
*

```

Figure A-4 (Part 6 of 46). NCP A31 Sample Generation Definition

## NCP A31 Sample Generation Definition

```
*****
* N31PU1 NRF SESSION PARTNER ROUTING *
*****
*
N31PU1  PU
*
N31LU1A LU  NRF.SESSPART=N31LU1D,NUMSESS=255,NRF.LUCAP=PRIMARY
N31LU1B LU  NRF.SESSPART=N31LU1F
N31LU1C LU  NRF.SESSPART=N31LU1G
N31LU1D LU  NRF.SESSPART=N31LU1A,NUMSESS=255
N31LU1F LU  NRF.SESSPART=N31LU1B
N31LU1G LU  NRF.SESSPART=N31LU1C
*
*****
* N31PU2 NRF TABLE, CORRELATION AND ARGUMENT ROUTING *
*****
*
N31PU2  PU
*
N31LU2A LU  NRF.ROUTE=FBTAB
N31LU2B LU  NRF.ROUTE=FBCTAB
N31LU2C LU  NRF.ROUTE=FBCTAB
N31LU2D LU  NRF.ROUTE=ARG1TB,NRF.LOCATE=LOCAT1
N31LU2F LU  NRF.CORRLTE=60,NRF.LOCATE=LOCAT2
N31LU2G LU  NRF.CORRLTE=60,NRF.LOCATE=LOCAT2
N31LU2H LU  NRF.CORRLTE=0,NRF.LOCATE=LOCAT2
N31LU2I LU  NRF.CORRLTE=0
*
*****
* N31PU3 NRF TABLE AND ARGUMENT ROUTING *
*****
*
N31PU3  PU
*
N31LU3A LU  NRF.ROUTE=FXTAB1
N31LU3B LU  NRF.ROUTE=FXTAB2,NRF.DEFAULT=N31LU2B
N31LU3C LU  NRF.ROUTE=FXTAB3,NRF.DEFAULT=N31LU2B
N31LU3D LU  NRF.ROUTE=FXTAB4
```

Figure A-4 (Part 7 of 46). NCP A31 Sample Generation Definition

## NCP A31 Sample Generation Definition

```
N31LU3E LU   NRF.ROUTE=FXTAB0,NRF.LUCAP=PRIMARY
N31LU3F LU   NRF.ROUTE=FXTABI,NRF.LUCAP=SECONDARY
N31LU3G LU   NRF.ROUTE=ARGTAB,NRF.LOCATE=LOCAT2
N31LU3H LU   NRF.ROUTE=ARGTAB,NRF.LOCATE=LOCAT2
N31LU3I LU   NRF.ROUTE=FXTABC
N31LU3J LU   NRF.ROUTE=FXTABN
*
*****
* N31PU4 NRF CORRELATION ROUTING *
*****
*
N31PU4   PU
*
N31LU4A LU   NRF.CORRLTE=60,NRF.DELAYTO=90,NRF.TAGLEN=2
*
FXTAB0  NRF.ROUTETAB
        NRF.ENTRY  ROUTDEST=N31LU3J
        NRF.TABEND
*
FXTABC  NRF.ROUTETAB
        NRF.ENTRY  ROUTDEST=N31LU3F
        NRF.TABEND
*
FXTABI  NRF.ROUTETAB
        NRF.ENTRY  ROUTDEST=N31LU3I
        NRF.TABEND
*
FXTAB1  NRF.ROUTETAB
        NRF.ENTRY  ROUTDEST=N31LU2F
        NRF.TABEND
*
FXTAB2  NRF.ROUTETAB
        NRF.ENTRY  ROUTDEST=N31LU2G
        NRF.TABEND
*
FXTAB3  NRF.ROUTETAB
        NRF.ENTRY  ROUTDEST=N31LU2H
        NRF.TABEND
*
```

Figure A-4 (Part 8 of 46). NCP A31 Sample Generation Definition

## NCP A31 Sample Generation Definition

```
FXTAB4  NRF.ROUTETAB
        NRF.ENTRY  ROUTDEST=N31LU4A
        NRF.TABEND
*
FBCTAB  NRF.ROUTETAB
        NRF.ENTRY  ROUTDEST=(N31LU2F,N31LU2G,N31LU2H,N31LU2I,N31LU4A)
        NRF.TABEND
*
FXTABN  NRF.ROUTETAB
        NRF.ENTRY  ROUTDEST=N31LU3E
        NRF.TABEND
*
ARGTAB  NRF.ROUTETAB
        NRF.ENTRY  ROUTEARG='C6C1'X,ROUTDEST=N31LU3I
        NRF.ENTRY  ROUTEARG='C6C2'X,ROUTDEST=N31LU3J
        NRF.ENTRY  ROUTEARG='C6C3'X,ROUTDEST=N31LU2A
        NRF.ENTRY  ROUTEARG='C6C4'X,ROUTDEST=N31LU2B
        NRF.TABEND
*
FBTAB   NRF.ROUTETAB
        NRF.ENTRY  ROUTDEST=(N31LU3E,N31LU3F,N31LU3G,N31LU3B,N31LU3C)
        NRF.TABEND
*
ARG1TB  NRF.ROUTETAB
        NRF.ENTRY  ROUTEARG='C6'X,
        ROUTDEST=(N31LU3E,N31LU3G,N31LU3H,N31LU2C,N31LU2G)
        NRF.ENTRY  ROUTEARG='C7'X,
        ROUTDEST=(N31LU3F,N31LU3H,N31LU2C,N31LU2G)
        NRF.ENTRY  ROUTEARG='C8'X,
        ROUTDEST=(N31LU3E,N31LU3G,N31LU2A,N31LU2H)
        NRF.ENTRY  ROUTEARG='C9'X,
        ROUTDEST=(N31LU3I,N31LU3G,N31LU3J,N31LU2B)
        NRF.TABEND
*
LOCAT1  NRF.LOCATE  FORMAT=(2,1)
LOCAT2  NRF.LOCATE  FORMAT=(2,2)
**
```

Figure A-4 (Part 9 of 46). NCP A31 Sample Generation Definition

## NCP A31 Sample Generation Definition

```
*****
*   FRAME RELAY BNN LINES   *
*****
*
A31FRYP0 GROUP FRELAY=(PHYSICAL,PER),          *
          LMI=ANSI,                          *
          MAXFRAME=2106,                      *
          TYPE=NCP,                          *
          DIAL=NO,                            *
          LNCTL=SDLC,                        *
          NPACOLL=(YES,EXTENDED),            *
          PUTYPE=1
*
A31F000  LINE ADDRESS=(000,FULL),             *
          NRZI=YES,                          *
          PORTADD=0,                         *
          SPEED=9600
*
A31PL000 PU ANS=CONT,                        *
          PUDR=NO,                          *
          NPACOLL=(YES,EXTENDED)
*
A31FRYL0 GROUP FRELAY=(LOGICAL,PERIPHERAL),  *
          AUTOGEN=10,                        *
          CALL=INOUT,                       *
          PHYSRSC=A31PL000,                 *
          T1TIMER=20,                      *
          TYPE=NCP,                          *
          DIAL=YES,                        *
          LNCTL=SDLC,                      *
          LEVEL2=ECLNAVL2,                  *
          LEVEL3=ECLNAVL3,                  *
          LEVEL5=NCP,                      *
          XIO=(ECLNAVXL,ECLNAVXS,ECLNAVXI,ECLNAVXK),
          LINEADD=NONE,                    *
          LINEAUT=YES,                      *
          NPACOLL=(YES,EXTENDED),          *
          PUTYPE=2,                        *
```

Figure A-4 (Part 10 of 46). NCP A31 Sample Generation Definition

## NCP A31 Sample Generation Definition

```

                                XMITDLY=NONE,
                                COMPSWP=NO,
                                COMPOWN=YES,
                                RETRIES=(6,0,0)
*
A31FRYP1 GROUP FRELAY=(PHYSICAL,PER),
                                LMI=ANSI,
                                MAXFRAME=2106,
                                TYPE=NCP,
                                DIAL=NO,
                                LNCTL=SDLC,
                                NPACOLL=(YES,EXTENDED),
                                PUTYPE=1
*
A31F032 LINE ADDRESS=(032,FULL),
                                NRZI=YES,
                                PORTADD=32,
                                SPEED=9600
*
A31PL032 PU ANS=CONT,
                                PUDR=NO,
                                NPACOLL=(YES,EXTENDED)
*
A31FRYL1 GROUP FRELAY=(LOGICAL,PERIPHERAL),
                                AUTOGEN=10,
                                CALL=INOUT,
                                PHYSRSC=A31PL032,
                                T1TIMER=20,
                                TYPE=NCP,
                                DIAL=YES,
                                LNCTL=SDLC,
                                LEVEL2=ECLNAVL2,
                                LEVEL3=ECLNAVL3,
                                LEVEL5=NCP,
                                XIO=(ECLNAVXL,ECLNAVXS,ECLNAVXI,ECLNAVXK),
                                LINEADD=NONE,
                                LINEAUT=YES,
                                NPACOLL=(YES,EXTENDED),
                                PUTYPE=2,
                                XMITDLY=NONE,
                                COMPSWP=NO,
                                COMPOWN=YES,
                                RETRIES=(6,0,0)
*
```

Figure A-4 (Part 11 of 46). NCP A31 Sample Generation Definition

## NCP A31 Sample Generation Definition

```
*****
* LINE 2368 - RVX LEASED 3767 (#22) *
*****
*
A31BNN2 GROUP ACTIVTO=420.0, *
          ANS=CONT, *
          CLOCKNG=EXT, *
          DIAL=NO, *
          DUPLEX=FULL, *
          LNCTL=SDLC, *
          MODETAB=MODSDLCT, *
          NRZI=NO, *
          REPLYTO=1, *
          RETRIES=(,3,5), *
          SPEED=1200, *
          TYPE=NCP, *
          USSTAB=HELLO
*
A31S2368 LINE ADDRESS=(2368,FULL), *
          ISTATUS=INACTIVE, *
          MAXPU=6
*
          SERVICE ORDER=(A31P68C1),MAXLIST=6
*
A31P68C1 PU ADDR=C1, *
          AVGPB=20, *
          DLOGMOD=M3767, *
          IRETRY=YES, *
          MAXDATA=256, *
          MAXOUT=2, *
          PASSLIM=2, *
          PUDR=NO, *
          PUTYPE=1
*
A31L681A LU LOCADDR=0
*
```

Figure A-4 (Part 12 of 46). NCP A31 Sample Generation Definition

## NCP A31 Sample Generation Definition

```
*****
**** SDLC LEASED RVX LINE PU T2'S -- 3276'S ****
*****
*
A31BNN3 GROUP ANS=CONT, *
          CLOCKNG=EXT, *
          DIAL=NO, *
          DUPLEX=FULL, *
          LNCTL=SDLC, *
          NRZI=YES, *
          SPEED=2400, *
          TYPE=NCP, *
          USSTAB=HELLO
*
*****
* ADDRESS 2369 - 3276'S *
*****
*
A31S2369 LINE ADDRESS=2369, *
          ISTATUS=INACTIVE, *
          LPDATS=LPDA2, *
          MAXPU=5, *
          RETRIES=(7,4,3)
*
          SERVICE ORDER=(A31P691,A31P692),MAXLIST=5
*
A31P691 PU ADDR=C1, *
          IRETRY=NO, *
          LPDA=ALLOW, *
          MAXDATA=265, *
          MAXOUT=2, *
          PASSLIM=2, *
          PUDR=YES, *
          PUTYPE=2, *
          SRT=(256,4)
*
A31D6911 LU LOCADDR=02, *
          PACING=1
*
A31D6912 LU LOCADDR=03, *
          PACING=1
*
```

Figure A-4 (Part 13 of 46). NCP A31 Sample Generation Definition



## NCP A31 Sample Generation Definition

```

A31P692  PU ADDR=C2, *
          IRETRY=NO, *
          MAXDATA=265, *
          MAXOUT=2, *
          PASSLIM=2, *
          PUDR=YES, *
          PUTYPE=2, *
          SRT=(256,4)
*
A31D6921 LU LOCADDR=02, *
          PACING=1
*
A31D6922 LU LOCADDR=03, *
          PACING=1
*
*****
* LINE 2374 - SWITCHED 3276 USING V25BIS=SDLC *
* SWITCHED MAJOR NODE IS V25SDLCB, LU IS A31L741A *
*****
*
A31BNN4  GROUP DIAL=YES, *
          LNCTL=SDLC, *
          REPLYTO=3, *
          TYPE=NCP, *
          USSTAB=HELLO, *
          V25BIS=(YES,DLS DLC), *
          XMITDLY=23.5
*
A31S2374 LINE ADDRESS=2374, *
          AUTO=YES, *
          CALL=INOUT, *
          CLOCKNG=EXT, *
          DATMODE=FULL, *
          DUPLEX=FULL, *
          PAUSE=1.0, *
          RETRIES=(,3,5), *

```

Figure A-4 (Part 14 of 46). NCP A31 Sample Generation Definition

## NCP A31 Sample Generation Definition

```

                                REDIAL=(,3,5),          *
                                RING=YES,                *
                                SPEED=1200,             *
                                V25BIS=(YES,DLS DLC)
*
A31P741  PU AVGPB=140,          *
          PUTYPE=(1,2)
*
*****
* SUBAREA LINK:  SDLC FOR PRIMARY/SECONDARY STATION *
*****
*
A31GPRI  GROUP ACTIVTO=60.0,    *
          DIAL=NO,                *
          LNCTL=SDLC,             *
          MODE=PRI,               *
          REPLYTO=30,             *
          TYPE=NCP
*
A31GSEC  GROUP ACTIVTO=60.0,    *
          DIAL=NO,                *
          LNCTL=SDLC,             *
          MODE=SEC,               *
          TYPE=NCP
*
*****
* SDLC SUBAREA LINES - 9.6 KBPS LINK - TGN=1 - LPDATS=LPDA2 TESTING *
*          CONNECT TO A04NCP LINE 001 OR LINE 033                    *
*****
*
A31GINN1 GROUP ANS=CONT,        *
          CLOCKNG=EXT,          *
          DIAL=NO,              *
          DUPLEX=FULL,          *
          LNCTL=SDLC,           *

```

Figure A-4 (Part 15 of 46). NCP A31 Sample Generation Definition

## NCP A31 Sample Generation Definition

```

LPDATS=LPDA2,
MONLINK=NO,
NRZI=YES,
REPLYTO=3,
RETRIES=(30,1,3),
SDLCST=(S31PRI,S31SEC),
TGCONF=MULTI,
TGN=1
*
*****
* SUBAREA LINE ADDRESS=001 FULL DUPLEX
*****
*
A31S01 LINE ADDRESS=(001,FULL),
      MLTGPRI=10
*
*
A31P01 PU LPDA=ALLOW,
      MAXDATA=5000,
      PUTYPE=4
*
*
*****
* SUBAREA LINE ADDRESS=033 FULL DUPLEX
*****
*
A31S33 LINE ADDRESS=(033,FULL),
      MLTGPRI=10
*
*
A31P33 PU LPDA=BLOCK,
      MAXDATA=5000,
      PUTYPE=4
*
*
*****
* SDLC SUBAREA LINES - 1.2 KBPS LINK - TGN=1 - V.25 BIS CONNECTION
*   CONNECT TO A04NCP LINE 002 OR 034 THROUGH V.25 BIS MODEMS
*   - FOR LINE 002 IN A04NCP USE SWITCHED MAJOR NODE A81SAD02
*   - FOR LINE 034 IN A04NCP USE SWITCHED MAJOR NODE A81SAD34
*****
*
```

Figure A-4 (Part 16 of 46). NCP A31 Sample Generation Definition

## NCP A31 Sample Generation Definition

```
A31GINN2 GROUP ACTIVTO=420.0, *
          DIAL=YES, *
          LNCTL=SDLC, *
          PUTYPE=4, *
          SDLCST=(S31PRI,S31SEC), *
          TGCONF=MULTI, *
          TYPE=NCP, *
          V25BIS=(YES,DLS DLC)
*
A31S02  LINE ADDRESS=002, *
          AUTO=YES, *
          CALL=INOUT, *
          CLOCKNG=EXT, *
          DUPLEX=FULL, *
          MLTGPRI=20, *
          SPEED=1200, *
          V25BIS=(YES,DLS DLC)
*
A31PU02  PU PUTYPE=4
*
A31S34  LINE ADDRESS=034, *
          AUTO=YES, *
          CALL=INOUT, *
          CLOCKNG=EXT, *
          DUPLEX=FULL, *
          MLTGPRI=20, *
          SPEED=1200, *
          V25BIS=(YES,DLS DLC)
*
A31PU34  PU PUTYPE=4
*
*****
* SDLC SUBAREA LINES - 9.6 KBPS LINK - TGN=1 - SWITCHED CONNECTION *
*   CONNECT TO A04NCP LINE 003 OR 035 THROUGH 9.6 KBPS MODEMS *
*   - FOR LINE 003 IN A04NCP USE SWITCHED MAJOR NODE A81SAD03 *
*   - FOR LINE 035 IN A04NCP USE SWITCHED MAJOR NODE A81SAD35 *
*****
*
```

Figure A-4 (Part 17 of 46). NCP A31 Sample Generation Definition

## NCP A31 Sample Generation Definition

```

A31GINN3 GROUP ACTIVTO=420.0,          *
          DIAL=YES,                    *
          LNCTL=SDLC,                  *
          PUTYPE=4,                    *
          SDLCST=(S31PRI,S31SEC),      *
          TGCONF=MULTI,                *
          TYPE=NCP
*
A31S03  LINE ADDRESS=003,              *
          AUTO=010,                    *
          CALL=INOUT,                  *
          CLOCKNG=EXT,                 *
          DUPLEX=HALF,                 *
          MLTGPRI=30,                  *
          SPEED=9600
*
A31PU03  PU PUTYPE=4
*
A31S35  LINE ADDRESS=035,              *
          AUTO=042,                    *
          CALL=INOUT,                  *
          CLOCKNG=EXT,                 *
          DUPLEX=HALF,                 *
          MLTGPRI=30,                  *
          SPEED=9600
*
A31PU35  PU PUTYPE=4
*
*****
* SDLC SUBAREA LINES - 56 Kbps LINK - TGN=1 CONNECTION FOR MIGRATION *
*          CONNECT TO A04NCP LINE 020 OR 052                          *
*****
*
A31GINN4 GROUP ANS=CONT,               *
          CLOCKNG=EXT,                 *
          DIAL=NO,                     *
          DUPLEX=FULL,                 *

```

Figure A-4 (Part 18 of 46). NCP A31 Sample Generation Definition

## NCP A31 Sample Generation Definition

```

LNCTL=SDLC,
MONLINK=NO,
NRZI=YES,
REPLYTO=3,
RETRIES=(30,1,3),
SDLCST=(S31PRI,S31SEC),
TGCONF=MULTI,
TGN=1
*
*****
* SUBAREA LINE ADDRESS=020 FULL DUPLEX
*****
*
A31S20 LINE ADDRESS=(020,FULL),
MLTGPRI=40
*
*
A31P20 PU MAXDATA=5000,
PUTYPE=4
*
*
*****
* SUBAREA LINE ADDRESS=052 FULL DUPLEX
*****
*
A31S52 LINE ADDRESS=(052,FULL),
MLTGPRI=40
*
*
A31P52 PU MAXDATA=5000,
PUTYPE=4
*
*
*****
* SDLC RVX SUBAREA LINES - 9.6 KBPS LEASED LINK - TGN=1
*
* CONNECT TO A04NCP LINE 2371
*
*****
*
A31GINN5 GROUP ANS=CONT,
CLOCKNG=EXT,
DIAL=NO,
DUPLICATE=FULL,
LNCTL=SDLC,
MONLINK=NO,
NRZI=YES,
REPLYTO=3,
RETRIES=(30,1,3),
SDLCST=(S31PRI,S31SEC),
SPEED=9600,
TGCONF=MULTI,
TGN=1
*

```

Figure A-4 (Part 19 of 46). NCP A31 Sample Generation Definition

## NCP A31 Sample Generation Definition

```
*****
* SUBAREA LINE ADDRESS=2370 FULL DUPLEX *
*****
*
A31S2370 LINE ADDRESS=(2370,FULL), *
          MLTGPRI=10
*
A31P2370 PU MAXDATA=5000, *
          PUTYPE=4
*
*****
* SDLC RVX SUBAREA LINES - 9.6 KBPS SWITCHED LINK - TGN=1 *
*   CONNECT TO A04NCP LINE 2373 THROUGH SWITCHED MODEMS *
*****
*
A31GINN6 GROUP ANS=CONT, *
               CLOCKNG=EXT, *
               DIAL=NO, *
               DUPLEX=HALF, *
               LNCTL=SDLC, *
               MONLINK=NO, *
               NRZI=YES, *
               REPLYTO=3, *
               RETRIES=(30,1,3), *
               SDLCST=(S31PRI,S31SEC), *
               SPEED=9600, *
               TGCONF=MULTI, *
               TGN=1
*
*****
* SUBAREA LINE ADDRESS=2372 HALF DUPLEX *
*****
*
A31S2372 LINE ADDRESS=2372, *
          CONFIG=SW, *
          MLTGPRI=10
*
A31P2372 PU MAXDATA=5000, *
          PUTYPE=4
*
```

Figure A-4 (Part 20 of 46). NCP A31 Sample Generation Definition

## NCP A31 Sample Generation Definition

```
*****
* SDLC SUBAREA RVX LINE - 1.2 KBPS - TGN=1 - V.25 BIS CONNECTION *
*      CONNECT TO A04NCP LINE 2380 THROUGH V.25 BIS MODEMS      *
*      USE SWITCHED MAJOR NODE A81SAD80                          *
*****
*
A31GINN7 GROUP ACTIVTO=420.0, *
      DIAL=YES, *
      LNCTL=SDLC, *
      PUTYPE=4, *
      SDLCST=(S31PRI,S31SEC), *
      TGCONF=MULTI, *
      TYPE=NCP, *
      V25BIS=(YES,DLSDLC)
*
A31S2379 LINE ADDRESS=2379, *
      AUTO=YES, *
      CALL=INOUT, *
      CLOCKNG=EXT, *
      DUPLEX=FULL, *
      MLTGPRI=20, *
      SPEED=1200, *
      V25BIS=(YES,DLSDLC)
*
A31P2379 PU PUTYPE=4
*
*****
* SDLC SUBAREA RVX LINES - TGN=1 CONNECTION *
*****
*
A31GINN8 GROUP ANS=CONT, *
      CLOCKNG=EXT, *
      DIAL=NO, *
      DUPLEX=FULL, *
      LNCTL=SDLC, *
      MONLINK=NO, *
      NRZI=YES, *
      REPLYTO=3, *
      RETRIES=(30,1,3), *
      SDLCST=(S31PRI,S31SEC), *
      TGCONF=MULTI, *
      TGN=1
*

```

Figure A-4 (Part 21 of 46). NCP A31 Sample Generation Definition



## NCP A31 Sample Generation Definition

```

*****
* SDLC RVX SUBAREA LINE ADDRESS=2432 - 56KB LINK TO A04NCP LINE 2436 *
*****
*
A31S2432 LINE ADDRESS=(2432,FULL), *
          ADDIFG=YES, *
          MLTGPRI=40, *
          SPEED=56000, *
          TGN=1
*
A31P2432 PU MAXDATA=6000, *
          PUTYPE=4
*
*****
* SDLC RVX SUBAREA LINE ADDRESS=2496 - T1 LINK TO A04NCP LINE 2528 *
*****
*
A31S2496 LINE ADDRESS=(2496,FULL), *
          SPEED=1544000, *
          TGN=1
*
A31P2496 PU MAXDATA=6000, *
          PUTYPE=4
*
*****
* FRAME RELAY PHYSICAL GROUP FOR ODLC FRAME RELAY LINE 2468 *
*****
A310FRP1 GROUP FRELAY=PHYSICAL, *
          TYPE=NCP, *
          DIAL=NO, *
          LNCTL=SDLC, *
          NPACOLL=(YES,EXTENDED), *
          PUTYPE=1
*
A31S2468 LINE ADDRESS=(2468,FULL), *
          CLOCKNG=EXT, *
          DATABLK=2048, *
          PORTADD=68, *
          SPEED=56000
A31P2468 PU ANS=CONTINUE, *
          INNPORT=YES, *
          LMI=ANSI, *
          PUDR=NO, *
          NPACOLL=(YES,EXTENDED)

```

Figure A-4 (Part 22 of 46). NCP A31 Sample Generation Definition

## NCP A31 Sample Generation Definition

```
*****
* FRAME RELAY SUBAREA LOGICALS FOR 2468 *
*****
A310FRL1 GROUP FRELAY=(LOGICAL,SUBAREA), *
        PHYSRSC=A31P2468, *
        SDLCST=(S31PRI,S31SEC), *
        TYPE=NCP, *
        DIAL=NO, *
        LNCTL=SDLC, *
        NPACOLL=(YES,EXTENDED), *
        PUTYPE=4, *
        RETRIES=(6,0,0)
*
A31LL68A LINE COMRATE=(NONE,2)
A31PL68A PU PUTYPE=4, *
        TGN=1, *
        DLCI=(17,D), *
        NPACOLL=NO
*
A31LL68B LINE COMRATE=(NONE,8)
A31PL68B PU PUTYPE=4, *
        TGN=1, *
        DLCI=(18,D), *
        NPACOLL=NO
*
*****
* ISDN PHYSICAL LINE 2720 *
*****
A31IPHY1 GROUP ISDN=PHYSICAL, *
        ISTATUS=ACTIVE, *
        ISDNCFG=NOCRC, *
        DIAL=NO, *
        LNCTL=SDLC, *
        SPEED=2048000, *
        PUTYPE=1, *
        PUDR=NO
*
```

Figure A-4 (Part 23 of 46). NCP A31 Sample Generation Definition

## NCP A31 Sample Generation Definition

```

A31I2720 LINE ADDRESS=(2720,FULL),
                CLOCKNG=EXT,
                ISDNLPN=8032373238,
                LMI=ANSI,
                PORTADD=28,
                XMONLNK=YES,
                NRZI=NO,
                SPEED=2048000
A31P2720 PU ANS=CONTINUE,
                ADDR=01,
                INNPORT=YES
*
*****
* ISDN B CHANNEL DEFINITIONS FOR LINE 2720
*****
A31ICHN1 GROUP ISDN=(LOGICAL,B),
                PHYSRSC=A31P2720,
                XMONLNK=YES,
                DIAL=YES,
                LNCTL=SDLC,
                SPEED=64000,
                PUTYPE=1
*
A31I2721 LINE ADDRESS=(2721,FULL),
                CALL=IN,
                ID=07102721
N71P2721 PU ANS=CONTINUE,
                INNPORT=YES
*
N71I2722 LINE ADDRESS=(2722,FULL),
                CALL=IN,
                ID=07102722
N71P2722 PU ANS=CONTINUE,
                INNPORT=YES
*
*****
* ISDN BNN LOGICAL LINES
*****
A31ISBG1 GROUP ISDN=(LOGICAL,PER),
                PHYSRSC=NONE,
                PUTYPE=2,
                CALL=INOUT,
                DIAL=YES,
                LNCTL=SDLC,
                LINEAUT=YES,
                RETRIES=(6,0,0)
*
A31IBL01 LINE ADDRESS=NONE
A31IBP01 PU PUTYPE=2
*

```

Figure A-4 (Part 24 of 46). NCP A31 Sample Generation Definition

## NCP A31 Sample Generation Definition

```
*****
* ISDN INN LOGICAL LINES
*****
A31ISIG1 GROUP ISDN=(LOGICAL,SUB),
    PHYSRSC=NONE,
    PUTYPE=4,
    SDLCST=(S31PRI,S31SEC),
    CALL=INOUT,
    RETRIES=(15,0,0),
    DIAL=YES,
    LNCTL=SDLC,
    LINEAUT=YES
*
*
A31IIL01 LINE ADDRESS=NONE
A31IIP01 PU PUTYPE=4
*
*****
*          CASUAL CONNECT OVER SWITCHED LINE
* CONNECT TO A04NCP LINE 004, OR LINE 036 THROUGH SWITCHED MODEMS
*   - FOR LINE 004 IN A04NCP USE SWITCHED MAJOR NODE A81CCN04
*   - FOR LINE 036 IN A04NCP USE SWITCHED MAJOR NODE A81CCN36
*****
*
A31CCNG1 GROUP DIAL=YES,CALL=INOUT,
    LNCTL=SDLC,
    REPLYTO=3,
    TYPE=NCP,
    XMITDLY=23.5
*
*
A31CCN04 LINE ADDRESS=(004,HALF),
    AUTO=011,
    CALL=INOUT,
    CLOCKNG=EXT,
    DUPLEX=HALF,
    PAUSE=1.0,
    ROLE=NEG
*
*
A31PC41 PU AVGPB=140,
    PUTYPE=2,
    XID=YES
*
*

```

Figure A-4 (Part 25 of 46). NCP A31 Sample Generation Definition

## NCP A31 Sample Generation Definition

```

A31CCN36 LINE ADDRESS=(036,HALF),
          AUTO=043,
          CALL=INOUT,
          CLOCKNG=EXT,
          DUPLEX=HALF,
          PAUSE=1.0,
          ROLE=NEG
*
A31PC361 PU AVGPB=140,
          PUTYPE=2,
          XID=YES
*
*****
*   LEASED 56 KBPS PERIPHERAL - CASUAL CONNECTION TO A04NCP
*   CONNECTS TO LINE 016 OR 048
*****
*
A31CCNG2 GROUP ACTIVTO=100.0,
          DIAL=NO,
          LNCTL=SDLC,
          REPLYTO=5,
          TEXTTO=3,
          TYPE=NCP
*
A31CCN16 LINE ADDRESS=(016,FULL),
          CLOCKNG=EXT,
          DUPLEX=HALF,
          ISTATUS=ACTIVE,
          MAXPU=1,
          NRZI=NO,
          PAUSE=1.0,
          RETRIES=(5),
          SPEED=56000
*
          SERVICE ORDER=(A31PC161),MAXLIST=1
*
A31PC161 PU ADDR=C1,
          IRETRY=YES,
          MAXDATA=6000,
          MODULO=128,
          PUTYPE=2,
          PASSLIM=12,
          RETRIES=(,3,5),
          XID=YES
*

```

Figure A-4 (Part 26 of 46). NCP A31 Sample Generation Definition

## NCP A31 Sample Generation Definition

```

APPL02B LU LOCADDR=0, *
          PACING=(1)
*
APPL02C LU LOCADDR=0, *
          PACING=(1)
*
A31CCN48 LINE ADDRESS=(048,FULL), *
          CLOCKNG=EXT, *
          DUPLEX=HALF, *
          ISTATUS=ACTIVE, *
          MAXPU=1, *
          NRZI=NO, *
          PAUSE=1.0, *
          RETRIES=(5), *
          SPEED=56000
*
          SERVICE ORDER=(A31PC481),MAXLIST=1
*
A31PC481 PU ADDR=C1, *
          IRETRY=YES, *
          MAXDATA=6000, *
          MODULO=128, *
          PUTYPE=2, *
          PASSLIM=12, *
          RETRIES=(,3,5), *
          XID=YES
*
APPL02B1 LU LOCADDR=0, *
          PACING=(1)
*
APPL02C1 LU LOCADDR=0, *
          PACING=(1)
*
*****
*          CASUAL CONNECT OVER SWITCHED RVX LINE *
*          CONNECT TO A04NCP LINE 2378 *
*          USE SWITCHED MAJOR NODE A81CCN78 *
*****
*
A31CCNG3 GROUP DIAL=YES,CALL=INOUT, *
          LNCTL=SDLC, *
          REPLYTO=3, *
          SPEED=4800, *
          TYPE=NCP, *
          XMITDLY=23.5

```

Figure A-4 (Part 27 of 46). NCP A31 Sample Generation Definition

## NCP A31 Sample Generation Definition

```

*
A31CCN77 LINE ADDRESS=(2377,HALF),
                CALL=INOUT,
                CLOCKNG=EXT,
                DUPLEX=HALF,
                PAUSE=1.0,
                ROLE=NEG
*
*
A31PC771 PU AVGPB=140,
          PUTYPE=2,
          XID=YES
*
*****
*   LEASED RVX 56 KBPS PERIPHERAL - CASUAL CONNECTION TO A04NCP
*   CONNECTS TO LINE 2444
*****
*
A31CCNG4 GROUP ACTIVTO=100.0,
            DIAL=NO,
            LNCTL=SDLC,
            REPLYTO=5,
            TEXTTO=3,
            TYPE=NCP
*
*
A31CCN40 LINE ADDRESS=(2440,FULL),
            CLOCKNG=EXT,
            DUPLEX=HALF,
            ISTATUS=ACTIVE,
            MAXPU=1,
            NRZI=NO,
            PAUSE=1.0,
            RETRIES=(5),
            SPEED=56000
*
          SERVICE ORDER=(A31PC401),MAXLIST=1
*
A31PC401 PU ADDR=C1,
          IRETRY=YES,
          MAXDATA=6000,
          MODULO=128,
          PUTYPE=2,
          PASSLIM=12,
          RETRIES=(,3,5),
          XID=YES

```

Figure A-4 (Part 28 of 46). NCP A31 Sample Generation Definition

## NCP A31 Sample Generation Definition

```

*
APPL02D LU LOCADDR=0,
          PACING=(1)
*
*
APPL02E LU LOCADDR=0,
          PACING=(1)
*
54950000
*
*****
* NCP/TOKEN RING INTERCONNECT - PHYSICAL CONNECTIONS *
*****
*
A31NTR1 GROUP ADAPTER=TIC2,
              ANS=CONTINUE,
              ECLTYPE=(PHYSICAL,ANY),
              NPACOLL=(YES,EXTENDED),
              TRSPEED=4,
              USSTAB=AUSSTAB,
              XID=NO,
              TYPE=NCP,
              DIAL=NO,
              LNCTL=SDLC,
              LEVEL2=ECLNARL2,
              LEVEL3=ECLNARL3,
              LEVEL5=NCP,
              TIMER=(ECLNART1,,ECLNART2,ECLNART3),
              XIO=(ECLNARXL,ECLNARXS,ECLNARXI,ECLNARXK),
              USERID=(5668854,ECLRBDT,NORECMS,,ECLNMVT),
              SPEED=9600,
              PUTYPE=1,
              PUDR=NO,
              COMPTAD=YES,
              COMPSWP=YES,
              COMPOWN=YES
*
*
*****
* NTRI SUBAREA AND PERIPHERAL MIXED PHYSICAL CONNECTIONS *
*****
*
A31TR88 LINE ADDRESS=(1088,FULL),
          LOCADD=400000003131,
          MAXTSL=4060,
          PORTADD=1,
          RCVBUFC=32000,
          UACB=(X$P1AX,X$P1AR)

```

Figure A-4 (Part 29 of 46). NCP A31 Sample Generation Definition



## NCP A31 Sample Generation Definition

```

*
A31PU88  PU ADDR=01,                                     *
          INNPORT=YES
*
A31TR92  LINE ADDRESS=(1092,FULL),                       *
          LOCADD=400000003135,                           *
          MAXTSL=4060,                                    *
          PORTADD=5,                                      *
          RCVBUFC=32000,                                  *
          UACB=(X$P2AX,X$P2AR)
*
A31PU92  PU ADDR=01,                                     *
          INNPORT=YES
*
*****
*
A31PGRP2 GROUP ADAPTER=TIC2,                             *
               ANS=STOP,                                  *
               ECLTYPE=(PHYSICAL,PER),                   *
               NPACOLL=(YES,EXTENDED),                   *
               TRSPEED=16,                                *
               USSTAB=AUSSTAB,                           *
               XID=NO,                                    *
               TYPE=NCP,                                  *
               DIAL=NO,                                    *
               LNCTL=SDLC,                                 *
               LEVEL2=ECLNARL2,                           *
               LEVEL3=ECLNARL3,                           *
               LEVEL5=NCP,                                 *
               TIMER=(ECLNART1,,ECLNART2,ECLNART3),      *
               XIO=(ECLNARXL,ECLNARXS,ECLNARXI,ECLNARXK), *
               USERID=(5668854,ECLRBDT,NORECMS,,ECLNMVT), *
               SPEED=9600,                                *
               PUTYPE=1,                                   *
               PUDR=NO,                                    *
               COMPTAD=YES,                                *
               COMPSWP=YES,                                *
               COMPOWN=YES
*

```

Figure A-4 (Part 30 of 46). NCP A31 Sample Generation Definition

## NCP A31 Sample Generation Definition

```
*****
* NTRI PERIPHERAL PHYSICAL CONNECTIONS - SAME LOCADD AS NTRI *
* PERIPHERAL IN A04NCP *
*****
*
A31TR89 LINE ADDRESS=(1089,FULL), *
        LOCADD=40000000032, *
        MAXTSL=16384, *
        PORTADD=2, *
        RCVBUFC=32000, *
        UACB=(X$P3AX,X$P3AR)
*
A31PU89 PU ADDR=01
*
A31TR93 LINE ADDRESS=(1093,FULL), *
        LOCADD=40000000036, *
        MAXTSL=16384, *
        PORTADD=6, *
        RCVBUFC=32000, *
        UACB=(X$P4AX,X$P4AR)
*
A31PU93 PU ADDR=01
*
*****
* NTRI - LOGICAL CONNECTIONS *
*****
*
*
*****
* NTRI PERIPHERAL LOGICAL LINES - GENERATED IN NEWDEFN *
* USED WITH A31TR88, A31TR89, A31TR92, AND/OR A31TR93 *
*****
*
A31BNG1 GROUP ANS=CONTINUE, *
        AUTOGEN=20, *
        CALL=INOUT, *
        ECLTYPE=LOGICAL, *
        ISTATUS=ACTIVE, *
        MODETAB=AMODETAB, *
        NPACOLL=(YES,EXTENDED), *
        PHYPORT=NONE, *
        RETRIES=(10,10,10,10), *
        USSTAB=AUSSTAB, *
        XMITDLY=NONE, *
        TYPE=NCP, *
        DIAL=YES, *
        LNCTL=SDLC, *
        LEVEL2=ECLNAVL2, *
```

Figure A-4 (Part 31 of 46). NCP A31 Sample Generation Definition

## NCP A31 Sample Generation Definition

```

LEVEL3=ECLNAVL3,
LEVEL5=NCP,
XIO=(ECLNAVXL,ECLNAVXS,ECLNAVXI,ECLNAVXK),
USERID=(5668854,ECLVBDT,NORECMS,,ECLNMVT),
LINEADD=NONE,
LINEAUT=YES,
PUTYPE=2,
COMPOWN=YES
*
*****
* SDLC GROUP FOR PRIMARY/SECONDARY STATION *
*****
*
NTRINN GROUP ACTIVTO=420,
DIAL=NO,
LNCTL=SDLC,
MODE=PRI,
REPLYTO=3
*
NTRSEC GROUP ACTIVTO=420,
DIAL=NO,
LNCTL=SDLC,
MODE=SEC
*
*****
* GROUP FOR NTRI SUBAREA LOGICAL LINE - ASSOCIATED WITH A31TR88 *
*****
*
A31INNG1 GROUP ANS=CONTINUE,
ECLTYPE=(LOGICAL,SUBAREA),
MAXOUT=3,
MODETAB=AMODETAB,
NPACOLL=(YES,EXTENDED),
PHYPORT=1,
SDLCST=(N31PRI,N31SEC),
TGCONF=MULTI,
USSTAB=AUSSTAB,
TYPE=NCP,
DIAL=NO,
LNCTL=SDLC,
LEVEL2=ECLNAVL2,
LEVEL3=ECLNAVL3,
LEVEL5=NCP,
XIO=(ECLNAVXL,ECLNAVXS,ECLNAVXI,ECLNAVXK),
USERID=(5668854,ECLVBDT,NORECMS,,ECLNMVT),

```

Figure A-4 (Part 32 of 46). NCP A31 Sample Generation Definition

## NCP A31 Sample Generation Definition

```
LINEADD=NONE, *
PUTYPE=4, *
COMPOWN=YES, *
RETRIES=(6,0,0,6)
*
*****
* NTRI SUBAREA LOGICAL CONNECTION TO NCP A04NCP -- TGN=1 *
*****
*
A31LG1A LINE MLTGPRI=50, *
        TGN=1, *
        UACB=X$L21A
*
A31PG1A PU ADDR=0440000000431, *
        MAXDATA=5000
*
*****
* LOGICAL CONNECTION TO 3172 *
*****
*
A31LG2A LINE TGN=1, *
        UACB=X$L22A
*
A31PG2A PU ADDR=10400000009999
*
*****
* NTRI SUBAREA LOGICAL CONNECTION TO NCP A04NCP -- TGN=1 *
*****
*
A31LG3A LINE MLTGPRI=50, *
        TGN=1, *
        UACB=X$L23A
*
A31PG3A PU ADDR=0440000000435, *
        MAXDATA=5000
*
*****
* GROUP FOR NTRI SUBAREA LOGICAL LINE - ASSOCIATED WITH A31TR92 *
*****
*
A31INNG2 GROUP ANS=CONTINUE, *
              ECLTYPE=(LOGICAL,SUBAREA), *
              MAXOUT=3, *
              MODETAB=AMODETAB, *
              NPACOLL=(YES,EXTENDED), *
              PHYPORT=5, *
```

Figure A-4 (Part 33 of 46). NCP A31 Sample Generation Definition

## NCP A31 Sample Generation Definition

```

SDLCST=(N31PRI,N31SEC),
TGCONF=MULTI,
USSTAB=AUSSTAB,
TYPE=NCP,
DIAL=NO,
LNCTL=SDLC,
LEVEL2=ECLNAVL2,
LEVEL3=ECLNAVL3,
LEVEL5=NCP,
XIO=(ECLNAVXL,ECLNAVXS,ECLNAVXI,ECLNAVXK),
USERID=(5668854,ECLVBDT,NORECMS,,ECLNMVT),
LINEADD=NONE,
PUTYPE=4,
COMPOWN=YES,
RETRIES=(6,0,0,6)
*
*****
* NTRI SUBAREA LOGICAL CONNECTION TO NCP A04NCP -- TGN=1 *
*****
*
A31LG1B LINE MLTGPRI=50,
          TGN=1,
          UACB=X$L24A
*
*
A31PG1B PU ADDR=0440000000431,
          MAXDATA=5000
*
*
*****
* LOGICAL CONNECTION TO 3172 *
*****
*
A31LG2B LINE TGN=1,
          UACB=X$L25A
*
*
A31PG2B PU ADDR=10400000009999
*
*
*****
* NTRI SUBAREA LOGICAL CONNECTION TO NCP A04NCP -- TGN=1 *
*****
*
A31LG3B LINE MLTGPRI=50,
          TGN=1,
          UACB=X$L26A
*
*
A31PG3B PU ADDR=0440000000435,
          MAXDATA=5000
*

```

Figure A-4 (Part 34 of 46). NCP A31 Sample Generation Definition

## NCP A31 Sample Generation Definition

```
*****
*
*           37CS PHYSICAL CONNECTIONS
*
*****
*
A3137CS  GROUP ADAPTER=TIC3,
          ANS=CONTINUE,
          ECLTYPE=(PHYSICAL,ANY),
          ISTATUS=ACTIVE,
          TRSPEED=16,
          USSTAB=AUSSTAB,
          XID=NO,
          TYPE=NCP,
          DIAL=NO,
          LNCTL=SDLC,
          SPEED=9600,
          NPACOLL=NO,
          PUTYPE=1,
          PUDR=NO
*
A31L2144 LINE ADDRESS=(2144,FULL),
          LOCADD=40000007041,
          MAXTSL=3500,
          PORTADD=10,
          TRSPEED=16,
          XMONLNK=YES
*
A31P2144 PU PUTYPE=1,
          ADDR=01,
          INNPORT=YES
*
*****
*           37CS PERIPHERAL LOGICAL LINES
*
*****
*
A31BNG2  GROUP ANS=CONTINUE,
          AUTOGEN=3,
          CALL=INOUT,
          ECLTYPE=(LOGICAL,PER),
          ISTATUS=ACTIVE,
          MODETAB=AMODETAB,
          *
```

Figure A-4 (Part 35 of 46). NCP A31 Sample Generation Definition

## NCP A31 Sample Generation Definition

```

        PHYSRSC=A31P2144,
        USSTAB=AUSSTAB,
        TYPE=NCP,
        DIAL=YES,
        LNCTL=SDLC,
        LINEAUT=YES,
        NPACOLL=NO,
        PUTYPE=2,
        RETRIES=(3,2,1,6)
*
*****
*  ALLOWS SUBAREA TRAFFIC BETWEEN THE 37CS 2144 LINE AND LINES 1088,
*  1092, OR 2080 OF A04NCP
*****
*
A31INNG3 GROUP ANS=CONTINUE,
               ECLTYPE=(LOGICAL,SUBAREA),
               IPL=YES,
               ISTATUS=ACTIVE,
               MAXOUT=3,
               MODETAB=AMODETAB,
               MONLINK=YES,
               PHYSRSC=A31P2144,
               SDLCST=(,N31SEC),
               TGCONF=MULTI,
               USSTAB=AUSSTAB,
               TYPE=NCP,
               DIAL=NO,
               LNCTL=SDLC,
               NPACOLL=NO,
               PUTYPE=4,
               RETRIES=(3,2,1,6)
*
A31LG1C  LINE MLTGPRI=60,
          TGN=1
*
A31PG1C  PU ADDR=04400000009021,
          MAXDATA=5000
*
A31LG2C  LINE MLTGPRI=60,
          TGN=1

```

Figure A-4 (Part 36 of 46). NCP A31 Sample Generation Definition

# NCP A31 Sample Generation Definition

```
*
A31PG2C  PU ADDR=04400000000431,
          MAXDATA=5000
*
*
A31LG3C  LINE MLTGPRI=60,
          TGN=1
*
*
A31PG3C  PU ADDR=04400000000435,
          MAXDATA=5000
*
*****
*
*   PHYSICAL ESCON CHANNEL DEFINITIONS
*
*****
*
G31RSOC1 GROUP LNCTL=CA,
          SPEED=144000000,
          SRT=(32768,32768),
          XMONLNK=YES
*
*
A31S2240 LINE ADDRESS=2240          ESCON PHYSICAL CHANNEL ON LIM-5A
*
A31P2240 PU ANS=CONTINUE,
          PUTYPE=1
*
*
A31S2304 LINE ADDRESS=2304          ESCON PHYSICAL CHANNEL ON LIM-6A
*
A31P2304 PU ANS=CONTINUE,
          PUTYPE=1
*
*****
*
*   LOGICAL ESCON CHANNEL DEFINITIONS
*
*****
*
*   ESCON LOGICAL RESOURCES ASSOCIATED WITH PHYSICAL LINE 1 (2240)
*
*****
*
```

Figure A-4 (Part 37 of 46). NCP A31 Sample Generation Definition



## NCP A31 Sample Generation Definition

```

G31LSOC1 GROUP CASDL=0.0, *
                DELAY=0.2, *
                LNCTL=CA, *
                MAXPU=16, *
                PHYRSC=A31P2240, *
                PUDR=YES, *
                SPEED=144000000, *
                SRT=(20000,20000), *
                TIMEOUT=840.0, *
                TRANSFR=200 *
*
*****
*   ESCON LOGICAL LINE 1 GROUP 1 (ESCON PHYSICAL CHANNEL 2240)   *
*****
*
A31S1L1  LINE ADDRESS=NONE,          ESCON PHYSICAL CHANNEL 2240 *
                HOSTLINK=1,          LOGICAL LINE 1 *
                MONLINK=NO
*
A31S1P11 PU ADDR=01, *
                ANS=CONTINUE, *
                PUDR=NO, *
                PUTYPE=5, *
                TGN=1
*
A31S1P12 PU ADDR=02, *
                ANS=CONTINUE, *
                PUDR=NO, *
                PUTYPE=5, *
                TGN=1
*
A31S1P13 PU ADDR=03, *
                ANS=STOP, *
                PUDR=YES, *
                PUTYPE=2
*
BS1P13L1 LU LOCADDR=0
*

```

Figure A-4 (Part 38 of 46). NCP A31 Sample Generation Definition

## NCP A31 Sample Generation Definition

```
A31S1P14 PU ADDR=04, *
                ANS=STOP, *
                PUDR=YES, *
                PUTYPE=2
*
BS1P14L1 LU LOCADDR=0
*
*****
*   ESCON LOGICAL LINE 2 GROUP 1 (ESCON PHYSICAL CHANNEL 2240) *
*****
*
A31S1L2  LINE ADDRESS=NONE,          ESCON PHYSICAL CHANNEL 2240 *
                HOSTLINK=2,          LOGICAL LINE 2 *
                MONLINK=NO
*
A31S1P21 PU ADDR=01, *
                ANS=CONTINUE, *
                PUDR=NO, *
                PUTYPE=5, *
                TGN=1
*
A31S1P22 PU ADDR=02, *
                ANS=CONTINUE, *
                PUDR=NO, *
                PUTYPE=5, *
                TGN=1
*
A31S1P23 PU ADDR=03, *
                ANS=STOP, *
                PUDR=YES, *
                PUTYPE=2
*
```

Figure A-4 (Part 39 of 46). NCP A31 Sample Generation Definition

## NCP A31 Sample Generation Definition

```

BS1P23L1 LU LOCADDR=0
*
A31S1P24 PU ADDR=04, *
                ANS=STOP, *
                PUDR=YES, *
                PUTYPE=2
*
BS1P24L1 LU LOCADDR=0
*
*****
*   ESCON LOGICAL LINE 3 GROUP 1 (ESCON PHYSICAL CHANNEL 2240) *
*****
*
A31S1L3  LINE ADDRESS=NONE,          ESCON PHYSICAL CHANNEL 2240 *
                HOSTLINK=3,          LOGICAL LINE 3 *
                MONLINK=YES
*
A31S1P31 PU ADDR=01, *
                ANS=CONTINUE, *
                PUDR=NO, *
                PUTYPE=5, *
                TGN=1
*
A31S1P32 PU ADDR=02, *
                ANS=CONTINUE, *
                PUDR=NO, *
                PUTYPE=5, *
                TGN=1
*
A31S1P33 PU ADDR=03, *
                ANS=STOP, *
                PUDR=YES, *
                PUTYPE=2
*
BS1P33L1 LU LOCADDR=0
*
A31S1P34 PU ADDR=04, *
                ANS=STOP, *
                PUDR=YES, *
                PUTYPE=2
*
BS1P34L1 LU LOCADDR=0
*

```

Figure A-4 (Part 40 of 46). NCP A31 Sample Generation Definition

## NCP A31 Sample Generation Definition

```

*****
*   ESCON LOGICAL LINE 4 GROUP 1 (ESCON PHYSICAL CHANNEL 2240)   *
*****
*
A31S1L4  LINE ADDRESS=NONE,          ESCON PHYSICAL CHANNEL 2240  *
          HOSTLINK=4,                LOGICAL LINE 4              *
          MONLINK=YES
*
A31S1P41 PU ADDR=01,                *
          ANS=CONTINUE,              *
          PUDR=NO,                   *
          PUTYPE=5,                   *
          TGN=1
*
A31S1P42 PU ADDR=02,                *
          ANS=CONTINUE,              *
          PUDR=NO,                   *
          PUTYPE=5,                   *
          TGN=1
*
A31S1P43 PU ADDR=03,                *
          ANS=STOP,                  *
          PUDR=YES,                  *
          PUTYPE=2
*
BS1P43L1 LU LOCADDR=0
*
A31S1P44 PU ADDR=04,                *
          ANS=STOP,                  *
          PUDR=YES,                  *
          PUTYPE=2
*
BS1P44L1 LU LOCADDR=0
*
*****
*   ESCON LOGICAL RESOURCES ASSOCIATED WITH PHYSICAL LINE 2 (2304) *
*****
*
G31LSOC2 GROUP CASDL=0.0,          *
          DELAY=0.2,                 *
          LNCTL=CA,                  *
          MAXPU=16,                  *

```

Figure A-4 (Part 41 of 46). NCP A31 Sample Generation Definition

## NCP A31 Sample Generation Definition

```
PHYSRSC=A31P2304, *
PUDR=YES, *
SPEED=144000000, *
SRT=(20000,20000), *
TIMEOUT=840.0, *
TRANSFR=200
*
*****
*   ESCON LOGICAL LINE 1 GROUP 2 (ESCON PHYSICAL CHANNEL 2304)   *
*****
*
A31S2L1  LINE ADDRESS=NONE,          ESCON PHYSICAL CHANNEL 2304 *
          HOSTLINK=1,                LOGICAL LINE 1             *
          MONLINK=NO
*
A31S2P11 PU ADDR=01, *
          ANS=CONTINUE, *
          PUDR=NO, *
          PUTYPE=5, *
          TGN=1
*
A31S2P12 PU ADDR=02, *
          ANS=CONTINUE, *
          PUDR=NO, *
          PUTYPE=5, *
          TGN=1
*
A31S2P13 PU ADDR=03, *
          ANS=STOP, *
          PUDR=YES, *
          PUTYPE=2
*
BS2P13L1 LU LOCADDR=0
*
A31S2P14 PU ADDR=04, *
          ANS=STOP, *
          PUDR=YES, *
          PUTYPE=2
*
```

Figure A-4 (Part 42 of 46). NCP A31 Sample Generation Definition

## NCP A31 Sample Generation Definition

```
BS2P14L1 LU LOCADDR=0
*
*****
*   ESCON LOGICAL LINE 2 GROUP 2 (ESCON PHYSICAL CHANNEL 2304)   *
*****
*
A31S2L2  LINE ADDRESS=NONE,          ESCON PHYSICAL CHANNEL 2304  *
          HOSTLINK=2,                LOGICAL LINE 2             *
          MONLINK=NO
*
A31S2P21 PU ADDR=01,                *
          ANS=CONTINUE,              *
          PUDR=NO,                   *
          PUTYPE=5,                   *
          TGN=1
*
A31S2P22 PU ADDR=02,                *
          ANS=CONTINUE,              *
          PUDR=NO,                   *
          PUTYPE=5,                   *
          TGN=1
*
A31S2P23 PU ADDR=03,                *
          ANS=STOP,                  *
          PUDR=YES,                  *
          PUTYPE=2
*
BS2P23L1 LU LOCADDR=0
*
A31S2P24 PU ADDR=04,                *
          ANS=STOP,                  *
          PUDR=YES,                  *
          PUTYPE=2
*
BS2P24L1 LU LOCADDR=0
*
*****
*   ESCON LOGICAL LINE 3 GROUP 2 (ESCON PHYSICAL CHANNEL 2304)   *
*****
*
A31S2L3  LINE ADDRESS=NONE,          ESCON PHYSICAL CHANNEL 2304  *
          HOSTLINK=3,                LOGICAL LINE 3             *
          MONLINK=YES
*
```

Figure A-4 (Part 43 of 46). NCP A31 Sample Generation Definition

## NCP A31 Sample Generation Definition

```

A31S2P31 PU ADDR=01, *
          ANS=CONTINUE, *
          PUDR=NO, *
          PUTYPE=5, *
          TGN=1
*
A31S2P32 PU ADDR=02, *
          ANS=CONTINUE, *
          PUDR=NO, *
          PUTYPE=5, *
          TGN=1
*
A31S2P33 PU ADDR=03, *
          ANS=STOP, *
          PUDR=YES, *
          PUTYPE=2
*
BS2P33L1 LU LOCADDR=0
*
A31S2P34 PU ADDR=04, *
          ANS=STOP, *
          PUDR=YES, *
          PUTYPE=2
*
BS2P34L1 LU LOCADDR=0
*
*****
*   ESCON LOGICAL LINE 4 GROUP 2 (ESCON PHYSICAL CHANNEL 2304)   *
*****
*
A31S2L4  LINE ADDRESS=NONE,          ESCON PHYSICAL CHANNEL 2304 *
          HOSTLINK=4,                LOGICAL LINE 4           *
          MONLINK=YES
*
A31S2P41 PU ADDR=01, *
          ANS=CONTINUE, *
          PUDR=NO, *
          PUTYPE=5, *
          TGN=1
*
A31S2P42 PU ADDR=02, *
          ANS=CONTINUE, *
          PUDR=NO, *
          PUTYPE=5, *
          TGN=1
*

```

Figure A-4 (Part 44 of 46). NCP A31 Sample Generation Definition

## NCP A31 Sample Generation Definition

```

A31S2P43 PU ADDR=03, *
                ANS=STOP, *
                PUDR=YES, *
                PUTYPE=2
*
BS2P43L1 LU LOCADDR=0
*
A31S2P44 PU ADDR=04, *
                ANS=STOP, *
                PUDR=YES, *
                PUTYPE=2
*
BS2P44L1 LU LOCADDR=0
*
*****
*
* CHANNEL ADAPTERS - CODED CA=TYPE7 WILL TAKE ADVANTAGE OF BUFFER *
* CHAINING CHANNEL ADAPTER IF INSTALLED. IT WILL *
* ACT AS TYPE 6 IF CADS IS INSTALLED. *
*****
***
A31CAG1 GROUP CA=TYPE7, *
                ISTATUS=ACTIVE, *
                LNCTL=CA, *
                NCPA=ACTIVE, *
                NPACOLL=YES, *
                TIMEOUT=480.0, *
                TRANSFR=200
*
*****
* CA ADDR - P1 -- PHYSICAL PORT 1 -- TG=1 CONNECT TO HOST A81N *
* MOUNT TO HOST ID AS 012 - LOAD NCP OVER 012 *
*****
*
A31CP1 LINE ADDRESS=P1, *
                CASDL=420, *
                DELAY=0.2
*
A31P01A PU PUTYPE=5, *
                TGN=1
*

```

Figure A-4 (Part 45 of 46). NCP A31 Sample Generation Definition



## NCP A31 Sample Generation Definition

```
*****
* CA ADDR - P3 -- PHYSICAL PORT 3 -- TG=255 CONNECT TO HOST A81N *
* MOUNT TO HOST ID AS 013 - ACTIVATE CONNECTION *
* WITH CHANNEL DECK A81CHN *
*****
*
A31CP3 LINE ADDRESS=P3, *
        CASDL=420, *
        DELAY=0.2
*
A31P03A PU PUTYPE=5, *
        TGN=255
*****
* CA ADDR - P5 -- PHYSICAL PORT 5 -- TG=1 CONNECT TO HOST A81N *
* BACKUP CA - MOUNT TO HOST ID AS 012 - LOAD NCP OVER 012 *
*****
*
A31CP5 LINE ADDRESS=P5, *
        CASDL=420, *
        DELAY=0.2
*
A31P05A PU PUTYPE=5, *
        TGN=1
*
*****
* CA ADDR - P7 -- PHYSICAL PORT 7 -- TG=255 CONNECT TO HOST A81N *
* BACKUP CA - MOUNT TO HOST ID AS 013 - ACTIVATE CONNECTION *
* WITH CHANNEL DECK A81CHN *
*****
*
A31CP7 LINE ADDRESS=P7, *
        CASDL=420, *
        DELAY=0.2
*
A31P07A PU PUTYPE=5, *
        TGN=255
*
*
GENEND GENEND
```

Figure A-4 (Part 46 of 46). NCP A31 Sample Generation Definition

## NCP B31 Sample Generation Definition

```

*****
***** IFWB31 - NCP FOR SAMPLES NETWORK SUBAREA = 31 *****
*****
*
*          |-----|          |-----|
*          |  HOST  |          |  HOST  |
*          |  C01N  |          |  B01N  |
*          |-----|          |-----|
*
*          |          |          |          |
*          |  CA-5   |          |  CA-7   |
*          |  TGN-1  |          |  TGN-1  |
*          |          |          |          |
*          |-----|          |-----|
*
*          |          |
*          |  NCP IFWB31  |
*          |    SA=31    |
*          |          |
*          |-----|
*
*
*****
*
* LINE          FUNCTION
* ----          -
* 000          BSC DEVICES
* 003          SDLC 9.6 LEASED - PU 2.1
* 004          SDLC 9.6 LEASED - PU 2.1
* 020          SDLC 56 KB LEASED - PU 2.1
* 035          MULTIPOINT SDLC LINE - DLU'S & ILU'S
* 048          LEASED SDLC 56KB SUBAREA LINE TO A03NCP
* 052          FRAME RELAY - FULL DUPLEX 56KB
*              DLCI DIRECTLY TO A03NCP
* 1092         TOKEN-RING SUBAREA AND PERIPHERAL
*              LOGICAL TR SUBAREA TO B75NCP 1088 IN NETB
*              LOGICAL TR SUBAREA TO A03NCP 1088 IN NETC
*              IP OVER TOKEN RING CONNECTION TO A03NCP 1088
* 1093         TOKEN-RING PERIPHERAL ONLY
* 1036         FRAME RELAY - FULL DUPLEX HPTSS
*              LOGICAL CONNECTION TO A03NCP VIA A FRAME RELAY NETWORK
*              THROUGH C04NCP AND B75NCP
*              LOGICAL CONNECTION TO B75NCP VIA A FRAME RELAY NETWORK
*              THROUGH C04NCP
*

```

Figure A-5 (Part 1 of 27). NCP B31 Sample Generation Definition

## NCP B31 Sample Generation Definition

```

* 1070      ETHERNET INTERFACE
* 1071      ETHERNET INTERFACE
*           NCSTLU TO HOSTB01
*           NCSTLU TO HOSTC01
*           NCSTLU TO A03NCP
* 2144      INTERNAL IP COUPLING
*
*
*****
*           NCP OPTIONS MACRO - MISCELLANEOUS OPTIONS           *
*****
                OPTIONS NEWDEFN=(YES,ECHO)
*
*****
*           VTAM PCCU MACRO - HOSTS THAT WILL ACTIVATE THIS NCP   *
*****
*
BPCCU1  PCCU AUTOSYN=YES,                                     *
                BACKUP=YES,                                   *
                CDUMPDS=CSPDUMP,                             *
                CONFGDS=CRNCKPT,                             *
                DUMPDS=VTAMDUMP,                             *
                GWCTL=SHR,                                     *
                MAXDATA=4096,                                 *
                MDUMPDS=MOSSDUMP,                             *
                NETID=NETB,                                   *
                OWNER=B01N,                                   *
                SUBAREA=01
*
BPCCU2  PCCU AUTOSYN=YES,                                     *
                BACKUP=YES,                                   *
                CDUMPDS=CSPDUMP,                             *
                CONFGDS=CRNCKPT,                             *
                DUMPDS=VTAMDUMP,                             *
                GWCTL=SHR,                                     *
                MAXDATA=4096,                                 *
                MDUMPDS=MOSSDUMP,                             *
                NETID=NETC,                                   *
                OWNER=C01N,                                   *
                SUBAREA=01
*

```

Figure A-5 (Part 2 of 27). NCP B31 Sample Generation Definition

## NCP B31 Sample Generation Definition

```

*****
*      NCP BUILD MACRO - NCP/CONTROLLER INFO      *
*****
*
IFWB31  BUILD  ADDESS=500,                          *
          AUXADDR=500,                              *
          BFRS=128,                                  *
          BRANCH=8000,                               *
          CATRACE=(YES,255),                         *
          CNLSQMAX=10000,                            *
          CNLSQTIM=10,                               *
          CSMG=C3D9C9E340E2C9E340D4C5E2E2C1C7C540C6D6D940E2E2404*
          40C2C340E3C5D9D4C9D5C1D3,                *
          CWALL=26,                                  *
          DYNNSC=50,                                 *
          DYNNSX=50,                                 *
          DYNPOOL=(50,35),                           *
          ENABLTO=30.0,                              *
          ERLIMIT=16,                                *
          GWSESAC=(YES,NODEFER,,1000,500,,10,11,12,13,14,15), *
          HSBPOOL=6000,                              *
          IPPOOL=NCP,                                *
          IPRATE=(40,50),                            *
          LOADLIB=NCPLoad,                           *
          LTRACE=8,                                  *
          MAXSESS=250,                               *
          MAXSSCP=8,                                 *
          MODEL=3745-21A,                            *
          NAMTAB=120,                                 *
          NETID=NETB,                                 *
          NEWNAME=IFWB31,                            *
          NPA=(YES,DRTP),                            *
          NUMHSAS=8,                                  *
          OLT=YES,                                    *
          PWROFF=YES,                                 *
          SALIMIT=2047,                              *
          SESSACC=(YES,ALL,,1000,500,,10,11,12,13,14,15), *
          SLODOWN=12,                                *
          SUBAREA=31,                                 *
          TRACE=(YES,100),                           *
          TRANSFR=41,                                *
          TYPGEN=NCP,                                *
          TYP SYS=MVS,                                *
          T2TIMER=(1.9,2.0,45),                      *
          USGTIER=5,                                  *
          CSSTIER=C,                                  *
          VERSION=V7R6F,                             *
          VRPOOL=150,                                 *
          VRTIMER0=(180,,50),                         *
          VRTIMER1=(180,,50),                         *
          VRTIMER2=(180,,50),                         *
          T1TIMER=(19.0,20.0)
*

```

Figure A-5 (Part 3 of 27). NCP B31 Sample Generation Definition

## NCP B31 Sample Generation Definition

```
*****
*   DYNAMIC CONTROL FACILITIES USED BY VTAM   *
*****
*
*   SYSCNTRL OPTIONS=(BACKUP,BHSASSC,DLRID,DVSINIT,ENDCALL,LNSTAT,
*   MODE,NAKLIM,RCNTRL,RCOND,RDEVQ,RECMD,RIMM,SESINIT,SESSIO*
*   N,SSPAUSE,STORDSP,XMTLMT)
*
*****
*   NCP HOST MACRO - CHANNEL ATTACHED HOST DEFINITIONS   *
*****
*
B01N   HOST BFRPAD=0, *
        MAXBFRU=16, *
        NETID=NETB, *
        SUBAREA=01, *
        UNITSZ=256
*
C01N   HOST BFRPAD=0, *
        MAXBFRU=16, *
        NETID=NETC, *
        SUBAREA=01, *
        UNITSZ=256
*
*****
*   NATIVE NETWORK DEFINITIONS   *
*****
*
*   GWNAU NETID=NETA,NAME=A01N,NUMSESS=5,ELEMENT=1
*   GWNAU NETID=NETA,NAME=A02N,NUMSESS=5,ELEMENT=2
*   GWNAU NETID=NETA,NAME=A17N,NUMSESS=5,ELEMENT=3
*   GWNAU NETID=NETA,NAME=A81N,NUMSESS=5,ELEMENT=4
*   GWNAU NETID=NETC,NAME=C01N,NUMSESS=5,ELEMENT=6
*
*   GWNAU NUMADDR=600
*
```

Figure A-5 (Part 4 of 27). NCP B31 Sample Generation Definition

## NCP B31 Sample Generation Definition

```
*****
*   PATH DECK FOR NATIVE NETWORK   *
*****
    PATH DESTSA=1, *
      ER0=(3,1),ER2=(3,1),ER4=(3,1),ER6=(3,1), *
      ER1=(1,1),ER3=(1,1),ER5=(1,1),ER7=(1,1), *
      VR0=0, *
      VRPWS00=(1,3),VRPWS01=(1,3),VRPWS02=(1,3), *
      VR1=1, *
      VRPWS10=(2,6),VRPWS11=(2,6),VRPWS12=(2,6), *
      VR2=2, *
      VRPWS20=(2,6),VRPWS21=(2,6),VRPWS22=(2,6), *
      VR3=3, *
      VRPWS30=(2,6),VRPWS31=(2,6),VRPWS32=(2,6), *
      VR4=4, *
      VRPWS40=(3,9),VRPWS41=(3,9),VRPWS42=(3,9), *
      VR5=5, *
      VRPWS50=(3,9),VRPWS51=(3,9),VRPWS52=(3,9), *
      VR6=6, *
      VRPWS60=(3,9),VRPWS61=(3,9),VRPWS62=(3,9), *
      VR7=7, *
      VRPWS70=(3,9),VRPWS71=(3,9),VRPWS72=(3,9)
*
    PATH DESTSA=3, *
      ER0=(1,1),ER2=(1,1),ER4=(1,1),ER6=(1,1), *
      ER1=(3,1),ER3=(3,1),ER5=(3,1),ER7=(3,1), *
      VR0=0, *
      VRPWS00=(1,3),VRPWS01=(1,3),VRPWS02=(1,3), *
      VR1=1, *
      VRPWS10=(2,6),VRPWS11=(2,6),VRPWS12=(2,6), *
      VR2=2, *
      VRPWS20=(2,6),VRPWS21=(2,6),VRPWS22=(2,6), *
      VR3=3, *
      VRPWS30=(2,6),VRPWS31=(2,6),VRPWS32=(2,6), *
      VR4=4, *
      VRPWS40=(3,9),VRPWS41=(3,9),VRPWS42=(3,9), *
      VR5=5, *
      VRPWS50=(3,9),VRPWS51=(3,9),VRPWS52=(3,9), *
      VR6=6, *
      VRPWS60=(3,9),VRPWS61=(3,9),VRPWS62=(3,9), *
      VR7=7, *
      VRPWS70=(3,9),VRPWS71=(3,9),VRPWS72=(3,9)
*
```

Figure A-5 (Part 5 of 27). NCP B31 Sample Generation Definition

## NCP B31 Sample Generation Definition

```
PATH DESTSA=(75,1028),
ER0=(75,1),ER1=(75,1),ER2=(75,1),
ER3=(75,1),ER4=(75,1),ER5=(75,1),
ER6=(75,1),ER7=(75,1),
VR0=0,
VRPWS00=(1,3),VRPWS01=(1,3),VRPWS02=(1,3),
VR1=1,
VRPWS10=(2,6),VRPWS11=(2,6),VRPWS12=(2,6),
VR2=2,
VRPWS20=(2,6),VRPWS21=(2,6),VRPWS22=(2,6),
VR3=3,
VRPWS30=(2,6),VRPWS31=(2,6),VRPWS32=(2,6),
VR4=4,
VRPWS40=(3,9),VRPWS41=(3,9),VRPWS42=(3,9),
VR5=5,
VRPWS50=(3,9),VRPWS51=(3,9),VRPWS52=(3,9),
VR6=6,
VRPWS60=(3,9),VRPWS61=(3,9),VRPWS62=(3,9),
VR7=7,
VRPWS70=(3,9),VRPWS71=(3,9),VRPWS72=(3,9)
*****
*   NCP SDLCST MACRO - SDLC SUBAREA COMMUNICATION CONTROLLER LINKS   *
*****
*
*
S31PRI   SDLCST GROUP=B31GPRI,
          MODE=PRI
*
S31SEC   SDLCST GROUP=B31GSEC,
          MODE=SEC
*
*****
*   NCP POOL MACROS - NECESSARY FOR DYN RECONFIG & SWITCHED SDLC LINKS *
*****
*
          PUDRPOOL NUMBER=10
*
          LUDRPOOL NUMILU=500,
          NUMTYP1=05,
          NUMTYP2=500
*
```

Figure A-5 (Part 6 of 27). NCP B31 Sample Generation Definition

## NCP B31 Sample Generation Definition

```
*****
*      BSC GROUP DEFINITION      *
*****
*
B31BNNB0 GROUP AVGPB=125,          *
      CLOCKNG=EXT,                 *
      CODE=EBCDIC,                 *
      CONV=YES,                    *
      CRETRY=7,                    *
      CRITSIT=NO,                  *
      DIAL=NO,                     *
      DIRECTN=INOUT,               *
      DLOGMOD=MBSCQ,               *
      DUPLEX=FULL,                 *
      FEATURE=GPLKUP,              *
      ISTATUS=INACTIVE,            *
      LNCTL=BSC,                   *
      MODETAB=AMODETAB,            *
      NEGPOLP=.2,                  *
      NPACOLL=YES,                 *
      PAUSE=0,                      *
      POLIMIT=(10,QUEUE),          *
      POLLED=YES,                   *
      REPLYTO=3,                    *
      RETRIES=(5,5,5),             *
      SERVLIM=15,                  *
      SERVPRI=OLD,                  *
      SESSION=32,                  *
      TRANSFR=8,                   *
      USSTAB=AUSSTAB
*
*
```

Figure A-5 (Part 7 of 27). NCP B31 Sample Generation Definition



## NCP B31 Sample Generation Definition

```
*****
*   ADDRESS 000                               : BSC LEASED LINE   *
*****
*
B31B00  LINE ADDRESS=000
*
B31C001 CLUSTER CUTYPE=3271,GPOLL=40407F7F,LOGTAB=INTERP
*
B31T0011 TERMINAL TERM=3277,ADDR=60604040,POLL=40404040
B31T0012 TERMINAL TERM=3277,ADDR=6060C1C1,POLL=4040C1C1
B31T0013 TERMINAL TERM=3277,ADDR=6060C2C2,POLL=4040C2C2
B31T0014 TERMINAL TERM=3277,ADDR=6060C3C3,POLL=4040C3C3
B31T0015 TERMINAL TERM=3277,ADDR=6060C4C4,POLL=4040C4C4
B31T0016 TERMINAL TERM=3277,ADDR=6060C5C5,POLL=4040C5C5
B31T0017 TERMINAL TERM=3277,ADDR=6060C6C6,POLL=4040C6C6
B31T0018 TERMINAL TERM=3277,ADDR=6060C7C7,POLL=4040C7C7
B31T0019 TERMINAL TERM=3277,ADDR=6060C8C8,POLL=4040C8C8
B31T001A TERMINAL TERM=3277,ADDR=6060C9C9,POLL=4040C9C9
B31T001B TERMINAL TERM=3277,ADDR=60604A4A,POLL=40404A4A
B31T001C TERMINAL TERM=3277,ADDR=60604B4B,POLL=40404B4B
B31T001D TERMINAL TERM=3277,ADDR=60604C4C,POLL=40404C4C
B31T001E TERMINAL TERM=3277,ADDR=60604D4D,POLL=40404D4D
B31T001F TERMINAL TERM=3277,ADDR=60604E4E,POLL=40404E4E
*
B31C002 CLUSTER CUTYPE=3271,GPOLL=C1C17F7F,LOGTAB=INTERP
*
B31T0021 TERMINAL TERM=3277,ADDR=61614040,POLL=C1C14040
B31T0022 TERMINAL TERM=3277,ADDR=6161C1C1,POLL=C1C1C1C1
B31T0023 TERMINAL TERM=3277,ADDR=6161C2C2,POLL=C1C1C2C2
B31T0024 TERMINAL TERM=3277,ADDR=6161C3C3,POLL=C1C1C3C3
B31T0025 TERMINAL TERM=3277,ADDR=6161C4C4,POLL=C1C1C4C4
B31T0026 TERMINAL TERM=3277,ADDR=6161C5C5,POLL=C1C1C5C5
B31T0027 TERMINAL TERM=3277,ADDR=6161C6C6,POLL=C1C1C6C6
B31T0028 TERMINAL TERM=3277,ADDR=6161C7C7,POLL=C1C1C7C7
B31T0029 TERMINAL TERM=3277,ADDR=6161C8C8,POLL=C1C1C8C8
B31T002A TERMINAL TERM=3277,ADDR=6161C9C9,POLL=C1C1C9C9
B31T002B TERMINAL TERM=3277,ADDR=61614A4A,POLL=C1C14A4A
B31T002C TERMINAL TERM=3277,ADDR=61614B4B,POLL=C1C14B4B
B31T002D TERMINAL TERM=3277,ADDR=61614C4C,POLL=C1C14C4C
B31T002E TERMINAL TERM=3277,ADDR=61614D4D,POLL=C1C14D4D
B31T002F TERMINAL TERM=3277,ADDR=61614E4E,POLL=C1C14E4E
*
```

Figure A-5 (Part 8 of 27). NCP B31 Sample Generation Definition

## NCP B31 Sample Generation Definition

```
*****
*   ADDRESS 032                               : BSC LEASED LINE   *
*****
*
B31B32  LINE ADDRESS=032
*
B31C321 CLUSTER CUTYPE=3271,GPOLL=40407F7F,LOGTAB=INTERP
*
B31T3211 TERMINAL TERM=3277,ADDR=60604040,POLL=40404040
B31T3212 TERMINAL TERM=3277,ADDR=6060C1C1,POLL=4040C1C1
B31T3213 TERMINAL TERM=3277,ADDR=6060C2C2,POLL=4040C2C2
B31T3214 TERMINAL TERM=3277,ADDR=6060C3C3,POLL=4040C3C3
B31T3215 TERMINAL TERM=3277,ADDR=6060C4C4,POLL=4040C4C4
B31T3216 TERMINAL TERM=3277,ADDR=6060C5C5,POLL=4040C5C5
B31T3217 TERMINAL TERM=3277,ADDR=6060C6C6,POLL=4040C6C6
B31T3218 TERMINAL TERM=3277,ADDR=6060C7C7,POLL=4040C7C7
B31T3219 TERMINAL TERM=3277,ADDR=6060C8C8,POLL=4040C8C8
B31T321A TERMINAL TERM=3277,ADDR=6060C9C9,POLL=4040C9C9
B31T321B TERMINAL TERM=3277,ADDR=60604A4A,POLL=40404A4A
B31T321C TERMINAL TERM=3277,ADDR=60604B4B,POLL=40404B4B
B31T321D TERMINAL TERM=3277,ADDR=60604C4C,POLL=40404C4C
B31T321E TERMINAL TERM=3277,ADDR=60604D4D,POLL=40404D4D
B31T321F TERMINAL TERM=3277,ADDR=60604E4E,POLL=40404E4E
*
B31C322 CLUSTER CUTYPE=3271,GPOLL=C1C17F7F,LOGTAB=INTERP
*
B31T3221 TERMINAL TERM=3277,ADDR=61614040,POLL=C1C14040
B31T3222 TERMINAL TERM=3277,ADDR=6161C1C1,POLL=C1C1C1C1
B31T3223 TERMINAL TERM=3277,ADDR=6161C2C2,POLL=C1C1C2C2
B31T3224 TERMINAL TERM=3277,ADDR=6161C3C3,POLL=C1C1C3C3
B31T3225 TERMINAL TERM=3277,ADDR=6161C4C4,POLL=C1C1C4C4
B31T3226 TERMINAL TERM=3277,ADDR=6161C5C5,POLL=C1C1C5C5
B31T3227 TERMINAL TERM=3277,ADDR=6161C6C6,POLL=C1C1C6C6
B31T3228 TERMINAL TERM=3277,ADDR=6161C7C7,POLL=C1C1C7C7
B31T3229 TERMINAL TERM=3277,ADDR=6161C8C8,POLL=C1C1C8C8
B31T322A TERMINAL TERM=3277,ADDR=6161C9C9,POLL=C1C1C9C9
B31T322B TERMINAL TERM=3277,ADDR=61614A4A,POLL=C1C14A4A
B31T322C TERMINAL TERM=3277,ADDR=61614B4B,POLL=C1C14B4B
B31T322D TERMINAL TERM=3277,ADDR=61614C4C,POLL=C1C14C4C
B31T322E TERMINAL TERM=3277,ADDR=61614D4D,POLL=C1C14D4D
B31T322F TERMINAL TERM=3277,ADDR=61614E4E,POLL=C1C14E4E
*
*****
*   NPA DEFINITION - NETWORK PERFORMANCE ANALYZER   *
*****
*
B31NPAG GROUP LNCTL=SDLC,                       *
          NPARSC=YES,                           *
          VIRTUAL=YES                             *
*
B31NPAL LINE
*
```

Figure A-5 (Part 9 of 27). NCP B31 Sample Generation Definition

## NCP B31 Sample Generation Definition

```

B31NPAP  PU
*
B31NPLU1 LU
B31NPLU2 LU
B31NPLU3 LU
B31NPLU4 LU
B31NPLU5 LU
B31NPLU6 LU
B31NPLU7 LU
B31NPLU8 LU
*
*****
*   GROUP FOR LEASED PERIPHERAL LINES   *
*****
*
B31LBNS GROUP ANS=CONT,          *
                AVGPB=125,        *
                DIAL=NO,          *
                DUPLEX=FULL,      *
                IRETRY=YES,       *
                ISTATUS=INACTIVE, *
                LNCTL=SDLC,       *
                MAXDATA=265,     *
                MAXOUT=7,        *
                MODETAB=AMODETAB, *
                NRZI=YES,        *
                NPACOLL=YES,     *
                PACING=0,        *
                PASSLIM=7,       *
                PUTYPE=2,        *
                REPLYTO=3,       *
                RETRIES=(,3,5),  *
                SERVLIM=10,      *
                TYPE=NCP,        *
                USSTAB=AUSSTAB   *
*
*****
*   ADDRESSES 03 & 04 1 PU ( DR CAPABLE ), 5 DLU, 5 ILU EACH   *
*****
*
B31S03  LINE ADDRESS=(003,FULL), *
                CLOCKNG=EXT,     *
                DUPLEX=FULL,     *
                ISTATUS=ACTIVE,  *
                MAXPU=25,        *
                MODETAB=AMODETAB, *
                NRZI=YES,        *
                PACING=7,        *
                PUDR=YES,        *
                RETRIES=(5,5,5), *
                SPEED=9600       *
                SERVICE MAXLIST=25
*

```

Figure A-5 (Part 10 of 27). NCP B31 Sample Generation Definition

## NCP B31 Sample Generation Definition

```
B31P03A  PU ADDR=C1, *
          XID=YES
*
B31D031A LU LOCADDR=01
B31D031B LU LOCADDR=02
B31D031C LU LOCADDR=03
B31D031D LU LOCADDR=04
B31D031E LU LOCADDR=05
*
B31I031A LU LOCADDR=0,RESSCB=5
B31I031B LU LOCADDR=0,RESSCB=5
B31I031C LU LOCADDR=0,RESSCB=5
B31I031D LU LOCADDR=0,RESSCB=5
B31I031E LU LOCADDR=0,RESSCB=5
*
B31S04   LINE ADDRESS=(004,FULL), *
          CLOCKNG=EXT, *
          DUPLEX=FULL, *
          ISTATUS=ACTIVE, *
          MAXPU=25, *
          MODETAB=AMODETAB, *
          NRZI=YES, *
          PACING=7, *
          PUDR=YES, *
          RETRIES=(5,5,5), *
          SPEED=9600
          SERVICE MAXLIST=25
*
B31P04A  PU ADDR=C1, *
          XID=YES
B31D041A LU LOCADDR=01
B31D041B LU LOCADDR=02
B31D041C LU LOCADDR=03
B31D041D LU LOCADDR=04
B31D041E LU LOCADDR=05
*
B31I041A LU LOCADDR=0,RESSCB=5
B31I041B LU LOCADDR=0,RESSCB=5
B31I041C LU LOCADDR=0,RESSCB=5
B31I041D LU LOCADDR=0,RESSCB=5
B31I041E LU LOCADDR=0,RESSCB=5
*
*
```

Figure A-5 (Part 11 of 27). NCP B31 Sample Generation Definition

## NCP B31 Sample Generation Definition

```

*****
*   ADDRESS 35 1 PU ( DR CAPABLE ), 5 DLU, 5 ILU   *
*****
*
B31S35  LINE ADDRESS=(035,FULL),                    *
          CLOCKNG=EXT,                               *
          DUPLEX=FULL,                               *
          ISTATUS=ACTIVE,                           *
          MAXPU=25,                                  *
          MODETAB=AMODETAB,                          *
          NRZI=YES,                                  *
          PACING=7,                                  *
          PUDR=YES,                                  *
          RETRIES=(5,5,5),                           *
          SPEED=9600                                  *
          SERVICE MAXLIST=25
*
B31P35A  PU ADDR=C1,                                *
          XID=YES
*
B31D351A LU DLOGMOD=M23278I,                          *
          LOCADDR=01
B31D351B LU DLOGMOD=M23278I,                          *
          LOCADDR=02
B31D351C LU DLOGMOD=M3767,                            *
          LOCADDR=03
B31D351D LU DLOGMOD=M3767,                            *
          LOCADDR=04
B31D351E LU LOCADDR=05
*
B31I351A LU LOCADDR=0,                                *
          DLOGMOD=PARALLEL,                          *
          RESSCB=5
B31I351B LU LOCADDR=0,                                *
          DLOGMOD=PARALLEL,                          *
          RESSCB=5
B31I351C LU LOCADDR=0,                                *
          DLOGMOD=PARALLEL,                          *
          RESSCB=5
B31I351D LU LOCADDR=0,                                *
          DLOGMOD=PARALLEL,                          *
          RESSCB=5
B31I351E LU LOCADDR=0,                                *
          DLOGMOD=PARALLEL,                          *
          RESSCB=5
*

```

Figure A-5 (Part 12 of 27). NCP B31 Sample Generation Definition

## NCP B31 Sample Generation Definition

```

B31P35B PU ADDR=C2, *
        XID=YES
*
B31D352A LU DLOGMOD=M23278I, *
        LOCADDR=01
B31D352B LU DLOGMOD=M23278I, *
        LOCADDR=02
B31D352C LU DLOGMOD=M3767, *
        LOCADDR=03
B31D352D LU DLOGMOD=M3767, *
        LOCADDR=04
B31D352E LU LOCADDR=05
*
B31I352A LU LOCADDR=0, *
        DLOGMOD=PARALLEL, *
        RESSCB=5
B31I352B LU LOCADDR=0, *
        DLOGMOD=PARALLEL, *
        RESSCB=5
B31I352C LU LOCADDR=0, *
        DLOGMOD=PARALLEL, *
        RESSCB=5
B31I352D LU LOCADDR=0, *
        DLOGMOD=PARALLEL, *
        RESSCB=5
B31I352E LU LOCADDR=0, *
        DLOGMOD=PARALLEL, *
        RESSCB=5
*
*****
*   ADDRESSES 20      1 PU ( DR CAPABLE ), 10 DLU, 2 ILU EACH *
*****
*
B31S20  LINE ADDRESS=(020,FULL), *
        CLOCKNG=EXT, *
        DUPLEX=FULL, *
        ISTATUS=ACTIVE, *
        MAXPU=25, *
        MODETAB=AMODETAB, *
        NRZI=YES, *
        PACING=7, *
        RETRIES=(5,5,5), *
        SPEED=56000
        SERVICE MAXLIST=25
*

```

Figure A-5 (Part 13 of 27). NCP B31 Sample Generation Definition

## NCP B31 Sample Generation Definition

```

B31P20A  PU ADDR=C1,                                     *
          XID=YES
*
B31D201A LU LOCADDR=01
*
B31P20B  PU ADDR=C2,                                     *
          ANS=CONT,                                     *
          IRETRY=YES,                                  *
          ISTATUS=INACTIVE,                            *
          LOGTAB=INTERP,                               *
          MAXDATA=256,                                 *
          MAXOUT=7,                                    *
          MODETAB=AMODETAB,                            *
          PASSLIM=8,                                   *
          PUDR=YES,                                    *
          PUTYPE=2,                                    *
          USSTAB=AUSSTAB,                              *
          XID=YES
*
B31D202A LU LOCADDR=1
B31D202B LU LOCADDR=2
B31D202C LU LOCADDR=3
B31D202D LU LOCADDR=4
B31D202E LU LOCADDR=5
B31D202F LU LOCADDR=6
B31D202G LU LOCADDR=7
B31D202H LU LOCADDR=8
B31D202I LU LOCADDR=9
B31D202J LU LOCADDR=10
B31I202A LU LOCADDR=0,RESSCB=5
B31I202B LU LOCADDR=0,RESSCB=5
*
B31P20C  PU ADDR=C3,                                     *
          ANS=CONT,                                     *
          IRETRY=YES,                                  *
          ISTATUS=INACTIVE,                            *
          LOGTAB=INTERP,                               *
          MAXDATA=256,                                 *
          MAXOUT=7,                                    *
          MODETAB=AMODETAB,                            *
          PASSLIM=8,                                   *
          PUDR=YES,                                    *
          PUTYPE=2,                                    *
          USSTAB=AUSSTAB,                              *
          XID=YES
*

```

Figure A-5 (Part 14 of 27). NCP B31 Sample Generation Definition

## NCP B31 Sample Generation Definition

```
B31D203A LU LOCADDR=1
B31D203B LU LOCADDR=2
B31D203C LU LOCADDR=3
B31D203D LU LOCADDR=4
B31D203E LU LOCADDR=5
B31D203F LU LOCADDR=6
B31D203G LU LOCADDR=7
B31D203H LU LOCADDR=8
B31D203I LU LOCADDR=9
B31D203J LU LOCADDR=10
B31I203A LU LOCADDR=0,RESSCB=5
B31I203B LU LOCADDR=0,RESSCB=5
*
*****
* SUBAREA LINK: SDLC FOR PRIMARY/SECONDARY STATION *
*****
*
B31GPRI GROUP ACTIVTO=60.0, *
          DIAL=NO, *
          LNCTL=SDLC, *
          MODE=PRI, *
          REPLYTO=30, *
          TYPE=NCP
*
B31GSEC GROUP ACTIVTO=60.0, *
          DIAL=NO, *
          LNCTL=SDLC, *
          MODE=SEC, *
          TYPE=NCP
*
*****
* ADDRESS 048 LEASED 56KB LINE TO A03NCP *
*****
*
B31LEAS1 GROUP ACTIVTO=60.0, *
            DIAL=NO, *
            LNCTL=SDLC, *
            MODULO=128, *
            NETID=NETB, *
            REPLYTO=3, *
            TYPE=NCP
*
```

Figure A-5 (Part 15 of 27). NCP B31 Sample Generation Definition



## NCP B31 Sample Generation Definition

```

*****
* SUBAREA LINE ADDRESS=48 FULL DUPLEX 56KB Q *
* NETID = (NETB) TO A03NCP *
*****
*
B31S48 LINE ADDRESS=(048,FULL), *
        CLOCKNG=EXT, *
        DUPLEX=FULL, *
        IPL=NO, *
        ISTATUS=INACTIVE, *
        MONLINK=YES, *
        NEWSYNC=NO, *
        NRZI=YES, *
        RETRIES=(5,5,5), *
        SDLCST=(S31PRI,S31SEC), *
        SPEED=56000, *
        TRANSFR=41
B31P48 PU AVGPB=256, *
        IRETRY=YES, *
        MAXOUT=127, *
        MODULO=128, *
        PUTYPE=4, *
        TGN=1
*
*****
* NCP TOKEN-RING INTERCONNECT PHYSICAL LINES *
*****
*
B31INTR1 GROUP ADAPTER=TIC2, *
               ANS=CONTINUE, *
               ECLTYPE=(PHYSICAL,ANY), *
               MAXTSL=4060, *
               RCVBUFC=32000, *
               RETRIES=(20,5,5), *
               USSTAB=AUSSTAB, *
               XID=NO, *
               TYPE=NCP, *
               DIAL=NO, *
               LNCTL=SDLC, *
               LEVEL2=ECLNARL2, *
               LEVEL3=ECLNARL3, *
               LEVEL5=NCP, *
               TIMER=(ECLNART1,,ECLNART2,ECLNART3), *
               XIO=(ECLNARXL,ECLNARXS,ECLNARXI,ECLNARXK), *
               USERID=(5668854,ECLRBDT,NORECMS,,ECLNMVT), *
               SPEED=9600, *
               NPACOLL=NO, *
               PUTYPE=1, *
               PUDR=NO, *
               COMPTAD=YES, *
               COMPSWP=YES, *
               COMPOWN=YES
*

```

Figure A-5 (Part 16 of 27). NCP B31 Sample Generation Definition

## NCP B31 Sample Generation Definition

```
*****
*   ADDRESS 1092:  NTRI PHYSICAL LINE   *
*****
B31TR92  LINE ADDRESS=(1092,FULL),      *
          INTFACE=TR92,                 *
          LOCADD=400000017335,          *
          PORTADD=5,                    *
          TRSPEED=4,                   *
          UACB=(X$P1AX,X$P1AR)
*
*   PU FOR SNA TRAFFIC
*
B31PU92  PU ADDR=01,                    *
          NETWORK=SNA,                  *
          PUTYPE=1,                     *
          INNPORT=YES
*
*   PU FOR IP TRAFFIC
*
B31PU92A PU ADDR=02,                    *
          ARPTAB=(1000,20,NOTCANON),    *
          NETWORK=IP,                   *
          PUTYPE=1,                     *
          INNPORT=YES
*
*****
*   ADDRESS 1093:  NTRI PHYSICAL LINE   *
*****
B31NTR2  GROUP ANS=CONTINUE,            *
          ECLTYPE=(PHYSICAL,PER),       *
          RETRIES=(20,5,5),             *
          USSTAB=AUSSTAB,               *
          XID=NO,                       *
          TYPE=NCP,                     *
          DIAL=NO,                      *
          LNCTL=SDLC,                   *
          LEVEL2=ECLNARL2,              *
          LEVEL3=ECLNARL3,              *
          LEVEL5=NCP,                   *
          TIMER=(ECLNART1,,ECLNART2,ECLNART3),
          XIO=(ECLNARXL,ECLNARXS,ECLNARXI,ECLNARXK),
          USERID=(5668854,ECLRBDT,NORECMS,,ECLNMVT),
          SPEED=9600,                   *
          NPACOLL=NO,                   *
          PUTYPE=1,                     *
          PUDR=NO,                      *
          COMPTAD=YES,                  *
          COMPSWP=YES,                  *
          COMPOWN=YES
*

```

Figure A-5 (Part 17 of 27). NCP B31 Sample Generation Definition

## NCP B31 Sample Generation Definition

```

*
B31TR93  LINE ADDRESS=(1093,FULL),
          ADAPTER=TIC2,
          LOCADD=400000FEDCBA,
          PORTADD=6,
          TRSPEED=4,
          UACB=(X$P2AX,X$P2AR)
*
*
B31PU93  PU ADDR=01
*
*****
*      NTRI PERIPHERAL LOGICAL LINES      *
*****
*
B31BNG1  GROUP ANS=CONTINUE,
          AUTOGEN=25,
          CALL=INOUT,
          ECLTYPE=LOGICAL,
          MODETAB=AMODETAB,
          NPACOLL=(YES,EXTENDED),
          PHYPORT=NONE,
          PHYRSC=NONE,
          RETRIES=(10,4,10,6),
          RNRLMT=3,
          USSTAB=AUSSTAB,
          XMITDLY=NONE,
          TYPE=NCP,
          DIAL=YES,
          LNCTL=SDLC,
          LEVEL2=ECLNAVL2,
          LEVEL3=ECLNAVL3,
          LEVEL5=NCP,
          XIO=(ECLNAVXL,ECLNAVXS,ECLNAVXI,ECLNAVXK),
          USERID=(5668854,ECLVBDT,NORECMS,,ECLNMVT),
          LINEADD=NONE,
          LINEAUT=YES,
          PUTYPE=2,
          COMPOWN=YES
*

```

Figure A-5 (Part 18 of 27). NCP B31 Sample Generation Definition

## NCP B31 Sample Generation Definition

```

*****
*      NTRI SUBAREA LOGICAL CONNECTIONS FOR 1092      *
*****
*
B31INNG1 GROUP ANS=CONTINUE,                               *
                ECLTYPE=(LOGICAL,SUBAREA),                 *
                MODETAB=AMODETAB,                         *
                PHYSPORT=5,                               *
                PHYSRSC=B31PU92,                          *
                SDLCST=(S31PRI,S31SEC),                   *
                TGCONF=MULTI,                             *
                USSTAB=AUSSTAB,                           *
                TYPE=NCP,                                 *
                DIAL=NO,                                  *
                LNCTL=SDLC,                               *
                LEVEL2=ECLNAVL2,                          *
                LEVEL3=ECLNAVL3,                          *
                LEVEL5=NCP,                               *
                XIO=(ECLNAVXL,ECLNAVXS,ECLNAVXI,ECLNAVXK), *
                USERID=(5668854,ECLVBDT,NORECMS,,ECLNMVT), *
                LINEADD=NONE,                             *
                NPACOLL=NO,                               *
                PUTYPE=4,                                 *
                COMPOWN=YES,                              *
                RETRIES=(6,0,0,6)
*
*****
*      NTRI SUBAREA LOGICAL LINE 1 TO A03NCP IN NETC    *
*****
*
B31LG1A  LINE TGN=1,                                       *
                UACB=X$L26A
*
B31PG1A  PU ADDR=0440000000331,NETID=NETC
*
*****
*      NTRI SUBAREA LOGICAL LINE 2 TO B75NCP IN NETB    *
*****
*
B31LG2A  LINE TGN=1,                                       *
                UACB=X$L27A
*
B31PG2A  PU ADDR=04400000007531
*

```

Figure A-5 (Part 19 of 27). NCP B31 Sample Generation Definition

## NCP B31 Sample Generation Definition

```
*****
* FRAME RELAY PHYSICAL LINE 052 - FULL DUPLEX 56KB *
*****
*
B31FRGP2 GROUP FRELAY=PHYSICAL, *
                ISTATUS=ACTIVE, *
                MAXFRAME=2106, *
                TYPE=NCP, *
                XMONLNK=YES, *
                DIAL=NO, *
                LNCTL=SDLC, *
                NPACOLL=(YES,EXTENDED), *
                PUTYPE=1
*
B31F52  LINE ADDRESS=(052,FULL), *
                CLOCKNG=EXT, *
                NRZI=NO, *
                ARPTAB=(40,,NOTCANON), *
                SPEED=56000
*
B31P52  PU ANS=CONTINUE, *
                PUDR=NO, *
                NPACOLL=(YES,EXTENDED), *
                INNPORT=YES
*
FRIPPU52 PU  PUTYPE=1, *
                ADDR=3A, *
                P2PDEST=128.10.03.99, *
                PROTOCOL=RIP, *
                METRIC=1, *
                INTFACE=(,500), *
                LADDR=128.10.31.99
*
```

Figure A-5 (Part 20 of 27). NCP B31 Sample Generation Definition

## NCP B31 Sample Generation Definition

```

*****
* FRAME RELAY LOGICAL SUBAREA LINES FOR B31F52
*****
*
B31FRGL2 GROUP FRELAY=LOGICAL,
                ISTATUS=ACTIVE,
                MAXOUT=127,
                MODULO=128,
                PHYSRSC=B31P52,
                RETRIES=(5,5,5),
                SDLCST=(S31PRI,S31SEC),
                TYPE=NCP,
                DIAL=NO,
                LNCTL=SDLC,
                LEVEL2=ECLNAVL2,
                LEVEL3=ECLNAVL3,
                LEVEL5=NCP,
                XIO=(ECLNAVXL,ECLNAVXS,ECLNAVXI,ECLNAVXK),
                LINEADD=NONE,
                NPACOLL=(YES,EXTENDED),
                PUTYPE=4,
                COMPSWP=NO,
                COMPOWN=YES
*
*****
* LOGICAL LINE 1 --- DLCI X'36' TALKS TO DLCI X'36' IN NCP A03NCP
*****
*
B31LL1G LINE ISTATUS=ACTIVE,MONLINK=YES,IPL=YES,
                UACB=X$L1B
*
B31PL1G PU ANS=CONTINUE,
                PUTYPE=4,
                TGN=1,
                DLCI=(54,D),
                NPACOLL=NO
*
*****
* FRAME RELAY PHYSICAL LINE 1036 - FULL DUPLEX HPTSS
*****
B31FRGP1 GROUP FRELAY=PHYSICAL,
                ISTATUS=ACTIVE,
                MAXFRAME=2106,
                TYPE=NCP,
                XMONLNK=YES,
                DIAL=NO,
                LNCTL=SDLC,
                NPACOLL=(YES,EXTENDED),
                PUTYPE=1
*

```

Figure A-5 (Part 21 of 27). NCP B31 Sample Generation Definition

## NCP B31 Sample Generation Definition

```

B31F1036 LINE ADDRESS=(1036,FULL),
                CLOCKNG=EXT,
                NRZI=NO,
                SPEED=1544000
*
B31P1036 PU ANS=CONTINUE,
                ERRORT=(3,4),
                LMI=CCITT,
                SPOLL=6,
                TIMERS=(10,15),
                PUDR=NO,
                NPACOLL=(YES,EXTENDED),
                INNPORT=YES
*
*****
* FRAME RELAY LOGICAL SUBAREA LINES FOR B31F1036
*****
*
B31FRGL1 GROUP FRELAY=LOGICAL,
                ISTATUS=ACTIVE,
                MAXOUT=127,
                MODULO=128,
                PHYSRSC=B31P1036,
                RETRIES=(5,5,5),
                SDLCST=(S31PRI,S31SEC),
                TYPE=NCP,
                DIAL=NO,
                LNCTL=SDLC,
                LEVEL2=ECLNAVL2,
                LEVEL3=ECLNAVL3,
                LEVEL5=NCP,
                XIO=(ECLNAVXL,ECLNAVXS,ECLNAVXI,ECLNAVXK),
                LINEADD=NONE,
                NPACOLL=(YES,EXTENDED),
                PUTYPE=4,
                COMPSWP=NO,
                COMPOWN=YES
*
*****
* LOGICAL LINE 1 --- DLCI X'1F' TALKS TO DLCI X'1E' IN NCP A03NCP
*****
*
B31LL1A LINE ISTATUS=ACTIVE,MONLINK=YES,IPL=YES,
                UACB=X$L2B
*
B31PL1A PU ANS=CONTINUE,
                PUTYPE=4,
                TGN=1,
                DLCI=(31,D),
                NPACOLL=NO
*

```

Figure A-5 (Part 22 of 27). NCP B31 Sample Generation Definition

## NCP B31 Sample Generation Definition

```
*****
* LOGICAL LINE 2 --- DLCI X'2F' TALKS TO DLCI X'2E' IN NCP A03NCP *
*****
B31LL1B LINE ISTATUS=ACTIVE,MONLINK=YES,IPL=YES, *
          UACB=X$L3B
*
B31PL1B PU ANS=CONTINUE, *
          PUTYPE=4, *
          TGN=1, *
          DLCI=(47,D), *
          NPACOLL=NO
*
*****
* LOGICAL LINE 3 --- DLCI X'3F' TALKS TO DLCI X'3E' IN NCP A03NCP *
*****
*
B31LL1C LINE ISTATUS=ACTIVE,MONLINK=YES,IPL=YES, *
          UACB=X$L4B
*
B31PL1C PU ANS=CONTINUE, *
          PUTYPE=4, *
          TGN=1, *
          DLCI=(63,D), *
          NPACOLL=NO
*
*****
* LOGICAL LINE 4 --- DLCI X'50' TALKS TO DLCI X'60' IN NCP B75NCP *
*****
*
B31LL1D LINE ISTATUS=ACTIVE,MONLINK=YES,IPL=YES, *
          UACB=X$L5B
*
B31PL1D PU ANS=CONTINUE, *
          PUTYPE=4, *
          TGN=1, *
          DLCI=(80,D), *
          NPACOLL=NO
*
*****
*   ETHERNET ADAPTER INTERFACES *
*****
*
B31ETHG GROUP DIAL=NO, *
          ETHERNET=PHYSICAL, *
          ISTATUS=ACTIVE, *
          LNCTL=SDLC, *
          VIRTUAL=NO
*
```

Figure A-5 (Part 23 of 27). NCP B31 Sample Generation Definition



## NCP B31 Sample Generation Definition

```

*****
*
B31E170  LINE ADDRESS=(1070,FULL),
          FRAMECNT=(100000,5000),
          INTERFACE=ETH1,
          LANTYPE=DYNAMIC,
          ANS=CONT
*
*
B31P170  PU ANS=CONT,
          ARPTAB=(2000,20),
          INNPOR=YES,
          PUTYPE=1,
          NPACOLL=NO,
          LPDA=BLOCK
*
*****
*
B31E171  LINE ADDRESS=(1071,FULL),
          ANS=CONT,
          FRAMECNT=(100000,5000),
          INTERFACE=ETH3,
          LANTYPE=DYNAMIC
*
*
B31P171  PU ANS=CONT,
          ARPTAB=(2000,20),
          INNPOR=YES,
          PUTYPE=1,
          NPACOLL=NO,
          LPDA=BLOCK
*
*****
*
          NCST INTERFACES
*****
*
B31NCSTG GROUP NCST=IP, LNCTL=SDLC, ANS=CONT, ISTATUS=ACTIVE,
          VIRTUAL=YES
*
*
B31NCSTL LINE LINEFVT=CXSXFVT,
          PUFVT=CXSXFVT,
          LUFVT=(CXSXFVT,CXSXFVT),
          LINECB=CXSXLNK
*
*
B31NCSTP PU PUTYPE=2,
          PUCB=CXSP0000
*

```

Figure A-5 (Part 24 of 27). NCP B31 Sample Generation Definition

## NCP B31 Sample Generation Definition

```

*****
B31NCSB1 LU INTFACE=IPOWNER,REMLU=SNALB01,          * TO B01 *
              LUCB=(CXSL0000,CXSS0000),            *
              LOCADDR=1
*****
B31NCS1P LU INTFACE=INTF1,REMLU=(A03NCS1P),        * TO A03 *
              LUCB=(CXSL0001,CXSS0001),            *
              LOCADDR=2
B31NCS1B LU INTFACE=INTF1,REMLU=(A03NCS1B),        * TO A03 *
              LUCB=(CXSL0002,CXSS0002),            *
              LOCADDR=3
*****
B31NCS1C LU INTFACE=HOSTC01,REMLU=SNALC01,         * TO C01 *
              LUCB=(CXSL0003,CXSS0003),            *
              LOCADDR=4
*****
*      3746-900 TOKEN RING INTERFACE FOR INTERNAL IP CONNECTION      *
*****
B31LANG1 GROUP ECLTYPE=(PHY,ANY),ADAPTER=TIC3,ANS=CONT,MAXTSL=4000,  X
              USSTAB=AUSSTAB,ISTATUS=ACTIVE,XID=NO,          X
              RETRIES=(20,5,5)
B31TR44 LINE ADDRESS=(2144,FULL),TRSPEED=16,PORTADD=44,          X
              LOCADD=40016D102144
B31PU44A PU PUTYPE=1,NETWORK=IP,ADDR=02,P2PDEST=18.18.37.46,     X
              INTFACE=(,4000),LADDR=18.18.37.45,PROTOCOL=RIP,   X
              METRIC=1,SNETMASK=255.255.128.0,ARPTAB=(1)
*
*****
*      CHANNEL ADAPTER DEFINITIONS                                  *
*      CHANNELS ARE CODED AS TYPE 7 TO UTILIZE BCCA IF INSTALLED   *
*      IF NOT, CHANNEL DEFAULTS TO TYPE 6, CADS                    *
*****
*
B31XCA0 GROUP LNCTL=CA,                                          *
              CA=TYPE7,                                          *
              NCPCA=ACTIVE,                                       *
              TIMEOUT=180.0
*
*****
*      CA ADDR - 00          PHYSICAL PORT 5                      *
*****
*
B31CP5 LINE ADDRESS=P5,                                          *
              CASDL=420,                                          *
              NETID=NETB,                                          *
              DELAY=0.2
*
B31PP5A PU PUTYPE=5,                                          *
              TGN=1
*

```

Figure A-5 (Part 25 of 27). NCP B31 Sample Generation Definition

## NCP B31 Sample Generation Definition

```

*****
*   CA ADDR - 02           PHYSICAL PORT 7           *
*****
*
B31CP7  LINE ADDRESS=P7,                               *
        CASDL=420,                                     *
        NETID=NETC,                                   *
        DELAY=0.2
*
B31PP7A PU PUTYPE=5,                                   *
        TGN=1
*
*****
*   NON-NATIVE NETWORK DEFINITIONS FOR NETC         *
*****
*
NETC    NETWORK SUBAREA=03,SALIMIT=255,NETID=NETC,    *
        VRTIMER0=(180,,50),VRTIMER1=(180,,50),VRTIMER2=(180,,50)
*
        GWNAU NETID=NETA,NAME=A01N,NUMSESS=5,ELEMENT=1
        GWNAU NETID=NETA,NAME=A02N,NUMSESS=5,ELEMENT=2
        GWNAU NETID=NETA,NAME=A17N,NUMSESS=5,ELEMENT=3
        GWNAU NETID=NETA,NAME=A81N,NUMSESS=5,ELEMENT=4
        GWNAU NETID=NETB,NAME=B01N,NUMSESS=5,ELEMENT=6
        GWNAU NETID=NETB,NAME=B128N,NUMSESS=5,ELEMENT=7
*
        GWNAU NUMADDR=600
*
*****
*   PATH DECK FOR NON-NATIVE NETC                   *
*****
        PATH DESTSA=1,                               *
        ER0=(31,1,5000,5000,5000,20000),            *
        ER1=(1,1,5000,5000,5000,20000),            *
        VR0=1,                                       *
        VRPWS00=(1,3),VRPWS01=(1,3),VRPWS02=(1,3), *
        VR1=0,                                       *
        VRPWS10=(3,9),VRPWS11=(3,9),VRPWS12=(3,9)
        PATH DESTSA=4,                               *
        ER0=(31,1),ER1=(1,1),                       *
        VR0=1,                                       *
        VRPWS00=(2,6),VRPWS01=(2,6),VRPWS02=(2,6), *
        VR1=0,                                       *
        VRPWS10=(2,6),VRPWS11=(2,6),VRPWS12=(2,6)
        PATH DESTSA=31,                              *
        ER0=(31,1),ER1=(1,1),                       *
        VR0=0,                                       *
        VRPWS00=(1,3),VRPWS01=(1,3),VRPWS02=(1,3), *
        VR1=1,                                       *
        VRPWS10=(3,9),VRPWS11=(3,9),VRPWS12=(3,9)
*

```

Figure A-5 (Part 26 of 27). NCP B31 Sample Generation Definition

## NCP B31 Sample Generation Definition

```
*****
*   IP ROUTING DEFINITIONS   *
*****
*
*   IP OWNER IDENTIFICATION
*
*       IPOWNER INTERFACE=IPOWNER,HOSTADDR=191.91.1.1,
*           NUMROUTE=(25,25,25)
*
*   IP ADDRESSES ASSIGNED TO LOCAL NCP INTERFACES
*
*       NCST INTERFACES
*
*       IPLOCAL LADDR=191.91.1.99,INTERFACE=IPOWNER,METRIC=1,
*           P2PDEST=191.91.1.1,PROTOCOL=RIP
*       IPLOCAL LADDR=201.74.19.99,INTERFACE=HOSTC01,METRIC=1,
*           P2PDEST=201.74.19.1,PROTOCOL=RIP
*       IPLOCAL LADDR=128.81.0.99,INTERFACE=INTF1,METRIC=1,
*           P2PDEST=128.81.0.98,PROTOCOL=RIP
*
*       TOKEN RING INTERFACES
*
*       IPLOCAL LADDR=128.81.0.95,INTERFACE=TR92,METRIC=1,PROTOCOL=RIP
*
*       ETHERNET INTERFACE CHARACTERISTICS
*
*       IPLOCAL LADDR=191.91.2.99,INTERFACE=ETH1,METRIC=1,PROTOCOL=RIP
*       IPLOCAL LADDR=128.81.0.97,INTERFACE=ETH3,METRIC=1,PROTOCOL=RIP
*
*****
*   NCP GENEND MACRO - END OF GEN   *
*****
*
GENEND  GENEND
```

Figure A-5 (Part 27 of 27). NCP B31 Sample Generation Definition



## NCP B75 Sample Generation Definition

```
*****
      OPTIONS NEWDEFN=(YES,ECHO),USERGEN=(CXRNRF,CXNNT0)
*****
BPCCU01  PCCU AUTOSYN=YES, *
          BACKUP=YES, *
          CDUMPDS=CSPDUMP, *
          DUMPDS=VTAMDUMP, *
          MAXDATA=21384, *
          MDUMPDS=MOSSDUMP, *
          NETID=NETB, *
          OWNER=B128N, *
          SUBAREA=1028, *
          TGN=ANY
BPCCU02  PCCU AUTOSYN=YES, *
          BACKUP=YES, *
          CDUMPDS=CSPDUMP, *
          DUMPDS=VTAMDUMP, *
          MDUMPDS=MOSSDUMP, *
          MAXDATA=21384, *
          NETID=NETB, *
          OWNER=B01N, *
          SUBAREA=01, *
          TGN=ANY
*****
IFWB75   BUILD ADSESS=400, *
          AUXADDR=500, *
          BACKUP=50, *
          BFRS=128, *
          BRANCH=8000, *
          CATRACE=(YES,255), *
          CWALL=26, *
          DYNNSC=50, *
          DYNNSX=50, *
          DYNPOOL=(50,35), *
          ENABLTO=30.0, *
          ERLIMIT=16, *
          HPR=YES, *
          HPRQLIM=0, *
          LOADLIB=NCPL0AD, *
          LTRACE=8, *
```

Figure A-6 (Part 2 of 36). NCP B75 Sample Generation Definition

## NCP B75 Sample Generation Definition

```

MAXSSCP=8, *
MODEL=3745-210, *
NAMTAB=120, *
NETID=NETB, *
NEWNAME=IFWB75, *
NPA=(YES,DR), *
NRF.TRCTABL=2048, *
NUMHSAS=8, *
OLT=YES, *
PWROFF=YES, *
SALIMIT=2047, *
SESSACC=(YES,ALL,100,10000,1000,750,1,2,3,4,5,6), *
SLOWDOWN=12, *
SUBAREA=75, *
TRACE=(YES,100), *
TRANSFR=200, *
TYPGEN=NCP, *
TYP SYS=MVS, *
USGTIER=5, *
VERSION=V7R3, *
VRPOOL=254, *
VRTIMER0=(180,,50), *
VRTIMER1=(180,,50), *
VRTIMER2=(180,,50)
*****
      SYSCNTRL  OPTIONS=(SESSION,ENDCALL,MODE,RCNTRL,RCOND,RECMD,RIMM*
        ,XMTLMT,SSPAUSE,NAKLIM,BHSASSC,STORDSP,BACKUP,LNSTAT,SES*
        INIT)
*****
*      NCPNAU FOR NTO *
*****
NTO      NCPNAU NOTIFY=1, *
        NTO.TRACEML=YES, *
        NTO.TRCTABL=2500, *
        VIROWNER=CXNNT0, *
        TYPE=SSCP, *
        NAUCB=NTOSSCP, *
        NAUFVT=CXNFVTN

```

Figure A-6 (Part 3 of 36). NCP B75 Sample Generation Definition

## NCP B75 Sample Generation Definition

```
*****
*   HOST MACROS FOR CHANNEL ATTACHMENT   *
*****
HOSTB01  HOST BFRPAD=0,                  *
          MAXBFRU=100,                   *
          SUBAREA=01,                    *
          UNITSZ=256
HOSTB128 HOST BFRPAD=0,                  *
          MAXBFRU=100,                   *
          UNITSZ=256,                    *
          SUBAREA=1028
*****
*   PATH DEFINITIONS                     *
*****
      PATH DESTSA=1,                     *
          ER0=(1,1),ER2=(1,1),ER4=(1,1),ER6=(1,1),
          ER1=(31,1),ER3=(1,1),ER5=(1,1),ER7=(1,1),
          VR0=0,                          *
          VRPWS00=(1,3),VRPWS01=(1,3),VRPWS02=(1,3),
          VR1=1,                          *
          VRPWS10=(2,6),VRPWS11=(2,6),VRPWS12=(2,6),
          VR2=2,                          *
          VRPWS20=(2,6),VRPWS21=(2,6),VRPWS22=(2,6),
          VR3=3,                          *
          VRPWS30=(2,6),VRPWS31=(2,6),VRPWS32=(2,6),
          VR4=4,                          *
          VRPWS40=(3,9),VRPWS41=(3,9),VRPWS42=(3,9),
          VR5=5,                          *
          VRPWS50=(3,9),VRPWS51=(3,9),VRPWS52=(3,9),
          VR6=6,                          *
          VRPWS60=(3,9),VRPWS61=(3,9),VRPWS62=(3,9),
          VR7=7,                          *
          VRPWS70=(3,9),VRPWS71=(3,9),VRPWS72=(3,9)
```

Figure A-6 (Part 4 of 36). NCP B75 Sample Generation Definition



## NCP B75 Sample Generation Definition

```

PATH DESTSA=1028,
    ER0=(1028,1),ER2=(1028,1),ER4=(1028,1),ER6=(1028,1),
    ER1=(1028,1),ER3=(1028,1),ER5=(1028,1),ER7=(1028,1),
    VR0=0,
    VRPWS00=(1,3),VRPWS01=(1,3),VRPWS02=(1,3),
    VR1=1,
    VRPWS10=(2,6),VRPWS11=(2,6),VRPWS12=(2,6),
    VR2=2,
    VRPWS20=(2,6),VRPWS21=(2,6),VRPWS22=(2,6),
    VR3=3,
    VRPWS30=(2,6),VRPWS31=(2,6),VRPWS32=(2,6),
    VR4=4,
    VRPWS40=(3,9),VRPWS41=(3,9),VRPWS42=(3,9),
    VR5=5,
    VRPWS50=(3,9),VRPWS51=(3,9),VRPWS52=(3,9),
    VR6=6,
    VRPWS60=(3,9),VRPWS61=(3,9),VRPWS62=(3,9),
    VR7=7,
    VRPWS70=(3,9),VRPWS71=(3,9),VRPWS72=(3,9)
PATH DESTSA=(3,31),
    ER0=(31,1),ER2=(31,1),ER4=(31,1),ER6=(31,1),
    ER1=(31,1),ER3=(31,1),ER5=(31,1),ER7=(31,1),
    VR0=0,
    VRPWS00=(1,3),VRPWS01=(1,3),VRPWS02=(1,3),
    VR1=1,
    VRPWS10=(2,6),VRPWS11=(2,6),VRPWS12=(2,6),
    VR2=2,
    VRPWS20=(2,6),VRPWS21=(2,6),VRPWS22=(2,6),
    VR3=3,
    VRPWS30=(2,6),VRPWS31=(2,6),VRPWS32=(2,6),
    VR4=4,
    VRPWS40=(3,9),VRPWS41=(3,9),VRPWS42=(3,9),
    VR5=5,
    VRPWS50=(3,9),VRPWS51=(3,9),VRPWS52=(3,9),
    VR6=6,
    VRPWS60=(3,9),VRPWS61=(3,9),VRPWS62=(3,9),
    VR7=7,
    VRPWS70=(3,9),VRPWS71=(3,9),VRPWS72=(3,9)

```

\*

Figure A-6 (Part 5 of 36). NCP B75 Sample Generation Definition

## NCP B75 Sample Generation Definition

```
*****
* DIALSET FOR DIAL NTO 3101 USING V25BIS *
*****
SWITWX00 DIALSET LINES=LTWX00R, *
        QLIMIT=1, *
        QLOAD=0
SWITWX01 DIALSET LINES=LTWX01R, *
        QLIMIT=1, *
        QLOAD=0
*****
* PUDRPOOL/LUDRPOOL FOR DYNAMIC RECONFIGURATION *
*****
        PUDRPOOL NUMBER=100
        LUDRPOOL NUMTYP1=02, *
        NUMTYP2=100, *
        NUMILU=100
*****
***** SDLCST STATEMENTS FOR PRIMARY/SECONDARY STATION *****
*****
*
S75PRI SDLCST GROUP=B75GPRI, *
        MODE=PRI
S75SEC SDLCST GROUP=B75GSEC, *
        MODE=SEC
*
*****
* NTO REAL LINE 000 FOR SWITCHED 3101 (TWX) *
* DO NOT ACTIVATE THE REAL LINE *
*****
GSSNTOR GROUP CHAREC=(XOFF,8D), *
        CODE=ASCII, *
        DIAL=YES, *
        LNCTL=SS, *
        REPLYTO=23.5, *
        TEXTTO=23.5, *
        TYPE=NCP, *
        V25BIS=(YES,DLSDLC)
```

Figure A-6 (Part 6 of 36). NCP B75 Sample Generation Definition

## NCP B75 Sample Generation Definition

```

LTWX00R  LINE  ADDRESS=000,          *
          AUTO=YES,                 *
          CALL=INOUT,               *
          CLOCKNG=INT,SPEED=2400,   *
          CODE=ASCII,               *
          DIALSET=SWITWX00,        *
          DUPLEX=HALF,             *
          MONITOR=YES,             *
          ISTATUS=INACTIVE,        *
          REDIAL=1,                 *
          RETRIES=(3,1,2),         *
          RING=YES,                 *
          TERM=TWX,                 *
          USE=NCP,                  *
          V25BIS=(YES,DLSS)
TWX00D   TERMINAL BHSET=HEDIT16,   *
          CRDLAY=YES,              *
          CTERM=YES,               *
          FEATURE=(NOBREAK,ATTN),  *
          TERM=TWX
TWX00R   TERMINAL BHSET=HEDIT16,   *
          CRDLAY=YES,              *
          CTERM=NO,                *
          DIALNO=CRN47583,         *
          DIALSET=SWITWX00,       *
          FEATURE=(NOBREAK,ATTN),  *
          TERM=TWX
*
LTWX01R  LINE  ADDRESS=001,          *
          AUTO=YES,                 *
          CALL=INOUT,               *
          CLOCKNG=EXT,             *
          CODE=ASCII,               *
          DIALSET=SWITWX01,       *
          DUPLEX=HALF,             *

```

Figure A-6 (Part 7 of 36). NCP B75 Sample Generation Definition

## NCP B75 Sample Generation Definition

```

MONITOR=YES, *
ISTATUS=INACTIVE, *
REDIAL=1, *
RETRIES=(3,1,2), *
RING=YES, *
TERM=TWX, *
USE=NCP, *
V25BIS=(YES,DLS DLC)
TWX01D  TERMINAL BHSET=HEDIT16, *
        CRDLAY=YES, *
        CTERM=YES, *
        FEATURE=(NOBREAK,ATTN), *
        TERM=TWX
TWX01R  TERMINAL BHSET=HEDIT16, *
        CTERM=NO, *
        CRDLAY=YES, *
        DIALNO=CRN47583, *
        DIALSET=SWITWX01, *
        FEATURE=(NOBREAK,ATTN), *
        TERM=TWX
*****
*  BSC LINE WITH LPDATS=LPDA1 *
*****
B75GBS1  GROUP CLOCKNG=EXT, *
        CODE=EBCDIC, *
        CONV=YES, *
        CUTOFF=15, *
        DIAL=NO, *
        DUPLEX=FULL, *
        LNCTL=BSC, *
        LPDATS=LPDA1, *
        NEGPOLP=1, *
        PAUSE=0, *
        POLIMIT=(10,WAIT), *
        POLLED=YES, *
        REPLYTO=1, *

```

Figure A-6 (Part 8 of 36). NCP B75 Sample Generation Definition

## NCP B75 Sample Generation Definition

```

                RETRIES=(7,4,1),
                SERVLIM=2,
                SERVPRI=OLD,
                SESSION=2,
                TRANSFR=10,
                TYPE=NCP
*
B75B02  LINE ADDRESS=(002,HALF),
                SPEED=9600
*
B75C021  CLUSTER CUTYPE=3271,
                GPOLL=40407F7F
B75T021A  TERMINAL ADDR=60604040,
                SRT=(016,1),
                POLL=40404040,
                TERM=3277
*****
*  BSC LINE WITH LPDATS=LPDA2
*****
B75GBS2  GROUP CLOCKNG=EXT,
                CODE=EBCDIC,
                CONV=YES,
                CUTOFF=15,
                DIAL=NO,
                DUPLEX=FULL,
                LNCTL=BSC,
                LPDATS=LPDA2,
                NEGPOLP=1,
                PAUSE=0,
                POLIMIT=(10,WAIT),
                POLLED=YES,
                REPLYTO=1,
                RETRIES=(7,4,1),
                SERVLIM=2,
                SERVPRI=OLD,
                SESSION=2,
                TRANSFR=10,
                TYPE=NCP
*
B75B03  LINE ADDRESS=(003,HALF),
                SPEED=9600
*

```

Figure A-6 (Part 9 of 36). NCP B75 Sample Generation Definition

## NCP B75 Sample Generation Definition

```
B75C031 CLUSTER CUTYPE=3271, *
        GPOLL=40407F7F
B75T031A TERMINAL ADDR=60604040, *
        POLL=40404040, *
        SRT=(016,1), *
        TERM=3277
*
*****
* NTO VIRTUAL LINE FOR SWITCHED 3101 (TWX) *
* ONLY ACTIVATE THE VIRTUAL NTO LINE *
* SWITCHED MAJOR NODE IS V25NTO. *
* LU FOR LTWX00V IS T3101A. LU FOR LTWX01V IS T3101B. *
*****
GSSNTOV GROUP DIAL=YES, *
        ISTATUS=INACTIVE, *
        LNCTL=SDLC, *
        MAXLU=1, *
        TYPE=NCP, *
        USSTAB=HELLO, *
        VIROWNER=CXNNT0, *
        VIRTUAL=YES
LTWX00V LINE AUTO=YES, *
        CALL=INOUT, *
        NTO.CALLOUT=TWX00R, *
        NTO.ID=010011001111, *
        NTO.SSLINE=LTWX00R, *
        LINECB=CXNL1, *
        LINEFVT=CXNFVTV
PUTWX0V PU PUCB=CXNP1, *
        LUCB=(CXNU1,CXNU1,CXNU1), *
        PUFVT=CXNFVTP, *
        LUFVT=(CXNFVTL,CXNFVT1,CXNFVT2)
```

Figure A-6 (Part 10 of 36). NCP B75 Sample Generation Definition

## NCP B75 Sample Generation Definition

```

LTWX01V  LINE  AUTO=YES,
           CALL=INOUT,
           NTO.CALLOUT=TWX01R,
           NTO.ID=010011001111,
           NTO.SSLINE=LTWX01R,
           LINECB=CXNL2,
           LINEFVT=CXNFVTV
PUTWX1V  PU  PUCB=CXNP2,
           LUCB=(CXNU2,CXNU2,CXNU2),
           PUFVT=CXNFVTP,
           LUFVT=(CXNFVTL,CXNFVT1,CXNFVT2)
*****
*
*           NPM
*
*****
B75NPAG  GROUP LNCTL=SDLC,
           NPARSC=YES,
           VIRTUAL=YES

B75NPAL  LINE
B75NPAP  PU
B75NPLU1 LU
B75NPLU2 LU
B75NPLU3 LU
B75NPLU4 LU
B75NPLU5 LU
B75NPLU6 LU
B75NPLU7 LU
B75NPLU8 LU
*****
*  LINE 004 - SWITCHED 3276 USING V25BIS=SS
*  SWITCHED MAJOR NODE IS V25SDLC, LU IS B75L041A
*  LINE 032 - SWITCHED 3276 USING V25BIS=SDLC
*  SWITCHED MAJOR NODE IS V25SDLC, LU IS B75L321A
*****

```

Figure A-6 (Part 11 of 36). NCP B75 Sample Generation Definition

## NCP B75 Sample Generation Definition

```

GV25BIS  GROUP  DIAL=YES,          *
                LNCTL=SDLC,        *
                REPLYTO=3,         *
                TYPE=NCP,          *
                USSTAB=HELLO,      *
                V25BIS=(YES,DLSDLC), *
                XMITDLY=23.5
B75S04   LINE  ADDRESS=004,        *
                AUTO=YES,          *
                CALL=INOUT,        *
                CLOCKNG=INT,       *
                DUPLEX=HALF,       *
                PAUSE=1.0,         *
                REDIAL=(,3,5),     *
                RETRIES=(,3,5),    *
                RING=YES,          *
                SPEED=2400,        *
                V25BIS=(YES,DLSS)
B75P041  PU  AVGPB=140,           *
                PUTYPE=(1,2)
*
B75S32   LINE  ADDRESS=032,        *
                AUTO=YES,          *
                CALL=INOUT,        *
                CLOCKNG=EXT,       *
                DATMODE=FULL,      *
                DUPLEX=FULL,       *
                PAUSE=1.0,         *
                RETRIES=(,3,5),    *
                REDIAL=(,3,5),     *
                RING=YES,          *
                SPEED=1200,        *
                V25BIS=(YES,DLSDLC)
B75P321  PU  AVGPB=140,           *
                PUTYPE=(1,2)

```

Figure A-6 (Part 12 of 36). NCP B75 Sample Generation Definition



## NCP B75 Sample Generation Definition

```
*****
* LINE 033 - LEASED 3767 (#22) *
*****
B75GSDL1 GROUP ACTIVTO=420.0, *
          ANS=CONT, *
          CLOCKNG=EXT, *
          DIAL=NO, *
          DUPLEX=FULL, *
          LNCTL=SDLC, *
          MODETAB=MODSDLCT, *
          NRZI=NO, *
          REPLYTO=1, *
          RETRIES=(,3,5), *
          TYPE=NCP, *
          USSTAB=HELLO
B75S33  LINE ADDRESS=(033,FULL), *
          ISTATUS=INACTIVE, *
          MAXPU=6
          SERVICE ORDER=(B75P33C1),MAXLIST=6
B75P33C1 PU ADDR=C1, *
          AVGPB=20, *
          DLOGMOD=M3767, *
          IRETRY=YES, *
          MAXDATA=256, *
          MAXOUT=2, *
          PASSLIM=2, *
          PUDR=NO, *
          PUTYPE=1
B75L021A LU LOCADDR=0
```

Figure A-6 (Part 13 of 36). NCP B75 Sample Generation Definition

## NCP B75 Sample Generation Definition

```
*****
* LINE 034 - LEASED 3276'S WITH LPDATS=LPDA1 *
*****
B75GSDL2 GROUP ANS=CONT, *
                CLOCKNG=EXT, *
                DIAL=NO, *
                DUPLEX=FULL, *
                LNCTL=SDLC, *
                LPDATS=LPDA1, *
                NRZI=YES, *
                TYPE=NCP, *
                USSTAB=HELLO
B75S34  LINE ADDRESS=034, *
                ISTATUS=INACTIVE, *
                MAXPU=5, *
                RETRIES=(7,4,3)
                SERVICE ORDER=(B75P34C1,B75P34C2),MAXLIST=5
B75P34C1 PU ADDR=C1, *
                IRETRY=NO, *
                MAXDATA=265, *
                MAXOUT=2, *
                PASSLIM=2, *
                PUDR=YES, *
                PUTYPE=2, *
                SRT=(256,4)
B75L341A LU LOCADDR=02, *
                PACING=1
B75L341B LU LOCADDR=03, *
                PACING=1
B75P34C2 PU ADDR=C2, *
                IRETRY=NO, *
                MAXDATA=265, *
                MAXOUT=2, *
                PASSLIM=2, *
                PUDR=YES, *
                PUTYPE=2, *
                SRT=(256,4)
B75L342A LU LOCADDR=02, *
                PACING=1
B75L342B LU LOCADDR=03, *
                PACING=1
```

Figure A-6 (Part 14 of 36). NCP B75 Sample Generation Definition

## NCP B75 Sample Generation Definition

```
*****
* LINE 035 - LEASED 3276'S WITH LPDATS=LPDA2 *
*****
B75GSDL3 GROUP ANS=CONT, *
                CLOCKNG=EXT, *
                DIAL=NO, *
                DUPLEX=FULL, *
                LNCTL=SDLC, *
                LPDATS=LPDA2, *
                NRZI=YES, *
                TYPE=NCP, *
                USSTAB=HELLO
B75S35  LINE ADDRESS=035, *
                ISTATUS=INACTIVE, *
                MAXPU=5, *
                RETRIES=(7,4,3)
                SERVICE ORDER=(B75P35C1,B75P35C2),MAXLIST=5
B75P35C1 PU ADDR=C1, *
                IRETRY=NO, *
                MAXDATA=265, *
                MAXOUT=2, *
                PASSLIM=2, *
                PUDR=YES, *
                PUTYPE=2, *
                SRT=(256,4)
B75L351A LU LOCADDR=02, *
                PACING=1
B75L351B LU LOCADDR=03, *
                PACING=1
```

Figure A-6 (Part 15 of 36). NCP B75 Sample Generation Definition

## NCP B75 Sample Generation Definition

```

B75P35C2 PU ADDR=C2, *
                IRETRY=NO, *
                MAXDATA=265, *
                MAXOUT=2, *
                PASSLIM=2, *
                PUDR=YES, *
                PUTYPE=2, *
                SRT=(256,4)
B75L352A LU LOCADDR=02, *
                PACING=1
B75L352B LU LOCADDR=03, *
                PACING=1
*****
* LINE 036 - 3276 WITH DUMMY PU/LU FOR DYNAMIC RECONFIGURATION *
*****
B75S36  LINE ADDRESS=036, *
                ISTATUS=INACTIVE, *
                MAXPU=5, *
                RETRIES=(7,4,3)
                SERVICE MAXLIST=5
B75P36C1 PU ADDR=C1, *
                ANS=CONT, *
                IRETRY=YES, *
                ISTATUS=INACTIVE, *
                LOGTAB=INTERP, *
                MAXDATA=256, *
                MAXOUT=7, *
                MODETAB=AMODETAB, *
                PASSLIM=5, *
                PUDR=YES, *
                PUTYPE=2, *
                USSTAB=AUSSTAB, *
                XID=YES
B75L361A LU LOCADDR=1, *
                PACING=7
B75L361B LU LOCADDR=2, *
                PACING=7

```

Figure A-6 (Part 16 of 36). NCP B75 Sample Generation Definition

## NCP B75 Sample Generation Definition

```

B75L361C LU LOCADDR=3,          *
          PACING=7
B75L361D LU LOCADDR=4,          *
          PACING=7
B75I361A LU DLOGMOD=PARALLEL,   *
          LOCADDR=0,            *
          PACING=7,             *
          RESSCB=05
B75I361B LU DLOGMOD=PARALLEL,   *
          LOCADDR=0,            *
          PACING=7,             *
          RESSCB=05
B75I361C LU DLOGMOD=PARALLEL,   *
          LOCADDR=0,            *
          PACING=7,             *
          RESSCB=05
B75I361D LU DLOGMOD=PARALLEL,   *
          LOCADDR=0,            *
          PACING=7,             *
          RESSCB=05
*
B75P3623 PU ADDR=C3,           *
          IRETRY=YES,           *
          ISTATUS=INACTIVE,     *
          LOGTAB=INTERP,        *
          MAXDATA=256,          *
          MAXOUT=7,             *
          MODETAB=AMODETAB,     *
          PASSLIM=5,            *
          PUDR=YES,ANS=CONT,    *
          PUTYPE=2,             *
          USSTAB=AUSSTAB,      *
          XID=YES
*
B75L363A LU LOCADDR=1,          *
          PACING=7
B75L363B LU LOCADDR=2,          *
          PACING=7
B75L363C LU LOCADDR=3,          *
          PACING=7

```

Figure A-6 (Part 17 of 36). NCP B75 Sample Generation Definition

## NCP B75 Sample Generation Definition

```
B75L363D LU LOCADDR=4, *
          PACING=7
B75I363A LU LOCADDR=0, *
          RESSCB=05, *
          PACING=7, *
          DLOGMOD=PARALLEL
B75I363B LU LOCADDR=0, *
          RESSCB=05, *
          PACING=7, *
          DLOGMOD=PARALLEL
B75I363C LU LOCADDR=0, *
          RESSCB=05, *
          PACING=7, *
          DLOGMOD=PARALLEL
B75I363D LU LOCADDR=0, *
          RESSCB=05, *
          PACING=7, *
          DLOGMOD=PARALLEL
*
*****
* LINE 016 - NORMAL GROUP POLL LINE WITH GP3174=A1 -- 3174#8 (FULL) *
*****
GRPOLL GROUP LNCTL=SDLC, *
        DIAL=NO, *
        GP3174=A1
B75S16 LINE ADDRESS=(016,FULL), *
        CLOCKNG=EXT, *
        DUPLEX=FULL, *
        MODULO=8, *
        PAUSE=2.0, *
        MODETAB=NRFLG, *
        NRZI=NO, *
        TRANSFR=20, *
        USSTAB=AUSSTAB
*
* 3174 CONTROL TERMINALS
*
```

Figure A-6 (Part 18 of 36). NCP B75 Sample Generation Definition

## NCP B75 Sample Generation Definition

```
B75P16C1 PU ADDR=C1, *
          PUTYPE=2
B75L161A LU LOCADDR=2, *
          PACING=0
B75L161B LU LOCADDR=3, *
          PACING=0
*
* PS2N60
*
B75P16C2 PU ADDR=C2, *
          PUTYPE=2
B75L162A LU LOCADDR=2, *
          PACING=3
B75L162B LU LOCADDR=3, *
          PACING=3
B75L162C LU LOCADDR=4, *
          PACING=3
B75L162D LU LOCADDR=5, *
          PACING=3
*
* PS2N50
*
B75P16C3 PU ADDR=C3, *
          PUTYPE=2
B75L163A LU LOCADDR=2, *
          PACING=0
*
* PS2N51
*
B75P16C4 PU ADDR=C4, *
          PUTYPE=2
B75L164A LU LOCADDR=2, *
          PACING=0
*
```

Figure A-6 (Part 19 of 36). NCP B75 Sample Generation Definition

## NCP B75 Sample Generation Definition

```
* PC23
*
B75P16C5 PU ADDR=C5,
          PUTYPE=2
B75L165A LU LOCADDR=2,
          PACING=0
*
*****
* LINE 020 - NORMAL GROUP POLL LINE WITH GP3174=A1 -- 3174#8 (HALF) *
*****
B75S20  LINE ADDRESS=(020,HALF),
          CLOCKNG=EXT,
          DUPLEX=HALF,
          MODULO=8,
          PAUSE=2.0,
          MODETAB=NRFLG,
          NRZI=NO,
          TRANSFR=20,
          USSTAB=AUSSTAB
*
* 3174 CONTROL TERMINALS
*
B75P20C1 PU ADDR=C1,
          PUTYPE=2
B75L201A LU LOCADDR=2,
          PACING=0
B75L201B LU LOCADDR=3,
          PACING=0
*
* PS2N60
*
B75P20C2 PU ADDR=C2,
          PUTYPE=2
B75L202A LU LOCADDR=2,
          PACING=3
B75L202B LU LOCADDR=3,
          PACING=3
```

Figure A-6 (Part 20 of 36). NCP B75 Sample Generation Definition



## NCP B75 Sample Generation Definition

```
B75L202C LU LOCADDR=4,          *
          PACING=3
B75L202D LU LOCADDR=5,          *
          PACING=3
*
* PS2N50
*
B75P20C3 PU ADDR=C3,           *
          PUTYPE=2
B75L203A LU LOCADDR=2,          *
          PACING=0
*
* PS2N51
*
B75P20C4 PU ADDR=C4,           *
          PUTYPE=2
B75L204A LU LOCADDR=2,          *
          PACING=0
*
* PC23
*
B75P20C5 PU ADDR=C5,           *
          PUTYPE=2
B75L205A LU LOCADDR=2,          *
          PACING=0
*
```

Figure A-6 (Part 21 of 36). NCP B75 Sample Generation Definition

## NCP B75 Sample Generation Definition

```

*****
*
*           VIRTUAL DEFINITIONS FOR NRF R7
*
*****
GN75R7  GROUP DIAL=NO,
          LNCTL=SDLC,
          MODETAB=NRFLG,
          PACING=0,
          VIRTUAL=YES,
          VIROWNER=CXRNR,
          VPACING=0
*
N75LINE LINE LINEFVT=CXRFVT,
          LINECB=CXRLNK,
          LUFVT=(CXRFVT,CXRFVT),
          PUFVT=CXRFVT
*
* PU1 NRF SESSION PARTNER ROUTING
*
N75PU1  PU
*
N75LU1A LU   NRF.SESSPART=N75LU1D,
          NRF.LUCAP=PRIMARY,
          NUMSESS=255
N75LU1B LU   NRF.SESSPART=N75LU1F
N75LU1C LU   NRF.SESSPART=N75LU1G
N75LU1D LU   NRF.SESSPART=N75LU1A,
          NUMSESS=255
N75LU1F LU   NRF.AUTOINIT=(B75L161A,NRFB,ENQ),
          NRF.SESSPART=N75LU1B
N75LU1G LU   NRF.AUTOINIT=(B75L161B,NRFB,ENQ),
          NRF.SESSPART=N75LU1C
*
* PU2 NRF TABLE, CORRELATION AND ARGUMENT ROUTING
*

```

Figure A-6 (Part 22 of 36). NCP B75 Sample Generation Definition

## NCP B75 Sample Generation Definition

```

N75PU2  PU
*
N75LU2A LU   NRF.ROUTE=FBTAB
N75LU2B LU   NRF.ROUTE=FBCTAB
N75LU2C LU   NRF.ROUTE=FBCTAB
N75LU2D LU   NRF.LOCATE=LOCAT1,
              NRF.ROUTE=ARG1TB,
              X
N75LU2F LU   NRF.CORRLTE=60,
              NRF.LOCATE=LOCAT2,
              X
N75LU2G LU   NRF.CORRLTE=60,
              NRF.LOCATE=LOCAT2,
              X
N75LU2H LU   NRF.CORRLTE=0,
              NRF.LOCATE=LOCAT2,
              X
N75LU2I LU   NRF.CORRLTE=0
*
* PU3 NRF TABLE AND ARGUMENT ROUTING
*
N75PU3  PU
*
N75LU3A LU   NRF.ROUTE=FXTAB1
N75LU3B LU   NRF.DEFAULT=N75LU2B,
              NRF.ROUTE=FXTAB2,
              X
N75LU3C LU   NRF.DEFAULT=N75LU2B,
              NRF.ROUTE=FXTAB3,
              X
N75LU3D LU   NRF.ROUTE=FXTAB4
N75LU3E LU   NRF.LUCAP=PRIMARY,
              NRF.ROUTE=FXTABO,
              X
N75LU3F LU   NRF.LUCAP=SECONDARY,
              NRF.ROUTE=FXTABI,
              X
N75LU3G LU   NRF.LOCATE=LOCAT2,
              NRF.ROUTE=ARGTAB,
              X
N75LU3H LU   NRF.LOCATE=LOCAT2,
              NRF.ROUTE=ARGTAB,
              X
N75LU3I LU   NRF.ROUTE=FXTABC
N75LU3J LU   NRF.ROUTE=FXTABN
*

```

Figure A-6 (Part 23 of 36). NCP B75 Sample Generation Definition

## NCP B75 Sample Generation Definition

```
* PU4 NRF CORRELATION ROUTING
*
N75PU4  PU
*
N75LU4A LU    NRF.CORRLTE=60,           X
              NRF.DELAYTO=90,         X
              NRF.TAGLEN=2
*
FXTAB0  NRF.ROUTETAB
        NRF.ENTRY  ROUTDEST=N75LU3J
        NRF.TABEND
*
FXTAB3  NRF.ROUTETAB
        NRF.ENTRY  ROUTDEST=N75LU3F
        NRF.TABEND
*
FXTAB1  NRF.ROUTETAB
        NRF.ENTRY  ROUTDEST=N75LU3I
        NRF.TABEND
*
FXTAB1  NRF.ROUTETAB
        NRF.ENTRY  ROUTDEST=N75LU2F
        NRF.TABEND
*
FXTAB2  NRF.ROUTETAB
        NRF.ENTRY  ROUTDEST=N75LU2G
        NRF.TABEND
*
FXTAB3  NRF.ROUTETAB
        NRF.ENTRY  ROUTDEST=N75LU2H
        NRF.TABEND
*
FXTAB4  NRF.ROUTETAB
        NRF.ENTRY  ROUTDEST=N75LU4A
        NRF.TABEND
*
```

Figure A-6 (Part 24 of 36). NCP B75 Sample Generation Definition

## NCP B75 Sample Generation Definition

```

FBCTAB  NRF.ROUTETAB
        NRF.ENTRY  ROUTDEST=(N75LU2F,N75LU2G,N75LU2H,N75LU2I,N75LU4A)
        NRF.TABEND
*
FXTABN  NRF.ROUTETAB
        NRF.ENTRY  ROUTDEST=N75LU3E
        NRF.TABEND
*
ARGTAB  NRF.ROUTETAB
        NRF.ENTRY  ROUTEARG='C6C1'X,ROUTDEST=N75LU3I
        NRF.ENTRY  ROUTEARG='C6C2'X,ROUTDEST=N75LU3J
        NRF.ENTRY  ROUTEARG='C6C3'X,ROUTDEST=N75LU2A
        NRF.ENTRY  ROUTEARG='C6C4'X,ROUTDEST=N75LU2B
        NRF.TABEND
*
FBTAB   NRF.ROUTETAB
        NRF.ENTRY  ROUTDEST=(N75LU3E,N75LU3F,N75LU3G,N75LU3B,N75LU3C)
        NRF.TABEND
*
ARG1TB  NRF.ROUTETAB
        NRF.ENTRY  ROUTEARG='C6'X,
        ROUTDEST=(N75LU3E,N75LU3G,N75LU3H,N75LU2C,N75LU2G)
        NRF.ENTRY  ROUTEARG='C7'X,
        ROUTDEST=(N75LU3F,N75LU3H,N75LU2C,N75LU2G)
        NRF.ENTRY  ROUTEARG='C8'X,
        ROUTDEST=(N75LU3E,N75LU3G,N75LU2A,N75LU2H)
        NRF.ENTRY  ROUTEARG='C9'X,
        ROUTDEST=(N75LU3I,N75LU3G,N75LU3J,N75LU2B)
        NRF.TABEND
*
LOCAT1  NRF.LOCATE  FORMAT=(2,1)
LOCAT2  NRF.LOCATE  FORMAT=(2,2)
*

```

Figure A-6 (Part 25 of 36). NCP B75 Sample Generation Definition

## NCP B75 Sample Generation Definition

```
*****
* FRAME RELAY PHYSICAL GROUP - FULL DUPLEX *
*****
B75FRGP1 GROUP FRELAY=PHYSICAL, *
          ISTATUS=ACTIVE, *
          TYPE=NCP, *
          XMONLNK=YES, *
          DIAL=NO, *
          LNCTL=SDLC, *
          NPACOLL=(YES,EXTENDED), *
          PUTYPE=1
*
*****
* FRAME RELAY PHYSICAL LINE 48 - FULL DUPLEX 56KB *
*****
B75F48  LINE ADDRESS=(048,FULL), *
          CLOCKNG=EXT, *
          MAXFRAME=2106, *
          NRZI=NO, *
          SPEED=56000
B75P48  PU ERRORT=(3,4), *
          LMI=ANSI, *
          SPOLL=6, *
          TIMERS=(10,15), *
          PUDR=NO, *
          NPACOLL=(YES,EXTENDED), *
          INNPORT=YES, *
          ANS=CONTINUE
*
B75P48A PU DLCI=(80,D), *
          NPACOLL=(YES,EXTENDED), *
          INNPORT=YES, *
          ANS=CONTINUE
*
```

Figure A-6 (Part 26 of 36). NCP B75 Sample Generation Definition

## NCP B75 Sample Generation Definition

```

B75P48B  PU DLCI=(81,D),
          NPACOLL=(YES,EXTENDED),
          INNPOR=YES,
          ANS=CONTINUE
*
* FRSE PU TO BE ADDED USING VTAM 4.1 PERM DR
*B75P48C PU  ADDR=52
*
*****
* FRAME RELAY PHYSICAL LINE 1036 - FULL DUPLEX HPTSS
*****
B75F1036 LINE ADDRESS=(1036,FULL),
          CLOCKNG=EXT,
          MAXFRAME=2106,
          NRZI=NO,
          SPEED=1544000
B75P1036 PU ERROR=(3,4),
          LMI=CCITT,
          SPOLL=6,
          TIMERS=(10,15),
          PUDR=NO,
          NPACOLL=(YES,EXTENDED),
          INNPOR=YES,
          ANS=CONTINUE
*
B75P36A  PU DLCI=(30,D),
          NPACOLL=(YES,EXTENDED),
          INNPOR=YES,
          ANS=CONTINUE
*
B75P36B  PU DLCI=(46,D),
          NPACOLL=(YES,EXTENDED),
          INNPOR=YES,
          ANS=CONTINUE
*
* FRSE PU TO BE ADDED USING VTAM 4.1 PERM DR
*B75P36C PU  ADDR=3E
*

```

Figure A-6 (Part 27 of 36). NCP B75 Sample Generation Definition

## NCP B75 Sample Generation Definition

```
*****
* FRAME RELAY LOGICAL INN LINES FOR B75F48 *
*****
B75FRGL1 GROUP FRELAY=LOGICAL, *
          ISTATUS=ACTIVE, *
          MAXOUT=127, *
          MODULO=128, *
          PHYSRSC=B75P48, *
          RETRIES=(5,5,5), *
          SDLCST=(S75PRI,S75SEC), *
          TYPE=NCP, *
          DIAL=NO, *
          LNCTL=SDLC, *
          LEVEL2=ECLNAVL2, *
          LEVEL3=ECLNAVL3, *
          LEVEL5=NCP, *
          XIO=(ECLNAVXL,ECLNAVXS,ECLNAVXI,ECLNAVXK), *
          LINEADD=NONE, *
          NPACOLL=(YES,EXTENDED), *
          PUTYPE=4, *
          COMPSWP=NO, *
          COMPOWN=YES
*
*****
* LOGICAL LINE 1 --- DLCI X'60' TALKS TO DLCI X'50' IN NCP IFWB31 *
*****
B75LL1A LINE ISTATUS=ACTIVE, *
          MONLINK=YES, *
          IPL=YES, *
          UACB=X$L1B
B75PL1A PU ANS=CONTINUE, *
          PUTYPE=4, *
          TGN=1, *
          DLCI=(96,D), *
          NPACOLL=NO
```

Figure A-6 (Part 28 of 36). NCP B75 Sample Generation Definition



## NCP B75 Sample Generation Definition

```

*****
* FRAME RELAY PHYSICAL PERIPHERAL GROUP - FULL DUPLEX *
*****
B75FRGP2 GROUP FRELAY=(PHY,PER), *
                ISTATUS=ACTIVE, *
                TYPE=NCP, *
                DIAL=NO, *
                LNCTL=SDLC, *
                NPACOLL=(YES,EXTENDED), *
                PUTYPE=1
*
*****
* FRAME RELAY PHYSICAL LINE 52 - FULL DUPLEX 56 KB *
* - BAN/BNN CONNECTION *
*****
B75F52 LINE ADDRESS=(052,FULL), *
                MAXFRAME=2106, *
                LOCADD=4FFF00000000, *
                CLOCKNG=EXT, *
                NRZI=NO, *
                SPEED=56000
B75P52 PU LMI=ANSI, *
                SPOLL=6, *
                ERRORT=(3,4), *
                TIMERS=(10,15), *
                PUDR=NO, *
                NPACOLL=(YES,EXTENDED), *
                INNPORT=YES, *
                ANS=CONTINUE
*
*****
* FRAME RELAY LOGICAL BNN LINES - PHYRSC=B75P52 *
*****
B75FRBG1 GROUP FRELAY=(LOGICAL,PER), X
                ANS=CONTINUE, X
                AUTOGEN=10, X
                CALL=INOUT, X
                MODETAB=AMODETAB, X

```

Figure A-6 (Part 29 of 36). NCP B75 Sample Generation Definition

## NCP B75 Sample Generation Definition

```

                ISTATUS=ACTIVE,                                X
                LOCALTO=6,                                    X
                PHYSRSC=B75P52,                              X
                USSTAB=AMODETAB,                              X
                RETRIES=(10,0,0),                             X
                XID=YES,                                      X
                DYNPU=YES,                                    X
                DYNPUFX=DF,                                   X
                XMIDTLY=NONE
*****
***** SDLC GROUP FOR PRIMARY/SECONDARY STATION             *****
*****
*
B75GPRI  GROUP  ACTIVTO=60.0,                                *
                DIAL=NO,                                    *
                LNCTL=SDLC,                                *
                MODE=PRI,                                   *
                REPLYTO=30,                                 *
                TYPE=NCP
*
B75GSEC  GROUP  ACTIVTO=60.0,                                *
                DIAL=NO,                                    *
                LNCTL=SDLC,                                *
                MODE=SEC,                                   *
                TYPE=NCP
*
*****
*      NCP TOKEN-RING INTERCONNECT PHYSICAL LINES          *
*****
*
B75NTRP1 GROUP  ECLTYPE=(PHYSICAL,ANY),                      *
                ANS=CONTINUE,                               *
                RETRIES=(20,5,5),                          *
                USSTAB=AUSSTAB,                             *
                XID=NO,                                     *
                TYPE=NCP,                                    *
                DIAL=NO,                                    *
                LNCTL=SDLC,                                *
                LEVEL2=ECLNARL2,                           *
                LEVEL3=ECLNARL3,                           *
                LEVEL5=NCP,                                 *
                TIMER=(ECLNART1,,ECLNART2,ECLNART3),       *
                XIO=(ECLNARXL,ECLNARXS,ECLNARXI,ECLNARXK), *
                USERID=(5668854,ECLRBDT,NORECMS,,ECLNMVT), *

```

Figure A-6 (Part 30 of 36). NCP B75 Sample Generation Definition

## NCP B75 Sample Generation Definition

```

SPEED=9600, *
NPACOLL=NO, *
PUTYPE=1, *
PUDR=NO, *
COMPTAD=YES, *
COMPSWP=YES, *
COMPOWN=YES
*****
* ADDRESS 1088: NTRI PHYSICAL LINE - SUBAREA/PERIPHERAL *
*****
*
B75TR88 LINE ADDRESS=(1088,FULL), *
ADAPTER=TIC2, *
LOCADD=400000007531, *
PORTADD=1, *
MAXFRAME=2106, *
TRSPEED=4, *
UACB=(X$P1AX,X$P1AR)
*
B75PU88 PU ADDR=01, *
INNPORT=YES
*
B75PU88B PU NETWORK=FRELAY,COMRATE=(,3),PUTYPE=1,ADDR=03
*
*****
* NTRI PERIPHERAL LOGICAL CONNECTIONS FOR 1088 *
*****
*
B75NTRL1 GROUP ECLTYPE=LOGICAL, *
ANS=CONTINUE, *
AUTOGEN=50, *
CALL=INOUT, *
MODETAB=AMODETAB, *

```

Figure A-6 (Part 31 of 36). NCP B75 Sample Generation Definition

## NCP B75 Sample Generation Definition

```

PHYPORT=NONE,
PHYSRSC=NONE,
NPACOLL=(YES,EXTENDED),
RETRIES=(10,4,10,6),
RNRLIMIT=3,
USSTAB=AUSSTAB,
XMITDLY=NONE,
TYPE=NCP,
DIAL=YES,
LNCTL=SDLC,
LEVEL2=ECLNAVL2,
LEVEL3=ECLNAVL3,
LEVEL5=NCP,
XIO=(ECLNAVXL,ECLNAVXS,ECLNAVXI,ECLNAVXK),
USERID=(5668854,ECLVBDT,NORECMS,,ECLNMVT),
LINEADD=NONE,
LINEAUT=YES,
PUTYPE=2,
COMPOWN=YES
*
*****
*   NTRI SUBAREA LOGICAL CONNECTIONS FOR 1088   *
*   TO IFWB31 1092                               *
*****
*
B75NTRL2 GROUP ECLTYPE=(LOGICAL,SUBAREA),
ANS=CONTINUE,
MODETAB=AMODETAB,
PHYPORT=1,
PHYSRSC=B75PU88,
SDLCST=(S75PRI,S75SEC),
USSTAB=AUSSTAB,
TYPE=NCP,
DIAL=NO,
LNCTL=SDLC,
LEVEL2=ECLNAVL2,
LEVEL3=ECLNAVL3,

```

Figure A-6 (Part 32 of 36). NCP B75 Sample Generation Definition

## NCP B75 Sample Generation Definition

```

LEVEL5=NCP,
XIO=(ECLNAVXL,ECLNAVXS,ECLNAVXI,ECLNAVXK),
USERID=(5668854,ECLVBDT,NORECMS,,ECLNMVT),
LINEADD=NONE,
NPACOLL=NO,
PUTYPE=4,
COMPOWN=YES,
RETRIES=(6,0,0,6)
*
B75LG2A LINE TGN=1,
          UACB=X$L51A
*
B75PG2A PU ADDR=04400000017335
*
*****
* LOGICAL DEFINITIONS FOR FRAME RELAY PORT B75PU88B
*****
*
B75FRTG1 GROUP ECLTYPE=(LOGICAL,FRELAY),PUTYPE=1,TYPE=NCP,DIAL=NO, X
              LNCTL=SDLC,LINEADD=NONE,COMPOWN=YES,RETRIES=(6,0,0,6), X
              PHYSRSC=B75PU88B
B75LFR3A LINE MAXFRAME=2106,NPACOLL=(YES,EXTENDED),MAXPU=240, X
              COMRATE=(,1)
B75LM88A PU LMI=ANSI,ANS=CONT,ADDR=C44000000C0431
*
B75P88A PU DLCI=(96,D),
          NPACOLL=(YES,EXTENDED),
          INNPORT=YES,
          ANS=CONTINUE
*
B75P88B PU DLCI=(97,D),
          NPACOLL=(YES,EXTENDED),
          INNPORT=YES,
          ANS=CONTINUE
*
* FRSE PU TO BE ADDED USING VTAM 4.1 PERM DR
*B75P88C PU ADDR=62
*

```

Figure A-6 (Part 33 of 36). NCP B75 Sample Generation Definition

## NCP B75 Sample Generation Definition

```
*****
* FRSESET DEFINITIONS *
*****
PVCSET1 FRSESET SUBPORTS=(B75P36A,B75P88A,,B75P48A)
PVCSET2 FRSESET SUBPORTS=(B75P36B,B75P88B,,B75P48B)
* FRSESET TO BE ADDED USING VTAM 4.1 PERM DR
*PVCSET3 FRSESET SUBPORTS=(B75P36C,B75P88C,,B75P48C)
*****
*
* CHANNEL ADAPTERS *
*
*****
B75CAG1 GROUP LNCTL=CA, *
          CA=TYPE7, *
          ISTATUS=ACTIVE, *
          NPCCA=ACTIVE, *
          NPACOLL=YES, *
          TIMEOUT=480.0
*****
* CA ADDR - 00 PHYSICAL PORT 5 -- TGN=1 CONNECT TO HOST B01N *
* OR B128N PUTYPE=5 CONNECTION *
*****
B75C00 LINE ADDRESS=00, *
          CASDL=420, *
          DELAY=0.2
B75P00A PU PUTYPE=5, *
          TGN=1
*****
* CA ADDR - 02 PHYSICAL PORT 7 -- TGN=1 *
* CASUAL CONNECT TO HOST B128. SEE ALSO LOCAL SNA DECK B28CCN, *
* B28APPLS, AND S28APPLA *
*****
B75C02 LINE ADDRESS=02, *
          CASDL=420, *
          DELAY=0.2
```

Figure A-6 (Part 34 of 36). NCP B75 Sample Generation Definition

## NCP B75 Sample Generation Definition

```

B75P02A  PU LIMRES=YES,      ** LIMITED RESOURCE TERMINATION      ***
          PUTYPE=2           ** FOR CCN,PU MUST EQUAL 2          **
ECHOB28A LU LOCADDR=0       ** APPLS THAT CAN HAVE SESSIONS TO    **
ECHOB28B LU LOCADDR=0       ** LUS DEFINED IN B28CCN          **
S28APPLA LU LOCADDR=0       ** LIMITED RESOURCE APPL          **
*****
*   CA ADDR - 08  PHYSICAL PORT 1 -- TGN=1 CONNECT TO HOST B01N   *
*   OR B128 PUTYPE=5 CONNECTION                                     *
*****
B75C08   LINE ADDRESS=08,    *
          CASDL=420,         *
          DELAY=0.2          *
B75P08A  PU PUTYPE=5,        *
          TGN=1              *
*****
*   CA ADDR - 10  PHYSICAL PORT 3                                   *
*   CASUAL CONNECT (T2.1) TO HOST B127 OR B128                     *
*****
B75C10   LINE ADDRESS=10,    *
          CASDL=420,         *
          DELAY=0.2          *
B75P10A  PU LIMRES=YES,      ** LIMITED RESOURCE TERMINATION      ***
          PUTYPE=2           ** FOR CCN,PU MUST EQUAL 2          **
*****
*   BLOCK HANDLERS FOR NTO                                          *
*****
BH01PT1  STARTBH BHEXEC=PT1
          DATETIME DATE=YES,      *
          DATEFMT=YY.DDD,        *
          INSERT=ALL,           *
          TIME=YES
          ENDBH
BH01PT3  STARTBH BHEXEC=PT3
          DATETIME DATE=YES,      *
          DATEFMT=YY.DDD,        *
          INSERT=ALL,           *
          TIME=YES
          ENDBH

```

Figure A-6 (Part 35 of 36). NCP B75 Sample Generation Definition

## NCP B75 Sample Generation Definition

```

BH03PT2  STARTBH BHEXEC=PT2
          DATETIME DATE=YES,
          DATEFMT=YY/MM/DD,
          INSERT=ALL,
          PT2EXEC=AFTER,
          TIME=YES
          ENDBH
*
HBH001   STARTBH BHEXEC=PT2
          REMOVCTL
          ENDBH
HBH002   STARTBH BHEXEC=PT2
          DATETIME DATE=YES,
          DATEFMT=MM/DD/YY,
          INSERT=FIRST
          ENDBH
HHEDIT16 STARTBH BHEXEC=PT3
          EDIT BKSP=16
          ENDBH
HHEDIT50 STARTBH BHEXEC=PT3
          EDIT BKSP=50
          ENDBH
*
SET004   BHSET EXEC=YES,
          PT1=BH01PT1,
          PT2=BH03PT2,
          PT3=BH01PT3
          *
          *
          *
SET007   BHSET EXEC=YES,
          PT1=BH01PT1,
          PT3=BH01PT3
          *
          *
          *
HBHSET1  BHSET EXEC=YES,
          PT2=HBH001
          *
HEDIT2   BHSET PT3=HBH002
HEDIT16  BHSET PT3=HHEDIT16
HEDIT50  BHSET PT3=HHEDIT50
*
GENEND   GENEND

```

Figure A-6 (Part 36 of 36). NCP B75 Sample Generation Definition





## NCP C04 Sample Generation Definition

```
MAXDATA=21384, *
NETID=NETC, *
OWNER=C01N, *
SUBAREA=01, *
TGN=ANY
*****
IFWC04 BUILD ADSESS=4, *
AUXADDR=5, *
BACKUP=50, *
BFRS=128, *
BRANCH=8000, *
CATRACE=(YES,255), *
CWALL=26, *
DYNNSC=50, *
DYNNSX=50, *
DYNPOOL=(50,35), *
ENABLTO=30.0, *
ERLIMIT=16, *
LOADLIB=NCPLoad, *
LTRACE=8, *
MAXSSCP=8, *
MODEL=3745-170, *
NAMTAB=120, *
NETID=NETC, *
NEWNAME=IFWC04, *
NPA=(YES,DRTP), *
NUMHSAS=8, *
OLT=NO, *
PWROFF=YES, *
SALIMIT=511, *
SESSACC=(YES,ALL,0,10000,1000,0,99,200,500,600,750,900), *
SLODOWN=12, *
SUBAREA=04, *
TRACE=(YES,100), *
TRANSFR=200, *
TYPGEN=NCP, *
TYP SYS=MVS, *
USGTIER=3, *
VERSION=V7R3, *
VRPOOL=254
```

Figure A-7 (Part 2 of 12). NCP C04 Sample Generation Definition

## NCP C04 Sample Generation Definition

```

*****
*      DYNAMIC CONTROL FACILITIES USED BY VTAM      *
*****
*
      SYSCNTRL OPTIONS=(BACKUP,BHSASSC,ENDCALL,LNSTAT,MODE,NAKLIM,RC*
        NTRL,RCOND,RECMD,RIMM,SESINIT,SESSION,SSPAUSE,STORDSP,XM*
        TLMT)
*****
HOSTC01  HOST  BFRPAD=0,          VTAM BUFFER PAD REQUIREMENT (TSC) *
          MAXBFRU=100,          MINIMUM HOST BUFFER ALLOCATION      *
          SUBAREA=01,
          UNITSZ=256            SIZE OF DATA PORTION OF HOST BUFFER *
*****
*      PATH DEFINITIONS      *
*****
      PATH DESTSA=1,          *
          ER0=(1,1,5000,5000,5000,20000), *
          ER1=(31,1,5000,5000,5000,20000), *
          VR0=0, *
          VRPWS00=(1,3),VRPWS01=(1,3),VRPWS02=(1,3), *
          VR1=1, *
          VRPWS10=(3,9),VRPWS11=(3,9),VRPWS12=(3,9)
      PATH DESTSA=3,          *
          ER0=(31,1),ER1=(1,1), *
          VR0=1, *
          VRPWS00=(2,6),VRPWS01=(2,6),VRPWS02=(2,6), *
          VR1=0, *
          VRPWS10=(2,6),VRPWS11=(2,6),VRPWS12=(2,6)
      PATH DESTSA=31,          *
          ER0=(1,1),ER1=(31,1), *
          VR0=1, *
          VRPWS00=(1,3),VRPWS01=(1,3),VRPWS02=(1,3), *
          VR1=0, *
          VRPWS10=(3,9),VRPWS11=(3,9),VRPWS12=(3,9)

```

Figure A-7 (Part 3 of 12). NCP C04 Sample Generation Definition

## NCP C04 Sample Generation Definition

```
*****
**** SDLCST DEFINITIONS FOR SUBAREA LINK GROUPS ****
*****
*
*
S04PRI SDLCST MODE=PRI,GROUP=C04GPRI
S04SEC SDLCST MODE=SEC,GROUP=C04GSEC
*
*****
          PUDRPOOL NUMBER=1
          LUDRPOOL NUMTYP1=02,NUMTYP2=2,NUMILU=1
*****
*      NPM DEFINITIONS FOR THE NPA ( NETWORK PERFORMANCE ANALYZER ) LUS *
*****
G04NPAGP GROUP LNCTL=SDLC,NPARSC=YES,VIRTUAL=YES
***
C04NPAL LINE
C04NPPU PU
C04NPLU1 LU
C04NPLU2 LU
C04NPLU3 LU
C04NPLU4 LU
C04NPLU5 LU
C04NPLU6 LU
C04NPLU7 LU
C04NPLU8 LU
***
*****
*      SUBAREA LINK: SDLC FOR PRIMARY/SECONDARY STATION *
*****
*
C04GPRI GROUP ACTIVTO=60.0, *
          DIAL=NO, *
          LNCTL=SDLC, *
          MODE=PRI, *

```

Figure A-7 (Part 4 of 12). NCP C04 Sample Generation Definition

## NCP C04 Sample Generation Definition

```

REPLYTO=30,
TYPE=NCP
*
*
C04GSEC GROUP ACTIVTO=60.0,
DIAL=NO,
LNCTL=SDLC,
MODE=SEC,
TYPE=NCP
*
*****
* SDLC SUBAREA LINE - 9.6 KBPS LINK - TGN=1 - USE FOR LPDA TESTING *
* CONNECT TO IFWA03 LINE 000 & 032 *
*****
*
C04GINN1 GROUP ANS=CONT,
CLOCKNG=EXT,
DIAL=NO,
DUPLEX=FULL,
LPDATS=LPDA2,
LNCTL=SDLC,
MONLINK=NO,
NRZI=YES,
REPLYTO=3,
RETRIES=(30,1,3),
SDLCST=(S04PRI,S04SEC),
TGN=1
*****
* SDLC SUBAREA LINE - 9.6 KBPS LINK - TGN=1 - *
* CONNECT TO IFWA03 LINE 000 & 032 *
*****
C04S00 LINE ADDRESS=(000,FULL)
C04P00 PU PUTYPE=4,LPDA=ALLOW
*
*****
* SDLC SUBAREA LINE - TGN=1 - SUBAREA CONNECTION *
* CONNECT TO IFWA03 LINE 033 *
*****
*
C04GINN4 GROUP ANS=CONT,
CLOCKNG=EXT,
DIAL=NO,

```

Figure A-7 (Part 5 of 12). NCP C04 Sample Generation Definition

## NCP C04 Sample Generation Definition

```

          DUPLEX=FULL,
          LNCTL=SDLC,
          MONLINK=NO,
          NRZI=YES,
          REPLYTO=3,
          RETRIES=(30,1,3),
          SDLCST=(S04PRI,S04SEC),
          TGN=1
*****
* SUBAREA LINE ADDRESS=001 FULL DUPLEX- CONNECTION TO IFWA03 LINE 33 *
*****
C04S01  LINE ADDRESS=(001,FULL)
C04P01  PU PUTYPE=4
*
*****
* FRAME RELAY PHYSICAL GROUP - FULL DUPLEX
*****
C04FRGP1 GROUP FRELAY=PHYSICAL,
          ISTATUS=ACTIVE,
          TYPE=NCP,
          DIAL=NO,
          LNCTL=SDLC,
          NPACOLL=(YES,EXTENDED),
          PUTYPE=1
*
*****
* FRAME RELAY PHYSICAL LINE 16 - FULL DUPLEX 56 KB
* - CONNECTION TO IFWB75 LINE 048
*****
C04F16  LINE ADDRESS=(016,FULL),
          MAXFRAME=2106,
          CLOCKNG=EXT,
          NRZI=NO,
          SPEED=56000
C04P16  PU LMI=ANSI,
          SPOLL=6,
          ERRORT=(3,4),
          TIMERS=(10,15),
          PUDR=NO,
          NPACOLL=(YES,EXTENDED),
          INNPORT=YES,
          ANS=CONTINUE
*

```

Figure A-7 (Part 6 of 12). NCP C04 Sample Generation Definition

## NCP C04 Sample Generation Definition

```

C04P16A  PU DLCI=(80,D),
          NPACOLL=(YES,EXTENDED),
          INNPOR=YES,
          ANS=CONTINUE
*
C04P16B  PU DLCI=(81,D),
          NPACOLL=(YES,EXTENDED),
          INNPOR=YES,
          ANS=CONTINUE
*
C04P16C  PU DLCI=(96,D),
          NPACOLL=(YES,EXTENDED),
          INNPOR=YES,
          ANS=CONTINUE
*
* FRSE PU TO BE ADDED USING VTAM 4.1 PERM DR
*C04P16D  PU  ADDR=52
*
*****
* FRAME RELAY PHYSICAL LINE 1028 - FULL DUPLEX HPTSS
*                               - CONNECTION TO IFWB31 LINE 1036
*****
C04F1028 LINE ADDRESS=(1028,FULL),
          MAXFRAME=2106,
          CLOCKNG=EXT,
          NRZI=NO,
          SPEED=1544000
C04P1028 PU LMI=CCITT,
          SPOLL=6,
          ERRORT=(3,4),
          TIMERS=(10,15),
          PUDR=NO,
          NPACOLL=(YES,EXTENDED),
          INNPOR=YES,
          ANS=CONTINUE
*
C04P28A  PU DLCI=(31,D),
          NPACOLL=(YES,EXTENDED),
          INNPOR=YES,
          ANS=CONTINUE
*

```

Figure A-7 (Part 7 of 12). NCP C04 Sample Generation Definition

## NCP C04 Sample Generation Definition

```

C04P28B  PU DLCI=(47,D),
          NPACOLL=(YES,EXTENDED),
          INNPORT=YES,
          ANS=CONTINUE
*
C04P28C  PU DLCI=(80,D),
          NPACOLL=(YES,EXTENDED),
          INNPORT=YES,
          ANS=CONTINUE
*
* FRSE PU TO BE ADDED USING VTAM 4.1 PERM DR
*C04P28D PU  ADDR=3F
*
*****
* FRAME RELAY PHYSICAL PERIPHERAL GROUP - FULL DUPLEX
*****
C04FRGP2 GROUP FRELAY=(PHY,PER),
              ISTATUS=ACTIVE,
              TYPE=NCP,
              DIAL=NO,
              LNCTL=SDLC,
              NPACOLL=(YES,EXTENDED),
              PUTYPE=1
*
*****
* FRAME RELAY PHYSICAL LINE 20 - FULL DUPLEX 56 KB
*                               - BAN CONNECTION TO 6611 OR 2210
*****
C04F20  LINE ADDRESS=(020,FULL),
          MAXFRAME=2106,
          LOCADD=4FFF00000000,
          CLOCKNG=EXT,
          NRZI=NO,
          SPEED=56000
C04P20  PU LMI=ANSI,
          SPOLL=6,
          ERRORT=(3,4),
          TIMERS=(10,15),
          PUDR=NO,
          NPACOLL=(YES,EXTENDED),
          INNPORT=YES,
          ANS=CONTINUE
*

```

Figure A-7 (Part 8 of 12). NCP C04 Sample Generation Definition



## NCP C04 Sample Generation Definition

```

*****
* FRAME RELAY LOGICAL BNN LINES - PHYSRSC=C04P20 *
*****
C04FRBG1 GROUP FRELAY=(LOGICAL,PER), X
          ANS=CONTINUE, X
          AUTOGEN=10, X
          CALL=INOUT, X
          MODETAB=AMODETAB, X
          ISTATUS=ACTIVE, X
          LOCALTO=6, X
          PHYSRSC=C04P20, X
          USSTAB=AMODETAB, X
          RETRIES=(10,0,0), X
          XID=YES, X
          DYNPU=YES, X
          DYNPUFX=DF, X
          XMITDLY=NONE X
*****
* NCP TOKEN-RING INTERCONNECT PHYSICAL LINES *
*****
*
C04NTRP1 GROUP ECLTYPE=(PHYSICAL,ANY), *
          ANS=CONTINUE, *
          RETRIES=(20,5,5), *
          USSTAB=AUSSTAB, *
          XID=NO, *
          TYPE=NCP, *
          DIAL=NO, *
          LNCTL=SDLC, *
          LEVEL2=ECLNARL2, *
          LEVEL3=ECLNARL3, *
          LEVEL5=NCP, *
          TIMER=(ECLNART1,,ECLNART2,ECLNART3), *
          XIO=(ECLNARXL,ECLNARXS,ECLNARXI,ECLNARXK), *
          USERID=(5668854,ECLRBDT,NORECMS,,ECLNMVT), *
          SPEED=9600, *
          NPACOLL=NO, *
          PUTYPE=1, *
          PUDR=NO, *
          COMPTAD=YES, *
          COMPSWP=YES, *
          COMPOWN=YES

```

Figure A-7 (Part 9 of 12). NCP C04 Sample Generation Definition

## NCP C04 Sample Generation Definition

```
*****
* ADDRESS 1088: NTRI PHYSICAL LINE - SUBAREA/PERIPHERAL *
*****
*
C04TR88 LINE ADDRESS=(1088,FULL), *
          ADAPTER=TIC2, *
          LOCADD=4000000C0431, *
          PORTADD=1, *
          MAXFRAME=2106, *
          TRSPEED=4, *
          UACB=(X$P1AX,X$P1AR)
*
C04PU88 PU ADDR=01, *
          INNPORT=YES
*
C04PU88B PU NETWORK=FRELAY,COMRATE=(,3),PUTYPE=1,ADDR=03
*
*****
* NTRI PERIPHERAL LOGICAL CONNECTIONS FOR 1088 *
*****
*
C04NTRL1 GROUP ECLTYPE=LOGICAL, *
               ANS=CONTINUE, *
               AUTOGEN=50, *
               CALL=INOUT, *
               MODETAB=AMODETAB, *
               PHYPORT=NONE, *
               PHYSRSC=NONE, *
               NPACOLL=(YES,EXTENDED), *
               RETRIES=(10,4,10,6), *
               RNRLIMT=3, *
               USSTAB=AUSSTAB, *
               XMITDLY=NONE, *
               TYPE=NCP, *
               DIAL=YES, *
               LNCTL=SDLC, *
               LEVEL2=ECLNAVL2, *
               LEVEL3=ECLNAVL3, *
               LEVEL5=NCP, *
               XIO=(ECLNAVXL,ECLNAVXS,ECLNAVXI,ECLNAVXK), *
               USERID=(5668854,ECLVBDT,NORECMS,,ECLNMVT), *
```

Figure A-7 (Part 10 of 12). NCP C04 Sample Generation Definition

## NCP C04 Sample Generation Definition

```

LINEADD=NONE, *
LINEAUT=YES, *
PUTYPE=2, *
COMPOWN=YES
*
*****
* LOGICAL DEFINITIONS FOR FRAME RELAY PORT C04PU88B *
*****
*
C04FRTG1 GROUP ECLTYPE=(LOGICAL,FRELAY),PUTYPE=1,TYPE=NCP,DIAL=NO, X
LNCTL=SDLC,LINEADD=NONE,COMPOWN=YES,RETRIES=(6,0,0,6), X
PHYSRSC=C04PU88B
C04LFR3A LINE MAXFRAME=2106,NPACOLL=(YES,EXTENDED),MAXPU=240, X
COMRATE=(,1)
C04LM88A PU LMI=ANSI,ANS=CONT,ADDR=C4400000007531
*
C04P88A PU DLCI=(96,D), *
NPACOLL=(YES,EXTENDED), *
INNPORT=YES, *
ANS=CONTINUE
*
C04P88B PU DLCI=(97,D), *
NPACOLL=(YES,EXTENDED), *
INNPORT=YES, *
ANS=CONTINUE
*
*
* FRSE PU TO BE ADDED USING VTAM 4.1 PERM DR
*C04P88D PU ADDR=62
*
*****
* FRSESET DEFINITIONS *
*****
PVCSET1 FRSESET SUBPORTS=(C04P28A,C04P88A,,C04P16A)
PVCSET2 FRSESET SUBPORTS=(C04P28B,C04P88B,,C04P16B)
PVCSET3 FRSESET SUBPORTS=(C04P28C,C04P16C)
* FRSESET TO BE ADDED USING VTAM 4.1 PERM DR
*PVCSET4 FRSESET SUBPORTS=(C04P28D,C04P88D,,C04P16D)

```

Figure A-7 (Part 11 of 12). NCP C04 Sample Generation Definition

## NCP C04 Sample Generation Definition

```
*
*****
* CHANNEL ADAPTERS - CODED TYPE 7 WILL TAKE ADVANTAGE OF BCCA IF   *
*                   INSTALLED. WILL ACT AS TYPE 6 IF CA IS CADS.   *
*                                                                     *
*****
***
C04CAG1  GROUP LNCTL=CA,                                           *
          CA=TYPE7,                                               *
          NCPCA=ACTIVE,                                           *
          TRANSFR=200,                                           *
          TIMEOUT=480.0,                                         *
          ISTATUS=ACTIVE,                                         *
          NPACOLL=YES
*
*****
* PHYSICAL PORTS 5 & 6 -- TG=1 -- CONNECT TO HOST C01N           *
*****
C04CP5   LINE ADDRESS=P5,                                         *
          CASDL=420,                                             *
          DELAY=0.2
*
C04P05A  PU PUTYPE=5,                                           *
          TGN=1
*
*
C04CP6   LINE ADDRESS=P6,                                         *
          CASDL=420,                                             *
          DELAY=0.2
*
*
C04P06A  PU PUTYPE=5,                                           *
          TGN=1
*
*
GENEND   GENEND
```

Figure A-7 (Part 12 of 12). NCP C04 Sample Generation Definition

## Appendix B. SSP Generated Inputs to NETDA/2

This section describes the ability of SSP V4R3 or later to support automated data entry for Network Design and Analysis/2 (NETDA/2) V1R3 or later. When using IBM's NETDA/2 program, you can automate part of the data entry task by using SSP to generate tables. These tables can be given to NETDA/2 as input. They can be used to add links or update topology characteristics of the links and NCPs in NETDA/2's network input object. See the *NETDA/2 User's Guide* (SC31-6440) for more information about inputting the tables to NETDA/2.

Use SSP's IFWNET CLIST along with NetView, to generate a table that contains details of all links connected to all NCPs owned by a single VTAM. The table specifies:

1. Two ends of the link
2. Two PU names at each end of the link
3. NETID of the link
4. Link name at one end of the link

Use IFWNET to generate a table for each VTAM in your network, and supply each table as an input to NETDA/2. The following is an example of what an IFWNET-generated table looks like. It was generated by running IFWNET on Host A17 of the sample network in Appendix A. The ADJLNKSTA column is generated only by VTAM V4R3 or later.

```
*****
**** ABBREVIATED IFWA03 - NCP FOR SAMPLES NETWORK SUBAREA 03 ****
DISPLAY STATION LOG
  NODE   LINK   LNKSTA STATUS ---ADJNODE ADJSA NETID  ADJLNKSTA
A17NPU  0012-L  0012-S  ACTIV ---A03710A   3   NETA
A17NPU  CTCLINE4 CTCPU4  ACTIV ---          500  NETA
A17NPU  CTCLINE5 CTCPU5  ACTIV ---          500  NETA
A03710A A03S03  A03P03A NEVAC ---
A03710A A03S04  A03P04A NEVAC ---
A03710A A03S00  A03P00  NEVAC ---
A03710A A03S32  A03P32  ACTIV ---C04620   4   NETC  C04620PA
A03710A A03S33  A03P33  ACTIV ---C04620   4   NETC  C04620PL
A03710A A03S16  A03P16  ACTIV ---B31710A  31  NETB  B317P03
A03710A A03S48  A03P48  NEVAC ---
A03710A A03LL1G A03PL1G NEVAC ---
A03710A A03LG1A A03PG1A ACTIV ---B31710A   3   NETC  B317PL1B
A03710A A03CP1  A03PP1A NEVAC ---
A03710A A03CP7  A03PP7A NEVAC ---
```

Figure B-1. Host A17 Sample IFWNET Generated Table

For more information about the IFWNET CLIST, see the *NCP/SSP Diagnosis Guide*.

Code the NDF NETDA2 parameter on your NCP generation to build a table for each NCP in your network, and supply each table as an input to NETDA/2. The table contains the following data concerning the NCP and its links:

1. Set of owners of the NCP
2. NETID of the NCP
3. SALIMIT of the NCP
4. SA number of the NCP

## SSP Generated Inputs to NETDA/2

5. Path statements
6. Link data including the following elements:
  - a. PU name at the NCP
  - b. Physical address at the NCP
  - c. Line Placement at the NCP
  - d. MLTG priority at the NCP
  - e. Line speed, duplex, line type (channel/switched/SDLC/etc.), TG number

For more information about coding the NETDA2 parameter, refer to the *NCP, SSP, and EP Generation and Loading Guide*. The following is an example of what an NDF-generated table looks like. It was obtained from the generation of NCP A03 of the sample network in Appendix A.

```
*****
***** ABBREVIATED IFWA03 - NCP FOR SAMPLES NETWORK SUBAREA 03 *****
ESD          $NETDA2
             OPTIONS NEWDEFN=YES
APCCU1      PCCU NETID=NETA,          *
             OWNER=A500N,            *
             SUBAREA=500,             *
             TGN=ANY,                 *
             MAXDATA=4096
APCCU2      PCCU NETID=NETA,          *
             OWNER=A17N,             *
             SUBAREA=17,              *
             MAXDATA=4096
APCCU4      PCCU NETID=NETB,          *
             OWNER=B01N,             *
             SUBAREA=01,              *
             MAXDATA=4096
IFWA03      BUILD VERSION=V7R3,      *
             MLTGORDR=FIFO,          *
             NETID=NETA,              *
             SALIMIT=1023,           *
             SUBAREA=3,               *
             TYPGEN=NCP,              *
```

Figure B-2 (Part 1 of 14). NCP A03 Sample NDF-Generated Table

```

USGTIER=5, *
MODEL=3745-210
SYSCNTRL OPTIONS=(BACKUP,BHSASSC,DLRID,DVSINIT,ENDCALL,LNSTAT,*
MODE,NAKLIM,RCNTRL,RCOND,RDEVQ,RECMD,RIMM,SESINIT,SESSIO*
N,SSPAUSE,STORDSP,XMTLMT)
PATH ER0=(4,1,5000,5000,5000,20000), *
ER1=(4,1), *
ER2=(4,1), *
ER3=(4,1), *
ER4=(4,1), *
ER5=(4,1), *
ER6=(4,1), *
ER7=(4,1), *
VR0=0, *
VRPWS00=(1,3), *
VRPWS01=(1,3), *
VRPWS02=(1,3), *
VR1=1, *
VRPWS10=(2,6), *
VRPWS11=(2,6), *
VRPWS12=(2,6), *
VR2=2, *
VRPWS20=(3,9), *
VRPWS21=(3,9), *
VRPWS22=(3,9), *
VR3=3, *
VRPWS30=(3,9), *
VRPWS31=(3,9), *
VRPWS32=(3,9), *
VR4=4, *
VRPWS40=(3,9), *
VRPWS41=(3,9), *
VRPWS42=(3,9), *
VR5=5, *
VRPWS50=(3,9), *
VRPWS51=(3,9), *
VRPWS52=(3,9), *
VR6=6, *
VRPWS60=(3,9), *
VRPWS61=(3,9), *
VRPWS62=(3,9), *
VR7=7, *
VRPWS70=(3,9), *
VRPWS71=(3,9), *
VRPWS72=(3,9), *
DESTSA=(1,2,4,81,31)

```

Figure B-2 (Part 2 of 14). NCP A03 Sample NDF-Generated Table

## SSP Generated Inputs to NETDA/2

```

PATH ER0=(17,1,5000,5000,5000,20000),
ER1=(17,1),
ER2=(17,1),
ER3=(17,1),
ER4=(17,1),
ER5=(17,1),
ER6=(17,1),
ER7=(17,1),
VR0=0,
VRPWS00=(1,3),
VRPWS01=(1,3),
VRPWS02=(1,3),
VR1=1,
VRPWS10=(2,6),
VRPWS11=(2,6),
VRPWS12=(2,6),
VR2=2,
VRPWS20=(3,9),
VRPWS21=(3,9),
VRPWS22=(3,9),
VR3=3,
VRPWS30=(3,9),
VRPWS31=(3,9),
VRPWS32=(3,9),
VR4=4,
VRPWS40=(3,9),
VRPWS41=(3,9),
VRPWS42=(3,9),
VR5=5,
VRPWS50=(3,9),
VRPWS51=(3,9),
VRPWS52=(3,9),
VR6=6,
VRPWS60=(3,9),
VRPWS61=(3,9),
VRPWS62=(3,9),
VR7=7,
VRPWS70=(3,9),
VRPWS71=(3,9),
VRPWS72=(3,9),
DESTSA=17
PATH ER0=(500,1,5000,5000,5000,20000),
ER1=(500,2,5000,5000,5000,20000),
ER2=(17,1),
ER3=(17,1),

```

Figure B-2 (Part 3 of 14). NCP A03 Sample NDF-Generated Table



```

ER4=(500,1), *
ER5=(500,1), *
ER6=(500,1), *
ER7=(500,1), *
VR0=0, *
VRPWS00=(1,3), *
VRPWS01=(1,3), *
VRPWS02=(1,3), *
VR1=1, *
VRPWS10=(2,6), *
VRPWS11=(2,6), *
VRPWS12=(2,6), *
VR2=2, *
VRPWS20=(3,9), *
VRPWS21=(3,9), *
VRPWS22=(3,9), *
VR3=3, *
VRPWS30=(3,9), *
VRPWS31=(3,9), *
VRPWS32=(3,9), *
VR4=4, *
VRPWS40=(3,9), *
VRPWS41=(3,9), *
VRPWS42=(3,9), *
VR5=5, *
VRPWS50=(3,9), *
VRPWS51=(3,9), *
VRPWS52=(3,9), *
VR6=6, *
VRPWS60=(3,9), *
VRPWS61=(3,9), *
VRPWS62=(3,9), *
VR7=7, *
VRPWS70=(3,9), *
VRPWS71=(3,9), *
VRPWS72=(3,9), *
DESTSA=500
S03PRI SDLCST MODE=PRIMARY, *
        GROUP=A03GPRI
S03SEC SDLCST MODE=SECONDARY, *
        GROUP=A03GSEC
        PUDRPOOL NUMBER=10
        LUDRPOOL NUMILU=150, *
        NUMTYP1=5, *
        NUMTYP2=150
*****
*01 STANDALONE SDLC GROUPS
*****
A03GPRI GROUP DIAL=NO, *
        MODE=PRI, *
        LNCTL=SDLC
A03GSEC GROUP DIAL=NO, *
        MODE=SEC, *
        LNCTL=SDLC

```

Figure B-2 (Part 4 of 14). NCP A03 Sample NDF-Generated Table

## SSP Generated Inputs to NETDA/2

```

*****
*02 MULTIPOINT SUBAREA AND PERIPHERAL SDLC LINES
*****
A03GMUL1 GROUP DIAL=NO,
                MODE=SEC,
                LNCTL=SDLC
A03S03  LINE SPEED=2400,
                TADDR=02,
                ADDRESS=(3,FULL)
                SERVICE ORDER=A03P03A
A03P03A  PU TGCONF=(MULTI,NORMAL),
                TGN=1,
                PUTYPE=4
A03S04  LINE SPEED=2400,
                TADDR=03,
                ADDRESS=(4,FULL)
                SERVICE ORDER=A03P04A
A03P04A  PU TGCONF=(MULTI,NORMAL),
                TGN=1,
                PUTYPE=4
*****
*03 POINT TO POINT SDLC SUBAREA LINES
*****
A03LEAS1 GROUP DIAL=NO,
                LNCTL=SDLC
A03S00  LINE SDLCST=(S03PRI,S03SEC),
                SPEED=9600,
                ADDRESS=(0,FULL)
A03P00  PU TGCONF=(MULTI,NORMAL),
                TGN=1,
                PUTYPE=4
A03S32  LINE SDLCST=(S03PRI,S03SEC),
                SPEED=9600,
                ADDRESS=(32,FULL)
A03P32  PU TGCONF=(MULTI,NORMAL),
                TGN=1,
                PUTYPE=4
A03S33  LINE SDLCST=(S03PRI,S03SEC),
                SPEED=9600,
                ADDRESS=(33,FULL)
A03P33  PU TGCONF=(MULTI,NORMAL),
                TGN=1,
                PUTYPE=4
A03S16  LINE SDLCST=(S03PRI,S03SEC),
                SPEED=56000,
                ADDRESS=(16,FULL)
A03P16  PU TGCONF=(MULTI,NORMAL),
                TGN=1,
                PUTYPE=4
A03S48  LINE SDLCST=(S03PRI,S03SEC),
                SPEED=56000,
                ADDRESS=(48,FULL)
A03P48  PU TGCONF=(MULTI,NORMAL),
                TGN=1,
                PUTYPE=4

```

Figure B-2 (Part 5 of 14). NCP A03 Sample NDF-Generated Table

```

A03S128 LINE SDLCST=(S03PRI,S03SEC),
          SPEED=1544000,
          ADDRESS=(1028,FULL)
A03P128 PU TGCONF=(MULTI,NORMAL),
          TGN=1,
          PUTYPE=4
*****
*05 MULTIPOINT SDLC PERIPHERAL LINES
*****
A03BNN1 GROUP DIAL=NO,
          LNCTL=SDLC
A03S34 LINE SPEED=9600,
          ADDRESS=(34,FULL)
A03P34A PU ADDR=C1,
          PUTYPE=2
A03S35 LINE SPEED=9600,
          ADDRESS=(35,FULL)
A03P35A PU ADDR=C1,
          PUTYPE=2
A03S20 LINE SPEED=56000,
          ADDRESS=(20,FULL)
A03P20A PU ADDR=C1,
          PUTYPE=2
A03P20B PU ADDR=C2,
          PUTYPE=2
A03P20C PU ADDR=C3,
          PUTYPE=2
A03BNN1 GROUP DIAL=NO,
          LNCTL=SDLC
A03S01 LINE SPEED=9600,
          ADDRESS=(1,FULL)
A03P01A PU ADDR=C1,
          PUTYPE=2
A03P01B PU ADDR=C2,
          PUTYPE=2
*****
*14 TOKEN RING PHYSICAL LINES
*****
A03NTR1 GROUP DIAL=NO,
          ECLTYPE=(PHYSICAL,ANY),
          LNCTL=SDLC
A03TR88 LINE LOCADD=400000000331,
          PORTADD=1,
          ADAPTER=TIC2,
          TRSPEED=16,
          ADDRESS=(1088,FULL)
A03PU88 PU ADDR=01,
          COMRATE=(,1),
          NETWORK=SNA,
          PUTYPE=1
A03NTR2 GROUP DIAL=NO,
          ECLTYPE=(PHYSICAL,PERIPHERAL),
          LNCTL=SDLC
A03TR89 LINE LOCADD=400000FEDCBA,
          PORTADD=2,

```

Figure B-2 (Part 6 of 14). NCP A03 Sample NDF-Generated Table

## SSP Generated Inputs to NETDA/2

```

ADAPTER=TIC2,
TRSPPEED=16,
ADDRESS=(1089,FULL)
A03PU89 PU ADDR=01,
COMRATE=(,1),
PUTYPE=1
A03TR92 LINE LOCADD=400000ABCDEF,
PORTADD=5,
ADAPTER=TIC2,
TRSPPEED=16,
ADDRESS=(1092,FULL)
A03PU92 PU ADDR=01,
COMRATE=(,1),
PUTYPE=1
A03TR93 LINE LOCADD=400000ABCDEF,
PORTADD=6,
ADAPTER=TIC2,
TRSPPEED=4,
ADDRESS=(1093,FULL)
A03PU93 PU ADDR=01,
COMRATE=(,1),
PUTYPE=1
*****
*15 TOKEN RING LOGICAL SUBAREA LINES
*****
A03NTRL3 GROUP DIAL=NO,
ECLTYPE=(LOGICAL,SUBAREA),
PHYSRSC=A03PU88,
PHYPORT=1,
LNCTL=SDLC
A03LG1A LINE SDLCST=(S03PRI,S03SEC),
ADDRESS=NONE
A03PG1A PU TGCONF=(MULTI,NORMAL),
TGN=1,
ADDR=04400000017335,
PUTYPE=4
*****
*16 TOKEN RING LOGICAL PERIPHERAL LINES
*****
A03NTRL1 GROUP DIAL=YES,
ECLTYPE=(LOGICAL,PERIPHERAL),
PHYSRSC=NONE,
PHYPORT=NONE,
LNCTL=SDLC
J0003001 LINE ADDRESS=NONE
J0003002 PU PUTYPE=2

```

Figure B-2 (Part 7 of 14). NCP A03 Sample NDF-Generated Table

J0003003 LINE ADDRESS=NONE  
J0003004 PU PUTYPE=2  
J0003005 LINE ADDRESS=NONE  
J0003006 PU PUTYPE=2  
J0003007 LINE ADDRESS=NONE  
J0003008 PU PUTYPE=2  
J0003009 LINE ADDRESS=NONE  
J000300A PU PUTYPE=2  
J000300B LINE ADDRESS=NONE  
J000300C PU PUTYPE=2  
J000300D LINE ADDRESS=NONE  
J000300E PU PUTYPE=2  
J000300F LINE ADDRESS=NONE  
J0003010 PU PUTYPE=2  
J0003011 LINE ADDRESS=NONE  
J0003012 PU PUTYPE=2  
J0003013 LINE ADDRESS=NONE  
J0003014 PU PUTYPE=2  
J0003015 LINE ADDRESS=NONE  
J0003016 PU PUTYPE=2  
J0003017 LINE ADDRESS=NONE  
J0003018 PU PUTYPE=2  
J0003019 LINE ADDRESS=NONE  
J000301A PU PUTYPE=2  
J000301B LINE ADDRESS=NONE  
J000301C PU PUTYPE=2  
J000301D LINE ADDRESS=NONE  
J000301E PU PUTYPE=2  
J000301F LINE ADDRESS=NONE  
J0003020 PU PUTYPE=2  
J0003021 LINE ADDRESS=NONE  
J0003022 PU PUTYPE=2  
J0003023 LINE ADDRESS=NONE  
J0003024 PU PUTYPE=2  
J0003025 LINE ADDRESS=NONE  
J0003026 PU PUTYPE=2  
J0003027 LINE ADDRESS=NONE  
J0003028 PU PUTYPE=2  
J0003029 LINE ADDRESS=NONE  
J000302A PU PUTYPE=2  
J000302B LINE ADDRESS=NONE  
J000302C PU PUTYPE=2  
J000302D LINE ADDRESS=NONE  
J000302E PU PUTYPE=2  
J000302F LINE ADDRESS=NONE  
J0003030 PU PUTYPE=2  
J0003031 LINE ADDRESS=NONE  
J0003032 PU PUTYPE=2  
J0003033 LINE ADDRESS=NONE  
J0003034 PU PUTYPE=2  
J0003035 LINE ADDRESS=NONE  
J0003036 PU PUTYPE=2  
J0003037 LINE ADDRESS=NONE

Figure B-2 (Part 8 of 14). NCP A03 Sample NDF-Generated Table

## SSP Generated Inputs to NETDA/2

```

J0003038 PU PUTYPE=2
J0003039 LINE ADDRESS=NONE
J000303A PU PUTYPE=2
J000303B LINE ADDRESS=NONE
J000303C PU PUTYPE=2
J000303D LINE ADDRESS=NONE
J000303E PU PUTYPE=2
J000303F LINE ADDRESS=NONE
J0003040 PU PUTYPE=2
J0003041 LINE ADDRESS=NONE
J0003042 PU PUTYPE=2
J0003043 LINE ADDRESS=NONE
J0003044 PU PUTYPE=2
J0003045 LINE ADDRESS=NONE
J0003046 PU PUTYPE=2
J0003047 LINE ADDRESS=NONE
J0003048 PU PUTYPE=2
J0003049 LINE ADDRESS=NONE
J000304A PU PUTYPE=2
J000304B LINE ADDRESS=NONE
J000304C PU PUTYPE=2
J000304D LINE ADDRESS=NONE
J000304E PU PUTYPE=2
J000304F LINE ADDRESS=NONE
J0003050 PU PUTYPE=2
J0003051 LINE ADDRESS=NONE
J0003052 PU PUTYPE=2
J0003053 LINE ADDRESS=NONE
J0003054 PU PUTYPE=2
J0003055 LINE ADDRESS=NONE
J0003056 PU PUTYPE=2
J0003057 LINE ADDRESS=NONE
J0003058 PU PUTYPE=2
J0003059 LINE ADDRESS=NONE
J000305A PU PUTYPE=2
J000305B LINE ADDRESS=NONE
J000305C PU PUTYPE=2
J000305D LINE ADDRESS=NONE
J000305E PU PUTYPE=2
J000305F LINE ADDRESS=NONE
J0003060 PU PUTYPE=2
J0003061 LINE ADDRESS=NONE
J0003062 PU PUTYPE=2
J0003063 LINE ADDRESS=NONE
J0003064 PU PUTYPE=2
*****
*21 FRAME RELAY PHYSICAL LINES AND FRAME HANDLER SUPPORTS
*****
A03FRGP2 GROUP DIAL=NO,
                LNCTL=SDLC,
                FRELAY=(PHYSICAL,SUBAREA)
A03F52  LINE SPEED=56000,
                MAXFRAME=2106,
                ADDRESS=(52,FULL)
                *
                *
                *
                *

```

Figure B-2 (Part 9 of 14). NCP A03 Sample NDF-Generated Table

```

A03P52  PU PUTYPE=1
A03FRGP1 GROUP DIAL=NO, *
                LNCTL=SDLC, *
                FRELAY=(PHYSICAL,ANY)
A03F1036 LINE SPEED=1544000, *
                LOCADD=4FFF00000000, *
                MAXFRAME=2106, *
                ADDRESS=(1036,FULL)
A03P1036 PU PUTYPE=1
*****
*22 FRAME RELAY LOGICAL SUBAREA LINES
*****
A03FRGL2 GROUP DIAL=NO, *
                PHYSRSC=A03P52, *
                LNCTL=SDLC, *
                FRELAY=(LOGICAL,SUBAREA)
A03LL1G LINE SDLCST=(S03PRI,S03SEC), *
                ADDRESS=NONE
A03PL1G PU TGCONF=(MULTI,NORMAL), *
                TGN=1, *
                DLCI=(D,), *
                COMRATE=(,1), *
                PUTYPE=4
A03FRGL1 GROUP DIAL=NO, *
                PHYSRSC=A03P1036, *
                LNCTL=SDLC, *
                FRELAY=(LOGICAL,SUBAREA)
A03LL1A LINE SDLCST=(S03PRI,S03SEC), *
                ADDRESS=NONE
A03PL1A PU TGCONF=(MULTI,NORMAL), *
                TGN=1, *
                DLCI=(D,), *
                COMRATE=(,1), *
                PUTYPE=4
A03LL1B LINE SDLCST=(S03PRI,S03SEC), *
                ADDRESS=NONE
A03PL1B PU TGCONF=(MULTI,NORMAL), *
                TGN=1, *
                DLCI=(D,), *
                COMRATE=(,1), *
                PUTYPE=4
A03LL1C LINE SDLCST=(S03PRI,S03SEC), *
                ADDRESS=NONE
A03PL1C PU TGCONF=(MULTI,NORMAL), *
                TGN=1, *
                DLCI=(D,), *
                COMRATE=(,1), *
                PUTYPE=4
*****
*29 OEMI CHANNEL CONNECTIONS
*****
A03CA1  GROUP LNCTL=CA
A03CP1  LINE ADDRESS=P1
A03PP1A PU TGN=1, *
                PUTYPE=5

```

Figure B-2 (Part 10 of 14). NCP A03 Sample NDF-Generated Table

## SSP Generated Inputs to NETDA/2

```

A03CP3  LINE ADDRESS=P3
A03PP3A PU PUTYPE=2
A03CP5  LINE ADDRESS=P5
A03PP5A PU PUTYPE=2
A03CP7  LINE ADDRESS=P7
A03PP7A PU TGN=1, *
          PUTYPE=5
NETB    NETWORK NETID=NETB, *
          SALIMIT=2047, *
          SUBAREA=3
PATH    ER0=(1,1,5000,5000,5000,20000), *
          ER1=(31,1,5000,5000,5000,20000), *
          ER2=(1,1), *
          ER3=(31,1), *
          ER4=(1,1), *
          ER5=(31,1), *
          ER6=(1,1), *
          ER7=(31,1), *
          VR0=0, *
          VRPWS00=(1,3), *
          VRPWS01=(1,3), *
          VRPWS02=(1,3), *
          VR1=1, *
          VRPWS10=(2,6), *
          VRPWS11=(2,6), *
          VRPWS12=(2,6), *
          VR2=2, *
          VRPWS20=(2,6), *
          VRPWS21=(2,6), *
          VRPWS22=(2,6), *
          VR3=3, *
          VRPWS30=(2,6), *
          VRPWS31=(2,6), *
          VRPWS32=(2,6), *
          VR4=4, *
          VRPWS40=(3,9), *
          VRPWS41=(3,9), *
          VRPWS42=(3,9), *
          VR5=5, *
          VRPWS50=(3,9), *
          VRPWS51=(3,9), *
          VRPWS52=(3,9), *
          VR6=6, *
          VRPWS60=(3,9), *
          VRPWS61=(3,9), *
          VRPWS62=(3,9), *
          VR7=7, *
          VRPWS70=(3,9), *
          VRPWS71=(3,9), *
          VRPWS72=(3,9), *
          DESTSA=1

```

Figure B-2 (Part 11 of 14). NCP A03 Sample NDF-Generated Table



```

PATH ER0=(31,1), *
      ER1=(31,1), *
      ER2=(31,1), *
      ER3=(31,1), *
      ER4=(31,1), *
      ER5=(31,1), *
      ER6=(31,1), *
      ER7=(31,1), *
      VR0=0, *
      VRPWS00=(1,3), *
      VRPWS01=(1,3), *
      VRPWS02=(1,3), *
      VR1=1, *
      VRPWS10=(2,6), *
      VRPWS11=(2,6), *
      VRPWS12=(2,6), *
      VR2=2, *
      VRPWS20=(2,6), *
      VRPWS21=(2,6), *
      VRPWS22=(2,6), *
      VR3=3, *
      VRPWS30=(2,6), *
      VRPWS31=(2,6), *
      VRPWS32=(2,6), *
      VR4=4, *
      VRPWS40=(3,9), *
      VRPWS41=(3,9), *
      VRPWS42=(3,9), *
      VR5=5, *
      VRPWS50=(3,9), *
      VRPWS51=(3,9), *
      VRPWS52=(3,9), *
      VR6=6, *
      VRPWS60=(3,9), *
      VRPWS61=(3,9), *
      VRPWS62=(3,9), *
      VR7=7, *
      VRPWS70=(3,9), *
      VRPWS71=(3,9), *
      VRPWS72=(3,9), *
      DESTSA=31
PATH ER0=(31,1), *
      ER1=(31,1), *
      ER2=(31,1), *
      ER3=(31,1), *
      ER4=(31,1), *
      ER5=(31,1), *
      ER6=(31,1), *
      ER7=(31,1), *

```

Figure B-2 (Part 12 of 14). NCP A03 Sample NDF-Generated Table

## SSP Generated Inputs to NETDA/2

```

VR0=0, *
VRPWS00=(1,3), *
VRPWS01=(1,3), *
VRPWS02=(1,3), *
VR1=1, *
VRPWS10=(2,6), *
VRPWS11=(2,6), *
VRPWS12=(2,6), *
VR2=2, *
VRPWS20=(2,6), *
VRPWS21=(2,6), *
VRPWS22=(2,6), *
VR3=3, *
VRPWS30=(2,6), *
VRPWS31=(2,6), *
VRPWS32=(2,6), *
VR4=4, *
VRPWS40=(3,9), *
VRPWS41=(3,9), *
VRPWS42=(3,9), *
VR5=5, *
VRPWS50=(3,9), *
VRPWS51=(3,9), *
VRPWS52=(3,9), *
VR6=6, *
VRPWS60=(3,9), *
VRPWS61=(3,9), *
VRPWS62=(3,9), *
VR7=7, *
VRPWS70=(3,9), *
VRPWS71=(3,9), *
VRPWS72=(3,9), *
DESTSA=(75,1028) *
PATH ER0=(4,1,5000,5000,5000,20000), *
ER1=(3,1,5000,5000,5000,20000), *
VR0=1, *
VRPWS00=(2,6), *
VRPWS01=(2,6), *
VRPWS02=(2,6), *
VR1=0, *
VRPWS10=(2,6), *
VRPWS11=(2,6), *
VRPWS12=(2,6), *
DESTSA=1 *
PATH ER0=(3,1), *
ER1=(4,1), *
VR0=0, *
VRPWS00=(1,3), *
VRPWS01=(1,3), *
VRPWS02=(1,3), *
VR1=1, *
VRPWS10=(3,9), *
VRPWS11=(3,9), *
VRPWS12=(3,9), *
DESTSA=3 *

```

Figure B-2 (Part 13 of 14). NCP A03 Sample NDF-Generated Table

```
PATH ER0=(4,1), *
      ER1=(3,1), *
      VR0=0, *
      VRPWS00=(1,3), *
      VRPWS01=(1,3), *
      VRPWS02=(1,3), *
      VR1=1, *
      VRPWS10=(3,9), *
      VRPWS11=(3,9), *
      VRPWS12=(3,9), *
      DESTSA=4
GENEND GENEND
```

Figure B-2 (Part 14 of 14). NCP A03 Sample NDF-Generated Table



---

## List of Abbreviations, Glossary, Bibliography, and Index

<b>List of Abbreviations</b> .....	X-3
<b>Glossary</b> .....	X-7
<b>Bibliography</b> .....	X-35
NCP, SSP, and EP Library .....	X-35
Other Networking Products' Libraries .....	X-36
Networking Library .....	X-36
NTuneMON Library .....	X-36
SNA Services Library (formerly VTAM Library) .....	X-36
NPSI Library .....	X-36
NetView Library .....	X-36
NPM Library .....	X-37
NTO Library .....	X-37
NRF Library .....	X-37
Related Publications .....	X-37
IBM 3745 Communication Controller Publications .....	X-37
IBM 3746 Model 900 and Model 950 Publications .....	X-38
MVS/ESA Publications .....	X-38
SNA Publications .....	X-38
TCAM Publications .....	X-38
TCP/IP Publications .....	X-38
<b>Index</b> .....	X-39



---

## List of Abbreviations

For meanings of (A), (E), (I), and (T), see “Glossary” on page X-7.

<b>ACB</b>	adapter control block	<b>CLLM</b>	Consolidated Link Layer Management
<b>ACR</b>	abandon-call-and-retry	<b>CLP</b>	communication line processor
<b>ACR</b>	accelerated carriage return	<b>CMC</b>	communication management configuration host node
<b>ACU</b>	automatic calling unit	<b>CMS</b>	conversations monitor system
<b>ALCI</b>	airline line control integration	<b>CNM</b>	communication network management
<b>ALS</b>	adjacent link station	<b>CP</b>	control point
<b>ANA</b>	assign network address	<b>CPS</b>	call progress signal
<b>ANR</b>	automatic network routing	<b>CR</b>	command reject
<b>ANS</b>	automatic network shutdown	<b>CRI</b>	call request with identification
<b>ANSI</b>	American National Standards Institute	<b>CRN</b>	call request with number
<b>APPN</b>	Advanced Peer-to-Peer Networking	<b>CSMA/CD</b>	Carrier sense multiple access with collision detection
<b>ARP</b>	Address Resolution Protocol	<b>CSS</b>	connectivity subsystem
<b>ASCII</b>	American Standard Code for Information Interchange	<b>DCE</b>	data circuit-terminating equipment
<b>BAN</b>	boundary access node	<b>DLC</b>	data link control
<b>BECN</b>	backward explicit congestion notification	<b>DLCI</b>	data link connection identifier
<b>BER</b>	(1) box event record (2) box error record	<b>DMPX</b>	data multiplex
<b>BF</b>	boundary function	<b>DR</b>	dynamic reconfiguration
<b>bps</b>	bits per second	<b>DRDS</b>	dynamic reconfiguration data set
<b>BSB</b>	boundary session control block	<b>DSAP</b>	destination service access point
<b>BSC</b>	binary synchronous communication	<b>DSE</b>	data switching equipment
<b>CA</b>	channel adapter	<b>DSR</b>	data set ready
<b>CBP</b>	controller bus processor	<b>DTE</b>	data terminating equipment (A)
<b>CBSP</b>	controller bus and service processor	<b>EIB</b>	error information block
<b>CBTRP</b>	control bus and Token-Ring processor	<b>EOB</b>	end of block
<b>CCM</b>	Controller Configuration and Management	<b>EOT</b>	end of transmission
<b>CCITT</b>	International Telegraph and Telephone Consultative Committee (obsolete, see <i>ITU-TS</i> ).	<b>EP</b>	Emulation Program
<b>CCLID</b>	called-calling-ID	<b>ER</b>	Explicit route
<b>CCU</b>	central control unit	<b>ESCON</b>	Enterprise Systems Connection
<b>CDROM</b>	cross-domain resource manager	<b>ESCP</b>	ESCON processor
<b>CD-ROM</b>	compact disk read-only memory	<b>ESS</b>	Ethernet-type subsystem, that is, Ethernet adapter
<b>CDRSC</b>	cross-domain resources	<b>FCS</b>	frame check sequence
<b>CDS</b>	configuration data set	<b>FHSP</b>	frame handler support
<b>CICS</b>	Customer Information Control System	<b>FIFO</b>	first in first out (A)
<b>CIR</b>	committed information rate	<b>FR</b>	frame relay
<b>CLA</b>	communication line adapter	<b>FRFH</b>	frame-relay frame handler
		<b>FRMR</b>	frame reject

## Abbreviations

<b>FRSE</b>	frame-relay switching equipment	<b>MMMLTG</b>	mixed-media multilink transmission group
<b>FRTE</b>	frame-relay terminating equipment	<b>MOSS</b>	maintenance and operator subsystem
<b>FVT</b>	function vector tables	<b>MOSS-E</b>	maintenance and operator subsystem extended
<b>HPR</b>	high performance routing	<b>MTA</b>	multiple terminal access
<b>HPTSS</b>	High Performance Transmission Subsystem	<b>MTU</b>	(1) maximum transfer unit (2) maximum transmission unit
<b>HSCB</b>	half-session control block	<b>MVS</b>	Multiple Virtual Storage
<b>HSS</b>	high-speed scanner	<b>NAU</b>	network addressable units
<b>I/O</b>	input/output	<b>NCP</b>	Network Control Program
<b>ICA</b>	integrated communication adapter	<b>NCST</b>	NCP connectionless SNA transport
<b>ICMP</b>	Internet Control Message Protocol	<b>NDF</b>	NCP/EP definition facility
<b>ID</b>	(1) identifier (2) identification	<b>NDM</b>	normal disconnect mode
<b>IEEE</b>	Institute of Electrical & Electronic Engineers	<b>NETID</b>	Network identifier
<b>InARP</b>	Inverse Address Resolution Protocol	<b>NN</b>	Network node
<b>IP</b>	Internet Protocol	<b>NMVT</b>	network management vector table
<b>IPL</b>	initial program load	<b>NNT</b>	network names table
<b>ISDN</b>	integrated services digital network	<b>NPA</b>	network performance analyzer
<b>ITB</b>	intermediate text block	<b>NPDA</b>	Network Problem Determination Application
<b>ITU-TS</b>	International Telecommunication Union – Telecommunication Standardization Sector	<b>NPM</b>	NetView Performance Monitor
<b>JCL</b>	job control language	<b>NPSI</b>	X.25 NCP Packet Switching Interface
<b>Kbps</b>	kilobits per second	<b>NR</b>	Negative response
<b>KVT</b>	keyboard vector table	<b>NRF</b>	Network Routing Facility
<b>LA</b>	line adapter	<b>NRZ</b>	non-return-to-reference recording (I) (A)
<b>LAN</b>	local area network	<b>NRZ-1</b>	non-return-to-zero change-on-ones recording (I) (A)
<b>LCST</b>	line control selection table	<b>NRZI</b>	non-return-to-zero (inverted) recording. Deprecated term for <i>non-return-to-zero change-on-ones recording (NRZ-1)</i> .
<b>LEN</b>	low-entry networking	<b>NSA</b>	(1) network session accounting (2) Nonsequenced acknowledgement
<b>LIC</b>	line interface coupler	<b>NSI</b>	Non-SNA interconnection
<b>LIVT</b>	link integrity verification tests	<b>NTA</b>	Network Traffic Analyzer
<b>LKP</b>	link IPL ports	<b>NTO</b>	Network Terminal Option
<b>LLC</b>	logical link control	<b>NTRI</b>	NCP/Token-Ring interconnection
<b>LMI</b>	local management interface	<b>NTT</b>	Nippon Telegraph and Telephone
<b>LOBQ</b>	link outbound queue	<b>NUA</b>	network user address
<b>LPDA</b>	link problem determination aid	<b>NVT</b>	network vector table
<b>LRC</b>	longitudinal redundancy check	<b>ODLC</b>	outboard data link control
<b>LU</b>	logical unit	<b>OS</b>	operating system
<b>LUCB</b>	logical unit control block	<b>PAD</b>	packet assembler/disassembler
<b>MAC</b>	medium access control	<b>PCID</b>	procedure correlation identifier
<b>Mb</b>	megabit	<b>PDF</b>	parallel data field
<b>Mbps</b>	one million bits per second		
<b>MB</b>	megabyte		
<b>MLTG</b>	multilink transmission group		



<b>PDS</b>	partitioned data set	<b>SSAP</b>	source service access point
<b>PEP</b>	partitioned emulation programming	<b>SSCP</b>	system services control point
<b>PIU</b>	path information unit	<b>SSP</b>	System Support Programs
<b>PLU</b>	primary logical unit	<b>SVC</b>	(1) supervisor call (2) switched virtual circuit
<b>PSW</b>	program status word	<b>TAP</b>	synonym for ACF/TAP
<b>PU</b>	physical unit	<b>TCAM</b>	Telecommunications Access Method. Synonymous with ACF/TCAM
<b>PVC</b>	permanent virtual circuit	<b>TCP</b>	Transmission Control Protocol
<b>RAS</b>	reliability, availability, and serviceability	<b>TCP/IP</b>	Transmission Control Protocol/Internet Protocol
<b>RECMS</b>	record maintenance statistics	<b>TESP</b>	terminating equipment support
<b>REQMS</b>	request for maintenance statistics	<b>TG</b>	transmission group
<b>REX</b>	route extension	<b>TGB</b>	transmission group control block
<b>RH</b>	Request/response header	<b>TGN</b>	transmission group number
<b>RIP</b>	Routing Information Protocol	<b>TIC</b>	Token-Ring interface coupler
<b>RIP-1</b>	Routing Information Protocol Version 1	<b>TPF</b>	Transaction Processing Facility
<b>RIP-2</b>	Routing Information Protocol Version 2	<b>TR</b>	Token Ring
<b>RNAA</b>	request network address assignment	<b>TRP</b>	Token-Ring processor
<b>RNR</b>	receive not ready	<b>TRSS</b>	Token-Ring subsystem
<b>ROM</b>	Read-only memory (A)	<b>TRT</b>	transit routing table
<b>RPQ</b>	request for price quotation	<b>TSCP</b>	telecommunication service console processor
<b>RR</b>	receive ready	<b>TSO</b>	Time Sharing Option
<b>RRT</b>	resource resolution table	<b>TSS</b>	transmission subsystem
<b>RTG</b>	Route Table Generator	<b>TTD</b>	temporary text delay
<b>RTP</b>	Rapid Transport Protocol	<b>TWX</b>	teletypewriter exchange service
<b>RTS</b>	request to send	<b>UACB</b>	user adapter control block
<b>RU</b>	request/response unit	<b>UDP</b>	User Datagram Protocol
<b>SAP</b>	service access point	<b>VLB</b>	virtual line block
<b>SCF</b>	secondary control field	<b>VM/ESA</b>	Virtual Machine/Enterprise Systems Architecture
<b>SDLC</b>	synchronous data link control	<b>VR</b>	virtual route
<b>SIT</b>	scanner interface trace	<b>VSE</b>	Virtual Storage Extended.
<b>SKVT</b>	statement and keyword vector table	<b>VSE/ESA</b>	Virtual Storage Extended/Enterprise System Architecture
<b>SLU</b>	secondary logical unit	<b>VTAM</b>	Virtual Telecommunications Access Method
<b>SMMF</b>	SSCP monitor mode function	<b>WAN</b>	wide area network
<b>SNA</b>	Systems Network Architecture	<b>WTTY</b>	World Trade Teletypewriter
<b>SNALINK</b>	SNA Network Link	<b>XA</b>	extended architecture
<b>SNBU</b>	switched network backup	<b>XI</b>	X.25 SNA Interconnection
<b>SNI</b>	SNA network interconnection	<b>XID</b>	exchange identification
<b>SNRM</b>	Set normal response mode	<b>XMIT</b>	transmit
<b>SOT</b>	service order table	<b>XRF</b>	extended recovery facility
<b>SPS</b>	service and power support		
<b>SRT</b>	symbol resolution table		
<b>SS</b>	start-stop		



---

# Glossary

This glossary includes terms and definitions from:

- The *IBM Dictionary of Computing* (New York; McGraw–Hill, Inc., 1994)
- The *American National Standard Dictionary for Information Systems*, ANSI X3.172-1990, copyright 1990 by the American National Standards Institute (ANSI). Copies may be purchased from the American National Standards Institute, 11 West 42nd Street, New York, New York 10036. Definitions are identified by the symbol (A) after the definition.
- The ANSI/EIA Standard—440-A, *Fiber Optic Terminology*. Copies may be purchased from the Electronic Industries Association, 2001 Pennsylvania Avenue, N.W., Washington, DC 20006. Definitions are identified by the symbol (E) after the definition.
- The *Information Technology Vocabulary*, developed by Subcommittee 1, Joint Technical Committee 1, of the International Organization for Standardization and the International Electrotechnical Commission (ISO/IEC JTC1/SC1). Definitions of published parts of this vocabulary are identified by the symbol (I) after the definition; definitions taken from draft international standards, committee drafts, and working papers being developed by ISO/IEC JTC1/SC1 are identified by the symbol (T) after the definition, indicating that final agreement has not yet been reached among the participating National Bodies of SC1.
- The Network Working Group Request for Comments: 1208.

The following cross-references are used in this glossary:

**Contrast with:** This refers to a term that has an opposed or substantively different meaning.

**Synonym for:** This indicates that the term has the same meaning as a preferred term, which is defined in its proper place in the glossary.

**Synonymous with:** This is a backward reference from a defined term to all other terms that have the same meaning.

**See:** This refers the reader to multiple-word terms that have the same last word.

**See also:** This refers the reader to terms that have a related, but not synonymous, meaning.

## A

**ACF/TAP.** Advanced Communications Function/Trace Analysis Program. Synonymous with *TAP*.

**ACF/TCAM.** Advanced Communications Function for the Telecommunications Access Method. Synonym for *TCAM*.

**ACF/VTAM.** Advanced Communications Function for the Virtual Telecommunications Access Method. Synonym for *VTAM*.

**acknowledgment.** (1) The transmission, by a receiver, of acknowledge characters as an affirmative response to a sender. (T) (2) An indication that an item sent was received.

**ACTPU.** Activate physical unit. In SNA, a command used to start a session on a physical unit.

**adapter.** A part that electrically or physically connects a device to a computer or to another device.

**adapter control block (ACB).** In NCP, a control block that contains line control information and the states of I/O operations for BSC lines, SS lines, or SDLC links.

**adaptive pacing.** Synonym for *adaptive session-level pacing* and *virtual route pacing*.

**adaptive session-level pacing.** A form of session-level pacing in which session components exchange pacing windows that may vary in size during the course of a session. This allows transmission within a network to adapt dynamically to variations in availability and demand of buffers on a session-by-session basis. Session-level pacing occurs within independent stages along the session path according to local congestion at the intermediate and endpoint nodes. Synonymous with *adaptive pacing* and *adaptive session pacing*. See *pacing*, *session-level pacing*, and *virtual route pacing*.

**adaptive session pacing.** Synonym for *adaptive session-level pacing*.

**address class.** In Internet communications, the categorization by the part of an IP address that distinguishes the network address from the host address. Class A addresses allocate 7 bits to the network ID and 24 bits to the host ID. Class B addresses allocate 14 bits to the network ID and 16 bits to the host ID. Class C addresses allocate 21 bits to the network ID and 8 bits to the host ID. Class D addresses contain 1110 in the first 4 bits and identify the address as a multicast.

## Glossary

The remaining 28 bits in the class D address specify a particular multicast group.

**address mask.** For internet subnetting, a 32-bit mask used to identify the subnetwork address bits in the host portion of an internet address. Synonymous with *subnet mask* and *subnetwork mask*.

**address resolution.** A method for mapping network-layer addresses to media-specific addresses. See also *Address Resolution Protocol (ARP)*.

**Address Resolution Protocol (ARP).** A protocol that dynamically maps between Internet addresses, baseband adapter addresses, X.25 addresses, and Token-Ring adapter addresses on a local area network.

**adjacent link station (ALS).** (1) In SNA, a link station directly connected to a given node by a link connection over which network traffic can be carried.

**Note:** Several secondary link stations that share a link connection do not exchange data with each other and therefore are not adjacent to each other. (2) With respect to a specific node, a link station partner in an adjacent node.

**adjacent NCPs.** Network control programs (NCPs) that are connected by subarea links with no intervening NCPs.

**adjacent networks.** Two SNA networks joined by a common gateway NCP.

**adjacent nodes.** Two nodes connected together by at least one path that connects no other node. (T)

**adjacent subareas.** Two subareas connected by one or more links with no intervening subareas. See also *subarea*.

**Advanced Communications Function (ACF).** A group of IBM licensed programs, principally VTAM, TCAM, NCP, and SSP, that use the concepts of Systems Network Architecture (SNA), including distribution of function and resource sharing.

**Advanced Communications Function/Trace Analysis Program (ACF/TAP).** An SSP program service aid that assists in analyzing trace data produced by VTAM, TCAM, and NCP and provides network data traffic and network error reports. Synonymous with *Trace Analysis Program (TAP)*.

**Advanced Peer-to-Peer Networking (APPN).** An extension to SNA featuring (a) greater distributed network control that avoids critical hierarchical dependencies, thereby isolating the effects of single points of failure; (b) dynamic exchange of network topology information to foster ease of connection, reconfiguration, and adaptive route selection; (c) dynamic definition of

network resources; and (d) automated resource registration and directory lookup. APPN extends the LU 6.2 peer orientation for end-user services to network control and supports multiple LU types, including LU 2, LU 3, and LU 6.2.

**Advanced Peer-to-Peer Networking (APPN) end node.** A node that provides a broad range of end-user services and supports sessions between its local control point (CP) and the CP in an adjacent network node. It uses these sessions to dynamically register its resources with the adjacent CP (its network node server), to send and receive directory search requests, and to obtain management services. An APPN end node can also attach to a subarea network as a peripheral node or to other end nodes.

**Advanced Peer-to-Peer Networking (APPN) network.** A collection of interconnected network nodes and their client end nodes.

**Advanced Peer-to-Peer Networking (APPN) network node.** A node that offers a broad range of end-user services and that can provide the following:

- Distributed directory services, including registration of its domain resources to a central directory server
- Topology database exchanges with other APPN network nodes, enabling network nodes throughout the network to select optimal routes for LU-LU sessions based on requested classes of service
- Session services for its local LUs and client end nodes
- Intermediate routing services within an APPN network

**Advanced Peer-to-Peer Networking (APPN) node.** An APPN network node or an APPN end node.

**alert.** (1) A message sent to a management services focal point in a network to identify a problem or an impending problem. (2) In the NetView and NETCENTER programs, a high priority event that warrants immediate attention.

**alias address.** An address used by a gateway NCP and a gateway system services control point (SSCP) in one network to represent a logical unit (LU) or SSCP in another network.

**American National Standards Institute (ANSI).** An organization consisting of producers, consumers, and general interest groups, that establishes the procedures by which accredited organizations create and maintain voluntary industry standards in the United States. (A)

**analog.** (1) Pertaining to data consisting of continuously variable physical quantities. (A) (2) Contrast with *digital*.

**application.** A collection of software components used to perform specific types of user-oriented work on a computer.

**application program.** (1) A program written for or by a user that applies to the user's work, such as a program that does inventory control or payroll. (2) A program used to connect and communicate with stations in a network, enabling users to perform application-oriented activities.

**APPN end node.** See *Advanced Peer-to-Peer Networking (APPN) end node*.

**APPN network.** See *Advanced Peer-to-Peer Networking (APPN) network*.

**APPN network node.** See *Advanced Peer-to-Peer Networking (APPN) network node*.

**APPN node.** See *Advanced Peer-to-Peer Networking (APPN) node*.

**ASCII (American Standard Code for Information Interchange).** The standard code, using a coded character set consisting of 7-bit coded characters (8-bit including parity check), that is used for information interchange among data processing systems, data communication systems, and associated equipment. The ASCII set consists of control characters and graphic characters. (A)

**Note:** IBM has defined an extension to ASCII code (characters 128–255).

**auto-call.** Synonym for *automatic calling*.

**automatic calling.** A feature that permits a station to initiate a connection with another station over a switched line without operator action. Synonymous with *auto-call*.

**automatic calling unit (ACU).** A dialing device that permits a computer to automatically dial calls over a network.

## B

**B-channel.** In the integrated services digital network (ISDN), a 64 kilobits-per-second channel for the transport of speech or data between the ISDN service provider and user.

**backbone.** (1) A set of nodes and their interconnecting links providing the primary data path across a network. (2) In a local area network multiple-bridge ring configuration, a high-speed link to which the rings are connected by means of bridges or routers. A backbone may be configured as a bus or as a ring. (3) In a wide area network, a high-speed link to which nodes or data switching exchanges (DSEs) are connected.

**backup session.** The session that replaces the failing primary extended recovery facility (XRF) session between a terminal user and the active subsystem.

**BHSET.** Block handler routines.

**binary synchronous communication (BSC).** A form of telecommunication line control that uses a standard set of transmission control characters and control character sequences, for binary synchronous transmission of binary-coded data between stations. Contrast with *Synchronous Data Link Control (SDLC)*.

**binary synchronous transmission.** Data transmission in which synchronization of characters is controlled by timing signals generated at the sending and receiving stations. See also *start-stop transmission* and *Synchronous Data Link Control (SDLC)*.

**BIND.** In SNA, a request to activate a session between two logical units (LUs). See also *session activation request*. Contrast with *UNBIND*.

**block.** A string of data elements recorded or transmitted as a unit. The elements may be characters, words, or physical records. (T)

**blocking of PIUs.** In SNA, an optional function of path control that combines multiple path information units (PIUs) in a single basic transmission unit (BTU).

**Note:** When blocking is not done, a BTU consists of one PIU.

**border node.** An APPN network node that interconnects APPN networks having independent topology databases in order to support LU-LU sessions between these networks. See *extended border node* and *peripheral border node*.

**boundary access node (BAN).** A router (such as the IBM 6611) that provides its attached LAN-based SNA peripheral nodes direct frame-relay access to a subarea boundary node (such as an IBM 3745 or 3746 Model 900).

**boundary function.** (1) In SNA, a capability of a subarea node to provide protocol support for attached peripheral nodes, such as: (a) interconnecting subarea path control and peripheral path control elements, (b) performing session sequence numbering for low-function peripheral nodes, and (c) providing session-level pacing support. (2) In SNA, the component that provides these capabilities.

**boundary node (BN).** In SNA, a subarea node with boundary function.

**Note:** A subarea node may be a boundary node, an intermediate routing node, both, or neither, depending on how it is used in the network.

## Glossary

**bridge.** (1) A functional unit that interconnects two local area networks that use the same logical link control protocol but may use different medium access control protocols. (T) (2) A functional unit that interconnects multiple LANs (locally or remotely) that use the same logical link control protocol but that can use different medium access control protocols. A bridge forwards a frame to another bridge based on the medium access control (MAC) address. (3) In the connection of local loops, channels, or rings, the equipment and techniques used to match circuits and to facilitate accurate data transmission. (4) See also *gateway*.

**broadcast.** Transmission of the same data to all destinations. (T)

**buffer.** A portion of storage used to hold input or output data temporarily.

**bus.** (1) A facility for transferring data between several devices located between two end points, only one device being able to transmit at a given moment. (T) (2) A computer configuration in which processors are interconnected in series.

## C

**call.** In data communication, the actions necessary to make a connection between two stations on a switched line.

**call establishment.** The complete sequence of events necessary to establish a data connection.

**call progress signal.** A call control signal transmitted from the data circuit-terminating equipment (DCE) to the calling data terminal equipment (DTE) to indicate the progress of the establishment of a call, the reason why the connection could not be established, or any other network condition. (T)

**CALLIN.** The logical channel type on which the data terminal equipment (DTE) can receive a call but cannot send one.

**calling.** (1) The process of transmitting selection signals in order to establish a connection between data stations. (I) (A) (2) In X.25 communications, pertaining to the location or user that makes a call.

**CALLOUT.** The logical channel type on which the data terminal equipment (DTE) can send a call, but cannot receive one.

**carrier sense.** In a local area network, an ongoing activity of a data station to detect whether another station is transmitting. (T)

**carrier sense multiple access with collision detection (CSMA/CD).** A protocol that requires carrier

sense and in which a transmitting data station that detects another signal while transmitting, stops sending, sends a jam signal, and then waits for a variable time before trying again. (T) (A)

**casual connection.** (1) In a subarea network, a connection in which type 5 nodes are attached through the boundary function using low-entry networking (LEN). Therefore, the nodes appear as LEN nodes rather than subarea nodes. (2) In an APPN network, a connection between an end node and a network node with different network identifiers.

**chain.** (1) A group of logically linked user data records processed by LU 6.2. (2) A group of request units delimited by begin-chain and end-chain. Responses are always single-unit chains. See *RU chain*.

**channel.** A path along which signals can be sent, for example, data channel, output channel. (A)

**channel adapter.** A communication controller hardware unit that is used to attach the communication controller to a host channel.

**channel-attached.** (1) Pertaining to the attachment of devices directly by input/output channels to a host processor. (2) Pertaining to devices attached to a controlling unit by cables, rather than by telecommunication lines. Contrast with *link-attached*. Synonymous with *local*.

**channel link.** A System/370 I/O channel to control unit interface that has an SNA network address. A channel link can be either a subarea link or a peripheral link and is defined in an NCP generation definition using the GROUP, LINE, and PU definition statements. See also *link* and *subarea link*.

**character times.** The maximum number of times the temporary text delay character can be sent to a terminal before the operation stops or that can be sent between the end of a receive and the beginning of a transmit operation.

**circuit switching.** (1) A process that, on demand, connects two or more data terminal equipment (DTEs) and permits the exclusive use of a data circuit between them until the connection is released. (I) (A) (2) Synonymous with *line switching*. (3) See also *message switching* and *packet switching*.

**clocking.** (1) In binary synchronous communication, the use of clock pulses to control synchronization of data and control characters. (2) A method of controlling the number of data bits sent on a telecommunication line in a given time.

**cluster.** A station that consists of a control unit (a cluster controller) and the terminals attached to it.

**cluster controller.** A device that can control the input/output operations of more than one device connected to it. A cluster controller may be controlled by a program stored and executed in the unit; for example, the IBM 3601 Finance Communication Controller. Or, it may be entirely controlled by hardware; for example, the IBM 3272 Control Unit. See also *cluster*.

**collision.** An unwanted condition that results from concurrent transmissions on a channel. (T)

**collision detection.** In carrier sense multiple access with collision detection (CSMA/CD), a signal indicating that two or more stations are transmitting simultaneously.

**communication controller.** A type of communication control unit whose operations are controlled by one or more programs stored and executed in the unit. It manages the details of line control and the routing of data through a network.

**communication line processor (CLP).** In a communications controller, the processor that manages telecommunications lines.

**communication management configuration host node.** The type 5 host processor in a communication management configuration that does all network-control functions in the network except for the control of devices channel-attached to data hosts. Synonymous with *communication management host*. Contrast with *data host node*.

**communication management host.** Synonym for *communication management configuration host node*. Contrast with *data host*.

**communication network management (CNM).** The process of designing, installing, operating, and managing distribution of information and control among users of communication systems.

**computer word.** A word suitable for processing by a given computer, usually treated as a unit. (T) Synonymous with *fullword*.

**configuration.** (1) The manner in which the hardware and software of an information processing system are organized and interconnected. (T) (2) The devices and programs that make up a system, subsystem, or network.

**congestion.** See *network congestion*.

**connection.** (1) In data communication, an association established between functional units for conveying information. (I) (A) (2) In Open Systems Interconnection architecture, an association established by a given layer between two or more entities of the next

higher layer for the purpose of data transfer. (T) (3) In SNA, the network path that links together two logical units (LUs) in different nodes to enable them to establish communications. (4) In X.25 communication, a virtual circuit between two data terminal equipments (DTEs). A switched virtual circuit (SVC) connection lasts for the duration of a call; a permanent virtual circuit (PVC) is a permanent connection between the DTEs. (5) In TCP/IP, the path between two protocol applications that provides reliable data stream delivery service. In Internet, a connection extends from a TCP application on one system to a TCP application on another system.

**connection balancing.** A method of distributing, across all duplicate TICs, incoming call requests that are initiated by downstream peripheral devices.

**connectivity.** (1) The capability of a system or device to be attached to other systems or devices without modification. (T) (2) The capability to attach a variety of functional units without modifying them.

**connectivity subsystem (CSS).** An expansion frame, such as the 3746 Model 900, that extends connectivity and enhances the performance of the IBM 3745 Communication Controller.

**control block.** (1) A storage area used by a computer program to hold control information. (I) (2) In the IBM Token-Ring Network, a specifically formatted block of information provided from the application program to the Adapter Support Interface to request an operation.

**control point (CP).** (1) A component of an APPN or LEN node that manages the resources of that node. In an APPN node, the CP is capable of engaging in CP-CP sessions with other APPN nodes. In an APPN network node, the CP also provides services to adjacent end nodes in the APPN network. (2) A component of a node that manages resources of that node and optionally provides services to other nodes in the network. Examples are a system services control point (SSCP) in a type 5 subarea node, a network node control point (NNCP) in an APPN network node, and an end node control point (ENCP) in an APPN or LEN end node. An SSCP and an NNCP can provide services to other nodes.

**controller.** A device that coordinates and controls the operation of one or more input/output devices, such as workstations, and synchronizes the operation of such devices with the operation of the system as a whole.

**conversational monitor system (CMS).** A virtual machine operating system that provides general interactive time sharing, problem solving, and program development capabilities, and operates only under control of the VM/370 control program.

## Glossary

**coupler.** A device that connects a modem to a telephone network.

**cross-domain.** In SNA, pertaining to control or resources involving more than one domain.

**cross-network.** In SNA, pertaining to control or resources involving more than one network.

**cross-network session.** An LU-LU or SSCP-SSCP session whose path traverses more than one SNA network.

**Customer Information Control System (CICS).** An IBM licensed program that enables transactions entered at remote terminals to be processed concurrently by user-written application programs. It includes facilities for building, using, and maintaining databases.

**CWALL.** An NCP threshold of buffer availability, below which the NCP will accept only high-priority path information units (PIUs).

## D

**D-channel.** In the integrated services digital network (ISDN), a 16 kilobits-per-second channel for the transport of packet data or call establishment information between the ISDN service provider and user.

**data.** (1) A re-interpretable representation of information in a formalized manner suitable for communication, interpretation, or processing. Operations can be performed upon data by humans or by automatic means. (T) (2) Any representations such as characters or analog quantities to which meaning is or might be assigned. (A) (3) A representation of facts or instructions in a form suitable for communication, interpretation, or processing by human or automatic means. Data include constants, variables, arrays, and character strings.

**Note:** Programmers make a distinction between instructions and the data they operate on; however, in the usual sense of the word, data includes programs and program instructions.

**data check.** (1) An operation used to verify data quality or data integrity. (T) (2) A synchronous or asynchronous indication of a condition caused by invalid data or incorrect positioning of data. Some data checks can be suppressed.

**data host.** Synonym for *data host node*. Contrast with *communication management configuration host*.

**data host node.** In a communication management configuration, a type 5 host node that is dedicated to processing applications and does not control network resources, except for its channel-attached or communi-

cation adapter-attached devices. Synonymous with *data host*. Contrast with *communication management configuration host node*.

**data link connection identifier (DLCI).** The numeric identifier of a frame-relay subport or PVC segment in a frame-relay network. Each subport in a single frame-relay port has a unique DLCI. The following table, excerpted from the American National Standards Institute (ANSI) Standard T1.618 and the International Telegraph and Telephone Consultative Committee (CCITT) Standard Q.922, indicates the functions associated with certain DLCI values:

DLCI Values	Function
0	in-channel signaling
1–15	reserved
16–991	assigned using frame-relay connection procedures
992–1007	layer 2 management of frame-relay bearer service
1008–1022	reserved
1023	in-channel layer management

**data link control (DLC).** A set of rules used by nodes on a data link (such as an SDLC link or a Token Ring) to accomplish an orderly exchange of information.

**data link control (DLC) layer.** In SNA, the layer that consists of the link stations that schedule data transfer over a link between two nodes and perform error control for the link. Examples of data link control are SDLC for serial-by-bit link connection and data link control for the System/370 channel.

**Note:** The DLC layer is usually independent of the physical transport mechanism and ensures the integrity of data that reaches the higher layers.

**data link level.** (1) In the hierarchical structure of a data station, the conceptual level of control or processing logic between high level logic and the data link that maintains control of the data link. The data link level performs such functions as inserting transmit bits and deleting receive bits; interpreting address and control fields; generating, transmitting, and interpreting commands and responses; and computing and interpreting frame check sequences.

**data stream.** (1) All information (data and control commands) sent over a data link usually in a single read or write operation. (2) A continuous stream of data elements being transmitted, or intended for transmission, in character or binary-digit form, using a defined format.

**data terminal equipment (DTE).** That part of a data station that serves as a data source, data sink, or both. (I) (A)



**data transfer rate.** The average number of bits, characters, or blocks per unit time passing between corresponding equipment in a data transmission system. (I)

**Notes:**

1. The rate is expressed in bits, characters, or blocks per second, minute, or hour.
2. Corresponding equipment should be indicated; for example, modems, intermediate equipment, or source and sink.

**database.** (1) A collection of data with a given structure for accepting, storing, and providing, on demand, data for multiple users. (T) (2) A collection of interrelated data organized according to a database schema to serve one or more applications. (T) (3) A collection of data fundamental to a system. (A) (4) A collection of data fundamental to an enterprise. (A)

**datagram.** (1) In packet switching, a self-contained packet, independent of other packets, that carries information sufficient for routing from the originating data terminal equipment (DTE) to the destination DTE without relying on earlier exchanges between the DTEs and the network. (I) (2) In TCP/IP, the basic unit of information passed across the Internet environment. A datagram contains a source and destination address along with the data. An Internet Protocol (IP) datagram consists of an IP header followed by the transport layer data. See also *packet* and *segment*.

**ddname.** Data definition name.

**default.** Pertaining to an attribute, condition, value, or option that is assumed when none is explicitly specified. (I)

**definite response (DR).** In SNA, a protocol requested in the form-of-response-requested field of the request header that directs the receiver of the request to return a response unconditionally, whether positive or negative, to that request chain. Contrast with *exception response* and *no response*.

**definition statement.** (1) An instruction that defines an NCP or VTAM resource.

**destination.** Any point or location, such as a node, station, or a particular terminal, to which information is to be sent.

**destination address.** A code that identifies the location to which information is to be sent.

**destination service access point (DSAP).** In SNA and TCP/IP, a logical address that allows a system to route data from a remote device to the appropriate communications support. Contrast with *source service access point (SSAP)*.

**dial-in.** Pertaining to the direction in which a switched connection is requested by any node or terminal other than the receiving host or an NCP.

**dial-out.** Pertaining to the direction in which a switched connection is requested by a host or an NCP.

**dialog.** (1) The interaction between a user and a computer. (2) In an interactive system, a series of related inquiries and responses similar to a conversation between two people.

**digital.** (1) Pertaining to data that consist of digits. (T) (2) Pertaining to data in the form of digits. (A) (3) Contrast with *analog*.

**distributed processing.** Processing that takes place across two or more linked systems.

**domain.** That part of a computer network in which the data processing resources are under common control. (T)

**dotted decimal notation.** The syntactical representation for a 32-bit integer that consists of four 8-bit numbers written in base 10 with periods (dots) separating them. It is used to represent IP addresses.

**dump.** (1) To record, at a particular instant, the contents of all or part of one storage device in another storage device. Dumping is usually for the purpose of debugging. (T) (2) Data that has been dumped. (T) (3) To copy data in a readable format from main or auxiliary storage onto an external medium such as tape, diskette, or printer. (4) To copy the contents of all or part of virtual storage for the purpose of collecting error information.

**duplex.** Pertaining to communication in which data can be sent and received at the same time. Synonymous with *full duplex*. Contrast with *half duplex*.

**dynamic.** Pertaining to an operation that occurs at the time it is needed rather than at a predetermined or fixed time.

**dynamic path update.** The process of changing the network path for sending information without regenerating complete configuration tables.

**dynamic reconfiguration (DR).** The process of changing the network configuration (peripheral PUs and LUs) without regenerating complete configuration tables or deactivating the affected major node.

**dynamic reconfiguration data set (DRDS).** In VTAM, a data set used for storing definition data that can be applied to a generated communication controller configuration at the operator's request, or can be used to accomplish dynamic reconfiguration of NCP, local SNA, and packet major nodes. A dynamic reconfiguration

## Glossary

data set can be used to dynamically add PUs and LUs, delete PUs and LUs, and move PUs. It is activated with the VARY DRDS operator command. See also *dynamic reconfiguration*.

## E

**early token release.** A function, supported by Token-Ring adapter types 2 and 3, that allows a transmitting station to release the token after transmitting the ending delimiter.

**EBCDIC.** Extended binary-coded decimal interchange code. A coded character set consisting of 8-bit coded characters. (A)

**echo.** In data communication, a reflected signal on a communications channel. On a communications terminal, each signal is displayed twice, once when entered at the local terminal and again when returned over the communications link. This allows the signals to be checked for accuracy.

**element.** (1) A field in the network address. (2) In SNA, the particular resource within a subarea that is identified by an element address. See also *subarea*.

**element address.** In SNA, a value in the element address field of the network address identifying a specific resource within a subarea. See *subarea address*.

**emulation mode.** The function of a network control program that enables it to perform activities equivalent to those performed by a transmission control unit. Contrast with *network control mode*.

**Emulation Program (EP).** An IBM control program that allows a channel-attached 3705 or 3725 communication controller to emulate the functions of an IBM 2701 Data Adapter Unit, an IBM 2702 Transmission Control, or an IBM 2703 Transmission Control. See also *network control program*.

**end node (EN).** (1) See *Advanced Peer-to-Peer Networking (APPN) end node* and *low-entry networking (LEN) end node*. (2) In communications, a node that is frequently attached to a single data link and cannot perform intermediate routing functions.

**end-of-transmission (EOT) character.** (1) A transmission control character used to indicate conclusion of a transmission that may have included one or more texts and associated message headings. (I) (A) (2) In binary synchronous communication, the transmission control character usually used to end communication.

**Enterprise Systems Connection (ESCON).** A set of IBM products and services that provide a dynamically connected environment within an enterprise.

**ESCON Director (ESCD).** A switch for ESCON optical channels that provides connectivity capability and control for attaching any two links to each other.

**ESCON processor (ESCP).** A processor within the 3746 Model 900 connectivity subsystem (CSS) that performs ESCON function.

**Ethernet.** A 10-Mbps baseband local area network that allows multiple stations to access the transmission medium at will without prior coordination, avoids contention by using carrier sense and deference, and resolves contention by using collision detection and transmission. Ethernet uses carrier sense multiple access with collision detection (CSMA/CD).

**Ethernet-type LAN.** A local area network that uses either the Ethernet Version 2 or IEEE 802.3 protocol.

**event.** (1) An occurrence of significance to a task; for example, the completion of an asynchronous operation, such as an input/output operation. (2) In the NetView program, a record indicating irregularities of operation in physical elements of a network.

**exception.** An abnormal condition such as an I/O error encountered in processing a data set or a file.

**exchange identification (XID).** A specific type of basic link unit that is used to convey node and link characteristics between adjacent nodes. XIDs are exchanged between link stations before and during link activation to establish and negotiate link and node characteristics, and after link activation to communicate changes in these characteristics.

**EXEC.** In a VM operating system, a user-written command file that contains CMS commands, other user-written commands, and execution control statements, such as branches.

**explicit route (ER).** In SNA, a series of one or more transmission groups that connect two subarea nodes. An explicit route is identified by an origin subarea address, a destination subarea address, an explicit route number, and a reverse explicit route number. Contrast with *virtual route (VR)*.

**extended architecture (XA).** An extension to System/370 architecture that takes advantage of continuing high performance enhancements to computer system hardware.

**extended binary-coded decimal interchange code (EBCDIC).** A coded character set of 256 8-bit characters.

**extended border node.** A border node that interconnects (a) APPN networks having different network identifiers or (b) separate partitions of the same APPN network, where the partitioning is to allow isolated

topology subnetworks (or clusters). An extended border node supports intermediate network routing, allowing it to support LU-LU sessions that do not terminate in its native network. Contrast with *peripheral border node*.

**extended network addressing.** The network addressing system that splits the address into an 8-bit subarea and a 15-bit element portion. The subarea portion of the address is used to address host processors or communication controllers. The element portion is used to permit processors or controllers to address resources.

**extended recovery facility (XRF).** A facility that minimizes the effect of failures in MVS, VTAM, the host processor, or high availability applications during sessions between high availability applications and designated terminals. This facility provides an alternate subsystem to take over sessions from the failing subsystem.

**extended subarea addressing.** A network addressing system that is used in a network with more than 255 subareas.

**external PVC segment.** In NCP, a permanent virtual circuit (PVC) segment between two frame-relay subports in adjacent NCPs. When the two NCPs are directly attached, the two subports have the same data link connection identifier (DLCI). A permanent virtual circuit (PVC) segment between two frame-relay subports that have the same data link connection identifier.

## F

**fallback.** In an IBM 3745 Communication Controller with twin central control units (CCUs) in standby or backup mode, the process by which buses are switched from the failing CCU to the active CCU (backup mode) or the idle CCU (standby mode) to recover the path of communication flow in the failed CCU. See also *switchback*.

**fanout.** A feature that allows several data terminal equipment (DTEs) to share the same modem. Only one DTE can transmit at a time.

**FASTRUN.** One of several options available with the NCP/EP definition facility (NDF) that indicates that only the syntax is to be checked in generation definition statements.

**flow control.** In SNA, the process of managing the rate at which data traffic passes between components of the network. The purpose of flow control is to optimize the rate of flow of message units with minimum congestion in the network; that is, to neither overflow the buffers at the receiver or at intermediate routing nodes, nor leave the receiver waiting for more message

units. See also *adaptive session-level pacing*, *pacing*, and *session-level pacing*.

**frame.** (1) The unit of transmission in some local area networks, including the IBM Token-Ring Network. It includes delimiters, control characters, information, and checking characters. (2) In SDLC, the vehicle for every command, every response, and all information that is transmitted using SDLC procedures.

**frame handler (FH).** Synonym for *frame-relay frame handler (FRFH)*.

**frame handler subport (FHSP).** The access point of a frame-relay frame handler to a PVC segment. Frame handler subports function in pairs; frames enter the frame handler through one frame handler subport and exit through the other. Contrast with *terminating equipment subport*. See also *subport set*.

**frame level.** See *link level*.

**frame relay.** (1) An interface standard describing the boundary between a user's equipment and a fast-packet network. In frame-relay systems, flawed frames are discarded; recovery comes end-to-end rather than hop-by-hop. (2) A technique derived from the integrated services digital network (ISDN) D-channel standard. It assumes that connections are reliable and dispenses with the overhead of error detection and control within the network.

**frame-relay connection.** See *frame-relay physical line* and *permanent virtual circuit (PVC)*.

**frame-relay frame.** The frame-relay frame structure defined by American National Standards Institute (ANSI) Standard T1.618.

**frame-relay frame handler (FRFH).** (1) The function in a frame-relay node that routes (or switches) frames along a permanent virtual circuit (PVC). A frame handler receives frames from an adjacent frame-relay node and uses the DLCI to forward them to the next node on the PVC. Synonymous with *frame handler*. See also *frame-relay switching equipment support* and *frame-relay terminating equipment*. (2) In NCP, the function that switches frames between frame handler subports on an internal PVC segment. The NCP frame handler function can also switch frames to the frame-relay terminating equipment function.

**frame-relay network.** A network that consists of frame-relay frame handlers (FRFH) and in which frames are passed from one frame-relay terminal equipment (FRTE) station to another through a series of one or more FRFHs.

**frame-relay physical line.** The physical connection between two frame-relay nodes. A frame-relay physical line can simultaneously support PVC segments for both

## Glossary

the frame-handler and terminating-equipment functions. In NCP, a frame-relay physical line is defined as a non-switched duplex line.

**frame-relay switching equipment (FRSE).** See *frame-relay switching equipment (FRSE) support*.

**frame-relay switching equipment (FRSE) support set.** The set of primary and, optionally, substitute frame handler supports (FHSP) that comprise those used for a given frame-relay segment set.

**frame-relay switching equipment (FRSE) support.** In NCP, a set of frame-relay functions that include the frame-relay frame handler function and the local management interface (LMI) function. These functions are defined by American National Standards Institute (ANSI) Standards T1.617 and T1.618 and International Telegraph and Telephone Consultative Committee (CCITT) Standards Q.922 and Q.933. NCP provides additional functions, including performance measurement and enhanced reliability, that are not defined by ANSI or CCITT standards.

**frame-relay terminal equipment.** A device that can connect to a frame-relay network and provide the frame-relay terminating equipment function. See also *frame-relay frame handler* and *frame-relay terminating equipment*.

**frame-relay terminating equipment (FRTE).** The function at the end of a frame-relay permanent virtual circuit (PVC). Frame-relay terminating equipment provides higher-layer protocols with access to a frame-relay network through terminating equipment supports (TESPs). It does this by (a) adding frame-relay frame headers to data for another protocol and sending the frames to adjacent frame-relay nodes, and (b) receiving frames from adjacent frame-relay nodes and removing the frame headers. See also *frame-relay frame handler*, *frame-relay switching equipment support*, and *frame-relay terminal equipment*.

**frame switching.** The function performed by frame-relay nodes to route frames through a network. See also *frame-relay frame handler*.

**frequency.** The rate of signal oscillation, expressed in hertz.

**full duplex (FDX).** Synonym for *duplex*.

**fullword.** Synonym for *computer word*.

## G

**gateway.** (1) A functional unit that interconnects two computer networks with different network architectures. A gateway connects networks or systems of different architectures. A bridge interconnects networks or systems with the same or similar architectures. (T) (2) In TCP/IP, a device used to connect two systems that use either the same or different communications protocols. (3) The combination of machines and programs that provide address translation, name translation, and system services control point (SSCP) rerouting between independent SNA networks to allow those networks to communicate. A gateway consists of one gateway NCP and at least one gateway VTAM. (4) In the IBM Token-Ring Network, a device and its associated software that connect a local area network to another local area network or a host that uses different logical link protocols.

**gateway NCP.** An NCP that performs address translation to allow cross-network session traffic. The gateway NCP connects two or more independent SNA networks. Synonymous with *gateway node*.

**gateway node.** Synonym for *gateway NCP*.

**gateway SSCP.** Synonym for *gateway VTAM*.

**gateway VTAM.** An SSCP that is capable of cross-network session initiation, termination, takedown, and session outage notification. A gateway VTAM is in session with the gateway NCP; it provides network name translation and assists the gateway NCP in setting up alias network addresses for cross-network sessions. Synonymous with *gateway SSCP*.

**generation.** The process of assembling and link editing definition statements so that resources can be identified to all the necessary programs in a network.

**generation definition.** In NCP, a set of definition statements and associated keywords that define the resources for an NCP.

**generic alert.** A product-independent method of encoding alert data by means of both (a) code points indexing short units of stored text and (b) textual data.

**generic unbind.** Synonym for *session deactivation request*.

**group polling.** A process whereby a single poll is sent to a collection point for a group of stations, inviting a response from any station in the group that has data to send.

## H

**half-duplex (HD, HDX).** In data communication, pertaining to transmission in only one direction at a time. Contrast with *duplex*. See also *half-duplex operation* and *half-duplex transmission*.

**half-duplex operation.** A mode of operation of a data link in which data can be transmitted in both directions, one way at a time. (T)

**half-duplex transmission.** Data transmission in either direction, one direction at a time. (I) (A)

**half-session.** A session-layer component consisting of the combination of data flow control and transmission control components comprising one end of a session.

**halfword.** A contiguous sequence of bits or characters that constitutes half a computer word and can be addressed as a unit. (A)

**hardcopy.** A printed copy of machine output in a visually readable form; for example, printed reports, listings, documents, and summaries. Contrast with *softcopy*.

**hardware configuration definition.** An interactive tool that can be used to define hardware configurations to the operating system and the channel subsystem.

**header.** (1) System-defined control information that precedes user data. (2) The portion of a message that contains control information for the message such as one or more destination fields, name of the originating station, input sequence number, character string indicating the type of message, and priority level for the message.

**hello datagram.** (1) In the Internet suite of protocols, a hello message sent periodically to establish and test reachability between routers or between routers and hosts. The message is defined by the Hello protocol as an Interior Gateway Protocol (IGP). (2) In NCP IP support, an Internet Protocol (IP) datagram that establishes and verifies communication between an NCP IP router and its IP owner.

**high-performance transmission subsystem (HPTSS).** A high-speed line adapter that attaches to the IBM 3745 Communication Controller.

**hop count.** (1) A metric or measure of distance between two points. (2) In Internet communications, the number of routers that a datagram passes through on its way to its destination.

**host.** In the Internet suite of protocols, an end system. The end system can be any workstation; it does not have to be a mainframe.

**host node.** (1) A node at which a host computer is located. (T) (2) A node that provides an application program interface (API) and a common application interface. See *boundary node*, *node*, *peripheral node*, *subarea host node*, and *subarea node*. See also *boundary function* and *node type*.

**host processor.** (1) A processor that controls all or part of a user application network. (T) (2) In a network, the processing unit in which the data communication access method resides.

**hypertext link.** A pointer from a location in an online book to another location in the same book or another book. When selected, a hypertext link enables you to move quickly to the new location containing related information. BookManager associates terms with related information such as the glossary, a message or code, an index entry, or a language element reference. Cross-references indicated by markup are automatically linked to the referenced location.

## I

**I-frame.** Information frame.

**idle character.** A character transmitted on a telecommunication line that is not intended to represent data and does not result in an output operation at the accepting terminal.

**inbound.** In communications, data that is received from the network.

**independent LU.** See *SSCP-independent LU*.

**indirect routing.** In Internet communications, the transmission of a datagram to a router for forwarding to a destination that resides on a different network from the source.

**information (I) format.** A format used for information transfer.

**information (I) frame.** A frame in I format used for numbered information transfer.

**initial program load (IPL).** (1) The initialization procedure that causes an operating system to commence operation. (2) The process by which a configuration image is loaded into storage at the beginning of a work day or after a system malfunction. (3) The process of loading system programs and preparing a system to run jobs.

**input/output channel.** (1) In a data processing system, a functional unit that handles transfer of data between internal and peripheral equipment. (I) (A) (2) In a computing system, a functional unit, controlled by a processor, that handles transfer of data between

## Glossary

processor storage and local peripheral devices. Synonymous with *data channel*. See *channel*. See also *link*.

**insert.** In LANs, to make an attaching device an active part of the LAN.

**integrated services digital network (ISDN).** A digital end-to-end telecommunication network that supports multiple services including, but not limited to, voice and data.

**Note:** ISDNs are used in public and private network architectures.

**interconnected networks.** SNA networks connected by gateways.

**interconnection.** See *SNA network interconnection (SNI)*.

**interface.** (1) A shared boundary between two functional units, defined by functional characteristics, signal characteristics, or other characteristics, as appropriate. The concept includes the specification of the connection of two devices having different functions. (T) (2) Hardware, software, or both, that links systems, programs, or devices.

**internal PVC segment.** A permanent virtual circuit (PVC) segment between two frame handler subports in the same frame-relay node.

**International Telecommunication Union - Telecommunication Standardization Sector.** The part of the International Telecommunication Union (ITU) that is responsible for developing recommendations for telecommunications.

**internet.** A collection of networks interconnected by a set of routers that allow them to function as a single, large network. See also *Internet*.

**Internet.** The internet administered by the Internet Architecture Board (IAB), consisting of large national backbone networks and many regional and campus networks all over the world. The Internet uses the Internet suite of protocols.

**Internet address.** See *IP address*.

**Internet Control Message Protocol (ICMP).** The protocol used to handle errors and control messages in the Internet Protocol (IP) layer. Reports of problems and incorrect datagram destinations are returned to the original datagram source. ICMP is part of the Internet Protocol.

**Internet Protocol (IP).** A connectionless protocol that routes data through a network or interconnected networks. IP acts as an intermediary between the higher protocol layers and the physical network. However, this

protocol does not provide error recovery and flow control and does not guarantee the reliability of the physical network.

**Internet router.** A device that enables an Internet Protocol host to act as a gateway for routing data between separate networks that use a specific adapter.

**IP address.** The 32-bit address defined by the Internet Protocol, standard 5, Request for Comment (RFC) 791. It is usually represented in dotted decimal notation.

**IP datagram.** In the Internet suite of protocols, the fundamental unit of information transmitted through an internet. It contains source and destination addresses, user data, and control information such as the length of the datagram, the header checksum, and flags indicating whether the datagram can be or has been fragmented.

**IP router.** A device in an IP internet that is responsible for making decisions about the paths over which network traffic will flow. Routing protocols are used to gain information about the network and to determine the best route over which the datagram should be forwarded toward the final destination. The datagrams are routed based on IP destination addresses.

## J

**job control language (JCL).** A control language used to identify a job to an operating system and to describe the job's requirements.

## K

**keyword.** The part of a command operand that consists of a specific character string (such as *DSNAME=*). See also *definition statement*.

## L

**LAN adapter.** The circuit card within a communicating device that, together with its associated software, enables the device to be attached to a LAN.

**LAN segment.** (1) Any portion of a LAN (for example, a bus or ring) that can operate independently, but that is connected to other parts of the network by means of bridges. (2) A ring or bus network without bridges.

**LEN node.** A node that supports independent LU protocols but does not support CP-CP sessions. It may be a peripheral node attached to a boundary node in a subarea network, an end node attached to an APPN network node in an APPN network, or a peer-connected node directly attached to another LEN node or APPN

end node. See also *low-entry networking (LEN) end node*.

**limited resource.** A connection facility that causes a session traversing it to be terminated if no session activity is detected for a specified period of time. See also *limited-resource session*.

**limited-resource session.** A session that traverses a limited-resource link. This session is terminated if no session activity is detected for a specified period of time.

**line group.** One or more telecommunication lines of the same type that can be activated and deactivated as a unit.

**line speed.** The number of binary digits that can be sent over a telecommunication line in one second, expressed in bits per second (bps).

**line switching.** Synonym for *circuit switching*.

**link.** The combination of the link connection (the transmission medium) and two link stations, one at each end of the link connection. A link connection can be shared among multiple links in a multipoint or Token-Ring configuration.

**link-attached.** Pertaining to devices that are connected to a controlling unit by a data link. Contrast with *channel-attached*. Synonymous with *remote*.

**link integrity verification tests (LIVT).** A set of operational procedures and messages that is defined by American National Standards Institute (ANSI) Standard T1.617 Annex D and International Telegraph and Telephone Consultative Committee (CCITT) Standard Q.933 Annex A and that is transferred over DLCI 0. This set of operational procedures and messages provides status and outage notification for frame-relay frame handler (FRFH) and frame-relay terminal equipment (FRTE) connections. See also *local management interface (LMI)*.

**link level.** A part of Recommendation X.25 that defines the link protocol used to get data into and out of the network across the full-duplex link connecting the subscriber's machine to the network node. LAP and LAPB are the link access protocols recommended by the CCITT. See *data link level*.

**Link Problem Determination Aid (LPDA).** A series of procedures that are used to test the status of and to control DCEs, the communication line, and the remote device interface. These procedures, or a subset of them, are implemented by host programs (such as the NetView program and VTAM), communication controller programs (such as NCP), and IBM LPDA DCEs. See also *LPDA-1* and *LPDA-2*.

**link station.** The hardware and software components within a node representing a connection to an adjacent node over a specific link. For example, if node A is the primary end of a multipoint line that connects to three adjacent nodes, node A will have three link stations representing the connections to the adjacent nodes. See also *adjacent link station*.

**LMI support.** A frame-relay support that exchanges line status information with adjacent nodes using local management interface (LMI) protocol. In NCP, the LMI support is the link-station support for the physical line.

**load module.** All or part of a computer program in a form suitable for loading into main storage for execution. A load module is usually the output of a linkage editor. (T)

**local.** Pertaining to a device accessed directly without use of a telecommunication line. Synonym for *channel-attached*.

**local area network (LAN).** (1) A computer network located on a user's premises within a limited geographical area. Communication within a local area network is not subject to external regulations; however, communication across the LAN boundary may be subject to some form of regulation. (T) (2) A network in which a set of devices are connected to one another for communication and that can be connected to a larger network. See also *Ethernet* and *Token Ring*. (3) Contrast with *wide area network (WAN)*.

**local management interface (LMI).** See *local management interface (LMI) protocol*.

**local management interface (LMI) protocol.** (1) In NCP, a set of frame-relay network management procedures and messages used by adjacent frame-relay nodes to exchange line status information over DLCI X'00'. NCP supports both the American National Standards Institute (ANSI) and International Telegraph and Telephone Consultative Committee (CCITT) versions of LMI protocol. These standards refer to LMI protocol as *link integrity verification tests (LIVT)*. (2) Originally, a set of frame-relay network management procedures and messages used by frame-relay nodes to exchange line status information over DLCI X'03FF' (1023). This protocol is defined in *Frame-Relay Specification with Extensions*, a document based on proposed T1S1 standards, which are copyrighted by Digital Equipment Corporation, Northern Telecom, Inc., and StrataCom, Inc. This protocol is not compatible with the ANSI or CCITT version. In this context, the term *local management interface* is a deprecated term for *link integrity verification tests (LIVT)*.

**locally administered address.** In a local area network, an adapter address that the user can assign to

## Glossary

override the universally administered address. Contrast with *universally administered address*.

**logical line.** The representation of the connection between NCP and a node communicating with NCP over a physical line such as Token-Ring or frame-relay. A single physical line can support multiple logical lines. Contrast with *physical line*.

**logical link.** A pair of link stations, one in each of two adjacent nodes, and their underlying link connection, providing a single link-layer connection between the two nodes. Multiple logical links can be distinguished while they share the use of the same physical media connecting two nodes. Examples are 802.2 logical links used on local area network (LAN) facilities and LAP E logical links on the same point-to-point physical link between two nodes. The term logical link also includes the multiple X.25 logical channels that share the use of the access link from a DTE to an X.25 network.

**logical link control (LLC).** The data link control (DLC) LAN sublayer that provides two types of DLC operation for the orderly exchange of information. The first type is connectionless service, which allows information to be sent and received without establishing a link. The LLC sublayer does not perform error recovery or flow control for connectionless service. The second type is connection-oriented service, which requires establishing a link prior to the exchange of information. Connection-oriented service provides sequenced information transfer, flow control, and error recovery.

**logical link control (LLC) protocol.** In a local area network, the protocol that governs the exchange of transmission frames between data stations independently of how the transmission medium is shared. (T)

**Note:** The LLC protocol was developed by the IEEE 802 committee and is common to all LAN standards.

**logical link control (LLC) protocol data unit.** A unit of information exchanged between link stations in different nodes. The LLC protocol data unit contains a destination service access point (DSAP), a source service access point (SSAP), a control field, and user data.

**logical unit (LU).** A type of network accessible unit that enables end users to gain access to network resources and communicate with each other.

**logical unit (LU) 6.2.** A type of logical unit that supports general communication between programs in a distributed processing environment. LU 6.2 is characterized by (a) a peer relationship between session partners, (b) efficient utilization of a session for multiple transactions, (c) comprehensive end-to-end error processing, and (d) a generic application program interface

(API) consisting of structured verbs that are mapped into a product implementation.

**logmode table.** Synonym for *logon mode table*.

**logon mode.** In VTAM, a subset of session parameters specified in a logon mode table for communication with a logical unit.

**logon mode table.** In VTAM, a set of entries for one or more logon modes. Each logon mode is identified by a logon mode name. Synonymous with *logmode table*.

**longitudinal parity check.** (1) A parity check on a row of binary digits that are members of a set forming a matrix; for example, a parity check on the bits of a track in a block on a magnetic tape. (T) (2) A system of error checking performed at the receiving station after a block check character has been accumulated. (3) Synonymous with longitudinal redundancy check.

**longitudinal redundancy check.** Synonymous with longitudinal parity check.

**low-entry networking (LEN).** A capability of nodes to attach directly to one another using basic peer-to-peer protocols to support multiple and parallel sessions between logical units.

**low-entry networking (LEN) end node.** A LEN node receiving network services from an adjacent APPN network node.

**low-entry networking (LEN) node.** A node that provides a range of end-user services, attaches directly to other nodes using peer protocols, and derives network services implicitly from an adjacent APPN network node, that is, without the direct use of CP-CP sessions.

**LPDA-1.** The first version of the Link Problem Determination Aid (LPDA) command set. LPDA-1 is not compatible with LPDA-2. See also *Link Problem Determination Aid (LPDA)* and *LPDA-2*.

**LPDA-2.** The second version of the LPDA command set. LPDA-2 provides all of the functions of LPDA-1; it also supports commands such as the following:

- DCE configuration
- Dial
- Set transmit speed
- Commands to operate a contact that can control external devices.

See also *Link Problem Determination Aid (LPDA)* and *LPDA-1*.

**LU-LU session.** A logical connection between two logical units (LUs) in an SNA network that typically provides communication between two end users.



## M

**maintenance and operator subsystem (MOSS).** A subsystem of an IBM communication controller, such as the 3725 or the 3720, that contains a processor and operates independently of the rest of the controller. It loads and supervises the controller, runs problem determination procedures, and assists in maintaining both hardware and software.

**maintenance and operator subsystem extended (MOSS-E).** A subsystem of the IBM 3745 Communication Controller that operates independently of the rest of the controller. It loads and supervises the controller, runs problem determination procedures, and assists in maintaining both hardware and software.

**major node.** In VTAM, a set of resources that can be activated and deactivated as a group. See *minor node*.

**mapping.** The process of converting data that is transmitted in one format by the sender into the data format that can be accepted by the receiver.

**mask.** (1) A pattern of characters used to control retention or elimination of portions of another pattern of characters. (I) (A) (2) To use a pattern of characters to control retention or elimination of portions of another pattern of characters. (I) (A)

**maximum transfer unit (MTU).** The maximum number of bytes that an Internet Protocol (IP) datagram can contain.

**maximum transmission unit (MTU).** In LANs, the largest possible unit of data that can be sent on a given physical medium in a single frame. For example, the MTU for Ethernet is 1500 bytes.

**Mb.** Megabit; 1 048 576 bits.

**MB.** Megabyte; 1 048 576 bytes.

**medium.** (1) A physical carrier of electrical energy. (2) A physical material in or on which data may be represented.

**medium access control (MAC).** In LANs, the sublayer of the data link control layer that supports medium-dependent functions and uses the services of the physical layer to provide services to the logical link control (LLC) sublayer. The MAC sublayer includes the method of determining when a device has access to the transmission medium.

**message switching.** The process of receiving a message, storing it, and forwarding it to its destination unaltered. (T)

**metric.** In Internet communications, a value, associated with a route, which is used to discriminate between multiple exit or entry points to the same autonomous system. The route with the lowest metric is preferred.

**microcode.** A code, representing the instructions of an instruction set, that is implemented in a part of storage that is not program-addressable.

**migration.** The installation of a new version or release of a program to replace an earlier version or release.

**minor node.** In VTAM, a uniquely defined resource within a major node. See *major node* and *node*.

**mixed-media multilink transmission group (MMMLTG).** See *transmission group (TG)*.

**modem (modulator/demodulator).** (1) A functional unit that modulates and demodulates signals. One of the functions of a modem is to enable digital data to be transmitted over analog transmission facilities. (T) (A) (2) A device that converts digital data from a computer to an analog signal that can be transmitted on a telecommunication line, and converts the analog signal received to data for the computer.

**modulo.** (1) Pertaining to a modulus; for example, 9 is equivalent to 4 modulo 5. (2) See also *modulus*.

**modulus.** A number, such as a positive integer, in a relationship that divides the difference between two related numbers without leaving a remainder; for example, 9 and 4 have a modulus of 5 ( $9 - 4 = 5$ ;  $4 - 9 = -5$ ; and 5 divides both 5 and -5 without leaving a remainder).

**multicast.** (1) Transmission of the same data to a selected group of destinations. (T) (2) A special form of broadcast where copies of the packet are delivered to a selected group of destinations. Contrast with *broadcast*.

**multidrop line.** Synonym for *multipoint line*.

**multilink transmission group (MLTG).** See *transmission group (TG)*.

**Multiple Virtual Storage (MVS).** See *MVS*.

**multipoint connection.** A connection established for data transmission among more than two data stations. (I) (A)

**Note:** The connection may include switching facilities.

**multipoint line.** A telecommunication line or circuit that connects two or more stations. Synonymous with *multidrop line*. Contrast with *point-to-point line*.

## Glossary

**multitailed.** Pertaining to a communication controller with an NCP attached to more than one host processor. See also *fanout*, *tailing*, and *twin-tailed*.

**MVS.** Multiple Virtual Storage. Implies MVS/ESA and OS/390.

**MVS/ESA product.** Multiple Virtual Storage/Enterprise Systems Architecture.

## N

**native network.** The subnetwork whose network identifier a node uses for its own network-qualified resource names.

**NCP connectionless SNA transport (NCST).** An NCP function that allows a communication controller to transfer data across the SNA subarea routing network using TCP/IP protocols. The NCST function causes LU 0 sessions to be established between NCST logical units in the NCP and between an NCST logical unit in the NCP and SNA network link (SNALINK) logical units in the host processors.

**NCP/EP definition facility (NDF).** A program that is part of System Support Programs (SSP) and that is used to generate a load module for a partitioned emulation program (PEP), a Network Control Program (NCP), or an Emulation Program (EP).

**NCP/Token-Ring interconnection (NTRI).** An NCP function that allows a communication controller to attach to the IBM Token-Ring Network and that provides both subarea and peripheral node data link control (DLC) services in the SNA network.

**negative response (NR).** In SNA, a response indicating that a request did not arrive successfully or was not processed successfully by the receiver. Contrast with *positive response*.

**NetView Performance Monitor (NPM).** An IBM licensed program that collects, monitors, analyzes, and displays data relevant to the performance of a VTAM telecommunication network. It runs as an online VTAM application program.

**NetView program.** An IBM licensed program used to monitor and manage a network and to diagnose network problems.

**network.** (1) An arrangement of nodes and connecting branches. (T) (2) A configuration of data processing devices and software connected for information interchange. (3) A group of nodes and the links interconnecting them.

**network accessible unit (NAU).** A logical unit (LU), physical unit (PU), control point (CP), or system ser-

vices control point (SSCP). It is the origin or the destination of information transmitted by the path control network. Synonymous with *network addressable unit*.

**network address.** (1) In a subarea network, an address, consisting of subarea and element fields, that identifies a link, link station, physical unit, logical unit, or system services control point. Subarea nodes use network addresses; peripheral nodes use local addresses or local-form session identifiers (LFSIDs). The boundary function in the subarea node to which a peripheral node is attached transforms local addresses or LFSIDs to network addresses and vice versa. Contrast with *network name*. (2) According to ISO 7498-3, a name, unambiguous within the OSI environment, that identifies a set of network service access points.

**network addressable unit (NAU).** Synonym for *network accessible unit*.

**network congestion.** An undesirable overload condition caused by traffic in excess of what a network can handle.

**network control mode.** The mode in which a network control program can direct a communication controller to perform such activities as polling, device addressing, dialing, and answering. See also *emulation mode*.

**network control program.** A program, generated by the user from a library of IBM-supplied modules, that controls the operation of a communication controller.

**Network Control Program (NCP).** An IBM licensed program that provides communication controller support for single-domain, multiple-domain, and interconnected network capability.

**network identifier.** (1) In TCP/IP, that part of the Internet address that defines a network. The length of the network ID depends on the type of network class (A, B, or C). (2) A 1- to 8-byte customer-selected name or an 8-byte IBM-registered name that uniquely identifies a specific subnetwork.

**network management vector transport (NMVT).** A management services request/response unit (RU) that flows over an active session between physical unit management services and control point management services (SSCP-PU session).

**network name.** The symbolic identifier by which end users refer to a network accessible unit, a link, or a link station within a given subnetwork. In APPN networks, network names are also used for routing purposes. Contrast with *network address*.

**network node (NN).** Synonym for *Advanced Peer-to-Peer Networking (APPN) network node*.

**network performance analyzer (NPA).** A function of NCP that collects performance data about devices. The data is recorded by NPM.

**Network Routing Facility (NRF).** An IBM licensed program that resides in NCP. NRF provides a path for routing messages between terminals and routes messages over this path without going through the host processor.

**network session accounting (NSA).** The NetView Performance Monitor (NPM) subsystem that receives session accounting information from the NCP for sessions that flow throughout a network.

**Network Terminal Option (NTO).** An IBM licensed program, used in conjunction with NCP, that allows certain non-SNA devices to participate in sessions with SNA application programs in the host processor. When data is sent from a non-SNA device to the host processor, NTO converts non-SNA protocol to SNA protocol; and when data is sent from the host processor to the non-SNA device, NTO converts SNA protocol to non-SNA protocol.

**node.** (1) In a network, a point at which one or more functional units connect channels or data circuits. (I) (2) Any device, attached to a network, that transmits and receives data. (3) An endpoint of a link or a junction common to two or more links in a network. Nodes can be processors, communication controllers, cluster controllers, or terminals. Nodes can vary in routing and other functional capabilities. (4) In VTAM, a point in a network defined by a symbolic name. See *major node* and *minor node*.

**node name.** In VTAM, the symbolic name assigned to a specific major or minor node during network definition.

**node type.** A designation of a node according to the protocols it supports or the role it plays in a network. Node type was originally denoted numerically (as 1, 2.0, 2.1, 4, and 5) but is now characterized more specifically by protocol type (APPN network node, LEN node, subarea node, and interchange node, for example) because type 2.1 nodes and type 5 nodes support multiple protocol types and roles.

**Non-SNA Interconnection (NSI).** An IBM licensed program that provides format identification (FID) support for selected non-SNA facilities. Thus, it allows SNA and non-SNA facilities to share SDLC links. It also allows the remote concentration of selected non-SNA devices along with SNA devices.

**nonswitched connection.** A connection that does not have to be established by dialing. Contrast with *switched connection*.

**nonswitched line.** A telecommunication line on which connections do not have to be established by dialing. Contrast with *switched line*.

**notification.** An unscheduled, spontaneously generated report of an event that has occurred.

**NPDA.** (1) Network Problem Determination Application. (2) A command that starts the NetView hardware monitor. NPDA also identifies various panels and functions as part of the hardware monitor.

**NTuneMON.** A program that runs with the NetView program and monitors NCPs that were activated by the VTAM on the host where NTuneMON is running.

**NTuneNCP.** A feature of NTuneMON that runs in a communication controller and, with VTAM, enables a network administrator to tune NCP interactively.

## O

**operating system (OS).** Software that controls the execution of programs and that may provide services such as resource allocation, scheduling, input/output control, and data management. Although operating systems are predominantly software, partial hardware implementations are possible. (T)

**outboard data link control (ODLC).** (1) Data link control (DLC) processing performed by a coprocessor. (2) In NCP, data link control (DLC) processing performed by the 3746 Model 900 connectivity subsystem (CSS). (3) For the IBM 6611 Network Processor, data link control (DLC) processing performed by a deep adapter.

**outbound.** In communications, data that is transmitted to the network.

## P

**padding.** A technique by which a receiving component controls the rate of transmission of a sending component to prevent overrun or congestion. See *session-level padding*, *send padding*, and *virtual route (VR) padding*. See also *flow control*.

**padding window.** (1) The path information units (PIUs) that can be transmitted on a virtual route before a virtual-route padding response is received, indicating that the virtual route receiver is ready to receive more PIUs on the route. (2) The requests that can be transmitted on the normal flow in one direction on a session before a session-level padding response is received, indicating that the receiver is ready to accept the next group of requests.

## Glossary

**packet.** (1) In data communication, a sequence of binary digits, including data and control signals, that is transmitted and switched as a composite whole. The data, control signals, and, possibly, error control information are arranged in a specific format. (l) (2) In X.25, a data transmission information unit. A group of data and control characters, transferred as a unit, determined by the process of transmission. Commonly used data field lengths in packets are 128 or 256 bytes. (3) The field structure and format defined in CCITT X.25 Recommendation.

**packet switching.** The process of routing and transferring data by means of addressed packets so that a channel is occupied only during transmission of a packet. On completion of the transmission, the channel is made available for transfer of other packets. (l)

**parallel links.** In SNA, two or more links between adjacent subarea nodes.

**parallel sessions.** Two or more concurrently active sessions between the same two network accessible units (NAUs) using different pairs of network addresses or local-form session identifiers. Each session can have independent session parameters.

**parallel transmission groups.** Multiple transmission groups between adjacent nodes, with each group having a distinct transmission group number.

**partitioned data set (PDS).** A data set in direct access storage that is divided into partitions, called members, each of which can contain a program, part of a program, or data.

### **partitioned emulation programming (PEP)**

**extension.** A function of a network control program that enables a communication controller to operate some telecommunication lines in network control mode while simultaneously operating others in emulation mode.

**path.** (1) In a network, any route between any two nodes. A path may include more than one branch. (T) (2) The series of transport network components (path control and data link control) that are traversed by the information exchanged between two network accessible units. See also *explicit route (ER)*, *route extension*, and *virtual route (VR)*. (3) In VTAM when defining a switched major node, a potential dial-out port that can be used to reach that node. (4) In the NetView/PC program, a complete line in a configuration that contains all of the resources in the service point command service (SPCS) query link configuration request list.

**path control (PC).** The function that routes message units between network accessible units in the network and provides the paths between them. It converts the basic information units (BIUs) from transmission control

(possibly segmenting them) into path information units (PIUs) and exchanges basic transmission units containing one or more PIUs with data link control. Path control differs by node type: some nodes (APPN nodes, for example) use locally generated session identifiers for routing, and others (subarea nodes) use network addresses for routing.

**path information unit (PIU).** A message unit consisting of a transmission header (TH) alone, or a TH followed by a basic information unit (BIU) or a BIU segment. See also *transmission header*.

**peer.** In network architecture, any functional unit that is in the same layer as another entity. (T)

**peripheral border node.** A border node that interconnects adjacent APPN networks having different network identifiers in order to support LU-LU sessions that have one partner LU in its native network. Contrast with *extended border node*.

**peripheral host node.** A node that provides an application program interface (API) for running application programs but does not provide SSCP functions and is not aware of the network configuration. The peripheral host node does not provide subarea node services. It has boundary function provided by its adjacent subarea. See *boundary node*, *host node*, *node*, *peripheral node*, *subarea host node*, and *subarea node*. See also *boundary function* and *node type*.

**peripheral link.** In SNA, a link between a subarea and a peripheral node. See also *route extension (REX)*.

**peripheral logical unit (LU).** In SNA, a logical unit in a peripheral node.

**peripheral node.** A node that uses local addresses for routing and therefore is not affected by changes in network addresses. A peripheral node requires boundary-function assistance from an adjacent subarea node. A peripheral node can be a type 1, 2.0, or 2.1 node connected to a subarea boundary node.

**peripheral PU.** In SNA, a physical unit (PU) in a peripheral node.

**permanent virtual circuit (PVC).** (1) In X.25 and frame-relay communications, a virtual circuit that has a logical channel permanently assigned to it at each data terminal equipment (DTE). Call-establishment protocols are not required. Contrast with *switched virtual circuit (SVC)*. (2) The logical connection between two frame-relay terminating equipment stations, either directly or through one or more frame-relay frame handlers. A PVC consists of one or more PVC segments.

**physical line.** The physical connection between NCP and an adjacent device or local area network (LAN). A single physical line, such as Token-Ring or frame-relay,

can support multiple logical lines. Contrast with *logical line*.

**physical unit (PU).** The component that manages and monitors the resources (such as attached links and adjacent link stations) associated with a node, as requested by an SSCP via an SSCP-PU session. An SSCP activates a session with the physical unit in order to indirectly manage, through the PU, resources of the node such as attached links. This term applies to type 2.0, type 4, and type 5 nodes only. See also *peripheral PU* and *subarea PU*.

**physical unit (PU) services.** In SNA, the components within a physical unit (PU) that provide configuration services and maintenance services for SSCP-PU sessions. See also *logical unit (LU) services*.

**physical unit type.** In SNA, the classification of a physical unit (PU) according to the type of node in which it resides. The physical unit type is the same as its node type; that is, a type 1 physical unit resides in a type 1 node, and so forth.

**point-to-point connection.** A connection established between two data stations for data transmission. (I) (A)

**Note:** The connection may include switching facilities.

**point-to-point line.** A switched or nonswitched telecommunication line that connects a single remote station to a computer. Contrast with *multipoint line*.

**polling.** (1) On a multipoint connection or a point-to-point connection, the process whereby data stations are invited, one at a time, to transmit. (I) (2) Interrogation of devices for such purposes as to avoid contention, to determine operational status, or to determine readiness to send or receive data. (A)

**port.** (1) An access point for data entry or exit. (2) A connector on a device to which cables for other devices such as display stations and printers are attached. Synonymous with *socket*. (3) The representation of a physical connection to the link hardware. A port is sometimes referred to as an adapter; however, there can be more than one port on an adapter. There may be one or more ports controlled by a single DLC process. (4) In the Internet suite of protocols, a 16-bit number used to communicate between TCP or the User Datagram Protocol (UDP) and a higher-level protocol or application. Some protocols, such as File Transfer Protocol (FTP) and Simple Mail Transfer Protocol (SMTP), use the same well-known port number in all TCP/IP implementations. (5) An abstraction used by transport protocols to distinguish among multiple destinations within a host machine.

**port number.** In Internet communications, the identification of an application entity to the transport service.

**positive response.** In SNA, a response indicating that a request was received and processed. Contrast with *negative response*.

**primary logical unit (PLU).** In SNA, the logical unit (LU) that sends the BIND to activate a session with its partner LU. Contrast with *secondary logical unit*.

**primary route.** In NCP frame relay, the internal PVC segment between the two primary frame handler subports in a subport set. Contrast with *substitute route*.

**primary session.** An extended recovery facility (XRF) session between the active application subsystem and a terminal user.

**problem determination.** The process of determining the source of a problem; for example, a program component, machine failure, telecommunication facilities, user or contractor-installed programs or equipment, environmental failure such as a power loss, or user error.

**procedure-correlation identifier (PCID).** In SNA, a value used to correlate all requests and replies associated with a given procedure.

**protocol.** (1) A set of semantic and syntactic rules that determine the behavior of functional units in achieving communication. (I) (2) In Open Systems Interconnection architecture, a set of semantic and syntactic rules that determine the behavior of entities in the same layer in performing communication functions. (T) (3) In SNA, the meanings of, and the sequencing rules for, requests and responses used for managing the network, transferring data, and synchronizing the states of network components.

**PU type.** (1) Deprecated term for *node type*. (2) The type of physical unit in a node.

**PVC segment.** The connection between two frame-relay subports that may pass through a frame-relay network.

## Q

**queue.** (1) A list constructed and maintained so that the next data element to be retrieved is the one stored first. (T) (2) A line or list of items waiting to be processed; for example, work to be performed or messages to be displayed. (3) To arrange in or form a queue.

## Glossary

### R

**read-only memory (ROM).** Memory in which stored data cannot be modified by the user except under special conditions.

**receive not ready (RNR).** In communications, a data link command or response that indicates a temporary condition of being unable to accept incoming frames.

**receive pacing.** In SNA, the pacing of message units being received by a component. See also *send pacing*.

**record.** (1) In programming languages, an aggregate that consists of data objects, possibly with different attributes, that usually have identifiers attached to them. In some programming languages, records are called structures. (I) (2) A set of data treated as a unit. (T) (3) A set of one or more related data items grouped for processing. (4) In VTAM, the unit of data transmission for record mode. A record represents whatever amount of data the transmitting node chooses to send.

**record maintenance statistics (RECMS).** An SNA error event record built from an NCP or line error and sent unsolicited to the host.

**redefinable line.** A line that is in use and can be activated (defined using the USE keyword on the LINE definition statement). It can be changed to a spare line using NTuneMON with NTuneNCP.

**remote.** Pertaining to a system, program, or device that is accessed through a telecommunication line. Contrast with *local*. Synonym for *link-attached*.

**remote host.** Any host on a network except the host at which a particular operator is working.

**request for maintenance statistics (REQMS).** A host solicitation to an SNA controller for a statistical data record.

**request header (RH).** The control information that precedes a request unit (RU). See also *request/response header (RH)*.

**request unit (RU).** A message unit that contains control information, end-user data, or both.

**request/response header (RH).** Control information associated with a particular RU. The RH precedes the request/response unit (RU) and specifies the type of RU (request unit or response unit).

**request/response unit (RU).** A generic term for a request unit or a response unit. See *request unit (RU)* and *response unit (RU)*.

**reset.** On a virtual circuit, reinitialization of data flow control. At reset, all data in transit are eliminated.

**resource resolution table (RRT).** In NPM, this table contains the names of network resources for which data is to be collected. The NPM RRT corresponds with an NCP and is built by NPMGEN from an NCP Stage I and an NCP RRT.

**response header (RH).** A header, optionally followed by a response unit (RU), that indicates whether the response is positive or negative and that may contain a pacing response. See also *negative response*, *pacing response*, and *positive response*.

**response time.** (1) The elapsed time between the end of an inquiry or demand on a computer system and the beginning of the response; for example, the length of time between an indication of the end of an inquiry and the display of the first character of the response at a user terminal. (I) (A) (2) For response time monitoring, the time from the activation of a transaction until a response is received, according to the response time definition coded in the performance class.

**response unit (RU).** A message unit that acknowledges a request unit. It may contain prefix information received in a request unit. If positive, the response unit may contain additional information (such as session parameters in response to BIND SESSION). If negative, the response unit contains sense data defining the exception condition.

**ring.** See *ring network*.

**ring network.** (1) A network in which every node has exactly two branches connected to it and in which there are exactly two paths between any two nodes. (T) (2) A network configuration in which devices are connected by unidirectional transmission links to form a closed path.

**ring segment.** A section of a ring that can be isolated (by unplugging connectors) from the rest of the ring. See *LAN segment*.

**ring station.** The functions necessary for connecting to the local area network and for operating with the Token-Ring protocols. These include token handling, transferring copied frames from the ring to the using node's storage, maintaining error counters, observing Medium Access Control (MAC) sublayer protocols (for address acquisition, error reporting, or other duties), and (in the full-function native mode) directing frames to the correct Data Link Control link station. A ring station is an instance of a MAC sublayer in a node attached to a ring.

**route.** (1) An ordered sequence of nodes and transmission groups (TGs) that represent a path from an

origin node to a destination node traversed by the traffic exchanged between them. (2) The path that network traffic uses to get from source to destination.

**route extension (REX).** In SNA, the path control network components, including a peripheral link, that make up the portion of a path between a subarea node and a network addressable unit (NAU) in an adjacent peripheral node. See also *explicit route (ER)*, *path*, and *virtual route (VR)*.

**Route Table Generator (RTG).** An IBM-supplied field developed program that assists the user in generating path tables for SNA networks.

**router.** (1) A computer that determines the path of network traffic flow. The path selection is made from several paths based on information obtained from specific protocols, algorithms that attempt to identify the shortest or best path, and other criteria such as metrics or protocol-specific destination addresses. (2) An attaching device that connects two LAN segments, which use similar or different architectures, at the reference model network layer. Contrast with *bridge* and *gateway*. (3) In OSI terminology, a function that determines a path by which an entity can be reached.

**routing.** (1) The process of determining the path to be used for transmission of a message over a network. (T) (2) The assignment of the path by which a message is to reach its destination. (3) In SNA, the forwarding of a message unit along a particular path through a network, as determined by parameters carried in the message unit, such as the destination network address in a transmission header.

**Routing Information Protocol (RIP).** In the Internet suite of protocols, an interior gateway protocol used to exchange intradomain routing information and to determine optimum routes between internet hosts. RIP determines optimum routes on the basis of route metrics, not link transmission speed.

**routing table.** A collection of routes used to direct datagram forwarding or to establish a connection. The information is passed among routers to identify network topology and destination feasibility.

**RU chain.** In SNA, a set of related request/response units (RUs) that are consecutively transmitted on a particular normal or expedited data flow. The request RU chain is the unit of recovery: if one of the RUs in the chain cannot be processed, the entire chain is discarded. Each RU belongs to only one chain, which has a beginning and an end indicated by means of control bits in request/response headers within the RU chain. Each RU can be designated as first-in-chain (FIC), last-in-chain (LIC), middle-in-chain (MIC), or only-in-chain (OIC). Response units and expedited-flow request units are always sent as only-in-chain.

## S

**scanner.** (1) A device that examines a spatial pattern one part after another, and generates analog or digital signals corresponding to the pattern. Scanners are often used in mark sensing, pattern recognition, or character recognition. (I) (A) (2) For the 3725 communication controller, a processor dedicated to controlling a small number of telecommunication lines. It provides the connection between the line interface coupler hardware and the central control unit.

**scanner interface trace (SIT).** A record of the activity within the communication scanner processor (CSP) for a specified data link between an IBM 3725 Communication Controller and a resource.

**secondary logical unit (SLU).** In SNA, the logical unit (LU) that contains the secondary half-session for a particular LU-LU session. An LU may contain secondary and primary half-sessions for different active LU-LU sessions. Contrast with *primary logical unit (PLU)*.

**secondary logical unit (SLU) key.** A key-encrypting key used to protect a session cryptography key during its transmission to the secondary half-session.

**segment.** (1) In the IBM Token-Ring Network, a section of cable between components or devices. A segment may consist of a single patch cable, several patch cables that are connected, or a combination of building cable and patch cables that are connected. (2) In Internet communications, the unit of transfer between TCP functions in different machines. Each segment contains control and data fields; the current byte stream position and actual data bytes are identified along with a checksum to validate received data.

**segmenting.** In OSI, a function performed by a layer to map one protocol data unit (PDU) from the layer it supports into multiple PDUs.

**send pacing.** In SNA, pacing of message units that a component is sending. See also *receive pacing*.

**server.** (1) A functional unit that provides shared services to workstations over a network; for example, a file server, a print server, a mail server. (T) (2) In a network, a data station that provides facilities to other stations; for example, a file server, a print server, a mail server. (A)

**service access point (SAP).** (1) In Open Systems Interconnection (OSI) architecture, the point at which the services of a layer are provided by an entity of that layer to an entity of the next higher layer. (T) (2) A logical point made available by an adapter where information can be received and transmitted. A single

## Glossary

service access point can have many links terminating in it.

**session.** (1) In network architecture, for the purpose of data communication between functional units, all the activities which take place during the establishment, maintenance, and release of the connection. (T) (2) A logical connection between two network accessible units (NAUs) that can be activated, tailored to provide various protocols, and deactivated, as requested. Each session is uniquely identified in a transmission header (TH) accompanying any transmissions exchanged during the session.

**session activation request.** In SNA, a request that activates a session between two network accessible units (NAUs) and specifies session parameters that control various protocols during session activity; for example, BIND and ACTPU. Contrast with *session deactivation request*.

**session control (SC).** In SNA, either of the following:

- One of the components of transmission control. Session control is used to purge data flowing in a session after an unrecoverable error occurs, to resynchronize the data flow after such an error, and to perform cryptographic verification.
- A request unit (RU) category used for requests and responses exchanged between the session control components of a session and for session activation and deactivation requests and responses.

**session data.** Data about a session, collected by the NetView program, that consists of session awareness data, session trace data, and session response time data.

**session deactivation request.** In SNA, a request that deactivates a session between two network accessible units (NAUs); for example, UNBIND and DACTPU. Synonymous with *generic unbind*. Contrast with *session activation request*.

**session-level pacing.** A flow control technique that permits a receiving half-session or session connector to control the data transfer rate (the rate at which it receives request units) on the normal flow. It is used to prevent overloading a receiver with unprocessed requests when the sender can generate requests faster than the receiver can process them. See *pacing* and *virtual route pacing*.

**session limit.** (1) The maximum number of concurrently active LU-LU sessions that a particular logical unit (LU) can support. (2) In NCP, the maximum number of concurrent line-scheduling sessions on a non-SDLC, multipoint line.

**session partner.** In SNA, one of the two network accessible units (NAUs) having an active session.

**shared.** Pertaining to the availability of a resource for more than one use at the same time.

**shutdown.** The process of ending operation of a system or a subsystem, following a defined procedure.

**SNA network.** The part of a user-application network that conforms to the formats and protocols of Systems Network Architecture. It enables reliable transfer of data among end users and provides protocols for controlling the resources of various network configurations. The SNA network consists of network accessible units (NAUs), boundary function, gateway function, and intermediate session routing function components; and the transport network.

**SNA network interconnection (SNI).** The connection, by gateways, of two or more independent SNA networks to allow communication between logical units in those networks. The individual SNA networks retain their independence.

**SNA Network Link (SNALINK).** A function of the TCP/IP products for VM and MVS that allows the use of an SNA subarea routing network to transfer data using TCP/IP protocols. SNALINK provides the interface between TCP/IP and the SNA network. SNALINK must be defined as an application program to VTAM, which causes LU 0 sessions to be established between the SNALINK logical unit and other logical units in the SNA network.

**snap.** See *snapshot program*.

**snapshot program.** A trace program that produces output data only for selected instructions or for selected conditions. (I) (A)

**softcopy.** (1) A nonpermanent copy of the contents of storage in the form of a display image. (T) (2) One or more files that can be electronically distributed, manipulated, and printed by a user. Contrast with *hardcopy*.

**solicited message.** A response from VTAM to a command entered by a program operator. Contrast with *unsolicited message*.

**source service access point (SSAP).** In SNA and TCP/IP, a logical address that allows a system to send data to a remote device from the appropriate communications support. Contrast with *destination service access point (DSAP)*.

**span.** In the NetView program, a user-defined group of network resources within a single domain. Each major or minor node is defined as belonging to one or more spans. See also *span of control*.

**span of control.** The total network resources over which a particular network operator has control. All the



network resources listed in spans associated through profile definition with a particular network operator are within that operator's span of control.

**spare line.** A line that is not in use and cannot be activated (defined using the USE keyword on the LINE definition statement). It can be changed to a redefinable line using NTuneMON with NTuneNCP, and then activated.

**SSCP ID.** In SNA, a number that uniquely identifies a system services control point (SSCP). The SSCP ID is used in session activation requests sent to physical units (PUs) and other SSCPs.

**SSCP-independent LU.** An LU that is able to activate an LU-LU session (that is, send a BIND request) without assistance from an SSCP. It does not have an SSCP-LU session. Currently, only an LU 6.2 can be an independent LU.

**SSCP-LU session.** In SNA, a session between a system services control point (SSCP) and a logical unit (LU). The session enables the LU to request the SSCP to help initiate LU-LU sessions.

**SSCP monitor mode function (SMMF).** A function within NCP that keeps NCP resources active when an external SSCP has not established ownership of NCP.

**SSCP-PU session.** In SNA, a session between a system services control point (SSCP) and a physical unit (PU); SSCP-PU sessions allow SSCPs to send requests to and receive status information from individual nodes in order to control the network configuration.

**start-stop (SS) transmission.** (1) Asynchronous transmission such that each group of signals representing a character is preceded by a start signal and is followed by a stop signal. (T) (A) (2) Asynchronous transmission in which a group of bits is (a) preceded by a start bit that prepares the receiving mechanism for the reception and registration of a character, and (b) followed by at least one stop bit that enables the receiving mechanism to come to an idle condition pending reception of the next character. See also *binary synchronous transmission* and *synchronous data link control*.

**static.** (1) In programming languages, pertaining to properties that can be established before execution of a program; for example, the length of a fixed length variable is static. (I) (2) Pertaining to an operation that occurs at a predetermined or fixed time. (3) Contrast with *dynamic*.

**station.** An input or output point of a system that uses telecommunication facilities; for example, one or more systems, computers, terminals, devices, and associated programs at a particular location that can send or receive data over a telecommunication line.

**status.** The condition or state of hardware or software, usually represented by a status code.

**stream.** (1) To send data from one device to another. (2) See *data stream*.

**subarea.** A portion of the SNA network consisting of a subarea node, attached peripheral nodes, and associated resources. Within a subarea node, all network accessible units (NAUs), links, and adjacent link stations (in attached peripheral or subarea nodes) that are addressable within the subarea share a common subarea address and have distinct element addresses.

**subarea address.** A value in the subarea field of the network address that identifies a particular subarea. See also *element address*.

**subarea host node.** A host node that provides both subarea function and an application program interface (API) for running application programs. It provides system services control point (SSCP) functions and subarea node services, and it is aware of the network configuration. See *boundary node*, *communication management configuration host node*, *data host node*, *host node*, *node*, *peripheral node*, and *subarea node*. See also *boundary function* and *node type*.

**subarea link.** In SNA, a link that connects two subarea nodes. See *channel link* and *link*.

**subarea network.** Interconnected subareas, their directly attached peripheral nodes, and the transmission groups that connect them.

**subarea node (SN).** A node that uses network addresses for routing and maintains routing tables that reflect the configuration of the network. Subarea nodes can provide gateway function to connect multiple subarea networks, intermediate routing function, and boundary function support for peripheral nodes. Type 4 and type 5 nodes can be subarea nodes.

**subarea path control.** The function in a subarea node that routes message units between network accessible units (NAUs) and provides the paths between them. See *path control* and *peripheral path control*. See also *boundary function*, *peripheral node*, and *subarea node*.

**subarea PU.** In SNA, a physical unit (PU) in a subarea node.

**subnet.** (1) In TCP/IP, a part of a network that is identified by a portion of the Internet address. (2) Synonym for *subnetwork*.

**subnet mask.** Synonym for *address mask*.

**subnetwork.** (1) Any group of nodes that have a set of common characteristics, such as the same network

## Glossary

ID. (2) In the AIX operating system, one of a group of multiple logical network divisions of another network, such as can be created by the Transmission Control Protocol/Internet Protocol (TCP/IP) interface program. (3) Synonymous with *subnet*.

**subnetwork mask.** Synonym for *address mask*.

**suboperand.** In NCP, one of multiple elements in a keyword value. See also *definition statement* and *keyword*.

**support.** (1) An access point for data entry or exit over a logical connection. The relationship between the physical line and the port is analogous to the relationship between the logical connection and the support. (2) In a frame-relay network, the representation of a logical connection on a frame-relay physical line and the point where the logical connection attaches to the frame-relay frame handler (FRFH). Each support on a physical line has a unique data link connection identifier (DLCI) and can represent an FRTE, FRFH, or LMI connection. See *frame handler support (FHSP)* and *terminal equipment support*.

**support set.** In NCP, a set of frame handler supports linked by internal PVC segments. A support set consists of two primary frame handler supports and an optional substitute frame handler support for each primary.

**substitute route.** In NCP frame relay, an internal PVC segment between a primary frame handler support and a substitute frame handler support in a support set. Contrast with *primary route*. See also *substitute support*.

**substitute support.** In NCP, a frame handler support in a support set that is used when a primary frame handler support in the set is not available.

**subsystem.** A secondary or subordinate system, usually capable of operating independently of, or asynchronously with, a controlling system. (T)

**subvector.** A subcomponent of the NMVT major vector.

**supervisor call (SVC).** A request that serves as the interface into operating system functions, such as allocating storage. The SVC protects the operating system from inappropriate user entry. All operating system requests must be handled by SVCs.

**switchback.** In an IBM 3745 Communication Controller with twin central control units (CCUs) in backup mode, the process by which, after fallback, buses are moved back to the central control unit (CCU) that originally operated them.

**switched connection.** (1) A mode of operating a data link in which a circuit or channel is established to switching facilities as, for example, in a public switched network. (T) (2) A connection established by dialing. Contrast with *nonswitched connection*.

**switched line.** A telecommunication line in which the connection is established by dialing. Contrast with *nonswitched line*.

**switched major node.** In VTAM, a major node whose minor nodes are physical units and logical units attached by switched SDLC links.

**switched network.** Any network in which connections are established by closing switches, for example, by dialing.

**switched network backup (SNBU).** An optional facility that allows a user to specify, for certain types of physical units (PUs), a switched line to be used as an alternate path if the primary line becomes unavailable or unusable.

**switched virtual circuit (SVC).** An X.25 circuit that is dynamically established when needed. The X.25 equivalent of a switched line.

**synchronous.** (1) Pertaining to two or more processes that depend upon the occurrence of specific events such as common timing signals. (T) (2) Occurring with a regular or predictable time relationship.

**Synchronous Data Link Control (SDLC).** A discipline conforming to subsets of the Advanced Data Communication Control Procedures (ADCCP) of the American National Standards Institute (ANSI) and High-level Data Link Control (HDLC) of the International Organization for Standardization, for managing synchronous, code-transparent, serial-by-bit information transfer over a link connection. Transmission exchanges may be duplex or half-duplex over switched or nonswitched links. The configuration of the link connection may be point-to-point, multipoint, or loop. (I) Contrast with *binary synchronous communication (BSC)*.

**system services control point (SSCP).** A component within a subarea network for managing the configuration, coordinating network operator and problem determination requests, and providing directory services and other session services for end users of the network. Multiple SSCPs, cooperating as peers with one another, can divide the network into domains of control, with each SSCP having a hierarchical control relationship to the physical units and logical units within its own domain.

**System Support Programs (SSP).** An IBM licensed program, made up of a collection of utilities and small programs, that supports the operation of the NCP.

**Systems Network Architecture (SNA).** The description of the logical structure, formats, protocols, and operational sequences for transmitting information units through, and controlling the configuration and operation of, networks. The layered structure of SNA allows the ultimate origins and destinations of information, that is, the end users, to be independent of and unaffected by the specific SNA network services and facilities used for information exchange.

## T

**tailing.** A feature on a multichannel modem that allows another modem link to be attached to one of the channels. See also *fanout*, *multitailed*, and *twin-tailed*.

**takeover.** The process by which the failing active subsystem is released from its extended recovery facility (XRF) sessions with terminal users and replaced by an alternate subsystem. See *resource takeover*.

**TAP.** Synonym for *ACF/TAP*.

**task.** In a multiprogramming or multiprocessing environment, one or more sequences of instructions treated by a control program as an element of work to be accomplished by a computer. (I) (A)

**TCAM.** Synonym for *ACF/TCAM*.

**telecommunication line.** (1) The portion of a data circuit external to a data circuit-terminating equipment (DCE) that connects the DCE to a data-switching exchange (DSE), that connects a DCE to one or more other DCEs, or that connects a DSE to another DSE. (T) (2) Any physical medium, such as a wire or microwave beam, that is used to transmit data. Synonymous with *transmission line*.

**Telecommunications Access Method (TCAM).** An access method used to transfer data between main storage and remote or local terminals.

**teletypewriter exchange service (TWX).** Teletypewriter service in which suitably arranged teletypewriter stations are provided with lines to a central office for access to other such stations throughout the U.S. and Canada. Both baudot- and ASCII-coded machines are used. Business machines may also be used, with certain restrictions.

**terminal.** A device, usually equipped with a keyboard and a display device, that is capable of sending and receiving information.

**terminal equipment subport.** A subport that serves as a termination point on a virtual circuit.

**terminating equipment subport (TESP).** The endpoint of a frame-relay permanent virtual circuit

(PVC); the point at which frame-relay terminating equipment has access to the PVC. A TESP provides higher-level functions with access to a frame-relay physical line. Each TESP in a single frame-relay port has a unique data link connection identifier (DLCI). Contrast with *frame handler subport*.

**threshold.** (1) In the NetView program, a percentage value, set for a resource and compared to a calculated error-to-traffic ratio. (2) In NPM, high or low values supplied by the user to monitor data and statistics being collected. (3) In IBM bridge programs, a value set for the maximum number of frames that are not forwarded across a bridge due to errors, before a "threshold exceeded" occurrence is counted and indicated to network management programs. (4) An initial value from which a counter is decremented to 0, or a value to which a counter is incremented or decremented from an initial value.

**Time Sharing Option (TSO).** An operating system option; for the System/370 system, the option provides interactive time sharing from remote terminals.

**timeout.** (1) An event that occurs at the end of a predetermined period of time that began at the occurrence of another specified event. (I) (2) A time interval allotted for certain operations to occur; for example, response to polling or addressing before system operation is interrupted and must be restarted.

**token.** (1) In a local area network, the symbol of authority passed successively from one data station to another to indicate the station temporarily in control of the transmission medium. Each data station has an opportunity to acquire and use the token to control the medium. A token is a particular message or bit pattern that signifies permission to transmit. (T) (2) In LANs, a sequence of bits passed from one device to another along the transmission medium. When the token has data appended to it, it becomes a frame.

**Token Ring.** (1) According to IEEE 802.5, network technology that controls media access by passing a token (special packet or frame) between media-attached stations. (2) A FDDI or IEEE 802.5 network with a ring topology that passes tokens from one attaching ring station (node) to another. (3) See also *local area network (LAN)*.

**Token-Ring interface coupler (TIC).** An adapter that can connect a 3720, 3725, or 3745 Communication Controller to an IBM Token-Ring Network.

**Token-Ring network.** (1) A ring network that allows unidirectional data transmission between data stations, by a token passing procedure, such that the transmitted data return to the transmitting station. (T) (2) A network that uses a ring topology, in which tokens are passed in a circuit from node to node. A node that is ready to

## Glossary

send can capture the token and insert data for transmission.

**topology.** In communications, the physical or logical arrangement of nodes in a network, especially the relationships among nodes and the links between them.

**trace.** (1) A record of the execution of a computer program. It exhibits the sequences in which the instructions were executed. (A) (2) For data links, a record of the frames and bytes transmitted or received.

**Trace Analysis Program (TAP).** Synonym for *Advanced Communications Function for the Trace Analysis Program (ACF/TAP)*.

**Transaction Processing Facility (TPF).** A high-availability, high-performance system, designed to support real-time, transaction driven applications. The specialized architecture of TPF is intended to optimize system efficiency, reliability, and responsiveness for data communication and database processing. TPF provides real-time inquiry and update to a large, centralized database, where message length is relatively short in both directions, and response time is generally less than three seconds. Formerly known as the Airline Control Program/Transaction Processing Facility (ACP/TPF).

**translation table.** A table used to replace one or more characters with alternative characters; for example, to translate characters representing a virtual address to those representing a real address, characters representing an event to those representing a procedure call, characters of a national character set to those of another national language, or characters representing a relocated address to those representing an absolute address.

**Transmission Control Protocol (TCP).** A communications protocol used in Internet and in any network that follows the U.S. Department of Defense standards for internetwork protocol. TCP provides a reliable host-to-host protocol between hosts in packet-switched communications networks and in interconnected systems of such networks. It assumes that the Internet protocol is the underlying protocol.

**Transmission Control Protocol/Internet Protocol (TCP/IP).** A set of communications protocols that support peer-to-peer connectivity functions for both local and wide area networks.

**transmission control unit (TCU).** A communication control unit whose operations are controlled solely by programmed instructions from the computing system to which the unit is attached. No program is stored or executed in the unit. Examples are the IBM 2702 and 2703 Transmission Controls. Contrast with *communication controller*.

**transmission group (TG).** (1) A connection between adjacent nodes that is identified by a transmission group number. See also *parallel transmission groups*. (2) In a subarea network, a single link or a group of links between adjacent nodes. When a transmission group consists of a group of links, the links are viewed as a single logical link, and the transmission group is called a *multilink transmission group (MLTG)*. A *mixed-media multilink transmission group (MMMLTG)* is one that contains links of different medium types (for example, Token-Ring, switched SDLC, nonswitched SDLC, and frame-relay links). (3) In an APPN network, a single link between adjacent nodes.

**transmission header (TH).** Control information, optionally followed by a basic information unit (BIU) or a BIU segment, that is created and used by path control to route message units and to control their flow within the network. See also *path information unit*.

**transmission line.** Synonym for *telecommunication line*.

**transmission priority.** A rank assigned to a message unit that determines its precedence for being selected by the path control component in each node along a route for forwarding to the next node in the route.

**transmission subsystem (TSS).** A line adapter that attaches to the IBM 3745 Communication Controller.

**twin-tailed.** In NCP, pertaining to the attachment of a communication controller to two host processors. See also *fanout*, *multitailed*, and *tailing*.

**type 2.1 node.** A node that can be an APPN network node, an APPN end node, or a LEN node. It can also attach as a peripheral node to a subarea boundary node in the same way as a type 2.0 node.

**type 5 node.** A node that can be any one of the following:

- APPN end node
- APPN network node
- LEN node
- Interchange node
- Migration data host (a node that acts as both an APPN end node and a subarea node)
- Subarea node (with an SSCP)

Together with its subordinate type 4 nodes, it can also form a composite LEN node or a composite network node.

**T1.** In the United States, a 1.544-Mbps public access line. It is available in twenty-four 64-Kbps channels. The European version (E1) transmits 2.048 Mbps. The Japanese version (J1) transmits 1.544 Mbps.

## U

**UNBIND.** In SNA, a request to deactivate a session between two logical units (LUs). See also *session deactivation request*. Contrast with *BIND*.

**uninterpreted name.** In SNA, a character string that a system services control point (SSCP) can convert into the network name of a logical unit (LU). Typically, an uninterpreted name is used in a logon or Initiate request from a secondary logical unit (SLU) to identify the primary logical unit (PLU) with which the session is requested.

**unsolicited message.** A message, from VTAM to a program operator, that is unrelated to any command entered by the program operator. Contrast with *solicited message*.

**User Datagram Protocol (UDP).** In the Internet suite of protocols, a protocol that provides unreliable, connectionless datagram service. It enables an application program on one machine or process to send a datagram to an application program on another machine or process. UDP uses the Internet Protocol (IP) to deliver datagrams.

## V

**V.25.** In data communications, a specification of the CCITT that defines the automatic answering equipment and parallel automatic calling equipment on the General Switched Telephone Network, including procedures for disabling of echo controlled devices for both manually and automatically established calls.

**V.25 bis.** A procedure defined by CCITT that allows call establishment and data transfer to take place over the same link. The support eliminates the need for two physical lines or ports when automatic call units (ACUs) are employed in a switched connection.

**version.** A separately licensed program that usually has significant new code or new function.

**virtual circuit.** (1) In packet switching, the facilities provided by a network that give the appearance to the user of an actual connection. (T) See also *data circuit*. Contrast with *physical circuit*. (2) A logical connection established between two DTEs.

**virtual machine (VM).** In VM, a functional equivalent of a computing system. On the 370 Feature of VM, a virtual machine operates in System/370 mode. On the ESA Feature of VM, a virtual machine operates in System/370, 370-XA, ESA/370, or ESA/390 mode. Each virtual machine is controlled by an operating system. VM controls the concurrent execution of multiple virtual machines on an actual processor complex.

**Virtual Machine/Enterprise Systems Architecture (VM/ESA).** An IBM licensed program that manages the resources of a single computer so that multiple computing systems appear to exist. Each virtual machine is the functional equivalent of a *real* machine.

**virtual route (VR).** In SNA, either a) a logical connection between two subarea nodes that is physically realized as a particular explicit route or b) a logical connection that is contained wholly within a subarea node for intranode sessions. A virtual route between distinct subarea nodes imposes a transmission priority on the underlying explicit route, provides flow control through virtual route pacing, and provides data integrity through sequence numbering of path information units (PIUs). See also *explicit route (ER)*, *path*, and *route extension (REX)*.

**virtual route (VR) pacing.** In SNA, a flow control technique used by the virtual route control component of path control at each end of a virtual route to control the rate at which path information units (PIUs) flow over the virtual route. VR pacing can be adjusted according to traffic congestion in any of the nodes along the route. See also *pacing* and *session-level pacing*.

**Virtual Storage Extended (VSE).** An IBM licensed program. It is a software operating system controlling the execution of programs.

**Virtual Telecommunications Access Method (VTAM).** An IBM licensed program that controls communication and the flow of data in an SNA network. It provides single-domain, multiple-domain, and interconnected network capability.

**VM/370 control program (CP).** The component of VM/370 that manages the resources of a single computer with the result that multiple computing systems appear to exist. Each virtual machine is the functional equivalent of an IBM System/370 computing system.

**VSE.** Virtual Storage Extended. The basic operating system support needed for a VSE-controlled installation.

**VSE/ESA.** Virtual Storage Extended/Enterprise Systems Architecture.

**VTAM.** Virtual Telecommunications Access Method. Synonymous with *ACF/VTAM*.

## W

**wide area network (WAN).** (1) A network that provides communication services to a geographic area larger than that served by a local area network or a metropolitan area network, and that may use or provide public communication facilities. (T) (2) A data communications network designed to serve an area of hun-

## Glossary

dreds or thousands of miles; for example, public and private packet-switching networks, and national telephone networks. Contrast with *local area network (LAN)*.

**window size.** The specified number of frames of information that can be sent before receiving an acknowledgment response.

**workstation.** (1) A functional unit at which a user works. A workstation often has some processing capability. (T) (2) One or more programmable or nonprogrammable devices that allow a user to do work. (3) A terminal or microcomputer, usually one that is connected to a mainframe or to a network, at which a user can perform applications.

## X

**X-on.** Transmitter on.

**X.21.** An International Telegraph and Telephone Consultative Committee (CCITT) recommendation for a general-purpose interface between data terminal equipment and data circuit-terminating equipment for synchronous operations on a public data network.

**X.25.** An International Telegraph and Telephone Consultative Committee (CCITT) recommendation for the interface between data terminal equipment and packet-switched data networks. See also *packet switching*.

**X.25 NCP Packet Switching Interface (NPSI).** An IBM licensed program that allows SNA users to communicate over packet switching data networks that have interfaces complying with CCITT Recommendation X.25. It allows SNA programs to communicate with SNA or non-SNA equipment over such networks.

**X.25 outboard data link control (ODLC).** X.25 protocols processed by the IBM 3746 Model 900 connectivity subsystem (CSS) *outboard data link control* (ODLC) in conjunction with the IBM Network Control Program (NCP) licensed program.

**XMIT.** Transmit.

## 3

**37CS.** Synonym for *3746 Model 900 connectivity subsystem (CSS)*.

---

# Bibliography

---

## NCP, SSP, and EP Library

---

The following paragraphs briefly describe the library for NCP, SSP, and EP. Other publications related to NTuneMON, VTAM, NPSI, NetView, NTO, and NRF are listed without the accompanying descriptions.

*NCP and EP Reference* (LY43-0029)

This book describes various aspects of the internal processing of NCP and EP (PEP or EP Standalone). It provides information for customization and diagnosis.

*NCP and EP Reference Summary and Data Areas* (LY43-0030)

This two-volume book provides quick access to often-used diagnostic and debugging information about NCP and EP (PEP or EP Standalone).

*NCP and SSP Customization Guide* (LY43-0031)

This book helps users who are familiar with the internal logic of NCP and SSP to modify these products. It describes how to change NCP and SSP to support stations that IBM-supplied programs do not support.

*NCP and SSP Customization Reference* (LY43-0032)

This book supplements the *NCP and SSP Customization Guide*. It describes the resources and macroinstructions provided by IBM for customizing NCP and SSP.

*NCP, SSP, and EP Diagnosis Guide* (LY43-0033)

This book helps users isolate and define problems in NCP and EP (PEP or EP Standalone) using SSP. The primary purpose of the book is to help the user interact with the IBM Support Center to resolve a problem. In addition, it explains some of the diagnostic aids and service aids available with SSP.

*NCP, SSP, and EP Trace Analysis Handbook* (LY43-0037)

This book describes how to use the trace analysis program and how to read trace analysis program output.

*NCP, SSP, and EP Generation and Loading Guide* (SC31-6221)

This book provides detailed explanations of how to generate and load NCP and EP (PEP or EP Standalone)

using SSP. It contains information for generating and loading under MVS, VM, and VSE.

*NCP, SSP, and EP Messages and Codes* (SC31-6222)

This book is a reference book of abend codes issued by NCP and EP (PEP or EP Standalone), and messages issued by the System Support Programs associated with NCP. This information is also available through the online message facility, an IBM OS/2 application available on diskette.

*NCP, SSP, and EP Resource Definition Guide* (SC31-6223)

This book helps users understand how to define NCP and EP (PEP or EP Standalone), using SSP. It describes functions and resources and lists the definition statements and keywords that define those functions and resources.

*NCP, SSP, and EP Resource Definition Reference* (SC31-6224)

This book helps users code definition statements and keywords to define NCP and EP (PEP or EP Standalone), using SSP. It also provides a quick reference of definition statement coding order and keyword syntax.

*NCP V7R8, SSP V4R8, and EP R14 Library Directory* (SC30-4025)

This book helps users locate information on a variety of NCP, SSP, and EP tasks. It also provides a high-level understanding of NCP, SSP, and EP and summarizes the changes to these products and to the library for NCP V7R8, SSP V4R8, and EP R14.

*NCP V7R8 Migration Guide* (SC30-4024)

This book helps users migrate an NCP generation definition from an earlier release to NCP V7R8. It also describes how to add new functions for NCP V7R8.

*NCP Version 7 and X.25 NPSI Version 3 Planning and Installation* (SC30-3470)

This book helps users plan and install support for X.25 lines in the 3745 or 3746 Model 900.

*NCP Version 7 and X.25 NPSI Version 3 Diagnosis, Customization, and Tuning* (LY30-5610)

This book helps users diagnose, customize, and tune X.25 lines in the 3745 or 3746 Model 900.

---

### Other Networking Products' Libraries

The following publications provide cross-product information for NTuneMON, SNA Services (VTAM), NPSI, NetView, and NPM. For detailed information about these products, refer to the library for each.

### Networking Library

*Planning for NetView, NCP, and VTAM* (SC31-8063)

*Planning for Integrated Networks* (SC31-8062)

*ACF/NCP, ACF/SSP, EP, NTuneMON, and NPSI Softcopy Collection Kit* (CD-ROM, LK2T-0414)

### NTuneMON Library

*NTuneMON User's Guide* (SC31-6266)

*NTuneNCP Feature Reference* (LY43-0039)

**Related Publication:** *NCP Tuning with NTune*, GG24-2520

### SNA Services Library (formerly VTAM Library)

*OS/390 SecureWay Communications Server: SNA Planning and Migration Guide* (SC31-8622)

*OS/390 SecureWay Communications Server: SNA Network Implementation* (SC31-8563)

*OS/390 SecureWay Communications Server: SNA Resource Definition Reference* (SC31-8565)

*OS/390 SecureWay Communications Server: SNA Operation* (SC31-8567)

*OS/390 SecureWay Communications Server: Quick Reference* (SX75-0121)

*OS/390 SecureWay Communications Server: SNA Diagnosis Vol 1* (LY43-0079)

*OS/390 SecureWay Communications Server: SNA Diagnosis Vol 2* (LY43-0080)

*OS/390 SecureWay Communications Server: SNA Messages* (SC31-8569)

*OS/390 SecureWay Communications Server: IP and SNA Codes* (SC31-8571)

*OS/390 SecureWay Communications Server: Data Areas Vol 1* (LY43-0111)

*OS/390 SecureWay Communications Server: Data Areas Vol 2* (LY43-0112)

*OS/390 SecureWay Communications Server: SNA Customization* (LY43-0110)

*OS/390 SecureWay Communications Server: Anynet Sockets over SNA* (SC31-8577)

### NPSI Library

*X.25 NPSI Version 3 General Information* (GC30-3469)

*NCP Version 7 and X.25 NPSI Version 3 Planning and Installation* (SC30-3470)

*X.25 NPSI Version 3 Host Programming* (SC30-3502)

*NCP Version 7 and X.25 NPSI Version 3 Diagnosis, Customization, and Tuning* (LY30-5610)

*X.25 NPSI Version 3 Release 9 Data Areas* (LY30-5627)

### NetView Library

*TME 10 NetView for OS/390 NGMF User's Guide* (SC31-8234)

*TME 10 NetView for OS/390 User's Guide* (SC31-8241)

*TME 10 NetView for OS/390 Administration and Security Reference* (SC31-8222)

*TME 10 NetView for OS/390 Application Programmer's Guide* (SC31-8223)

*TME 10 NetView for OS/390 Automation Guide* (SC31-8225)

*TME 10 NetView for OS/390 Bridge Implementation* (SC31-8238)

*TME 10 NetView for OS/390 Command Reference* (SC31-8227)

*TME 10 NetView for OS/390 Customization Guide* (SC31-8228)

*TME 10 NetView for OS/390 Customization: Using Assembler* (SC31-8229)

*TME 10 NetView for OS/390 Customization: Using PL/I and C* (SC31-8230)



*TME 10 NetView for OS/390 Customization: Using REXX and the NetView Command List Language* (SC31-8231)

*TME 10 NetView for OS/390 Planning Guide* (GC31-8226)

*TME 10 NetView for OS/390 Installation and Administration Guide* (SC31-8236)

*TME 10 NetView for OS/390 Messages* (SC31-8237)

*TME 10 NetView for OS/390 Diagnosis Guide* (LY43-0108)

*TME 10 NetView for OS/390 Resource Object Data Manager and GMFHS Programmer's Guide* (SC31-8233)

*TME 10 NetView for OS/390 Tuning Guide* (SC31-8240)

*TME 10 NetView for OS/390 User's Guide* (SC31-8241)

*TME 10 NetView for OS/390 NGMF User's Guide* (SC31-8234)

*TME 10 NetView for OS/390 SNA Topology Manager and APPN Accounting Manager Implementation Guide* (SC31-8239)

*TME 10 NetView for OS/390 Data Model Reference* (SC31-8232)

*TME 10 NetView for OS/390 APPN Topology and Accounting Agent Guide* (SC31-8224)

## NPM Library

*NPM Concepts and Planning* (GH19-6961-03)

*NPM Installation and Customization* (SH19-6964-03)

*NPM Desk/2 User's Guide* (SH19-6963-02)

*NPM User's Guide* (SH19-6962-03)

*NPM Messages and Codes* (SH19-6966-03)

*NPM Graphic Subsystem* (SH19-6967-00)

*NPM Reference* (SH19-6965-03)

*NPM Diagnosis* (LY19-6381-03)

## NTO Library

*Network Terminal Option: Planning, Migration, and Resource Definition Guide* (SC30-3347)

*Network Terminal Option: Diagnosis* (LY30-3194)

## NRF Library

*NRF Planning* (SC27-0593)

*NRF Migration, Resource Definition and Customization* (SC31-6203)

*NRF Resource Definition and Customization* (SC30-3407)

*NRF Diagnosis* (LY30-5597)

---

## Related Publications

The following publications, though not directly related to this book, may be helpful in understanding your network.

*Internet Standard Subnetting Procedure (TCP/IP RFC 950)*

*Network Design and Analysis General Information* (GC30-3495)

*Remote Loading/Activation Guide* (SA33-0161)

*3745 and 3746 Service Processor Installation and Maintenance* (SY33-2115)

*TPF Concepts and Structures Manual* (GH20-7488)

## IBM 3745 Communication Controller Publications

The following list shows selected publications for the IBM 3745 Communication Controller.

*IBM 3745 Communication Controller Introduction* (GA33-0138 for the 3745-130, 3745-150, and 3745-170)

*IBM 3745 Communication Controller Introduction* (GA33-0092 for the 3745-210, 3745-310, 3745-410, and 3745-610)

*IBM 3745 Communication Controller All Models and 3746 Model 900: Connection and Integration Guide* (SA33-0129)

*3745 Communications Controller Models 130, 150, 160, and 170: Connection and Integration Guide* (SA33-0141)

*IBM 3745 Communication Controller (All Models): Principles of Operation* (SA33-0102)

*IBM 3745 Advanced Operations Guide* (SA33-0097)

## Bibliography

*3745 Communication Controller Model A, 3746 Nways Multiprotocol Controller Models 900 and 950: Planning Guide* (GA33-0457)

*IBM 3745 Problem Determination Guide* (SA33-0096)

### IBM 3746 Model 900 and Model 950 Publications

*IBM 3745 Communication Controller Model A, IBM 3746 Expansion Unit Model 900, IBM 3746 Nways Multinet-work Controller Model 950 Overview* (GA33-0180)

*IBM 3746 Nways Multinet-work Controller Model 950 User's Guide* (SA33-0356)

### MVS/ESA Publications

*MVS/ESA Device Validation Support* (GC28-1617)

*MVS/ESA Hardware Configuration Definition: User's Guide* (GC33-6457)

### SNA Publications

The following publications contain information on SNA.

*Systems Network Architecture Technical Overview* (GC30-3073)

*Systems Network Architecture Management Services Reference* (SC30-3346)

*Systems Network Architecture Formats* (GA27-3136)

### TCAM Publications

*TCAM Version 2 Base Installation Guide* (SC30-3132)

*TCAM Version 2 Networking Installation Guide* (SC30-3153)

### TCP/IP Publications

The following publications contain information on Transmission Control Protocol/Internet Protocol (TCP/IP).

**General:** The following list shows selected publications with general information on TCP/IP.

*Internetworking with TCP/IP Volume I: Principles, Protocols, and Architecture*, Douglas E. Comer, Prentice Hall, Englewood Cliffs, New Jersey, 1991 (SC31-6144)

*Internetworking with TCP/IP Volume II: Implementation and Internals*, Douglas E. Comer, Prentice Hall, Englewood Cliffs, New Jersey, 1991 (SC31-6145)

*TCP/IP Introduction* (GC31-6080)

*IBM TCP/IP Tutorial and Technical Overview* (GG24-3376)

**OS/390 Publications:** The following list shows selected publications on IP Services for the OS/390 SecureWay Communications Server.

*OS/390 SecureWay Communications Server: IP Planning and Migration Guide* (SC31-8512)

*OS/390 SecureWay Communications Server: IP User's Guide* (GC31-8514)

**MVS Publications:** The following list shows selected publications on TCP/IP for MVS.

*IBM TCP/IP for MVS: Planning and Migration Guide* (SC31-7189)

*IBM TCP/IP for MVS: User's Guide* (SC31-7136)

**VM Publications:** The following list shows selected publications on TCP/IP for VM.

*IBM TCP/IP Version 2 Release 4 for VM: Planning and Customization* (SC31-6082)

*IBM TCP/IP Version 2 Release 4 for VM: User's Guide* (SC31-6081)

**IBM OS/2 Publications:** The following list shows selected publications on TCP/IP for IBM OS/2.

*IBM TCP/IP Version 2.0 for OS/2: Installation and Administration* (SC31-6075)

*IBM TCP/IP Version 2.0 for OS/2: User's Guide* (SC31-6076)

**DOS Publications:** The following list shows selected publications on TCP/IP for DOS.

*IBM TCP/IP Version 2.1.1 for DOS: Installation and Administration* (SC31-7047)

*IBM TCP/IP Version 2.1.1 for DOS: User's Guide* (SC31-7045)

# Index

## Numerics

2210 Multiprotocol Router 16-18  
 2701 Data Adapter Unit 21-1, 21-17, 21-18  
 2702 Transmission Control Unit 21-1  
 2703 Transmission Control Unit 21-1  
 2845 display controller 21-19  
 2848 display controller 21-19  
 3174 group poll 5-42  
 3174 group polling description 5-42  
 3174, group polling description 5-42  
 370 I/O channels 15-18  
 3745 Communication Controller  
   channel adapter 4-2, 4-5, 15-19  
   configuration 3-2  
   Controller Load and Dump Program (CLDP) 12-29  
   defining to VTAM 4-29  
   description of models xxix, 3-1, 3-2  
   ESCON adapter 4-9  
   exceeding storage capacity 8-1  
   fallback and switchback 3-2  
   frame handler connections 16-60  
   power-off feature 12-28  
   storage size 3-2  
   type 3-2  
 3745 publications X-37  
 3746 Model 900 connectivity subsystem  
   3745 ESCON Generation Assistant 4-12, 4-22  
   controlling adapter overrun errors 24-14  
   fallback and switchback 3-8  
   frame handler logical connections not supported 6-35  
   frame-relay resources 16-1, 16-12, 16-21, 16-72, 16-85  
   ISDN resources 7-1  
   SDLC lines  
     Converting IBM 3745 SDLC lines 5-21  
     LPDA tests 23-5, 23-6  
     SDLC lines 3-6, 5-1  
     X.21 lines 5-6, 12-29  
   shared ESCON resources 3-7  
   shared frame-relay resources 3-7  
   shared Token-Ring resources 3-7  
 3746 publications X-38  
 37CS, SDLC lines  
   See 3746 Model 900 connectivity subsystem  
 37CS, term xxix  
 4941 modem 23-16  
 786x modems 23-5

## A

ACCESS keyword 9-3  
 access method characteristics  
   defining channels 4-1  
   dynamic control facilities 4-29  
   NCP buffers  
     limit 24-3  
     selecting size 24-1  
 acknowledgment timer, Token-Ring (T2) 6-42, 6-45  
 ACR keyword 17-5  
 activating a remote controller  
   over frame-relay lines 16-73  
   over ISDN lines 7-32  
   over SDLC and X.21 lines 12-29  
   over Token-Ring lines 6-48  
 ACTIVTO keyword 7-15, 12-6, 12-14, 12-31  
 ACTPU keyword 14-4  
 adapter  
   overrun errors 24-14  
   Token-Ring  
     type 1 6-7, 6-15, 6-35, 15-31, 16-64  
     type 2 6-7, 6-15, 6-35, 15-31, 16-64  
     type 3 6-1, 6-7, 6-15, 6-35, 15-31, 15-40, 16-64  
 ADAPTER keyword 6-7, 15-31, 15-40, 16-64  
 ADD definition statement  
   keywords 10-1  
   usage and position 1-25  
 ADDIFG keyword 24-14  
 adding and deleting devices dynamically 10-2  
 ADDR keyword 4-16, 5-33, 5-41, 6-12, 12-7, 12-33, 15-23, 15-33, 15-41, 16-59, 16-65  
 address  
   control blocks 14-8  
   pools 14-9  
   specifications 5-37  
   Token Ring 6-10, 15-32  
   trace 1-5, 23-2  
 ADDRESS keyword 2-16, 4-21, 5-2, 6-8, 7-6, 7-11, 7-15, 13-5, 15-25, 15-32, 15-41, 16-10, 16-64  
   EP 21-11  
 Address Resolution Protocol (ARP) 15-28, 15-35  
 ADDSESS keyword 2-10, 8-8  
 ADPLIMIT keyword 8-3, 8-5  
 alerts  
   excessive buffer usage 23-19  
 allocating unassigned logical line pools 6-25  
 ANS (automatic network shutdown) 12-6, 16-31, 25-1  
 ANS keyword 4-6, 4-13, 4-16, 7-7, 7-12, 15-20, 15-23, 15-26, 15-33, 15-41, 16-49, 16-65, 16-68, 25-3  
 ANSTONE keyword 23-15

## Index

- APPN (Advanced Peer-to-Peer Networking)
    - composite type 2.1 node 8-13
    - defining logical units 8-11
    - generating 8-14
    - overview 8-13
  - APPN HPR (Advanced Peer-to-Peer Networking High Performance Routing)
    - composite type 2.1 node 8-13
    - generating 8-14
    - overview 8-14
    - snap trace 23-2
  - APPN HPR (High Performance Routing)
    - See APPN HPR (Advanced Peer-to-Peer Networking High Performance Routing)
  - ARP (Address Resolution Protocol) 15-28, 15-35
  - ARPTAB keyword 15-26, 15-31, 15-33, 15-40, 15-46, 16-64
    - where to code 10-6
  - ASLENT keyword of VTAM 5-33
  - ASLTAB keyword of VTAM 5-33
  - ATTN keyword 5-28
  - AUTO keyword 5-6, 5-8, 23-16
    - EP 21-15
  - auto-adaptive connection balancing 6-10, 16-15
  - AUTOCOPY keyword 2-12, 7-11, 7-15, 7-19
  - AUTODL keyword 5-6
  - AUTOGEN keyword 6-22, 7-15, 7-19, 16-48
  - AUTOLINE keyword 2-16
  - automatic calling unit 21-6, 21-15
  - automatic line generation 2-12, 2-16
  - automatic network shutdown (ANS) 12-6, 16-31, 25-1
  - AUTUACB keyword 13-3
  - AUXADDR keyword 2-10, 8-8
  - AVGPB keyword 5-38
- ## B
- B-channel
    - See integrated services digital network (ISDN), B-channels
  - backup and recovery procedures
    - automatic network shutdown 25-1
    - error recovery and recording 25-4
    - SDLC devices 25-6
  - backup IP channel interfaces 15-8
  - BACKUP keyword 2-11, 25-6
  - backup of frame-relay over ISDN 16-22
  - backup sessions 25-6
  - backup TICs 6-15
  - backward explicit congestion notification (BECN) indicator 16-60
  - BALANCE keyword 6-8, 16-14
  - BAN (boundary access node) 16-10, 16-45
  - bandwidth 16-60
  - BCCA (buffer-chaining channel adapter) 4-7
  - BEACTO keyword 6-10, 15-32, 15-41, 16-64
  - BECN (backward explicit congestion notification) indicator 16-60
  - BFRDLAY keyword 5-46
  - BFRS keyword 2-11, 12-26, 24-1
    - EP 21-14
  - BHEXEC keyword 9-2, 9-6
  - BHSET definition statement
    - keywords 9-4
    - usage and position 1-25
  - BHSET keyword 9-6
  - bibliography X-35
  - BKSP keyword 9-2
  - block handler definition statements 1-7
  - block handlers 9-1—9-7
    - beginning 9-1
    - control character removal 9-4
    - edit routine 9-2
    - ending 9-2
    - sets 9-6
    - time and date routine 9-2
    - user-written routines 9-3
  - BLOCK keyword 7-16, 16-32, 24-7
  - BNN (boundary network node) 16-45
  - BNNSUP keyword 5-33
  - boundary access node (BAN) 16-10, 16-45
  - boundary channel link
    - channel activity 4-2, 4-13
    - channel discontact 4-3, 4-6, 15-20
    - defining 4-4
    - with a channel adapter 4-5
  - boundary network node (BNN) 16-45
  - BRANCH keyword 23-2
    - EP 21-13
  - branch trace 23-2
    - EP 21-13
  - BRKCON keyword 12-14
  - broadcasts, Internet Protocol 15-5
  - BSB (boundary session control block) 8-4, 8-8, 8-9
  - BSC devices
    - automatic network shutdown 25-3
    - emulation mode 20-1
    - EP 21-14
  - BSC line control 21-12
  - BUFETTE keyword 20-6
    - EP 21-20
  - buffer-chaining channel adapter (type 7) 4-7
  - buffers
    - EP 21-14
    - free buffer pool 24-2
    - size 2-11, 12-26, 24-1
    - specifying number for data transfer 6-31, 12-18, 16-31
    - transferring data 24-2
  - BUFSIZE keyword 20-6
    - EP 21-18

## BUILD definition statement

EPSA 21-3  
 ignored keywords (EP) 21-9  
   JOB CARD 21-9  
   LESIZE 21-9  
   OBJLIB 21-9  
   UNIT 21-9  
   UT1 21-9  
   UT2 21-9  
   UT3 21-9  
 keywords  
   ADDSESS 2-10, 8-8  
   ADPLIMIT 8-3, 8-5, 24-6  
   AUXADDR 2-10, 8-8  
   BACKUP 2-11, 25-6  
   BFRS 2-11, 12-26, 24-1  
   BRANCH 23-2  
   CAIOTRC 23-1  
   CATRACE 23-1  
   CNLSQMAX 15-59  
   CNLSQTIM 15-59  
   CSMHDR 25-3  
   CSMHDRC 25-3  
   CSMSG 25-3  
   CSMSGC 25-3  
   CSSTIER 3-2  
   CUID 5-30  
   C WALL 24-3  
   DIALTO 24-10  
   DR3270 10-5  
   DSABLTO 24-10  
   DYNNSC 2-11  
   DYNNSX 2-11  
   DYNPOOL 2-11  
   ENABLTO 24-10  
   ERLIMIT 11-4  
   GENILU 8-9  
   GENLEVEL 2-5  
   GWAEXIT 14-24  
   GWSESAC 2-11, 14-25  
   HICHAN 20-2  
   HPR 8-16  
   HPRATT 8-17  
   HPRMLC 8-18  
   HPRMPS 8-16  
   HPRQLIM 8-20  
   HPRSNAP 8-19  
   HSBPOOL 2-10, 14-3, 14-11  
   IPPOOL 15-59  
   IPRATE 15-59  
   IPSNAP 15-59  
   ITEXTTO 24-11  
   LENAME 2-6  
   LOCALTO 6-21, 6-45  
   LOCHAN 20-2  
   LTRACE 23-3  
   MAXSESS 8-9

BUILD definition statement (*continued*)

keywords (*continued*)  
   MAXSSCP 4-27  
   MAXSUBA 4-26  
   MEMSIZE 3-2  
   MINILOAD 2-6  
   MLTGORDR 12-17  
   MODEL 3-2  
   MTARTO 24-20  
   MTARTRY 24-20  
   NAMTAB 2-7, 2-11, 8-12, 14-3  
   NCPTRACE 23-2  
   NETID 2-7, 14-3  
   NETLIM 14-11  
   NEWNAME 2-8  
   NPA 14-25, 24-16, 24-19  
   NTRISNAP 23-3  
   NUMHSAS 4-27  
   OLT 23-3  
   PATHEXT 11-13  
   PRTGEN 2-8  
   PUNAME 2-8  
   PWROFF 12-28  
   QSZALERT 23-19  
   REMOTTO 6-21, 6-45  
   RGENLEVEL 2-6  
   SALIMIT 4-26, 14-5  
   SESSACC 2-11, 24-15  
   SESSLIM 14-11  
   SLODOWN 24-3  
   SUBAREA 2-8, 4-26  
   T2TIMER 6-21, 6-42, 6-45  
   TGBXTRA 11-13  
   TGTIMER 23-19  
   TIMER 13-2  
   TRACE 23-2  
   TRANSFR 12-26  
   TRCPIU 24-7  
   TWXID 18-3  
   TYPGEN 2-8  
   TYP SYS 2-9  
   UCHAN 13-5  
   USGTIER 3-2  
   VERSION 2-9  
   VRPOOL 4-28, 11-14  
   VRTIMERn 23-18  
   XBREAK 24-14

usage and position 1-9

byte multiplexer channel 21-1

**C**

CA keyword 4-2, 4-13, 4-21  
 CA line control 21-12  
 CAEXIT keyword 13-5

## Index

- CAIOTRC keyword 23-1
- CALINE keyword 23-6
- CALL keyword 5-6, 5-9, 6-23, 7-11
- CALLIN, definition of term
- CAPACITY value 5-3, 5-7, 8-21
- CASDL keyword 4-3, 4-5, 4-16, 15-20, 15-23
- casual connection 8-1, 12-29
- CATRACE keyword 23-1
- CBSP (controller bus and service processor) Token-Ring connection 6-10, 6-34
- CCLID keyword 5-6
- CCU (communication control unit)
  - single 3-2
  - twin 3-2
- CD-ROM documentation xxxiv
- CDRSCs (cross-domain resources) 8-2, 8-6, 8-9
- CHANLA keyword 23-6, 23-11
- CHANLNK keyword 13-5
- channel adapter IOH trace 23-1
- channel adapter trace 23-1
- channel adapter, type 7 (buffer-chaining) 4-7
- channel adapters, defining (EP) 21-11
- channel attachments for IP, defining 15-18
- channel connections from the host 10-7
- channel interface
  - as internet transmission medium 15-22
- channel links
  - defining 4-1
  - ESCON 4-9
  - peripheral links
    - attention signals 4-16, 15-23
    - blocking inbound data 4-16, 15-23
    - coding example 4-8
    - defining 4-4, 4-7
    - initiating discontact 4-6, 15-20
  - subarea links
    - attention signals 4-3, 4-6, 15-20
    - blocking inbound data 4-3, 4-5, 15-20
    - coding example 4-8
    - defining 4-2, 4-7
    - initiating discontact 4-3
    - PU type 4-3, 4-6, 4-17, 15-21, 15-23
- channel-attached devices 4-1
- channel, defining (EP) 21-11
- character transmission
  - TWX terminals 18-1
  - WTTY terminals 19-1
- CHAREC keyword 18-1
  - EP 21-20
- CHECK keyword 20-4
  - EP 21-19
- checksum support 24-9
- CHNLZ keyword 5-24, 23-6, 23-11
- CHNPRI keyword 20-2
  - EP 21-16
- CIR (committed information rate)
  - definition of term 16-6
- CIR keyword 16-10, 16-13
  - ISDN 7-6
  - not valid for 3745 frame relay 16-72
- class D address 15-5
- CLDP (Controller Load and Dump Program), IBM 3745 12-29
- CLINES keyword 23-7
- CLLM (Consolidated Link Layer Management)
  - definition of term 16-7
- CLLM keyword 16-11
- CLOCKNG keyword 5-2, 16-11, 17-5
  - EP 21-14
- cluster controller 21-14
- CLUSTER definition statement
  - keywords
    - BHEXEC 9-6
    - BHSET 9-6
    - CUTYPE 5-27
    - EXEC 9-6
    - FEATURE 5-27
    - GPOLL 5-41
    - INHIBIT 24-12
    - ITBMODE 5-44
    - LGRAPHS 5-28
    - LMODADR 23-16
    - NEXT 2-13
    - NPACOLL 24-17
    - PT3EXEC 9-6
    - SEGMENT 23-16
  - usage and position 1-18
- clustered stations 21-14
- CNLSQMAX keyword 15-59
- CNLSQTIM keyword 15-59
- CODE keyword 5-43, 17-3, 17-4, 17-5, 17-7
  - EP 21-19
- coding examples
  - autocopy function 2-14
  - autoline function 2-17
  - block handlers
    - block handler set 9-5
    - using a block handler set 9-7
- BSC and start-stop devices 5-32
- casual connection
  - primary NCP 12-34
  - secondary NCP 12-35
- channel links
  - ESCON channel 4-21
  - ESCON logical line 4-18
  - ESCON physical line 4-14
  - peripheral links 4-7
  - subarea links 4-4
  - System/370 I/O channel 4-19
  - type 7 adapter 4-8
- communication controller 3-2

- coding examples (*continued*)
  - concurrent sessions 4-28
  - configurable point-to-point subarea links 12-9
  - converting to 3746 Model 900 SDLC lines 5-21
  - converting to serial I/O channels 4-18
  - cross-network resources
    - session values 14-13
    - sessions in gateway NCP 14-14
  - data characteristics 5-45
  - delay between successive transmissions 5-46
  - dynamic allocation of addresses 14-13
  - dynamic path update 11-14
  - dynamic reconfiguration
    - adding and deleting logical units 10-5
    - moving a logical unit 10-2
    - moving a physical unit 10-2
    - reconfiguring link devices 10-3
  - emulation mode
    - subchannels 20-8
    - telecommunication links 20-3
  - end of transmission 5-45
  - ESCON links
    - ESCON link 4-21
    - ESCON logical line 4-18
    - ESCON physical line 4-14
  - Ethernet-type LAN
    - Ethernet-type LAN attachment 15-30
    - two NCPs and three Ethernet-type LAN attachments 15-63
  - explicit routes
    - alternate routes 11-8
    - between subareas 11-5, 11-7, 11-12
  - fallback and switchback for 3746 Model 900 resources 3-9
  - frame relay
    - converting SDLC subarea links to frame relay 16-38
    - ISDN backup 16-27
    - logical connection 16-42
    - network with 3746 Model 900 FHSP and TESP connections 16-87
    - network with FHSP and TESP connections 16-82, 16-84
    - network with FHSP connections 16-79, 16-80
    - physical line 16-21, 16-22
    - routing paths 16-62
    - subarea link connections 16-78
  - IBM 3174 group poll 5-43
  - Internet Protocol
    - direct routes 15-57
    - Ethernet-type LAN attachment 15-30
    - indirect routes 15-57
    - NCST and LU-LU sessions (primary and backup) 15-14
    - NCST routes 15-57
    - NTRI attachment 15-51
    - performance 15-60
  - coding examples (*continued*)
    - Internet Protocol (*continued*)
      - subnetworks 15-57
    - ISDN
      - B-channels 7-13
      - peripheral lines 7-21
      - physical lines 7-10
      - subarea lines 7-18
    - logical unit definition in the gateway NCP 14-14
    - LU-LU sessions (primary and backup) 15-14
    - mixed-media MLTG (MMLTG) 12-21
    - MLTG 12-20
    - modems
      - channelized 5-24
      - full-data-multiplex 23-15
      - local modem addresses 23-17
      - LPDA-1 channelized modem link 23-9
      - LPDA-1 nontailed telecommunication link 23-10
      - LPDA-2 nontailed nonchannelized link 23-12
      - LPDA-2 tailed nonchannelized link 23-13
      - modem definition 5-23
    - MTALCST (two definition statements) 17-4
    - MTALCST for a 2741 using BCD code 17-4
    - MTATABL for a 2741 using BCD code 17-4
    - new generation definition 2-2
    - NEWDEFN file created by the autocopy function 2-15
    - NEWDEFN file created by the autoline function 2-18
    - non-native network 14-5
    - nonswitched telecommunication links 5-4
    - packed NEWDEFN file 2-3
    - parallel and multiple sessions 8-10
    - parallel transmission groups 12-28
    - PATH statements for dynamically added networks 14-21
    - PATH statements for dynamically added networks (optimized) 14-23
    - peripheral channel links 4-7
    - polling and addressing 5-42
    - reusable NEWDEFN file 2-3
    - reusable NEWDEFN file created by NDF 2-4
    - SDLC devices 5-34
    - SDLC devices on switched telecommunication links 5-36
    - SDLC lines, 3746 Model 900 5-21
    - SMMF
      - ESCON link 5-19
      - nonswitched peripheral subarea link 5-16
      - nonswitched SDLC subarea link 5-13
      - subarea channel link 5-17
      - switched SDLC subarea link 5-15
    - stand-alone MTA line group 1-16
    - stand-alone SDLC line group 1-15
    - subarea links
      - addressability 4-27
      - channel links 4-4

## Index

- coding examples (*continued*)
    - subarea links (*continued*)
      - multipoint subarea link (primary NCP) 12-12
      - multipoint subarea link (secondary NCP) 12-13
      - point-to-point subarea link (primary NCP) 12-11
      - point-to-point subarea link (secondary NCP) 12-11
      - switched subarea link 12-15
        - using MODULO=128 12-9
    - switched network backup 5-25
    - switched telecommunication links 5-7
    - system generation definitions
      - A03620 A-7
      - A04620 A-39
      - A31620 A-82
      - B31620 A-128
      - B75620 A-155
      - C04620 A-191
    - System/370 channel link 4-19
    - Token Ring
      - converting a type 2 TIC to a type 3 TIC 6-36
      - duplicate TIC lines 6-18, 6-20
      - error recover and retry for logical connections 6-47
      - generation definition 6-49
      - logical connections 6-24
      - logical subarea connections 6-33
      - NTRI with peripheral lines 6-27
      - performance 6-44
      - subarea physical connections 6-29
      - timers for logical connections 6-47
      - type 2 and type 3 physical connections 6-14
      - type 2 TIC 6-36
      - type 3 TIC 6-38
    - TWX terminal features 18-2
    - type 2.1 physical units 8-6
    - type 7 channel adapter 4-8
    - V.25 bis 5-10
  - coding internet route definitions for best performance 15-59
  - collection, data
    - basic 24-16
    - by transmission priority 24-18
  - COMMAND keyword 9-3
  - committed information rate (CIR)
    - definition of term 16-6
  - communication control unit (CCU)
    - single 3-2
    - twin 3-2
  - communication controller
    - defining characteristics to EP 21-11
    - operational characteristics (EP) 21-11
    - physical characteristics (EP) 21-11
  - COMP definition statement
    - keywords (*continued*)
      - BHEXEC 9-6
      - BHSET 9-6
      - CONV 5-28
      - ENDTRNS 5-45
      - INHIBIT 24-13
      - ITBMODE 5-44
      - LGRAPHS 5-28
      - NEXT 2-13
      - POLL 5-41
      - PT3EXEC 9-6
      - SRT 25-5
    - usage and position 1-19
  - COMPACB keyword 13-2
  - COMPARE keyword 18-4
  - composite ANR mode 8-13
  - composite APPN network node 8-13
  - composite type 2.1 node 8-13
  - COMPOWN keyword 3-6, 13-2
  - COMPSWP keyword 6-16, 13-2
  - COMPTAD keyword 3-6, 13-2
  - COMRATE keyword 6-12, 15-33, 15-46, 16-32, 16-49, 16-59, 16-65, 16-66, 16-68
    - relationship with DATBLK, MAXDATA 16-76
    - relationship with FRRATES 16-76
  - CONFIG keyword 12-7
  - configuration definition statements 1-5
  - configuring SDLC subarea links 12-2
  - congestion indicators, frame relay (BECN and FECN) 16-60
  - connection balancing, DLCI 16-14
  - connection balancing, duplicate TICs 6-16
    - factor 6-8
    - granularity 6-9
  - connectionless transport sessions for Internet Protocol 15-1
  - connections, Ethernet-type LAN 1-21, 15-25
  - connectivity subsystem (CSS)
    - 3745 ESCON Generation Assistant 4-12, 4-22
    - controlling adapter overrun errors 24-14
    - fallback and switchback 3-8
    - frame-relay resources 16-1, 16-12, 16-21, 16-72, 16-85
    - ISDN resources 7-1
  - SDLC lines
    - Converting IBM 3745 SDLC lines 5-21
    - LPDA tests 23-5, 23-6
    - SDLC lines 3-6, 5-1
    - X.21 lines 5-6, 12-29
  - shared ESCON resources 3-7
  - shared frame-relay resources 3-7
  - shared Token-Ring resources 3-7
- Consolidated Link Layer Management (CLLM)
  - definition of term 16-7



control blocks  
     dynamically created 2-10  
     monitoring usage of 24-17

control character removal 9-4

control units for emulation mode 20-5, 21-14

controller bus and service processor (CBSP) Token-Ring connection 6-10, 6-34

Controller Load and Dump Program (CLDP), IBM 3745 12-29

CONV keyword 5-28

converting I/O channel links to ESCON links  
     conversion steps 4-18  
     definition 4-19  
     multiple PUs on a logical line 4-19

converting to 3746 Model 900 SDLC resources  
     conversion steps 5-21  
     definition 5-21

converting to 3746 Model 900 Token-Ring resources  
     conversion steps 6-36  
     definition 6-35

COPIES keyword 14-4, 14-18

CORNUM keyword 5-24, 23-7, 23-11

CRDLAY keyword 5-28

CRETRY keyword 25-4

CRITSIT keyword 25-3

cross-domain resources (CDRSCs) 8-2, 8-6, 8-9

cross-network  
     paths 14-15  
     sessions 14-8  
     to VTAM 14-23

CRRATE keyword 5-27, 17-5

CSMHDR keyword 25-3

CSMHDR keyword 25-3

CSMSG keyword 25-3

CSMSGC keyword 25-3

CSPMODE keyword  
     EP 21-15

CSS (connectivity subsystem)  
     3745 ESCON Generation Assistant 4-12, 4-22  
     controlling adapter overrun errors 24-14  
     fallback and switchback 3-8  
     frame-relay resources 16-1, 16-12, 16-21, 16-72, 16-85  
     ISDN resources 7-1  
     SDLC lines  
         Converting IBM 3745 SDLC lines 5-21  
         LPDA tests 23-5, 23-6  
         SDLC lines 3-6, 5-1  
         X.21 lines 5-6, 12-29  
     shared ESCON resources 3-7  
     shared frame-relay resources 3-7  
     shared Token-Ring resources 3-7

CSSTIER keyword 3-2

CTERM keyword 5-31

CU keyword 20-5  
     EP 21-14

CUID keyword 5-30

CUIDLEN keyword 5-31, 18-4

customization  
     channel control code 13-4  
     entry points and library member names 13-5  
     library members that contain linkage editor statements 13-6  
     NDF standard attachment facility 13-8  
     network addressable unit (NAU) 13-4  
     programmed resources 13-3  
     user line control 13-1

CUTOFF keyword 24-7

CUTYPE keyword 5-27, 20-6  
     EP 21-14

CWALL keyword 24-3

## D

D-channel  
     See integrated services digital network (ISDN), physical lines

data  
     characteristics 5-43  
     collection 24-16  
     flow control 24-3  
     mode 24-8  
     sets 2-6  
     structures 22-2  
     traces 22-1  
     transfer 24-6

data carrier detect

data link connection identifier (DLCI) 16-68  
     definition of term 16-5  
     for frame handlers 16-59, 16-67, 16-69  
     for peripheral links 16-46  
     for subarea links 16-32  
     general description 16-2  
     sharing between NCP and 3746 Model 900 3-7

data printing, defining (EP) 21-10

data terminal equipment (DTE)  
     definition of term 16-5

data tracing, defining (EP) 21-10

data-link  
     nonswitched  
         defining 5-1  
         SSCP monitor mode 5-12  
     switched  
         defining 5-4  
         devices 5-30  
         modems 23-15  
         shared port identification 5-11  
         V.25 bis 5-7

DATABLK keyword 6-10, 7-6, 15-32, 15-46, 16-11, 16-33, 16-49, 16-64

datagrams  
     routing to a subnetwork 1-22

## Index

- datagrams (*continued*)
  - routing to internet hosts 15-1
  - using ARP to route 15-28, 15-35
- DATE keyword 9-3
- DATEFMT keyword 9-3
- DATETIME definition statement
  - keywords
    - DATE 9-3
    - DATEFMT 9-3
    - INSERT 9-3
    - PT2EXEC 9-3
    - TIME 9-3
  - usage and position 1-24
- DATMODE keyword 24-8
- DATRATE keyword 5-22, 17-5, 23-7, 23-11
  - EP 21-15
- deactivating an out-of-sequence VR 23-18
- defining
  - EPSA 21-3
    - resources to EPSA 21-3
- defining nonswitched frame-relay physical lines 16-8
- defining session pacing 24-6
- defining switched frame-relay physical lines 16-18
- definition statement sequence and usage 1-8
- definition statement sequence, LINE 21-7
- definition statements
  - BUILD
  - GENEND
  - generation delimiter 21-8
  - GROUP
  - LINE
    - network configuration 21-4
    - process control 21-4
- definition statements, coding
- definition statement
  - system 21-3
- DELAY keyword 4-3, 4-6, 4-16, 15-20, 15-23, 20-4
  - EP 21-21
- delayed logical link activation 6-22, 6-31
- DELETE definition statement
  - keywords 10-1
  - usage and position 1-26
- DESTADDR keyword 15-55
- destination service access point (DSAP)
  - frame relay i, 16-52
  - ISDN i, 7-23
  - Token Ring i, 6-26
- DESTSA keyword 11-4, 12-18, 12-27, 14-16
- devices
  - address trace 23-2
  - branch trace 23-2
  - BSC
    - automatic network shutdown 25-3
    - emulation mode 20-1
    - EP 21-14
    - VTAM 5-33
- devices (*continued*)
  - buffered 5-46
  - channel adapter IOH trace 23-1
  - channel adapter trace 23-1
  - data printing 22-2
  - data tracing 22-1
  - emulation mode 20-5
  - global tracing 22-2
  - line trace 23-2
  - link problem determination aid (LPDA) 23-4
  - nonswitched telecommunication link 5-26, 5-33
  - NTRI snap trace 23-2
  - online tests 23-3
  - parameter tracing 22-1
  - procedure tracing 22-1
  - scanner interface trace 23-2
  - SDLC
    - logical unit addresses 5-36
    - VTAM 5-36
  - SS
    - start-stop emulation mode 20-1
    - switched telecommunication link 5-30
    - TIC internal trace 23-2
- diagnostic aids
  - defining for EP 21-9
- dial digits, defining to VTAM 6-25, 7-22, 16-51
- DIAL keyword 5-6, 5-8, 7-6, 7-11, 7-15, 7-19, 12-14, 12-31
  - EP 21-15
- DIALALT keyword 5-5, 5-25
- DIALNO keyword 5-31, 6-25, 16-51
- DIALSET definition statement
  - keywords
    - DIALALT 5-5
    - LINES 5-5
    - QLIMIT 5-5
    - QLOAD 5-5
    - RESERVE 5-5
  - usage and position 1-13
- DIALSET keyword 5-6, 5-31
- DIALTO keyword 24-10
- digital time unit 21-1
- DIO (dynamic input/output) 10-7
- DISABLE keyword 20-4
  - EP 21-15
- disable timeout 21-15
- DISCNT keyword of VTAM 5-33
- DISP keyword 15-55
- DLCADDR keyword of VTAM 6-25, 7-22, 16-51
- DLCI (data link connection identifier) 16-13, 16-68
  - connection balancing 16-14
  - definition of term 16-5
  - for frame handlers 16-59, 16-67, 16-69
  - for peripheral links 16-46
  - for subarea links 16-32
  - general description 16-2

- DLCI (data link connection identifier) *(continued)*
    - sharing between NCP and 3746 Model 900 3-7
  - DLCI definition statement 1-17, 16-13
    - keywords
      - BALANCE 16-14
      - CIR 16-13
      - ID 16-13
  - DLOGMOD keyword of VTAM 5-33
  - DPU keyword 2-19
  - DR3270 keyword 10-5
  - DRDS (dynamic reconfiguration data set) 10-1
  - DSABLTO keyword 24-10
  - DSAP (destination service access point)
    - frame relay i, 16-52
    - ISDN i, 7-23
    - Token Ring i, 6-26
  - DSRTO keyword 20-7
  - DTE (data terminal equipment)
    - definition of term 16-5
  - dual communication interface feature 21-18
  - dual-code feature 21-17
  - dual-rate modem 21-15
  - DUALCOM keyword 20-3
    - EP 21-18
  - duplex
    - facility 21-4
  - DUPLEX keyword 5-2, 12-7, 12-32
    - EP 21-15
  - duplicate TIC addresses 6-16
    - sample definition 6-17, 6-18
  - DYNADMP keyword 4-3, 4-6, 15-20, 20-2
    - EP 21-13
  - dynamic control facilities 4-28
  - dynamic dump (EP)
  - dynamic input/output (DIO) 10-7
  - dynamic internet routing 15-7
  - dynamic network identification 1-23, 14-18
  - dynamic path update 11-13
  - dynamic reconfiguration
    - adding an internet interface 10-6
    - adding and deleting devices 10-2
    - adding and deleting logical units 10-4
    - defining 10-1
    - for frame-relay devices 10-5, 10-6, 16-59, 16-61
    - for SDLC type 1 physical unit 3720 devices 10-5
    - independent logical unit 8-3
    - pools, increasing size for independent logical units 8-1
    - using a dynamic reconfiguration data set 10-1
  - dynamic reconfiguration data set (DRDS) 10-1
  - dynamically created control blocks 2-10
  - DYNNSC keyword 2-11
  - DYNNSX keyword 2-11
  - DYNPOOL keyword 2-11
  - DYNWIND keyword 6-43, 7-7, 16-15, 16-35
- ## E
- echo detection, frame relay 16-17
  - ECHO, on the NEWDEFN keyword 2-2, 6-27
  - ECLTYPE keyword 6-4, 6-5, 6-30
  - EDIT definition statement
    - keywords 9-2
    - usage and position 1-24
  - edit routine 9-2
  - ELEMENT keyword 14-9
  - emulation mode
    - character transmission 20-7
    - control units 20-5
    - data characteristics 20-6
    - devices 20-5
    - full data multiplex modem example 23-14
    - modems 20-4
    - SNA network interconnection 14-3
    - subchannel 20-1
      - priority 21-16
    - switched telecommunication links 20-4
    - telecommunication links 20-3
    - timeouts 20-7
    - WTTY terminals 20-4
  - Emulation Program standalone (EPSA) 21-1—21-22
  - emulation subchannel priority
    - in LINE definition statement 21-4
  - ENABLTO keyword 24-10
  - end of transmission 5-45, 21-21
  - ENDAUTO definition statement 1-22, 2-13, 2-16
  - ENDBH definition statement
    - description 9-2
    - usage and position 1-25
  - ENDTRNS keyword 5-45
  - Enterprise Systems Connection (ESCON)
    - 3745 ESCON Generation Assistant 4-12, 4-22
    - converting channel links 4-18
    - defining channels for IP 15-22
    - defining logical lines 4-14
    - defining physical lines 4-13
    - defining resources 4-9
    - overview 4-11
  - ENTRY keyword 9-3
  - entry points 13-5
  - EOB keyword 20-4
    - EP 21-21
  - EOT keyword 20-4
    - EP 21-21
  - EP
    - buffers 21-14
    - defining resources 21-8
    - generation source program 21-3
      - details 21-3
  - EP standalone 21-1
  - EPSA
    - defining resources 21-3

## Index

- EPSA (Emulation Program standalone) 21-1—21-22
    - migrating to new release 2-19
  - ER0–ER15 keywords 11-4, 12-18, 12-27, 14-16
  - ERLIMIT keyword 11-4, 14-4, 14-16
  - error recovery
    - between NCPs 12-5
    - NTRI 6-23, 6-31
    - recording 25-4
  - ERRORT keyword 7-8, 16-16
  - ESCD (ESCON Director) 4-9
  - ESCON (Enterprise Systems Connection)
    - 3745 ESCON Generation Assistant 4-12, 4-22
    - converting channel links 4-18
    - defining channels for IP 15-22
    - defining logical lines 4-14
    - defining physical lines 4-13
    - defining resources 4-9
    - overview 4-11
  - ESCON Director (ESCD) 4-9
  - ESS adapters 15-25
    - Ethernet-type LAN attachments 15-25
    - internet addresses 15-25
    - multicasting with 15-25
    - performance 15-59
  - ETHERNET keyword 15-25
  - Ethernet Version 2.0 15-1
  - Ethernet-type LAN
    - connections 15-25
    - in local area networks 15-1
    - interfaces 15-25
    - NDF additions for 15-27
  - ETRATIO keyword 25-4
  - examples, coding
    - See coding examples
  - excessive buffer usage alert 23-19
  - EXEC keyword 9-4, 9-6
  - explicit route
    - assigning 11-11, 14-17
    - defining 11-4
    - guidelines for defining 11-3
    - interconnected network 14-15
    - specifying for MTLG 12-18, 12-27
  - extended LPDA-2 capability 23-5, 23-10
  - extended network addressing 4-26, 14-4
  - extended recovery facility (XRF) 25-6
- F**
- fallback 3-2
    - for 3746 Model 900 resources 3-8
    - for EP resources 3-5
    - for IBM special products or user-written code 3-6
    - for NCP resources 3-3
  - FANOUT keyword 5-28
  - FASTRUN keyword 2-5, 21-10
  - FEATUR2 keyword 5-33
  - FEATURE keyword 5-27, 5-28, 20-5
    - EP 21-17, 21-20, 21-21
  - FECN (forward explicit congestion notification)
    - indicator 16-60
  - forward explicit congestion notification (FECN)
    - indicator 16-60
  - frame handler subport (FHSP)
    - adding through dynamic reconfiguration 16-61
    - defining FHSPs 16-15
    - defining paths between FHSPs 16-57
    - defining substitute FHSPs 16-61
    - definition of term 16-5
  - frame relay
    - 3746 Model 900 support 16-12, 16-21, 16-72, 16-85
    - activating a remote NCP over a frame-relay line 16-73
    - attachments for IP, defining 15-44
    - backup over an ISDN 16-22
    - BAN subarea link
      - conceptual discussion 16-29
      - sample definition 16-43
    - congestion
      - indicators (FECN and BECN) 16-60
      - relieving by discarding frames 15-46, 16-32, 16-49, 16-65
    - converting SDLC subarea links to frame relay 16-38
    - data link connection identifier (DLCI)
      - definition of term 16-5
      - for frame handlers
      - for peripheral links 16-46, 16-59
      - for subarea links 16-32
      - general description 16-2
    - definition statements for resources 7-4, 16-7
    - DLCIs 16-13
    - dynamic reconfiguration 10-5, 10-6, 16-59, 16-61
    - echo detection 16-17
    - frame handler subport (FHSP)
      - adding through dynamic reconfiguration 16-61
      - defining FHSPs 16-15
      - defining paths between FHSPs 16-57
      - defining substitute FHSPs 16-61
      - definition of term 16-5
    - frame size, determining maximum 6-41, 16-12
    - frame-relay frame handler (FRFH) 16-1
      - defining connections for 16-57
      - definition of term 16-5
      - example 16-62, 16-78, 16-81
      - subports (FHSPs) 16-5, 16-15
    - frame-relay switching equipment 16-1
    - frame-relay terminating equipment (FRTE) 16-1
      - definition of term 16-5
      - for peripheral links 16-49
      - for subarea links 16-32, 16-36
      - subports (TESPs) 16-5, 16-32, 16-36, 16-49

- frame relay (*continued*)
    - inactivity timer (TI) 16-13
    - IP attachments 15-44
    - leased lines 16-7
    - link-station subport 16-6, 16-8, 16-15
    - LMI subport 16-6, 16-8, 16-16, 16-69
    - loading a remote NCP over a frame-relay line 16-73
    - local management interface (LMI) protocol 16-6, 16-8, 16-16, 16-69
    - logical lines
      - definition of term 16-6
      - for peripheral links 16-45
      - for subarea links 16-27
    - microcode levels for HPTSS lines 16-10
    - NDF-added keywords
      - for logical peripheral lines 16-53
      - for logical subarea lines 16-37
      - for physical lines 16-20
    - NEWDEFN file 16-9
    - nonswitched physical lines, defining 16-8
    - NTRI attachments, defining 16-63
    - overview
      - advantages of frame relay 16-4
      - general 16-1
      - NCP frame-relay functions 16-2
      - terminology 16-5
    - peripheral links
      - defining 16-45
      - defining peripheral device addresses to VTAM 16-51
      - example 16-54
      - NDF-added keywords 16-53
    - permanent virtual circuit (PVC)
      - definition of term 16-6
      - external PVC segments 16-6, 16-27, 16-45
      - general description 16-2
      - internal PVC segments 16-6, 16-57
    - physical lines
      - defining 16-8
      - definition of term 16-5
      - example 16-21
      - NDF-added keywords 16-20
      - switched 16-18, 16-93
    - physical links for IP 15-44
    - port 16-5
    - remote loading and activation over a frame-relay line 16-73
    - sample configurations and definitions
      - BAN subarea link 16-43
      - frame handler 16-62, 16-78, 16-81
      - peripheral link 16-54
      - physical line 16-21
      - subarea link 16-42, 16-77
    - snap trace diagnostic aid 23-2
    - subarea links
      - converting SDLC subarea links to frame relay 16-38
  - frame relay (*continued*)
    - subarea links (*continued*)
      - defining 16-27
      - example 16-42, 16-77
      - NDF-added keywords 16-37
    - subports
      - definition of term 16-5
      - frame handler subport (FHSP) 16-5, 16-15
      - general description 16-2
      - terminating equipment subport (TESP) 16-5, 16-32, 16-36, 16-49
    - substitute FHSPs, defining 16-61
    - switched physical lines
      - switched physical lines, defining 16-18
    - terminology 16-5
    - TESP (terminating equipment subport)
      - definition of term 16-5
      - for peripheral links 16-49
      - for subarea links 16-32, 16-36
    - TI (inactivity) timer 16-13
    - transmission window size 16-15, 16-35
  - FRAMECNT keyword 15-25
  - FRAMING keyword 18-1
  - free buffer pool 24-2
  - FRELAY keyword 16-10, 16-31, 16-48
  - FRFH
    - See frame relay, frame-relay frame handler (FRFH)
  - FROM keyword 10-1
  - FRRATES keyword 16-11
    - not valid for 3746 Model 900 16-11, 16-73
    - relationships with COMRATE, DATABLK 16-76
  - FRSEDRPU keyword 10-6, 16-59
  - FRSESET definition statement 1-21, 16-61
  - FRTE
    - See frame relay, frame-relay terminating equipment (FRTE)
- ## G
- gateway NCP
    - interconnected networks 14-1
    - native network 14-2
    - non-native network 14-4
    - session accounting 14-24
  - gateway session accounting 14-24
  - GENEND definition statement
    - EP 21-8
    - keywords
      - INCHI 13-5, 13-7
      - INCINIT 13-7
      - INCL2HI 13-7, 24-19
      - INCL2LO 13-7
      - INCLO 13-7
      - INIT 13-5
      - KEY0INC 13-7
      - KEY0ORD 13-7
      - ORDHI 13-7

## Index

### GENEND definition statement (*continued*)

#### keywords (*continued*)

ORDINIT 13-7  
ORDL2HI 13-8, 24-19  
ORDL2LO 13-8  
ORDLO 13-7  
SRCHI 13-6  
SRCLO 13-6  
TMRTICK 13-6  
UACCTNG 13-6, 24-19  
UGLOBAL 13-6

usage and position 1-25

#### generation

characteristics, defining to EP 21-8  
delimiter definition statement 21-8  
keywords ignored by SSP Version 4 21-9  
process control 21-4

#### generation characteristics

defining member name for link-edit control statements 21-8, 21-9

#### generation definition

data printing, EP 21-10  
data tracing, EP 21-10  
delimiter statement 1-7  
in reusable NEWDEFN file 2-3  
parameter tracing, EP 21-10  
procedure tracing, EP 21-9  
sequence 1-8  
verifying 2-5, 2-6

generation process control definition statement 1-5

GENILU keyword 8-9

GENLEVEL keyword 2-5

global tracing 22-2

GP3174 keyword 5-42

G POLL keyword 5-41

### GROUP definition statement

EP 21-4

#### keywords

ACTIVTO 7-15, 12-6, 12-14, 12-31  
ADAPTER 6-7, 15-31, 15-40, 16-64  
AUTOGEN 6-22, 7-15, 7-19, 16-48  
CAEXIT 13-5  
CCLID 5-6  
CHANLNK 13-5  
CHAREC 18-1  
COMPACB 13-2  
COMPOWN 3-6, 13-2  
COMPSWP 6-16, 13-2  
COMPTAD 3-6, 13-2  
CRETRY 25-4  
DELAY 20-4  
DIAL 5-6, 5-8, 7-6, 7-11, 7-15, 7-19, 12-14, 12-31  
DSRTO 20-7  
ECLTYPE 6-4, 6-5, 6-30  
EOB 20-4  
EOT 20-4

### GROUP definition statement (*continued*)

#### keywords (*continued*)

ETHERNET 15-25  
FRAMING 18-1  
FRELAY 16-10, 16-31, 16-48  
ISDN 7-6, 7-11, 7-15, 7-19  
KBDLOCK 18-1  
LANTYPE 15-26  
LEVEL2 13-2  
LEVEL3 13-2  
LEVEL5 13-2  
LINEADD 13-2  
LINEAUT 7-15, 7-19, 12-14, 13-2  
LNCTL 4-2, 4-13, 4-15, 5-1, 5-8, 12-27, 15-22  
LNKOWNER 13-8  
LOCALTO 6-45, 16-36  
LSPRI 6-10, 16-12, 24-21  
MAXBFRU 4-3, 4-6, 4-16, 15-21, 15-23  
MODE 7-15, 12-6, 12-31  
NCST 15-9  
NETID 6-30, 12-14  
NPACOLL 24-17  
NPARSC 24-17  
PADCNT 19-1  
PECHAR 18-1  
PHYSRSC 4-15, 6-22, 6-31, 7-11, 7-15, 7-19, 15-23, 16-31, 16-48, 16-67  
PRODID 5-8  
PUTYPE 12-14  
QUIETCT 20-7  
REMOPTO 6-45  
REPLYTO 24-4  
RETRYTO 5-6  
RNRLIMIT 5-2, 5-38, 6-23, 12-6  
TEXTTO 24-4  
TIMER 13-2  
TTDCNT 24-11  
TYPE 5-2  
USERID 13-2  
V25DIAL 20-7, 21-15  
VIROWNER 13-8  
VIRTUAL 13-3  
WACKCNT 24-11  
WAKDLAY 24-11  
WTTYEOB 19-1  
WTTYEOT 19-1  
X21SW 5-6  
XIO 13-2  
XMITDLY 5-6, 8-3  
stand-alone 12-8  
usage and position 1-15  
used to define channels 4-1  
GROUP keyword 7-14, 12-4, 16-30, 17-6  
group polling 5-42  
GWAEXIT keyword 14-24

GWNAU definition statement  
 keywords  
   ELEMENT 14-9  
   NAME 14-9  
   NETID 14-9  
   NUMADDR 2-10, 14-9  
   NUMSESS 14-10  
 placement 14-12  
 usage and position 1-10, 1-23  
 GWSESAC keyword 2-11, 14-25

## H

half-duplex facility 21-4  
 half-session control blocks (HSCBs) 14-10  
 hardcopy library, NCP, SSP, and EP xxxiii  
 Hardware Configuration Definition (HCD) 10-7  
 HCD (Hardware Configuration Definition) 10-7  
 HDWADDR keyword 15-29, 15-36  
 HDXSP keyword 5-39, 12-32  
 hello datagrams, Internet Protocol 15-7  
 HICHAN keyword 4-3, 4-6, 15-20, 20-2  
   EP 21-11  
 high-speed transmissions, performance  
   improvement 24-7  
 HISPEED keyword 5-3, 16-12  
 HONE Configurator 2-19  
 HOST definition statement  
   usage and position 1-10  
 HOSTADDR keyword 15-7  
 HOSTLINK keyword 4-15, 4-18, 4-19, 4-21, 4-22,  
   15-23  
 HOSTRT keyword 15-55  
 How to Generate a Minimum-Sized Load Module 2-6  
 HPRSNAP keyword 8-19  
 HSBPOOL keyword 2-10, 14-3, 14-11  
 HSCB pools 14-11  
 hypertext links xxxiii

## I

I/O Configuration Program (IOCP) 4-12  
 ID keyword 5-11, 7-11, 16-13  
 IDLIST definition statement  
   keywords  
     IDSEQ 5-31, 18-3  
     MAXLEN 5-31, 18-3  
     NOMATCH 5-31, 18-3  
   usage and position 1-11  
 IDNUM keyword 5-13, 7-33  
 IDSEQ keyword 5-31, 18-3, 18-4  
 IEEE (Institute of Electrical and Electronic Engineers)  
   standard 802.3 15-1  
 implicitly defined internet routes 15-53  
 inactivity timer (TI)  
   frame-relay 16-13

inactivity timer (TI) (*continued*)  
   Token-Ring 6-46  
 INBFRS keyword 4-3, 4-6, 15-20  
 INCHI keyword 13-7  
 INCINIT keyword 13-7  
 INCL2HI keyword 13-7  
 INCL2LO keyword 13-7  
 INCLO keyword 13-7  
 increased explicit route capability 11-15  
 independent logical unit  
   as cross-domain resource 8-6, 8-9  
   automatic definition 8-2  
   boundary session control blocks 8-8  
   building control block pools 8-10  
   dynamic reconfiguration 8-3  
   ignoring 8-9  
   multiple and parallel session diagram 8-7  
   processing 8-1  
   reserved boundary session control blocks 8-4  
   specifying 8-4  
 INHIBIT keyword 24-12, 24-13  
 INIT keyword 13-5  
 initial inhibition of NCP functions 24-12  
 input/output configuration data set (IOCDS)  
   CNTLUNIT definition statement 4-22  
   generation definition 4-22  
   IODEVICE definition statement 4-22  
   LINK keyword 4-22  
   UNITADD keyword 4-18, 4-22  
 INSERT keyword 9-3  
 Institute of Electrical and Electronic Engineers (IEEE)  
   standard 802.3 15-1  
 integrated services digital network (ISDN)  
   B-channels  
     controlling setup for dial-out connections 7-28  
     defining 7-10  
     definition of term 7-3  
     example 7-12  
     NDF-added keywords 7-12  
   D-channels  
     See integrated services digital network (ISDN),  
       physical lines  
   establishing a connection 7-26  
   logical lines  
     defining device addresses to VTAM 7-22  
     for peripheral links 7-18  
     for subarea links 7-13  
   NDF-added keywords  
     for B-channels 7-12  
     for logical peripheral lines 7-21  
     for logical subarea lines 7-18  
     for physical lines 7-10  
   overview  
     advantages of ISDN 7-3  
     general 7-1  
     terminology 7-3

## Index

- integrated services digital network (ISDN) (*continued*)
  - peripheral links
    - defining 7-18
    - example 7-21
    - NDF-added keywords 7-21
  - physical lines
    - defining 7-5
    - definition of term 7-3
    - example 7-10
    - NDF-added keywords 7-10
  - sample configurations and definitions
    - B-channels 7-12
    - peripheral link 7-21
    - physical line 7-10
    - subarea link 7-18
  - subarea links
    - defining 7-13
    - example 7-18
    - NDF-added keywords 7-18
    - through TA or BAN 7-31
  - terminology 7-3
- interconnected networks 14-1
- interframe gap 24-14
- internal NCP to Model 900 point-to-point IP connection 15-39
- internet interface 10-6
- Internet Protocol (IP)
  - addresses
    - classes A, B, and C 15-5
    - format 15-4
    - host 15-6
    - network 15-5
    - subnetwork 15-6
  - broadcasts 15-5
  - channel attachments, defining 15-18
  - datagrams 15-9
  - Ethernet-type LAN connections 15-25
  - frame-relay attachments, defining for IP 15-44
  - hardware addresses of internet hosts 15-28
  - hello datagrams 15-7
  - implicitly defined routes 15-53
  - interfaces
    - Ethernet-type LAN 15-25
    - NCST 15-8
    - NTRI 15-31
    - summary 15-2
  - NCST logical units 15-8
  - NEWDEFN file 2-1
  - NTRI connections 15-31
  - overview 15-1
  - permanent internet host 15-28, 15-35
  - resource definition examples 15-60
  - route tables 15-7
  - routing
    - defining 15-52
    - dynamic 15-7
    - Ethernet-type LAN connections 15-2
- Internet Protocol (IP) (*continued*)
  - routing (*continued*)
    - interfaces 15-28, 15-35
    - NCST 15-2
    - NTRI connections 15-2
    - subnetwork addressing 15-6
  - internet route definitions, coding for best performance 15-59
  - INTERFACE keyword 15-7, 15-9, 15-10, 15-21, 15-24, 15-27, 15-34, 15-42, 15-48, 15-55
  - IOCDS (input/output configuration data set)
    - CNTLUNIT definition statement 4-22
    - generation definition 4-22
    - IODEVICE definition statement 4-22
    - LINK keyword 4-22
    - UNITADD keyword 4-18, 4-22
  - IP (Internet Protocol)
    - See Internet Protocol (IP)
  - IP channel interface 15-8
  - IPADDR keyword 15-29, 15-36
  - IPHOST definition statement
    - description 15-28, 15-36
    - keywords
      - HDWADDR 15-29, 15-36
      - IPADDR 15-29, 15-36
      - LANTYPE 15-29
    - usage and position 1-21
  - IPL keyword 6-31, 7-15, 16-31
  - IPLOCAL definition statement 15-49
    - description 15-10, 15-27, 15-34, 15-42
    - keywords 15-49
      - INTERFACE 15-10, 15-21, 15-24, 15-27, 15-34, 15-42, 15-48
      - LADDR 15-10, 15-27, 15-35, 15-42, 15-48
      - METRIC 15-10, 15-27, 15-35, 15-42, 15-49
      - P2PDEST 15-11
      - PROTOCOL 15-11, 15-27, 15-35, 15-43, 15-49
      - SNETMASK 15-11, 15-27, 15-35, 15-43, 15-49
    - usage and position 1-22
  - IPOWNER definition statement
    - description 1-22
    - keywords
      - HOSTADDR 15-7
      - INTERFACE 15-7
      - IONUMDR 2-11
      - MAXHELLO 15-7
      - NUMDRIF 2-11
      - NUMROUTE 2-11, 15-7
      - UDPPORT 15-8
    - usage and position 1-22, 15-7
  - IPPOOL keyword 15-59
  - IPRATE keyword 15-59
  - IPROUTE definition statement
    - description 15-55
    - keywords
      - DESTADDR 15-55
      - DISP 15-55



IPROUTE definition statement (*continued*)keywords (*continued*)

HOSTRT 15-55

INTERFACE 15-55

METRIC 15-55

NEXTADDR 15-56

usage and position 1-22

IPSNAP keyword 15-59

IRETRY keyword 12-33, 25-5

## ISDN

See integrated services digital network (ISDN)

ISDN keyword 7-6, 7-11, 7-15, 7-19, 7-35

ISDNCALL keyword 16-23

ISDNCFG keyword 7-8

ISDNDSCT keyword 7-8

ISDNLPN keyword 7-6, 16-23

ISDNLSA keyword 7-6, 16-23

ISDNRPN keyword 16-23

ISDNRSA keyword 16-23

ISTATUS keyword of VTAM 5-33

ITBMODE keyword 5-44

ITEXTTO keyword 24-11

**J**

JOB CARD keyword

**K**

KBDLOCK keyword 18-1

KEY0INC keyword 13-7

KEY0ORD keyword 13-7

keywords, ignored by SSP Version 4

keywords, lower level on higher level definition statements 1-7

**L**

LADDR keyword 15-10, 15-27, 15-35, 15-42, 15-48

LANTYPE keyword 15-26

LCST keyword 17-3, 17-4, 17-6, 17-7

LCTYPE keyword 17-3, 17-4, 17-6, 17-7

legal notices xxiii

## LEN

composite type 2.1 node 8-13

generating 8-14

LENAME keyword 2-6

EP 21-9

LESIZE keyword

LEVEL2 keyword 13-2

LEVEL3 keyword 13-2

LEVEL5 keyword 13-2

LGRAPHS keyword 5-28

library member names 13-5

library members that contain Linkage Editor statements 13-6

library, NCP, SSP, and EP

hardcopy library xxxiii

hypertext links xxxiii

softcopy library xxxv

license agreement xxiii

licensing agreement, IBM

limited resources 5-10

LIMRES keyword 5-11

line control

BSC 21-19

EP 21-12

LINE definition statement

EP 21-4

keywords

ADDIFG 24-14

ADDRESS 2-16, 4-2, 4-5, 4-13, 4-15, 4-21, 5-2, 6-8, 7-6, 7-11, 7-15, 13-5, 15-19, 15-23, 15-25, 15-32, 15-41, 16-10, 16-64, 20-2

ANS 25-3

ANSTONE 16-19, 23-15

AUTO 5-6, 5-8, 23-16

AUTOCOPY 2-12, 7-11, 7-15, 7-19

AUTODL 5-6

AUTOLINE 2-16

AUTUACB 13-3

AVGPB 5-38

BEACTO 6-10, 15-32, 15-41, 16-64

BUFETTE 20-6

CA 4-2, 4-13, 4-15, 4-21, 15-22

CALINE 23-6

CALL 5-6, 5-9, 6-23, 7-11

CASDL 4-3, 4-5, 15-20

CCLID 5-6

CHANLA 23-6, 23-11

CHECK 20-4

CHNLZ 5-24, 23-6, 23-11

CHNPRI 20-2

CIR 7-6, 16-10

CLINES 23-7

CLLM 16-11

CLOCKNG 5-2, 16-11

CODE 5-43

CONFIG 12-7

CORNUM 5-24, 23-7, 23-11

CRRATE 5-27

CU 20-5

CUTOFF 24-7

CUTYPE 20-6

DATBLK 6-10, 7-6, 15-32, 15-46, 16-11, 16-33, 16-49, 16-64

DATRATE 5-22, 23-7, 23-11

DELAY 4-3, 4-6, 15-20

DIALALT 5-25

DIALSET 5-6

DISABLE 20-4

DUALCOM 20-3

DUPLEX 5-2, 12-7, 12-32

## Index

### LINE definition statement (*continued*)

#### keywords (*continued*)

DYNADMP 4-3, 4-6, 15-20, 20-2  
DYNWIND 6-43, 7-7, 16-15, 16-35  
ETRATIO 25-4  
FEATURE 20-5  
FRAMECNT 15-25  
FRRATES 16-11  
HDXSP 5-39, 12-32  
HICHAN 4-3, 4-6, 15-20, 20-2  
HISPEED 5-3, 16-12  
HOSTLINK 4-15, 4-18, 4-19, 4-21, 4-22, 15-23  
ID 5-11, 7-11  
INBFRS 4-3, 4-6, 15-20  
INTFACE 15-26, 15-32  
ISDNCALL 16-23  
ISDNLPN 7-6, 16-23  
ISDNLSA 7-6, 16-23  
ISDNRPN 16-23  
ISDNRSA 16-23  
LIMRES 5-11  
LINECB 13-3  
LINEFVT 13-3  
LINESIZ 5-27  
LNQTCNT 5-3  
LOCADD 6-10, 7-6, 15-26, 15-32, 15-41  
LOCALTO 6-45, 16-32, 16-36, 16-48  
LOCHAN 4-3, 4-6, 15-20, 20-2  
LPDA2DL 23-16  
LPDATS 12-32, 23-5  
LSPRI 6-10, 7-6, 16-12, 24-21  
MAXBFRU 4-3, 4-6, 4-16, 15-21, 15-23  
MAXDLCI 7-6, 7-7, 16-12, 16-17, 16-67, 16-69  
MAXFRAME 6-41, 7-7, 12-26, 16-12, 16-65,  
16-68  
MAXPU 4-15, 10-3, 12-32, 15-41, 16-12  
MAXTSL 6-11, 12-26, 15-32, 15-41, 16-65  
MLTGPRI 6-31, 7-16, 12-18, 16-31  
MODEM 20-5  
MONITOR 5-3, 18-2  
MONLINK 4-3, 4-15, 5-12, 5-14, 5-16, 5-17,  
6-31, 7-16, 16-31  
MPTALT 5-6  
MTALIST 17-7  
NCPA 4-3, 4-6, 15-20  
NEGPOLP 24-11  
NEWSYNC 5-22, 12-32  
NPACOLL 6-11, 6-23, 7-12, 7-16, 7-19, 15-32,  
15-41, 15-60, 16-12, 16-31, 16-48, 16-50, 16-61,  
16-65, 16-68, 24-17, 24-19  
NPATP 24-19  
NRZI 5-22  
PAD 20-6  
PARCHK 18-2  
PARGEN 18-2  
PAUSE 5-39, 24-11  
POLIMIT 5-40

### LINE definition statement (*continued*)

#### keywords (*continued*)

POLLED 5-40  
POLLTO 24-12  
PORT 23-11  
PORTADD 6-11, 7-7, 15-32, 15-41, 16-12  
PROMPT 18-3  
QUIET 20-8  
RCVBUFC 6-11, 6-41, 12-26, 15-32, 16-65,  
16-68, 20-7  
RCVCHAR 20-7  
REDIAL 5-6, 5-9  
REOTTO 6-45  
RETRIES 6-23, 6-31, 7-16, 12-32, 16-32, 16-48,  
16-68, 25-4  
RING 5-9, 23-16  
SDLCST 7-16, 12-7, 16-32  
SECURE 5-7  
SERVLIM 24-5  
SERVPRI 24-12  
SESSION 5-37  
SPDSEL 5-23  
SPEED 5-3, 5-7, 5-23, 7-7, 7-12, 8-20, 16-13  
SRETRY 12-32  
SWMMTID 5-14, 7-33  
T2TIMER 6-42, 6-45, 16-32, 16-36, 16-48  
TADDR 12-7, 12-32  
TAILING 12-32, 23-7, 23-11  
TAKEOVER 21-12  
TERM 20-5  
TIMEOUT 4-3, 4-6, 15-20  
TITIMER 6-46, 7-7, 16-13  
TRANSBUF 16-13  
TRANSFR 4-3, 4-6, 8-3, 12-7, 15-20, 24-2, 24-7  
TRSPEED 6-12, 6-39, 15-33, 15-41  
TYPE 5-3  
UACB 13-3  
UNITXC 20-6, 20-7  
USE 20-3  
V25BIS 5-9  
X21NTWK 5-6  
usage and position 1-16  
line group 21-6  
line pools 6-25, 7-22, 16-50  
line selection  
based on order of activation 12-16  
based on user-defined priority 12-16  
defining priority 12-16  
line test, EP 21-14  
line trace 23-2  
EP 21-13  
LINEADD keyword 13-2  
Linear Connection Balancing 6-9  
linear connection balancing (3745 and  
3746 Model 900) 16-14

- LINEAUT keyword 7-15, 7-19, 12-14, 13-2
- LINECB keyword 13-3
- LINEFVT keyword 13-3
- lines
  - defining for BSC and SS 21-12
- LINES keyword 5-5
- LINESIZ keyword 5-27, 17-3, 17-6
- LINETRC keyword
- link problem determination aid (LPDA) 23-4
- link session priority 6-10, 16-12, 24-21
- link stations 12-1
- link-edit control statements, defining member name for 21-9
- link-station subport, frame relay 16-6, 16-8, 16-15
- links, hypertext xxxiii
- LMI (local management interface)
  - protocol 16-6
  - subports 16-8
- LMI keyword 7-8, 16-16, 16-69
  - NUI option 7-9, 16-20
- LMODADR keyword 23-16
- LNCTL keyword 4-5, 4-13, 4-15, 5-1, 5-8, 12-27, 15-22
  - EP 21-12
- LNKOWNER keyword 13-8
- LNQTCNT keyword 5-3
- load balancing 6-17
- load modules 2-8
- loading and activating a remote controller
  - over frame-relay lines 16-73
  - over ISDN lines 7-32
  - over SDLC and X.21 lines 12-29
  - over Token-Ring lines 6-48
- loading and dumping a channel-attached NCP 4-7
- LOCADD keyword 6-10, 7-6, 15-32, 15-41
- LOCADDR keyword 4-6, 4-17, 5-34, 8-4
- local area networks 15-1
- local management interface (LMI)
  - protocol 16-6
  - subports 16-8
- locally administered address (NTRI) 6-10, 15-26, 15-32
- LOCALTO keyword 6-45, 16-32, 16-36, 16-48
- LOCHAN keyword 4-3, 4-6, 15-20, 20-2
  - EP 21-11
- LOGAPPL keyword of VTAM 5-33
- logical boundary unit, specifying maximum LU-LU sessions 8-9
- logical connections
  - frame relay 16-27, 16-45, 16-57
  - subarea 6-29
  - Token Ring 6-20, 6-21
- logical group, associating with physical unit 6-22, 6-31
- logical line pools 6-25, 7-22, 16-50
- logical lines, defer activation of 6-11, 6-22, 6-31
- logical subarea lines
  - frame relay 16-27
  - ISDN 7-13
  - NCST 15-1
  - peripheral primary 8-8
  - specifying sessions 8-9
  - Token Ring 6-27
- logical unit
  - adding and deleting dynamically 10-4
  - control blocks (LUBs) 5-34, 6-22, 10-4
  - defining as cross-domain resources 8-6, 8-9
  - Ethernet-type LAN 15-1
  - independent 8-1
    - logical unit control blocks 8-8
- logical-connection station 5-29
- LOGTAB keyword of VTAM 5-33
- low-entry networking
  - composite type 2.1 node 8-13
  - generating 8-14
- lower level keywords on higher level definition statements 1-7
- LPDA (link problem determination aid) 23-4
- LPDA keyword 23-4
- LPDA-1 (migration mode) 23-6
- LPDA-2
  - 3746 Model 900 lines 23-5, 23-6
  - multiple local modem support 23-16
  - normal mode 23-10
  - on switched lines 23-16
- LPDA2DL keyword 23-16
- LPDATS keyword 12-32, 23-5
- LSPRI keyword 6-10, 7-6, 16-12, 24-21
- LTRACE keyword 23-3
- LU
  - See logical unit
- LU definition statement
  - keywords
    - INTERFACE 15-9
    - LOCADDR 4-6, 4-17, 5-34, 8-4
    - LUCB 13-4
    - LUDR 8-13, 10-5
    - LUFVT 13-4
    - LUNTFY 13-4
    - MAXCOLL 24-18, 24-19
    - MAXSESS 8-4
    - MAXTP 24-19
    - NEXT 2-13
    - NPACOLL 24-18
    - NUMSESS 13-4
    - PACING 8-5, 24-6
    - REMLU 15-10
    - RESSCB 8-4
    - UCCB 13-5
    - VPACING 5-33, 5-36, 8-5
  - usage and position 1-21

## Index

### LU-LU

- maximum for a single NCP logical boundary
  - unit 8-9
- sessions
  - backups for SDLC devices 25-6
  - cross-network 14-4, 14-8, 14-24
  - independent logical units 8-4, 8-8, 8-9, 8-10, 8-11
  - NCST (network connectionless transport) 15-8, 15-10
- LUB (logical unit control block) 5-34, 6-22, 10-4
- LUCB keyword 13-4
- LUDR keyword 8-13, 10-5
- LUDRPOOL definition statement
  - keywords
    - NUMILU 2-10, 5-34, 8-3, 8-9, 10-4
    - NUMTYP1 2-10, 5-34, 10-4
    - NUMTYP2 2-10, 5-34, 6-22, 10-4
  - usage and position 1-11
- LUFVT keyword 13-4
- LUNTFY keyword 13-4
- LUPOOL definition statement
  - keywords 5-36
  - usage and position 1-11

## M

- maintenance and operator subsystem extended (MOSS-E) 4-12, 4-14, 4-18, 4-21, 4-22
- MASK keyword 18-4
- mask, internet subnetwork 15-6
- MAXBFRU keyword 4-3, 4-6, 4-16, 15-21, 15-23
- MAXCOLL keyword 24-18, 24-19
- MAXDATA keyword 5-13, 6-32, 6-42, 12-7, 12-26, 16-36, 24-8
- MAXDLCI keyword 7-7, 16-12, 16-17, 16-67, 16-69
- MAXFRAME keyword 6-41, 7-7, 12-26, 16-12, 16-65, 16-68
- MAXHELLO keyword 15-7
- maximum transfer unit (MTU) 15-9
- MAXLEN keyword 5-31, 18-3
- MAXLIST keyword 10-3, 12-32
- MAXLU keyword 5-35, 10-4
- MAXOUT keyword 5-13, 6-43, 7-33, 12-4, 16-60, 24-8
- MAXPU keyword 4-15, 10-3, 12-32, 15-41, 16-12
- MAXSESS keyword 8-4, 8-9
- MAXSSCP keyword 4-27
- MAXSUBA keyword 4-26, 14-4
- MAXTP keyword 24-19
- MAXTSL keyword 6-11, 12-26, 15-32, 15-41, 16-65
- MDLENT keyword of VTAM 5-33
- MDLTAB keyword of VTAM 5-33
- MEMSIZE keyword 3-2
- message-ending characters 21-20
- METRIC keyword 15-10, 15-27, 15-35, 15-42, 15-49, 15-55

- migrating to 3746 Model 900 SDLC lines 5-21
- migrating to EP R14 standalone 2-19
- migrating to NCP V7R8 2-9
- migration aid function 2-18
- migration mode (LPDA-1) 23-4, 23-6
- MINILOAD keyword 2-6
- mixed-level network 11-14
- mixed-media MLTG (MMMLTG) 12-16
- MLTG (multilink transmission group)
  - checksum support 24-9
  - line selection priority 12-19
  - mixed-media MLTG (MMMLTG) 12-16
  - segment size 12-23
- MLTGORDR 12-17
- MLTGPRI 6-31, 7-16, 12-18, 16-31
- MMMLTG (mixed-media MLTG) 12-16
- MODE keyword 7-14, 7-15, 12-5, 12-6, 12-31, 16-30, 16-31
- Model 900
  - 3745 ESCON Generation Assistant 4-12, 4-22
  - controlling adapter overrun errors 24-14
  - fallback and switchback 3-8
  - frame-relay resources 16-1, 16-12, 16-21, 16-72, 16-85
  - ISDN resources 7-1
  - SDLC lines
    - Converting IBM 3745 SDLC lines 5-21
    - LPDA tests 23-5, 23-6
    - SDLC lines 3-6, 5-1
    - X.21 lines 5-6, 12-29
  - shared ESCON resources 3-7
  - shared frame-relay resources 3-7
  - shared Token-Ring resources 3-7
- MODEL keyword 3-2
  - EP 21-11
- model networks 14-18
- MODEM keyword 20-5
  - EP 21-16
- modems
  - diagnosing using LPDA 23-4
  - dual-rate 21-15
  - emulation mode LPDA 20-4
  - full-data-multiplex 23-14
  - migration mode (LPDA-1) 23-4
  - normal mode (LPDA-2)
    - defining 23-15
    - IBM 7861 and 7868 modems 23-16
    - LPDA capabilities 23-16
- MODETAB keyword of VTAM 5-33
- MODULO keyword 5-4, 5-42, 8-3, 12-7
- MONITOR keyword 5-3, 18-2
- monitoring
  - control block pools 24-17
  - NCP using NTuneMON 24-1
- MONLINK keyword 4-3, 4-15, 4-16, 5-12, 5-14, 5-16, 5-17, 6-31, 7-16, 16-31

- MOSS extended (MOSS-E) 4-12, 4-14, 4-18, 4-21, 4-22
- MPTALT keyword 5-6
- MSLA (multiple subchannel line access facility) 21-12
- MTA (multiple terminal access) facility  
See multiple terminal access (MTA) facility
- MTALCST definition statement  
keywords  
ACR 17-5  
CLOCKNG 17-5  
CODE 17-3, 17-5  
COMPARE 18-4  
CRRATE 17-5  
DATRATE 17-5  
GROUP 17-6  
LCTYPE 17-3, 17-6  
LINESIZ 17-3, 17-6  
MASK 18-4  
RETRIES 17-6  
SPEED 17-6  
TRANSFR 17-6  
stand-alone 17-6  
usage and position 1-14
- MTALIST definition statement  
keywords 17-3, 17-4, 17-6  
usage and position 1-14
- MTALIST keyword 17-7
- MTAPOLL definition statement  
keywords 17-7  
usage and position 1-14
- MTARTO keyword 24-20
- MTARTRY keyword 24-20
- MTATABL definition statement  
keywords  
CODE 17-4, 17-7  
LCST 17-3, 17-4, 17-7  
LCTYPE 17-4, 17-7  
usage and position 1-14
- MTU (maximum transfer unit) 15-9
- MULTI keyword  
EP 21-19
- multicast packets 15-5
- multilink transmission group (MLTG)  
line selection priority 12-19  
mixed-media MLTG (MMMLTG) 12-16  
segment size 12-23
- multiple subchannel line access facility (MSLA) 21-12
- multiple terminal access (MTA) facility  
device characteristics 17-5  
performance characteristics 24-20  
polling character 17-7  
sign-on procedures 17-1  
table procedures 17-3  
telecommunication links 17-7  
terminal type 17-1, 17-6  
terminals 17-1
- multiple terminal access (MTA) facility (*continued*)  
TWX terminals 18-4
- multipoint line control 21-19
- multipoint subarea link  
coding example 12-11  
defining 12-3  
description 12-2
- MVS/ESA publications X-38
- ## N
- NAME keyword 9-3, 14-9
- NAMTAB keyword 2-7, 2-11, 8-12, 14-3
- native network 14-2
- NAU (network addressable unit) 13-4
- NAUCB keyword 13-4
- NAUFVT keyword 13-4
- NCP  
See Network Control Program (NCP)
- NCP connectionless SNA transport  
connection 15-7, 15-11, 15-21, 15-24
- NCP connectionless SNA transport (NCST)  
coding example to define NCST session 15-12  
logical unit 15-1, 15-8  
NDF additions for 15-11
- NCP migration aid function 2-18
- NCP V7R8, term xxx
- NCP, SSP, and EP library  
hardcopy library xxxiii  
hypertext links xxxiii  
softcopy library xxxv
- NCP/EP definition facility (NDF)  
additions 6-4, 15-11, 15-27, 16-20, 16-37, 16-53  
definition file 2-1  
ESCON adapters 4-12  
frame relay 16-20, 16-37, 16-53  
Token Ring 2-1  
verifying generation definition 2-1
- NCP/Token-Ring interconnection (NTRI)  
See Token Ring
- NCPCA keyword 4-3, 4-6, 15-20
- NCPNAU definition statement  
keywords  
NAUCB 13-4  
NAUFVT 13-4  
NOTIFY 13-4  
NUMSESS 13-4  
TYPE 13-4  
VIOWNER 13-8  
usage and position 1-9
- NCPROUTE program 15-55
- NCPTRACE keyword 23-2
- NCST (NCP connectionless SNA transport)  
coding example to define NCST session 15-12  
connection 15-7, 15-11, 15-21, 15-24  
logical unit 15-1, 15-8

## Index

- NCST (NCP connectionless SNA transport) (*continued*)
  - NDF additions for 15-11
- NCST keyword 15-9
- NDF (NCP/EP definition facility)
  - See NCP/EP definition facility (NDF)
- NDF standard attachment facility 13-8
- NDNAME keyword 2-2
- NEGPOLP keyword 24-11
- NETDA (IBM Network Design and Analysis) 11-15
  - V1R3 support B-1
- NETID keyword 2-7, 4-16, 5-13, 7-17, 7-33, 8-3, 8-12, 12-14, 14-6, 14-9, 16-36
- NETLIM keyword 14-11
- NetView Performance Monitor (NPM)
  - basic data collection 24-16
  - data collection by transmission priority 24-18
  - performance data collection
    - 3746 Model 900 SDLC lines 5-7
    - ESCON links 4-16
    - ESCON physical lines 4-13
    - Ethernet-type LAN 15-60
    - frame-relay connections 16-13, 16-59, 16-61
    - gateway cross-network sessions 14-24
    - ISDN accounting 7-34
    - nonswitched telecommunication links 5-2, 5-3
    - overview 24-16
    - SDLC subarea links 12-7
    - session accounting 24-15
    - Token-Ring connections 6-11, 6-23, 15-32, 16-65, 16-68
- NetView publications X-36
- network configuration definition statements 1-6
- Network Control Program (NCP)
  - adjacent NCPs 14-5
  - attention signals to channels 4-3, 4-6, 4-16, 15-20, 15-23
  - buffer size 2-11, 12-26, 24-1
  - casual connection 8-1, 12-29
  - communication controllers 3-1
  - data characteristics 5-43
  - data collection by transmission priority 24-18
  - defining resources 1-4
  - defining to VTAM 4-29
  - determining primary and secondary status 12-4
  - error recovery 12-5
  - ESCON resources 4-9
  - Ethernet-type LAN resources 15-1
  - frame-relay resources 16-1
  - gateway and interconnected networks 14-1
  - ISDN resources 7-1
  - link stations 12-1
  - loading and dumping 12-29
  - native network 14-2
  - NCP connectionless SNA transport (NCST) logical unit 15-8
  - non-native network 14-2, 14-4
- Network Control Program (NCP) (*continued*)
  - non-native network attachment 8-3, 8-12, 12-30
  - power-off feature 12-28
  - primary state 12-5
  - resource definition overview 1-1
  - secondary state considerations 12-6, 16-31
  - SSCP sessions 4-27
  - states 12-5, 12-6
  - subarea address 2-8, 4-26
  - subarea links 12-1
  - switched subarea connections 12-13
  - Token-Ring resources 6-1
  - transferring data 24-2
  - transmission delay 8-3
  - type 2.1 peripheral node 8-1
- NETWORK definition statement
  - keywords
    - ACTPU 14-4
    - COPIES 14-4, 14-18
    - ERLIMIT 11-4, 14-4, 14-16
    - MAXSUBA 14-4
    - NETID 14-4
    - NETLIM 14-11
    - NUMHSAS 14-4
    - PATHEXT 11-13
    - SALIMIT 4-26
    - SESSLIM 14-11
    - SUBAREA 14-5
    - TGTIMER 23-19
    - VRTIMER 23-18
  - usage and position 1-22
- Network Design and Analysis (NETDA) 11-15
  - V1R3 support B-1
- NETWORK keyword 6-13, 15-34, 15-42, 16-66
- network names table entries 2-7, 8-12, 14-3
- network performance analyzer (NPA)
  - basic data collection 24-16
  - by transmission priority 24-18
  - defining 24-16
  - Ethernet-type LAN resources 15-60
  - frame-relay resources 16-12, 16-18, 16-31, 16-48, 16-61, 16-68
  - session accounting 14-25, 24-15
  - Token-Ring resources 6-11, 6-23, 15-32, 15-41, 16-65, 16-68
- Network Traffic Analyzer service 11-15
- networks
  - address control blocks 14-8
  - backup 5-25
  - cross-network path
    - overview 14-15
    - VTAM 14-23
  - Ethernet-type LAN 15-1
  - half-session control blocks 14-10
  - SNA wide area 15-1
  - with adjacent NCPs 14-5

- new-sync signal 21-17
  - NEWDEFN file 2-1
  - NEWDEFN keyword 2-2, 2-12, 2-16, 6-4, 16-9
  - NEWNAME keyword 2-8
    - EP 21-8
  - NEWPATH keyword 11-14
  - NEWSYNC keyword 5-22, 12-32
    - EP 21-17
  - NEXT keyword 2-13
  - NEXTADDR keyword 15-56
  - NOMATCH keyword 5-31, 18-3
  - non-native network 14-2, 14-4
  - non-native network attachment 8-3, 8-12, 12-30
  - nonswitched frame-relay physical lines, defining 16-8
  - nonswitched telecommunication links
    - defining 5-1
    - devices 5-26, 5-33
    - SSCP monitor mode 5-12
  - NOREUSE, on the NEWDEFN keyword 2-3
  - normal mode (LPDA-1) 23-10
  - NOSUPP on the NEWDEFN keyword 2-2
  - NOTIFY keyword 13-4
  - NOTRDATA keyword 22-2
    - EP 21-10
  - NOTRGLOB keyword 22-3
    - EP 21-10
  - NOTRPARM keyword 22-1
    - EP 21-10
  - NOTRPROC keyword 22-1
    - EP 21-10
  - NPA (network performance analyzer)
    - See network performance analyzer (NPA)
  - NPA keyword 14-25, 24-16, 24-19
  - NPACOLL keyword 4-13, 12-7
    - frame relay 16-12, 16-18, 16-31, 16-48, 16-50, 16-61, 16-65, 16-68
    - internet resources 15-32, 15-41, 15-42, 15-60
    - ISDN 7-12, 7-16, 7-19
    - performance considerations 24-17, 24-18, 24-19
    - Token Ring 6-11, 6-23
  - NPARSC keyword 24-17
  - NPATP keyword 24-19
  - NPM (NetView Performance Monitor)
    - basic data collection 24-16
    - data collection by transmission priority 24-18
    - performance data collection
      - 3746 Model 900 SDLC lines 5-7
      - ESCON links 4-16
      - ESCON physical lines 4-13
      - Ethernet-type LAN 15-60
      - frame-relay connections 16-13, 16-59, 16-61
      - gateway cross-network sessions 14-24
      - ISDN accounting 7-34
      - nonswitched telecommunication links 5-2, 5-3
      - overview 24-16
      - SDLC subarea links 12-7
      - session accounting 24-15
    - NPM (NetView Performance Monitor) (*continued*)
      - performance data collection (*continued*)
        - Token-Ring connections 6-11, 6-23, 15-32, 16-65, 16-68
    - NPM publications X-37
    - NPSI publications X-36
    - NRF publications X-37
    - NRZI keyword 5-22
    - NTA (IBM Network Traffic Analyzer service) 11-15
    - NTO publications X-37
    - NTRI (NCP/Token-Ring interconnection)
      - See Token Ring
    - NTRISNAP keyword 23-3
    - NTuneMON
      - publications X-36
    - NTuneMON, monitoring and tuning NCP with 24-1
    - NTuneNCP
      - publication X-36
    - NUMADDR keyword 2-10, 14-9
    - NUMBER keyword 2-10, 10-3
    - NUMHSAS keyword 4-27, 14-4
    - NUMILU keyword 2-10, 5-34, 8-3, 8-9, 10-4
    - NUMROUTE keyword 2-11, 15-7
    - NUMSESS keyword 13-4, 14-10
    - NUMTYP1 keyword 2-10, 5-34, 10-4
    - NUMTYP2 keyword 2-10, 5-34, 6-22, 10-4
- ## O
- OBJLIB keyword
  - ODLC (outboard data link control) resources
    - fallback and switchback 3-8
    - Service Processor LAN 6-10, 6-34
  - OLT keyword 23-3
  - online tests 23-3
  - operating system 2-9
  - OPTIONS definition statement
    - keywords
      - DPU 2-19
      - FASTRUN 2-5, 21-10
      - NDNAME 2-2
      - NEWDEFN 2-2, 2-12, 2-16, 6-4, 16-9
      - NOTRDATA 22-2
      - NOTRGLOB 22-3
      - NOTRPARM 22-1
      - NOTRPROC 22-1
      - SAVEADDR 2-19
      - TMODEL 2-19
      - TRDATA 22-2
      - TRGLOB 22-3
      - TRPARM 22-1
      - TRPROC 22-1, 22-3
      - TRSNAP 22-2
      - TUSGTIER 2-19
      - TVERSION 2-19
      - USERGEN 13-8, 24-20

## Index

OPTIONS definition statement (*continued*)  
usage and position 1-8  
OPTIONS keyword 4-29  
ORDER keyword 24-4  
ORDHI keyword 13-7  
ORDINIT keyword 13-7  
ORDL2HI keyword 13-8  
ORDL2LO keyword 13-8  
ORDLO keyword 13-7  
out-of-sequence VR, deactivating 23-18  
overruns 21-18  
OWNER keyword 5-36, 6-25, 7-22, 16-51  
OWNERPL keyword 6-25  
frame relay 16-51  
ISDN 7-22  
Token Ring 6-25

## P

P2PDEST keyword 15-11, 15-49  
pacing 24-6  
PACING keyword 8-5, 24-6  
PACK, on the NEWDEFN keyword 2-2  
pad characters 21-19  
PAD keyword 20-6  
EP 21-19  
PADCNT keyword 19-1  
parallel channel transmission groups 12-26  
parallel data adapter 21-1  
parameter tracing 22-1  
parameter tracing, defining (EP) 21-10  
PARCHK keyword 18-2  
PARGEN keyword 18-2  
parity for TWX terminals 18-1  
partitioned emulation program (PEP)  
channel adapters 4-3  
using 20-1  
PASSLIM keyword 6-13, 12-5, 12-33, 24-9  
PATH definition statement  
keywords  
DESTSA 11-4, 12-18, 12-27, 14-16  
ER0-ER15 7-15, 11-4, 12-18, 12-27, 14-16  
VR0-VR7 11-11, 14-16  
VRPWS00-VRPWS72 11-11, 14-17  
usage and position 1-12, 1-23  
path information unit (PIU) 24-9  
PATHEXT keyword 11-13  
PAUSE keyword 5-39, 12-5, 24-11  
PCCU definition statement 1-9  
PECHAR keyword 18-1  
PEP (partitioned emulation program)  
channel adapters 4-3  
using 20-1  
performance  
data flow control 24-3  
data transfer 24-6  
performance (*continued*)  
EP 21-21  
initial inhibition of NCP functions 24-12  
internet route definitions 15-59  
keywords 7-33, 16-74  
MTA terminals 24-20  
network performance analyzer 24-16  
pacing for SDLC devices 24-6  
service order table (SOT) 24-4  
session accounting 14-25, 24-15  
timeout values 24-4  
timing 24-10  
transmission interrupts 24-14  
tuning 7-33, 16-74  
performance data collection  
basic 24-16  
by transmission priority 24-18  
peripheral device addresses, defining to VTAM 6-25,  
7-22, 16-51  
peripheral links  
BAN (Boundary Access Node) 16-45  
BNN (Boundary Network Node) 16-45  
frame-relay 16-45  
ISDN 7-18  
Token-Ring 6-20  
peripheral node, type 2.1  
See low-entry networking  
permanent virtual circuit (PVC), frame-relay 16-2, 16-6  
PHYPORT keyword 6-22, 6-30, 6-31  
physical connections  
ESCON 4-13  
Ethernet-type LAN 15-25  
frame relay 16-8  
ISDN 7-5  
Token Ring, peripheral 6-6  
Token Ring, subarea 6-28  
physical line group 21-6  
physical lines  
defining nonswitched frame-relay 16-8  
defining switched frame-relay 16-18  
physical unit  
link station 12-7  
logical groups associated with 6-22, 6-31  
peripheral channel link 4-4  
SDLC device 5-33, 5-35  
subarea channel link 4-2  
type 2.1  
peripheral channel links 4-4  
peripheral node support 8-1  
PHYSRSC keyword 4-15, 6-22, 6-25, 6-31, 7-11, 7-15,  
7-19, 15-23, 16-31, 16-48, 16-67  
PIU (path information unit) 24-9  
PIUCHECK keyword 16-36, 24-9  
ISDN 7-17  
SDLC subarea links 12-8  
Token Ring 6-32



- point-to-point line control 21-19
- point-to-point subarea link
  - configuring 12-8
  - defining 12-3
  - description 12-2
  - redefining 12-10
- POLIMIT keyword 5-40
- POLL keyword 5-41, 17-7
- POLLED keyword 5-40
- polling
  - character 5-40, 5-41, 17-7
  - IBM 3174 group poll 5-42
  - specifications 5-37
- POLLTO keyword 24-12
- PORT keyword 23-11
- PORTADD keyword 6-11, 7-7, 15-32, 15-41, 16-12
- position in NCP generation definition
  - ADD 1-25
  - BHSET 1-25
  - BUILD 1-9
  - CLUSTER 1-18
  - COMP 1-20
  - DATETIME 1-24
  - DELETE 1-26
  - DIALSET 1-14
  - EDIT 1-24
  - ENDAUTO 1-22
  - ENDBH 1-25
  - GENEND 1-25
  - GROUP 1-15
  - GWNAU 1-10, 1-23
  - HOST 1-10
  - IDLIST 1-11
  - IPHOST 1-21
  - IPLOCAL 1-22
  - IPROUTE 1-22
  - LINE 1-17
  - LU 1-21
  - LUDRPOOL 1-11
  - LUPOOL 1-11
  - MTALCST 1-14
  - MTALIST 1-14
  - MTAPOLL 1-14
  - MTATABL 1-14
  - NCPNAU 1-9
  - NETWORK 1-23
  - OPTIONS 1-9
  - PATH 1-12, 1-24
  - PCCU 1-9
  - PU 1-20
  - PUDRPOOL 1-12
  - REMOVCTL 1-25
  - SDLCST 1-12
  - SERVICE 1-17
  - STARTBH 1-24
  - SWMMT 1-15
- position in NCP generation definition (*continued*)
  - SYSCNTRL 1-9
  - TERMINAL 1-19
  - UBHR 1-24
- power-off feature 12-28
- predefining
  - addresses 14-9
  - HSCBs (half-session control blocks) 14-10
  - SDLC subarea links 12-2
- primary and secondary states 12-2
- primary rate interface 7-3
- printing of data, defining (EP) 21-10
- priority
  - FHSPs and FRTEs
    - COMRATE keyword 6-12, 7-17, 7-20, 15-33, 16-33, 16-49, 16-59, 16-66, 16-68
    - DATABLK keyword 6-10, 15-32, 15-46, 16-11, 16-64
  - protocols 15-46
  - resources 15-46
- procedure tracing 22-1
- procedure tracing, defining (EP) 21-9
- PRODID keyword 5-8
- program generation characteristics
  - data sets 2-6
  - defining 21-8
  - matching VTAM and NCP generation 2-6
  - naming load modules 2-8
  - operating system 2-9
  - operational 21-8
  - physical 21-8
  - program type 2-5
  - table assembly statements 2-8
  - verifying a generation definition 2-5
  - version number 2-9
- program type 2-5
- programmed resources 13-3
- PROMPT keyword 18-3
- prompting sequence for TWX terminals 18-1
- PROTOCOL keyword 15-11, 15-27, 15-35, 15-43, 15-49
- protocols
  - relative priority 15-46
- PRTGEN keyword 2-8
- PT1 keyword 9-4
- PT2 keyword 9-4
- PT2EXEC keyword 9-3
- PT3 keyword 9-4
- PT3EXEC keyword 9-6
- PU
  - See physical unit
- PU definition statement
  - keywords
    - ADDR 5-33, 6-12, 12-7, 15-33, 15-41, 16-59, 16-65
    - ANS 7-7, 7-12, 15-26, 15-33, 15-41, 16-49, 16-65, 16-68, 25-3

## Index

### PU definition statement (*continued*)

#### keywords (*continued*)

ARPTAB 15-26, 15-33, 15-46  
AVGPB 5-38  
BLOCK 7-16, 16-32, 24-7  
BNNSUP 5-33  
BRKCON 12-14  
CASDL 4-16, 15-23  
COMRATE 6-12, 15-33, 15-46, 16-32, 16-49,  
16-59, 16-65, 16-66, 16-68  
DATMODE 24-8  
DELAY 4-16, 15-23  
DYNWIND 16-15, 16-35  
ERRORT 7-8, 16-16  
GP3174 5-42  
HPQLIM 8-20  
INTFACE 15-41  
IRETRY 12-33, 25-5  
ISDNCFG 7-8  
ISDNDSCT 7-8  
LANTYPE 15-26  
LLERP 7-9, 8-21  
LMI 7-8, 16-16, 16-69  
LMODADR 23-16  
LPDA 23-4  
MAXBFRU 4-3, 4-6, 4-16, 15-21, 15-23  
MAXDATA 6-32, 6-42, 12-7, 12-26, 16-36, 24-8  
MAXLU 10-4  
MAXOUT 6-43, 16-60, 24-8  
MODULO 5-4, 5-42, 8-3, 12-7  
NETID 6-32, 7-17, 8-3, 8-12, 12-14, 14-6, 16-36  
NETWORK 6-13, 15-34, 15-42, 16-66  
NEXT 2-13  
NPACOLL 6-23, 12-7, 15-42, 16-18, 24-18,  
24-19  
NPATP 24-19  
PASSLIM 6-13, 12-33, 24-9  
PIUCHECK 16-36, 24-9  
PUCB 13-3  
PUDR 10-3, 12-33  
PUFVT 13-3  
PUNTFY 13-4  
PUTYPE 4-3, 4-6, 4-13, 4-17, 5-33, 5-35, 5-42,  
7-9, 7-12, 7-15, 7-21, 8-4, 12-8, 12-18, 12-27,  
12-33, 15-21, 15-23, 15-27, 15-34, 15-42, 15-48,  
16-50  
RETRIES 25-5  
ROLE 12-33  
SEGMENT 23-16  
SPOLL 7-9, 16-18, 16-69  
SRT 16-18, 16-69, 23-4, 25-5  
SSAP 6-31  
TGCONF 6-27, 6-32, 12-16, 16-66  
TGN 5-35, 10-4, 12-8, 12-19, 12-27  
TIMEOUT 4-17, 15-23  
TIMERS 7-9, 16-18, 16-70  
TRANSFR 4-17, 15-24

### PU definition statement (*continued*)

#### keywords (*continued*)

XID 8-4, 12-33, 24-10  
XMONLNK 5-16, 5-17, 7-9, 7-12, 16-18, 16-61,  
16-66, 16-70  
usage and position 1-20  
PU keyword of VTAM 5-33  
publications X-35  
3745 X-37  
3746 X-38  
MVS/ESA X-38  
NetView X-36  
NPM X-37  
NPSI X-36  
NRF X-37  
NTO X-37  
related X-37  
SecureWay X-36  
SNA X-36, X-38  
TCAM X-38  
VTAM X-36  
PUCB keyword 13-3  
PUDR keyword 4-16, 10-3, 12-33  
PUDRPOOL definition statement  
keywords  
FRSEDRPU 10-6, 16-59  
NUMBER 2-10, 10-3  
usage and position 1-12  
PUFVT keyword 13-3  
PUNAME keyword 2-8  
PUNTFY keyword 13-4  
PUTYPE keyword 4-3, 4-6, 4-13, 4-17, 5-33, 5-35,  
5-42, 7-9, 7-12, 7-15, 7-21, 8-4, 12-8, 12-14, 12-18,  
12-27, 12-33, 15-21, 15-23, 15-27, 15-34, 15-42,  
15-48, 16-50  
PVC (permanent virtual circuit), frame-relay 16-2, 16-6  
segments 16-15  
PWROFF keyword 12-28

## Q

QLIMIT keyword 5-5  
QLOAD keyword 5-5  
QSZALERT keyword 23-19  
QUIET keyword 20-8  
EP 21-21  
QUIETCT keyword 20-7  
EP 21-20

## R

RCVBUFC keyword 6-11, 6-41, 12-26, 15-32, 16-65,  
16-68  
RCVCHAR keyword 20-7  
EP 21-20

- redefinable lines
    - defining 5-19
    - not-valid keyword 2-13, 2-16, 24-17
  - REDIAL keyword 5-6, 5-9
  - relative line number 21-18
  - relative priority
    - protocols 15-46
    - resources 15-46
  - REMLU keyword 15-10
  - remote controller, loading and activating NCP in
    - over frame-relay lines 16-73
    - over ISDN lines 7-32
    - over SDLC and X.21 lines 12-29
    - over Token-Ring lines 6-48
  - remote loading 16-73
  - Remote Multiplexer 21-1
  - REMOTTO keyword 6-45
  - REMOVCTL definition statement
    - description 9-4
    - usage and position 1-25
  - reply timer, Token-Ring (T1) 6-44
  - REPLYTO keyword 24-4
    - EP 21-21
  - RESERVE keyword 5-5
  - resources
    - defining to EPSA 21-3
    - relative priority 15-46
  - response mode, defining (EP) 21-19
  - RESSCB keyword 8-4
  - RETRIES keyword 6-23, 6-31, 7-14, 7-16, 7-20, 12-5, 12-32, 16-30, 16-32, 16-48, 16-68, 17-6, 25-4, 25-5
  - RETRYTO keyword 5-6
  - REUSE, on the NEWDEFN keyword 2-3
  - reverse channel feature 21-1
  - RGENLEVL keyword 2-6
  - RING keyword 5-9, 23-16
    - EP 21-16
  - ring-indicator interface 21-16
  - RIP (Routing Information Protocol) 15-11, 15-27, 15-35, 15-43, 15-49, 15-53
    - versions supported 15-53
  - RIP-2 15-5
  - RIP-2 protocol 15-53
  - RNRLIMT keyword 5-2, 5-38, 6-23, 12-6
  - ROLE keyword 12-33
  - route
    - assigning 11-11, 14-17
    - cross-network paths 14-15
    - destination subarea address 11-4, 14-16
    - explicit 11-1, 11-4, 14-16
    - overview 11-1
    - tables 1-22, 15-7
    - virtual 11-10
    - virtual route pacing window 11-11, 14-16
  - Route Table Generator (RTG) 11-15
  - router definition statements
    - frame relay 1-6
    - internet 1-6
  - router interfaces 15-2
  - router-to-router connection 15-3, 15-39
  - Routing Information Protocol (RIP) 15-11, 15-27, 15-35, 15-43, 15-49
  - routing, internet
    - datagrams to a subnetwork 15-11
    - dynamic 15-7
    - interfaces 15-2
  - RTG (Route Table Generator) 11-15
- ## S
- SALIMIT keyword 4-26, 14-5
  - sample system generation definitions A-7
  - SAVEADDR keyword 2-19
  - scanner interface trace 23-2
    - BSC and SS devices 21-13
    - EP 21-13
    - part of DYNADMP 21-13
  - SDLC device
    - nonswitched 5-26, 5-33
    - pacing 24-6
    - switched 5-30
    - VTAM 5-36
  - SDLC links
    - 3746 Model 900 links 3-6, 5-1, 5-21
    - backup session 25-6
    - dynamic reconfiguration 10-5
    - monitor mode 5-12
    - multipoint 12-2
    - point-to-point 12-2
    - shared port identification 5-11
    - spare lines 5-19
    - subarea
      - defining 12-3
      - multipoint 12-2
      - point-to-point 12-2
      - switched 12-13
  - SDLCST definition statement
    - keywords
      - GROUP 7-14, 12-4, 16-30
      - MAXOUT 12-4
      - MODE 7-14, 12-5, 16-30, 16-31
      - PASSLIM 12-5
      - PAUSE 12-5
      - RETRIES 7-14, 7-20, 12-5, 16-30
      - SERVLIM 12-5
      - TADDR 12-6
    - usage and position 1-12
  - SDLCST keyword 7-16, 12-7, 16-32
  - SECNET keyword of VTAM 5-33
  - SECURE keyword 5-7

## Index

- SecureWay publications X-36
- SEGMENT keyword 23-16
- segment size, MLTG 12-23
- sequence of definition statements 1-8
- serial automatic calling 5-7
- SERVICE definition statement
  - keywords
    - MAXLIST 10-3, 12-32
    - ORDER 24-4
  - usage and position 1-17
- service order table 24-4
- service order table scans 12-5
- Service Processor LAN, ODLG 6-10, 6-34
- SERVLIM keyword 12-5, 24-5
- SERVPRI keyword 24-12
- SESSACC keyword 2-11, 24-15
- session accounting 14-25, 24-15, 24-19
- SESSION keyword 5-37
- session pacing 24-6
- sessions
  - address control blocks 14-8
  - cross-network 14-8
  - half-session control blocks 14-10
  - maximum number 5-37
  - SSCP (system services control point) 4-27
- SESSLIM keyword 14-11
- SESSREQ keyword 5-41
- shared port identification 5-11
- shared resources, ESCON 3-7
- shared resources, Token-Ring 3-7
- sign-on procedures for MTA terminals 17-1
- single link transmission groups 12-16
- six-bit transmission code 21-1
- SLODOWN keyword 24-3
- slowdowns 21-18
- SMMF (SSCP monitor mode function)
  - description 5-12
  - ESCON links 5-17
  - nonswitched SDLC peripheral devices 5-15
  - nonswitched SDLC subarea links 5-12
  - subarea channel links 5-16
  - switched SDLC subarea links 5-13
- SNA
  - network interconnection 14-3
  - subnetworks 15-6
  - transport logical unit 15-8
- SNA publications X-36, X-38
- snap trace 23-2
- SNETMASK keyword 15-11, 15-27, 15-35, 15-43, 15-49, 15-56
- SNI non-native network definition statements 1-7
- Society for Worldwide Interbank Financial Telecommunication (SWIFT) 21-17, 21-20
- softcopy documentation xxxiv
- softcopy library, NCP, SSP, and EP xxxv
- spare lines
  - defining 5-19
  - not-valid keyword 2-13, 2-16, 24-17
- SPDSEL keyword 5-23
- SPEED keyword 4-13, 4-16, 5-3, 5-7, 5-23, 7-7, 7-12, 15-23, 15-41, 16-13, 17-6
  - EP 21-15
- SROLL keyword 7-9, 16-18, 16-69
- SRCHI keyword 13-6
- SRCLO keyword 13-6
- SRETRY keyword 12-32
- SRT keyword 4-13, 4-17, 16-18, 16-69, 23-4, 25-5
- SS devices
- SS line control 21-12
- SSAP keyword 6-31
- SSCP (system services control point)
  - concurrent sessions 4-27
  - gateway and interconnected networks 14-1
- SSCP monitor mode function (SMMF)
  - description 5-12
  - ESCON links 5-17
  - nonswitched SDLC peripheral devices 5-15
  - nonswitched SDLC subarea links 5-12
  - subarea channel links 5-16
  - switched SDLC subarea links 5-13
- stand-alone definition statement 1-15, 12-8, 17-6
- standalone Emulation Program (EPSA) 21-1—21-22
- start-stop devices
  - MTA terminals 17-1
  - operating in emulation mode 20-1
  - TWX terminals 18-1
  - WTTY terminals 19-1
- STARTBH definition statement
  - keyword 9-2
  - usage and position 1-24
- station, logical-connection 5-29
- stations, clustered 21-14
- subarea
  - address of NCP 2-8, 4-26
  - casual connection 8-1, 12-29
  - channel-link activation 5-16, 25-3
  - communicating with NCP 4-27
  - defining a destination subarea address 12-18
  - destination subarea address 11-4, 14-16
  - frame-relay subarea links 16-27, 16-77
  - ISDN subarea links 7-13
  - link stations 12-1
  - links 12-1
  - maximum number in network 4-26
  - switched 12-13
  - Token-Ring logical connections 5-13, 6-29, 12-13
- SUBAREA keyword 2-8, 4-26, 14-5
- subchannel address (EP)
  - highest 21-11
  - lowest 21-11

- subchannel, emulation 21-16
  - subnetwork
    - dividing internet networks into 15-28, 15-36
    - mask 15-6
    - routing datagrams to 15-28, 15-36
  - SUPPORTS keyword 16-61
  - summary of release changes xxxii
  - SUPP, on the NEWDEFN keyword 2-2
  - SWIFT (Society for Worldwide Interbank Financial Telecommunication) 21-17, 21-20
  - switchback 3-2, 3-5
  - switched frame-relay physical line
    - defining 16-18
    - examples 16-93
    - sample definitions 16-93
  - switched lines
    - EP 21-15, 21-19
  - switched network backup 5-25
  - switched subarea 5-13, 12-13
  - switched telecommunication links
    - defining 5-4
    - devices 5-30
    - emulation mode 20-4
    - modems 23-15
    - shared port identification 5-11
    - TWX terminals 18-2
    - V.25 bis 5-7
  - SWMMT definition statement
    - keywords
      - IDNUM 5-13, 7-33
      - MAXDATA 5-13
      - MAXOUT 5-13, 7-33
      - NETID 5-13, 7-33
    - usage and position 1-15
  - SWMMTID keyword 5-14, 7-33
  - synchronous data adapter type 1 21-1
  - SYSCNTRL definition statement
    - keyword 4-29
    - usage and position 1-9
  - system definition statement 21-3
  - system definition statements 1-5
  - system services control point (SSCP)
    - concurrent sessions 4-27
    - gateway and interconnected networks 14-1
- T**
- T2TIMER keyword 6-42, 6-45, 7-16, 7-20, 16-32, 16-36
  - table assembly statements 2-8
  - TADDR keyword 12-6, 12-7, 12-32
    - EP 21-17
  - TAILING keyword 12-32, 23-7, 23-11
  - TCAM publications X-38
  - TCP/IP (Transmission Control Protocol/Internet Protocol) 15-1
  - TCP/IP (Transmission Control Protocol/Internet Protocol) (*continued*)
    - publications X-38
  - telecommunication links
    - devices 5-26, 5-33
    - emulation mode 20-3
    - MTA terminals 17-1, 17-7
    - nonswitched links 5-1
    - SSCP monitor mode 5-12
    - switched
      - defining 5-4, 23-15
      - devices 5-30
      - emulation mode 20-3
      - modems 23-15
      - shared port identification 5-11
    - V.25 bis 5-7
  - teletypewriter exchange service (TWX) terminals
    - character transmission 18-1
    - defining 18-1
    - keyboard lock function 18-1
    - MTA terminals 18-4
    - parity 18-1
    - prompting sequence 18-1
  - TERM keyword 5-29, 20-5
    - EP 21-16
  - terminal adapter 7-3
  - TERMINAL definition statement
    - keywords
      - ADDR 5-41
      - ATTN 5-28
      - BFRDLAY 5-46
      - BHEXEC 9-6
      - BHSET 9-6
      - CONV 5-28
      - CRDLAY 5-28
      - CRITSIT 25-3
      - CTERM 5-31
      - CUIDLEN 5-31, 18-4
      - DIALNO 5-31
      - DIALSET 5-31
      - ENDTRNS 5-45
      - FANOUT 5-28
      - FEATURE 5-28
      - IDSEQ 5-31, 18-4
      - INHIBIT 24-13
      - ITBMODE 5-44
      - LCST 17-6
      - LGRAPHS 5-28
      - LMODADR 23-16
      - NEXT 2-13
      - NPACOLL 24-17
      - POLL 5-41
      - PT3EXEC 9-6
      - SEGMENT 23-16
      - SESSREQ 5-41
      - SRT 25-5
      - TERM 5-29

## Index

- TERMINAL definition statement (*continued*)
  - keywords (*continued*)
    - VPRINT 5-29
    - XTWXID 18-2
  - usage and position 1-18
- terminating equipment support (TESP), frame relay
  - definition of term 16-5
  - for peripheral links 16-49
  - for subarea links 16-32, 16-36
- terminology overview xxviii
- TEST keyword 21-14
- TEXTTO keyword 24-4
  - EP 21-22
- TG characteristics 5-3, 5-7, 8-21
- TGBXTRA keyword 11-13
- TGCONF keyword 6-27, 6-32, 12-16, 16-66
- TGN keyword 4-17, 6-32, 12-8, 12-19, 12-27, 16-36
- TIC (Token-Ring interface coupler)
  - backup TICs 6-15
  - connection balancing, duplicate TICs 6-16
  - TIC internal trace 23-2
  - TIC swap 6-15
  - type 1 TIC 6-7, 6-15, 6-35, 15-31, 16-64
  - type 2 TIC 6-7, 6-15, 6-35, 15-31, 16-64
  - type 3 TIC 6-1, 6-7, 6-15, 6-35, 15-31, 15-40, 16-64
- time and date routine 9-2
- timeout
  - disable 21-15
  - emulation mode 20-7
  - EP 21-15, 21-21
  - values 24-4
- TIMEOUT keyword 4-3, 4-6, 4-17, 15-20, 15-23
- TIMER keyword 9-3
- timers for logical connections
  - T1 (Token-Ring reply timer) 6-44, 7-16, 7-20
  - T2 (Token-Ring acknowledgment timer) 6-45
  - TI (inactivity timer)
    - frame-relay 16-13
    - Token-Ring 6-46
- TIMERS keyword 7-9, 16-18, 16-70
- timing 24-10
- TITIMER keyword 6-46, 7-7, 16-13
- TMODEL keyword 2-19
- TMRTICK keyword 13-6
- TO keyword 10-1
- Token Ring
  - 3746 Model 900 connections 6-1
  - acknowledgment timer (T2) 6-45
  - adapter
    - type 1 6-7, 6-15, 6-35, 15-31, 16-64
    - type 2 6-7, 6-15, 6-35, 15-31, 16-64
    - type 3 6-1, 6-7, 6-15, 6-35, 15-31, 16-64
  - automatic value selection 6-4, 6-5
  - backup TICs 6-15
  - connection balancing, duplicate TICs 6-16
  - defining logical connections
    - acknowledgment timer (T2) 6-45
  - defining logical connections (*continued*)
    - definition 6-20, 6-21
    - description 6-1
    - error recovery and retries 6-47
    - inactivity timer (TI) 6-44, 6-46
    - peripheral 6-33
    - reply timer (T1) 6-44
    - subarea 6-29, 6-33
    - timers for logical connections 6-44
    - unassigned logical connections 6-24
  - defining physical connections 6-6
  - defining resources 6-3
  - duplicate TIC addresses 6-16
  - general Token-Ring definitions 6-6
  - generation definition 6-4
  - inactivity timer (TI) 6-46
  - local connections 6-2
  - logical units 6-11, 6-22
  - LUDRPOOL definition statement required 1-11
  - NDF additions
    - defining NTRI 6-1, 6-27, 12-15
    - definition file 2-1
    - verifying generation definition 2-5, 21-11
  - network 6-1, 6-27
  - NEWDEFN file 2-1
  - NTRI 6-1
    - attachments for frame relay 16-63
  - overview 6-1, 6-27, 12-15
  - performance characteristics
    - data transfer characteristics 6-39
    - frame size 6-40
    - frame transmission window size 6-42
    - MLTG segment size 12-23
    - ring speed 6-39
  - peripheral connections 6-2
  - physical connection definition 6-1, 6-6, 6-28
  - remote connections 6-2
  - reply timer (T1) 6-44
  - resources
    - peripheral 6-1
    - subarea 6-27, 12-15
  - snap trace 23-2
  - subarea links
    - defining logical connections 6-29
    - overview 6-2, 6-27, 6-29, 12-15
  - subarea resources coding example 6-28
  - TIC
    - backup TIC 6-15
    - internal trace 23-3
    - TIC swap 6-15
  - topology 5-3, 5-7, 8-21
- TRACE keyword 23-2
- traces
  - address 23-2
  - APPN HPR resources 23-2

- traces (*continued*)
    - branch 23-2
    - channel adapter 23-1
    - channel adapter IOH 23-1
    - data 22-1
    - dynamic dump 21-13
    - EP 21-13
    - frame relay 23-2
    - global 22-2
    - internet resources 23-2
    - line 23-2
    - parameter 22-1
    - procedure 22-1
    - scanner interface 23-2
    - snap 23-3
    - TIC internal 23-2
  - tracing of data, defining (EP) 21-10
  - tracing of parameters, defining (EP) 21-10
  - tracing of procedures, defining (EP) 21-9
  - trademarks xxv
  - TRANSBUF keyword 16-13
  - TRANSFER keyword 4-3, 4-6, 4-17, 8-3, 12-7, 12-26, 15-20, 15-24, 17-6, 24-2, 24-7
  - transmission code
    - BSC 21-19
    - six-bit 21-1
  - Transmission Control Protocol/Internet Protocol (TCP/IP) 15-1
    - publications X-38
  - transmission control unit 21-14
  - transmission groups
    - defining 12-15
    - explicit routes 11-1
    - mixed-media MLTG (MMMLTG) 12-16
    - MLTG (multilink transmission group) 12-16
    - number for MLTG 12-19
    - parallel channel 12-26
    - single link 12-26
    - used in routing 11-1
  - transmission interrupts 24-14
  - transmission priority 6-10, 6-12, 7-17, 7-20, 15-32, 15-33, 15-46, 16-11, 16-33, 16-49, 16-59, 16-64, 16-66, 16-68, 24-18
  - TRCPIU keyword 24-7
  - TRDATA keyword 22-2
    - EP 21-10
  - TRGLOB keyword 22-3
    - EP 21-10
  - tributary station, BSC 21-17
  - TRPARAM keyword 22-1
    - EP 21-10
  - TRPROC keyword 22-1, 22-3
    - EP 21-9
  - TRSNAP keyword 22-2
    - EP 21-10
  - TRSPEED keyword 6-12, 6-39, 15-33, 15-41
  - TTDCNT keyword 24-11
  - tuning
    - NCP using NTuneMON 24-1
    - performance-related keywords 16-75
  - TUSGTIER keyword 2-19
  - TVERSION keyword 2-9, 2-19
  - two-processor switch, programmable 21-1
  - TWX (teletypewriter exchange service) terminals
    - character transmission 18-1
    - defining 18-1
    - EP 21-20
    - keyboard lock function 18-1
    - MTA terminals 18-4
    - parity 18-1
    - prompting sequence 18-1
  - TWXID keyword 18-3
  - type 2.1 peripheral node
    - addresses for peripheral PLUs 8-8
    - building independent logical unit control block pools 8-10
    - data transfer limit 8-3
    - delaying initial transmission 8-3
    - independent logical units 8-4
    - independent logical units for dynamic reconfiguration 8-3
    - multiple and parallel session diagram 8-7
    - multiple and parallel sessions 8-7
    - network names table entries 2-7, 8-12, 14-3
    - overview 8-1
    - physical unit type 8-4
    - PIUs 8-3
    - point-to-point subarea links 12-8
    - receiving and responding to XIDs 8-4
    - reserved boundary session control blocks 8-4
    - specifying boundary session control blocks 8-8
    - specifying LU-LU sessions 8-9
  - type 3 (3746 Model 900) channel adapter 4-13
  - type 3 TIC 15-32
    - internet traffic 15-32
  - type 7 channel adapter (buffer chaining) 4-7
  - TYPE keyword 5-2, 5-3, 13-4
  - TYPGEN keyword 2-8
  - TYP SYS keyword 2-9
    - EP 21-8
- ## U
- UACB keyword 13-3
  - UACCTNG keyword 13-6, 24-20
  - UBHR definition statement
    - keywords
      - ACCESS 9-3
      - COMMAND 9-3
      - ENTRY 9-3
      - NAME 9-3
      - PT2EXEC 9-3

## Index

- UBHR definition statement (*continued*)
    - usage and position 1-24
  - UCCB keyword 13-5
  - UCHAN keyword 13-5
  - UCW 21-11
  - UDPPORT keyword 15-8
  - UGLOBAL keyword 13-6
  - unassigned logical line pools 7-22, 16-50
  - unassigned logical line pools, allocating 6-25
  - UNIQUE keyword 6-32
  - unit control words 21-11
  - UNIT keyword
  - unit-exception status 21-19
  - UNITXC keyword 20-6, 20-7
    - EP 21-19
  - usage of definition statements 1-8
  - usage tier, determining 2-19
  - usage tiers 3-2, 3-9
  - usage, definition statements
    - ADD 1-25
    - BHSET 1-25
    - BUILD 1-9
    - CLUSTER 1-18
    - COMP 1-19
    - DATETIME 1-24
    - DELETE 1-26
    - DIALSET 1-13
    - EDIT 1-24
    - ENDAUTO 1-22
    - ENDBH 1-25
    - GENEND 1-25
    - GROUP 1-15
    - GWNAU 1-10, 1-23
    - HOST 1-10
    - IDLIST 1-11
    - LINE 1-16
    - LU 1-21
    - LUDRPOOL 1-11
    - LUPOOL 1-11
    - MTALCST 1-14
    - MTALIST 1-14
    - MTAPOLL 1-14
    - MTATABL 1-14
    - NCPNAU 1-9
    - NETWORK 1-22
    - OPTIONS 1-8
    - PATH 1-12, 1-23
    - PCCU 1-9
    - PU 1-20
    - PUDRPOOL 1-12
    - REMOVCTL 1-25
    - SDLCST 1-12
    - SERVICE 1-17, 1-21
    - STARTBH 1-24
    - SWMMT 1-15
    - SYSCNTRL 1-9
    - usage, definition statements (*continued*)
      - TERMINAL 1-18
      - UBHR 1-24
    - USE keyword 20-3
    - user channel-handling code
      - accounting exit routine 14-24
      - accounting notification routine 24-19
      - channel control code 13-4
      - routines for block handlers 9-3
    - user line control 13-1
    - user-written generation definition 6-4
    - USERGEN keyword 13-8, 24-20
    - USERID keyword 13-2
    - USGTIER keyword 3-2
    - USSTAB keyword of VTAM 5-33
    - UT1 keyword
    - UT2 keyword
    - UT3 keyword
- ## V
- V.25 bis, defining 5-7
  - V25BIS keyword 5-9
  - V7R8, term xxx
  - variable subnetting 10-7
  - VERSION keyword 2-9, 2-19
    - EP 21-9
  - VIROWNER keyword 13-8
  - VIRTUAL keyword 13-3
  - virtual route
    - assigning 11-11, 14-17
    - defining 4-28, 11-10
    - interconnected network 14-15
    - pacing window 11-11, 14-16
    - time limits, blocked alerts 23-18
  - virtual route deactivation, out-of-sequence 23-18
  - VPACING keyword 8-5
  - VPACING keyword of VTAM 5-33
  - VPRINT keyword 5-29
  - VR deactivation, out-of-sequence 23-18
  - VR0–VR7 keywords 11-11, 14-17
  - VRPOOL keyword 4-28, 11-14
  - VRPWS00–VRPWS72 keywords 11-11, 14-16
  - VRTIMERn keyword 23-18
  - VSUBNETS keyword 15-55
  - VTAM
    - activating NCP 4-29
    - BSC devices 5-33
    - cross-network paths 14-23
    - keywords
      - ASLENT 5-33, 5-36
      - ASLTAB 5-33, 5-36
      - COSTAB 14-24
      - DISCNT 5-33, 5-36
      - DLOGMOD 5-33, 5-36
      - ENCR 5-36
      - FEATUR2 5-33, 5-36



## VTAM (continued)

## keywords (continued)

INNPORT 5-36  
 ISTATUS 5-33, 5-36  
 LOGAPPL 5-33, 5-36  
 LOGTAB 5-33, 5-36  
 MDLENT 5-33, 5-36  
 MDLTAB 5-33, 5-36  
 MODETAB 5-33, 5-36  
 NEWPATH 11-14  
 OWNER 5-36  
 PU 5-33  
 SECNET 5-33  
 SPAN 5-36  
 SSCPFM 5-36  
 TERM 5-36  
 USSTAB 5-33, 5-36  
 VPACING 5-33, 5-36  
 SDLC devices 5-36  
 VTAM publications X-36  
 VTAMLST 8-2, 8-6, 8-9

**W**

WACKCNT keyword 24-11  
 WAKDLAY keyword 24-11  
 WTTY terminals  
   character transmission 19-1  
   defining 19-1  
   emulation mode 20-4  
   EP 21-21  
 WTTYEOB keyword 19-1  
 WTTYEOT keyword 19-1

**X**

X.21 resources 5-1, 5-3, 5-6  
 X.21 resources and 3746 Model 900 SDLC lines 5-21  
 X.25 resources 2-1  
 X21NTWK keyword 5-6  
 X21SW keyword 5-6  
 XBREAK keyword 24-14  
 XID keyword 8-4, 12-33, 24-10  
 XIO keyword 13-2  
 XMITDLY keyword 5-6, 8-3  
 XMONLNK keyword 5-16, 5-17, 7-9, 7-12, 16-18,  
   16-61, 16-66, 16-70  
 XRF 25-6  
 XTWXID keyword 18-2



---

# Tell Us What You Think!

**Network Control Program  
System Support Programs  
Emulation Program  
Resource Definition Guide  
Publication No. SC31-6223-08**

We hope you find this publication useful, readable, and technically accurate, but only you can tell us! Your comments and suggestions will help us improve our technical publications. Please take a few minutes to let us know what you think by completing this form. If you are in the USA, you can mail this form postage free or fax it to us at 1-800-253-3520. Elsewhere, your local IBM branch office or representative will forward your comments or you may mail them directly to us.

Overall, how satisfied are you with the information in this book?	Satisfied	Dissatisfied
	<input type="checkbox"/>	<input type="checkbox"/>

How satisfied are you that the information in this book is:	Satisfied	Dissatisfied
Accurate	<input type="checkbox"/>	<input type="checkbox"/>
Complete	<input type="checkbox"/>	<input type="checkbox"/>
Easy to find	<input type="checkbox"/>	<input type="checkbox"/>
Easy to understand	<input type="checkbox"/>	<input type="checkbox"/>
Well organized	<input type="checkbox"/>	<input type="checkbox"/>
Applicable to your task	<input type="checkbox"/>	<input type="checkbox"/>

Specific comments or problems:

---

---

---

Please tell us how we can improve this book:

---

---

---

Thank you for your comments. If you would like a reply, provide the necessary information below.

\_\_\_\_\_  
Name

\_\_\_\_\_  
Address

\_\_\_\_\_  
Company or Organization

\_\_\_\_\_

\_\_\_\_\_  
Phone No.

\_\_\_\_\_



Fold and Tape

Please do not staple

Fold and Tape



NO POSTAGE  
NECESSARY  
IF MAILED IN THE  
UNITED STATES

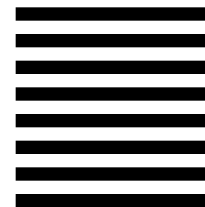

# BUSINESS REPLY MAIL

FIRST-CLASS MAIL PERMIT NO. 40 ARMONK, NEW YORK

POSTAGE WILL BE PAID BY ADDRESSEE

Design & Information Development  
Dept. CGF/Bldg. 656  
International Business Machines Corporation  
PO BOX 12195  
RESEARCH TRIANGLE PARK NC 27709-9990



Fold and Tape

Please do not staple

Fold and Tape





File Number: S370/4300/30XX  
Program Number: 5648-063  
5655-041  
5654-009  
5686-064  
5735-XXB



Printed in the United States of America  
on recycled paper containing 10%  
recovered post-consumer fiber.

SC31-6223-08

